

TEST BANK



THOMAS' Thirteenth Edition
CALCULUS

MULTIPLE CHOICE. Choose the one alternative that best completes the statement or answers the question.

Find the average rate of change of the function over the given interval.

1) $y = x^2 + 8x$, $[4, 9]$ 1) _____
A) $\frac{153}{5}$ B) $\frac{35}{3}$ C) 21 D) 17

2) $y = 7x^3 + 5x^2 + 2$, $[-5, 5]$ 2) _____
A) $\frac{501}{5}$ B) 350 C) $\frac{1002}{5}$ D) 175

3) $y = \sqrt{2x}$, $[2, 8]$ 3) _____
A) $-\frac{3}{10}$ B) 7 C) $\frac{1}{3}$ D) 2

4) $y = \frac{3}{x-2}$, $[4, 7]$ 4) _____
A) 2 B) 7 C) $\frac{1}{3}$ D) $-\frac{3}{10}$

5) $y = 4x^2$, $\left[0, \frac{7}{4}\right]$ 5) _____
A) 2 B) $\frac{1}{3}$ C) $-\frac{3}{10}$ D) 7

6) $y = -3x^2 - x$, $[5, 6]$ 6) _____
A) -2 B) -34 C) $\frac{1}{2}$ D) $-\frac{1}{6}$

7) $h(t) = \sin(5t)$, $\left[0, \frac{\pi}{10}\right]$ 7) _____
A) $\frac{10}{\pi}$ B) $-\frac{10}{\pi}$ C) $\frac{5}{\pi}$ D) $\frac{\pi}{10}$

8) $g(t) = 4 + \tan t$, $\left[-\frac{\pi}{4}, \frac{\pi}{4}\right]$ 8) _____
A) $-\frac{4}{\pi}$ B) $-\frac{3}{2}$ C) 0 D) $\frac{4}{\pi}$

Find the slope of the curve at the given point P and an equation of the tangent line at P.

9) $y = x^2 + 5x$, $P(4, 36)$ 9) _____
A) slope is $-\frac{4}{25}$; $y = -\frac{4x}{25} + \frac{8}{5}$ B) slope is -39; $y = -39x - 80$
C) slope is $\frac{1}{20}$; $y = \frac{x}{20} + \frac{1}{5}$ D) slope is 13; $y = 13x - 16$

10) $y = x^2 + 11x - 15$, $P(1, -3)$

A) slope is $-\frac{4}{25}$; $y = -\frac{4x}{25} + \frac{8}{5}$

C) slope is $\frac{1}{20}$; $y = \frac{x}{20} + \frac{1}{5}$

B) slope is -39 ; $y = -39x - 80$

D) slope is 13 ; $y = 13x - 16$

10) _____

11) $y = x^3 - 9x$, $P(1, -8)$

A) slope is -6 ; $y = -6x$

C) slope is -6 ; $y = -6x - 2$

B) slope is 3 ; $y = 3x - 7$

D) slope is 3 ; $y = 3x - 11$

11) _____

12) $y = x^3 - 2x^2 + 4$, $P(3, 13)$

A) slope is 1 ; $y = x - 32$

C) slope is 15 ; $y = 15x - 32$

B) slope is 15 ; $y = 15x + 13$

D) slope is 0 ; $y = -32$

12) _____

13) $y = 4 - x^3$, $(1, 3)$

A) slope is 0 ; $y = 6$

C) slope is 3 ; $y = 3x + 6$

B) slope is -1 ; $y = -x + 6$

D) slope is -3 ; $y = -3x + 6$

13) _____

Use the slopes of **UQ**, **UR**, **US**, and **UT** to estimate the rate of change of **y** at the specified value of **x**.

14) $x = 5$

14) _____

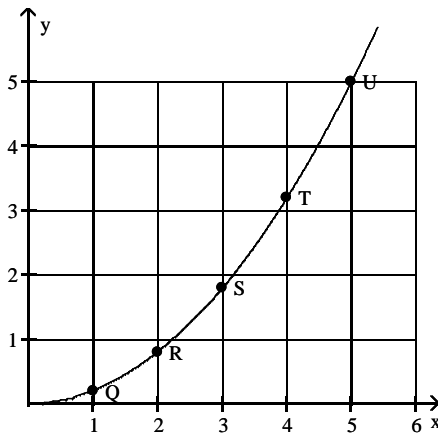

A) 0

B) 2

C) 5

D) 1

15) $x = 3$

15) _____

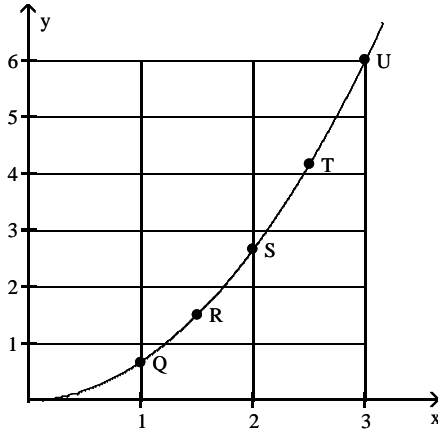

A) 4

B) 2

C) 6

D) 0

16) $x = 5$

16) _____

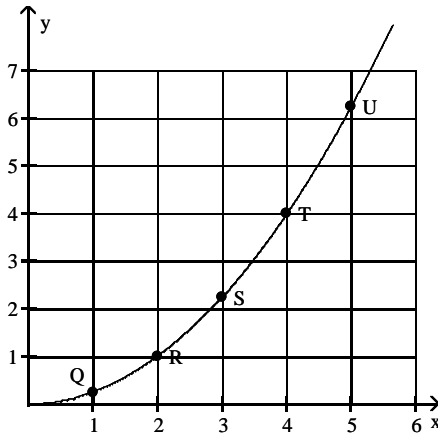

A) $\frac{5}{2}$

B) $\frac{5}{4}$

C) 0

D) $\frac{25}{4}$

17) $x = 2$

17) _____

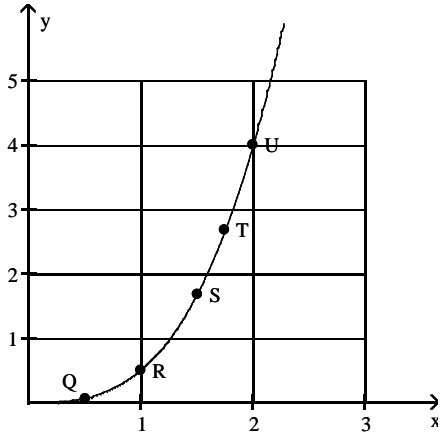

A) 0

B) 4

C) 3

D) 6

18) $x = 2.5$

18) _____

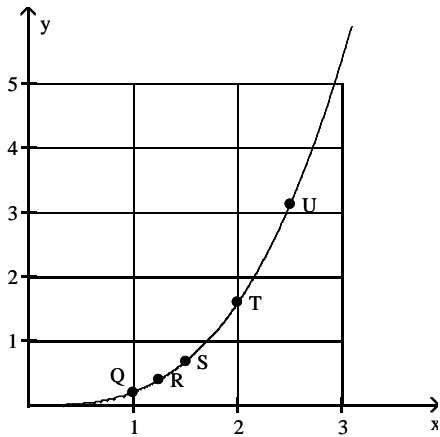

A) 0

B) 7.5

C) 1.25

D) 3.75

Use the table to estimate the rate of change of y at the specified value of x .

19) $x = 1$.

19) _____

| x | y |
|-----|------|
| 0 | 0 |
| 0.2 | 0.02 |
| 0.4 | 0.08 |
| 0.6 | 0.18 |
| 0.8 | 0.32 |
| 1.0 | 0.5 |
| 1.2 | 0.72 |
| 1.4 | 0.98 |

A) 0.5

B) 1.5

C) 1

D) 2

20) $x = 1$.

20) _____

| x | y |
|-----|------|
| 0 | 0 |
| 0.2 | 0.01 |
| 0.4 | 0.04 |
| 0.6 | 0.09 |
| 0.8 | 0.16 |
| 1.0 | 0.25 |
| 1.2 | 0.36 |
| 1.4 | 0.49 |

A) 2

B) 1.5

C) 0.5

D) 1

21) $x = 1$.

21) _____

| x | y |
|-----|------|
| 0 | 0 |
| 0.2 | 0.12 |
| 0.4 | 0.48 |
| 0.6 | 1.08 |
| 0.8 | 1.92 |
| 1.0 | 3 |
| 1.2 | 4.32 |
| 1.4 | 5.88 |

A) 4

B) 2

C) 6

D) 8

22) $x = 2$.

22) _____

| x | y |
|-----|----|
| 0 | 10 |
| 0.5 | 38 |
| 1.0 | 58 |
| 1.5 | 70 |
| 2.0 | 74 |
| 2.5 | 70 |
| 3.0 | 58 |
| 3.5 | 38 |
| 4.0 | 10 |

A) -8

B) 8

C) 0

D) 4

23) $x = 1$.

23) _____

| x | y |
|-------|----------|
| 0.900 | -0.05263 |
| 0.990 | -0.00503 |
| 0.999 | -0.0005 |
| 1.000 | 0.0000 |
| 1.001 | 0.0005 |
| 1.010 | 0.00498 |
| 1.100 | 0.04762 |

A) 1

B) 0.5

C) -0.5

D) 0

Solve the problem.

24) When exposed to ethylene gas, green bananas will ripen at an accelerated rate. The number of days for ripening becomes shorter for longer exposure times. Assume that the table below gives average ripening times of bananas for several different ethylene exposure times:

24) _____

| Exposure time (minutes) | Ripening Time (days) |
|-------------------------|----------------------|
| 10 | 4.2 |
| 15 | 3.5 |
| 20 | 2.6 |
| 25 | 2.1 |
| 30 | 1.1 |

Plot the data and then find a line approximating the data. With the aid of this line, find the limit of the average ripening time as the exposure time to ethylene approaches 0. Round your answer to the nearest tenth.

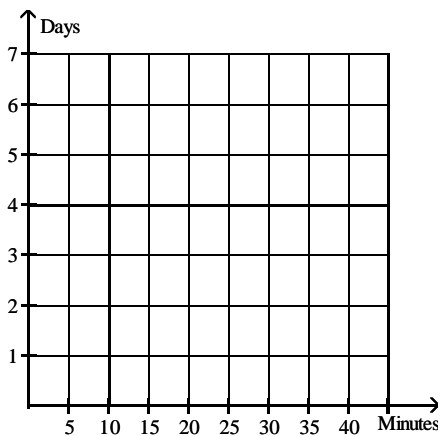

A)

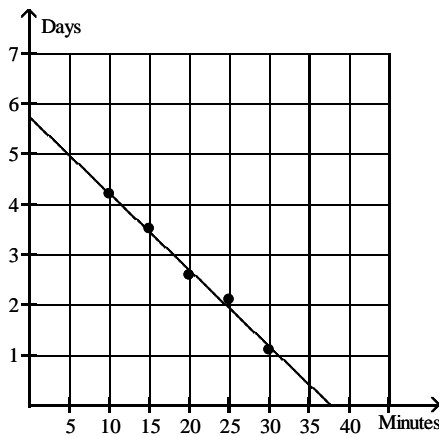

37.5 minutes

B)

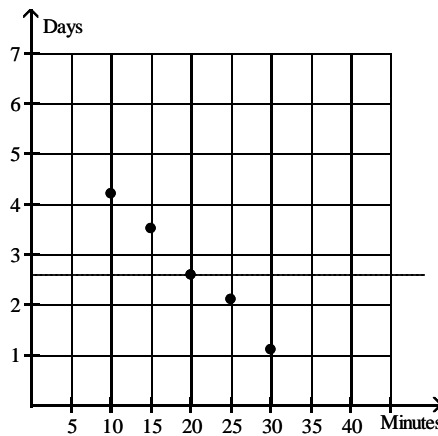

2.6 days

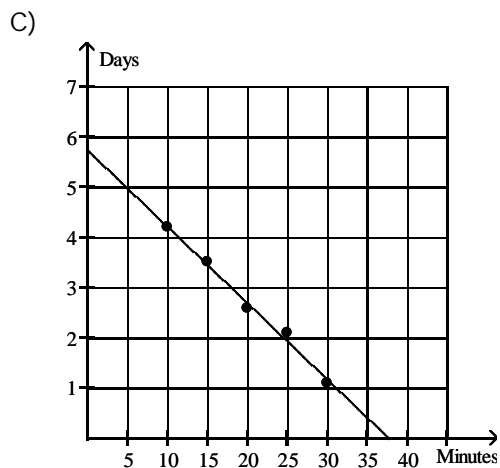

5.8 days

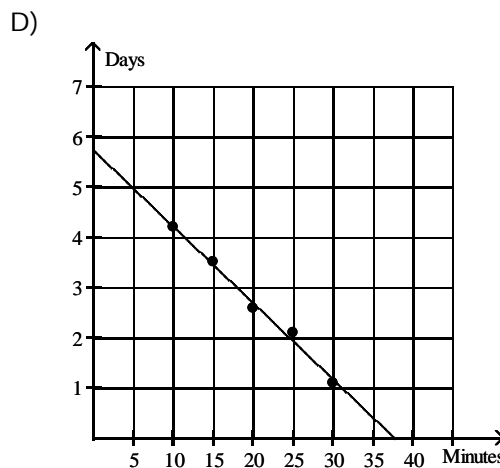

0.1 day

25) When exposed to ethylene gas, green bananas will ripen at an accelerated rate. The number of days for ripening becomes shorter for longer exposure times. Assume that the table below gives average ripening times of bananas for several different ethylene exposure times.

25) _____

| Exposure time (minutes) | Ripening Time (days) |
|----------------------------|-------------------------|
| 10 | 4.3 |
| 15 | 3.2 |
| 20 | 2.7 |
| 25 | 2.1 |
| 30 | 1.3 |

Plot the data and then find a line approximating the data. With the aid of this line, determine the rate of change of ripening time with respect to exposure time. Round your answer to two significant digits.

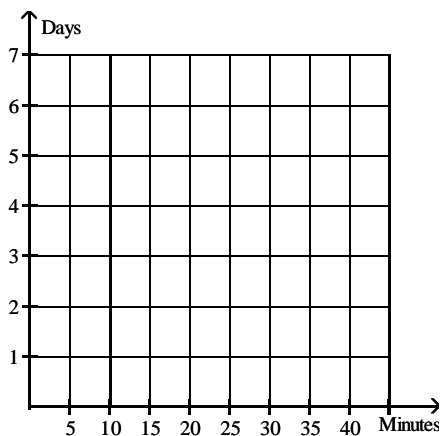

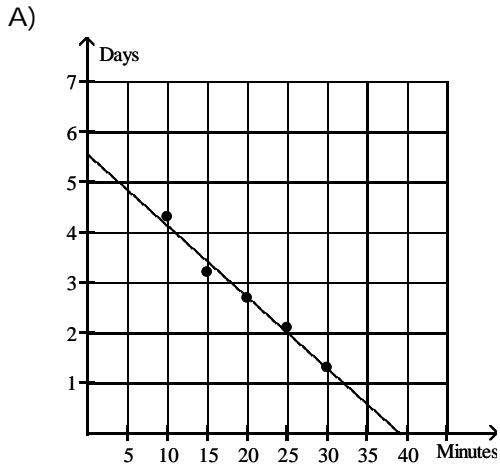

-6.7 days per minute

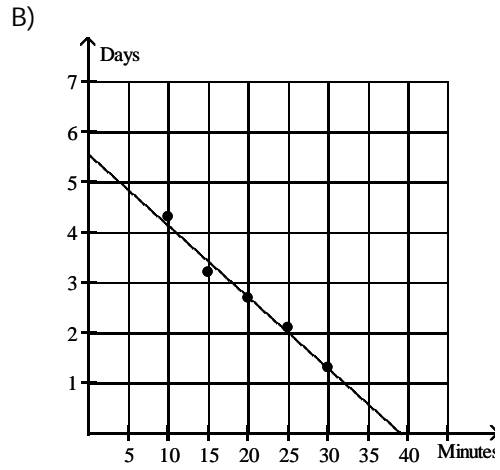

5.6 days

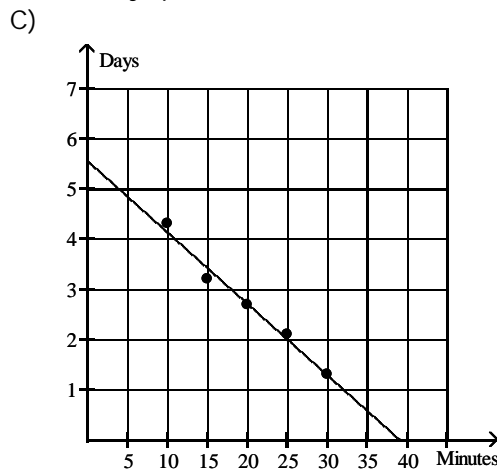

38 minutes

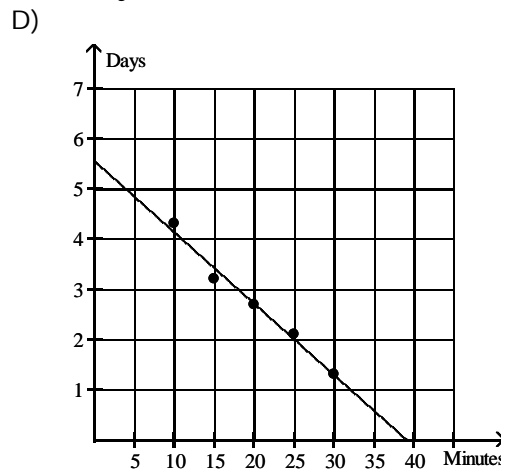

-0.14 day per minute

26) The graph below shows the number of tuberculosis deaths in the United States from 1989 to 1998. 26) _____

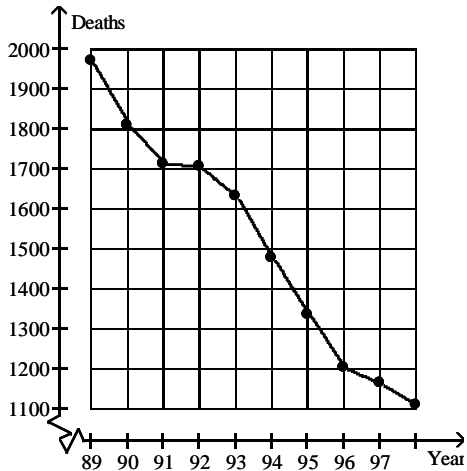

Estimate the average rate of change in tuberculosis deaths from 1991 to 1993.

- A) About -45 deaths per year
 B) About -30 deaths per year
 C) About -0.4 deaths per year
 D) About -80 deaths per year

Use the graph to evaluate the limit.

27) $\lim_{x \rightarrow -1} f(x)$

27) _____

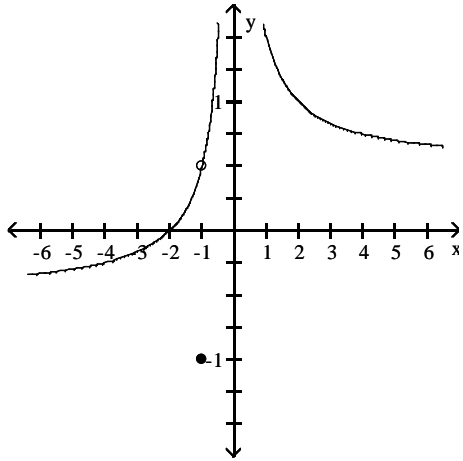

A) -1

B) $-\frac{1}{2}$

C) ∞

D) $\frac{1}{2}$

28) $\lim_{x \rightarrow 0} f(x)$

28) _____

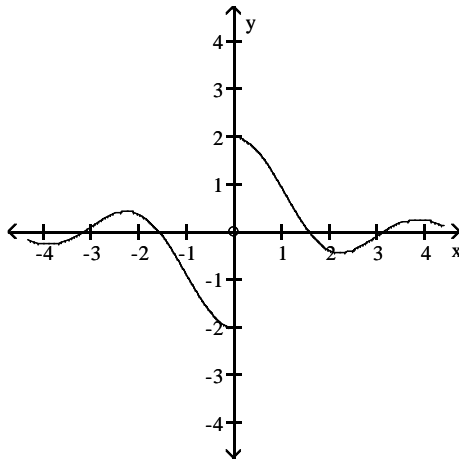

A) does not exist

B) -2

C) 0

D) 2

29) $\lim_{x \rightarrow 0} f(x)$

29) _____

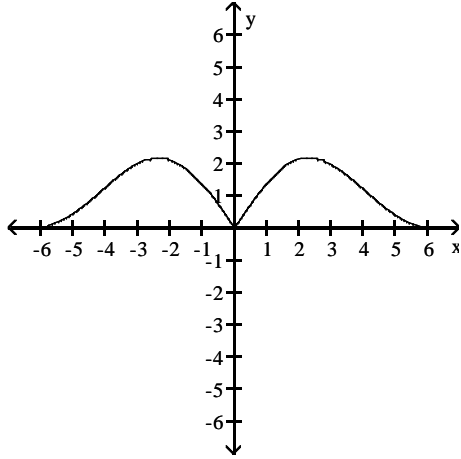

A) -3

B) 3

C) 0

D) does not exist

30) $\lim_{x \rightarrow 0} f(x)$

30) _____

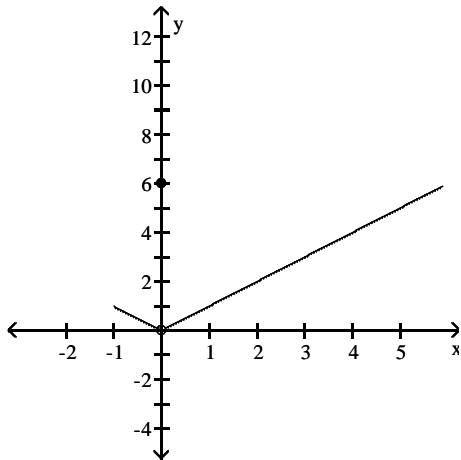

A) -1

B) 0

C) 6

D) does not exist

31) $\lim_{x \rightarrow 0} f(x)$

31) _____

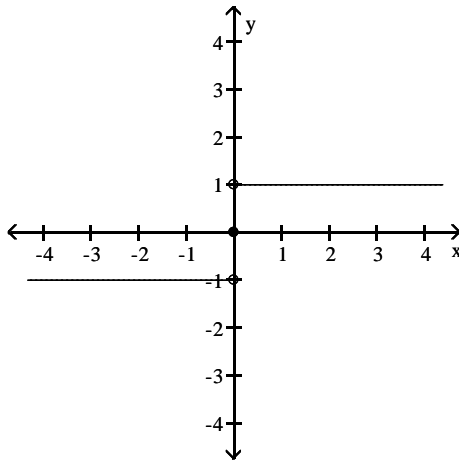

A) ∞

B) does not exist

C) -1

D) 1

32) $\lim_{x \rightarrow 0} f(x)$

32) _____

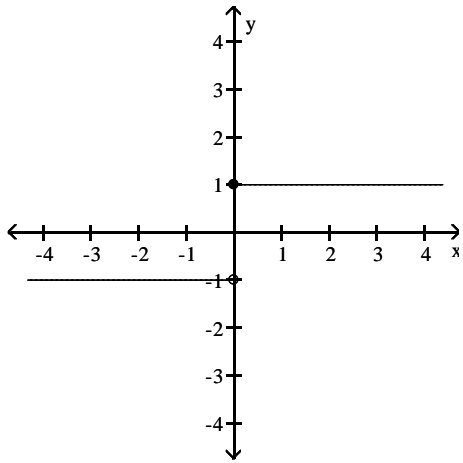

A) 1

B) ∞

C) -1

D) does not exist

33) $\lim_{x \rightarrow 0} f(x)$

33) _____

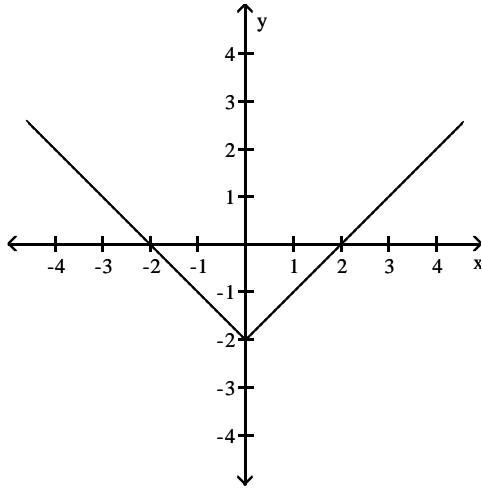

- A) does not exist B) 0 C) -2 D) 2

34) $\lim_{x \rightarrow 0} f(x)$

34) _____

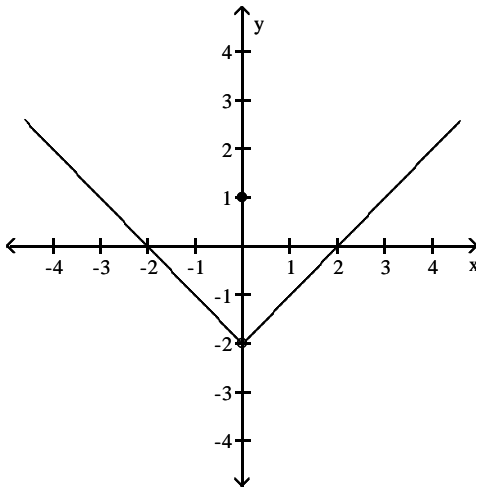

- A) 1 B) 0 C) does not exist D) -2

35) $\lim_{x \rightarrow 0} f(x)$

35) _____

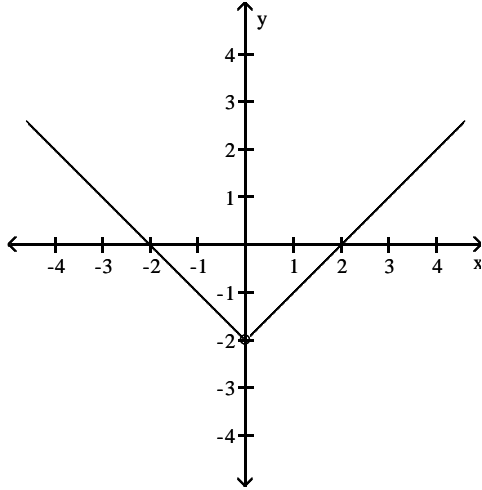

- A) does not exist B) 2 C) -1 D) -2

36) $\lim_{x \rightarrow 0} f(x)$

36) _____

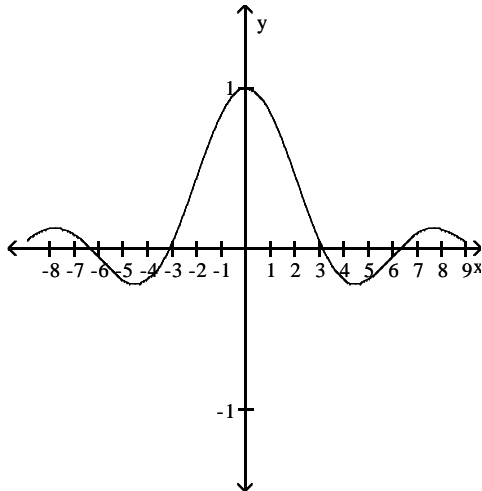

- A) does not exist B) 0 C) 1 D) -1

Find the limit.

37) $\lim_{x \rightarrow 4} (3x + 3)$

37) _____

- A) -9 B) 15 C) 6 D) 3

38) $\lim_{x \rightarrow 2} (x^2 + 8x - 2)$

38) _____

- A) 18 B) 0 C) -18 D) does not exist

39) $\lim_{x \rightarrow 0} (x^2 - 5)$

39) _____

- A) does not exist B) 5 C) -5 D) 0

40) $\lim_{x \rightarrow 0} (\sqrt{x} - 2)$ 40) _____
 A) 0 B) 2 C) -2 D) does not exist

41) $\lim_{x \rightarrow 2} (x^3 + 5x^2 - 7x + 1)$ 41) _____
 A) 29 B) does not exist C) 0 D) 15

42) $\lim_{x \rightarrow 2} (3x^5 - 2x^4 + 4x^3 + x^2 + 5)$ 42) _____
 A) 41 B) 105 C) 169 D) 57

43) $\lim_{x \rightarrow 7} \sqrt{x^2 + 8x + 16}$ 43) _____
 A) 121 B) ± 11 C) 11 D) does not exist

44) $\lim_{x \rightarrow -1} \frac{x}{3x + 2}$ 44) _____
 A) 1 B) $-\frac{1}{5}$ C) 0 D) does not exist

Find the limit if it exists.

45) $\lim_{x \rightarrow 20} \sqrt{5}$ 45) _____
 A) $2\sqrt{5}$ B) 20 C) 5 D) $\sqrt{5}$

46) $\lim_{x \rightarrow -1} (5x - 10)$ 46) _____
 A) -5 B) 15 C) -15 D) 5

47) $\lim_{x \rightarrow -20} (10 - 9x)$ 47) _____
 A) 170 B) 190 C) -190 D) -170

48) $\lim_{x \rightarrow -10} (4x^2 - 10x - 9)$ 48) _____
 A) 491 B) 309 C) 509 D) 291

49) $\lim_{x \rightarrow 6} 5x(x + 5)(x - 8)$ 49) _____
 A) -60 B) 660 C) 4620 D) -660

50) $\lim_{x \rightarrow \frac{3}{4}} 4x \left(x - \frac{1}{2} \right)$ 50) _____
 A) $\frac{15}{4}$ B) $\frac{3}{16}$ C) 1 D) $\frac{3}{4}$

51) $\lim_{x \rightarrow 256} x^{3/4}$ 51) _____
 A) $\frac{3}{4}$ B) 192 C) 256 D) 64

52) $\lim_{x \rightarrow -2} (x + 3)^2(x - 3)^3$ 52) _____
 A) 1 B) -3125 C) -125 D) 25

53) $\lim_{x \rightarrow -3} \sqrt{9x + 89}$ 53) _____
 A) $-\sqrt{62}$ B) -62 C) $\sqrt{62}$ D) 62

54) $\lim_{x \rightarrow -3} (x - 24)^{1/3}$ 54) _____
 A) 3 B) -3 C) 1 D) 9

Find the limit, if it exists.

55) $\lim_{x \rightarrow 17} \frac{1}{x - 17}$ 55) _____
 A) 0 B) Does not exist C) 17 D) 34

56) $\lim_{x \rightarrow 0} \frac{x^3 - 6x + 8}{x - 2}$ 56) _____
 A) -4 B) Does not exist C) 0 D) 4

57) $\lim_{x \rightarrow 1} \frac{2x - 7}{4x + 5}$ 57) _____
 A) $-\frac{1}{2}$ B) Does not exist C) $-\frac{7}{5}$ D) $-\frac{5}{9}$

58) $\lim_{x \rightarrow 1} \frac{3x^2 + 7x - 2}{3x^2 - 4x - 2}$ 58) _____
 A) 0 B) $-\frac{7}{4}$ C) Does not exist D) $-\frac{8}{3}$

59) $\lim_{x \rightarrow 6} \frac{x + 6}{(x - 6)^2}$ 59) _____
 A) 6 B) -6 C) 0 D) Does not exist

60) $\lim_{x \rightarrow 5} \frac{x^2 - 2x - 15}{x + 3}$ 60) _____
 A) -8 B) 5 C) 0 D) Does not exist

- 61) $\lim_{h \rightarrow 0} \frac{2}{\sqrt{3h+4} + 2}$ 61) _____
 A) 2 B) 1 C) 1/2 D) Does not exist
- 62) $\lim_{h \rightarrow 0} \frac{17x + h}{x^3(x - h)}$ 62) _____
 A) $\frac{17}{x^3}$ B) 17x C) Does not exist D) $\frac{17}{x^4}$
- 63) $\lim_{x \rightarrow 0} \frac{\sqrt{1+x} - 1}{x}$ 63) _____
 A) 1/2 B) 1/4 C) 0 D) Does not exist
- 64) $\lim_{h \rightarrow 0} \frac{(1+h)^{1/3} - 1}{h}$ 64) _____
 A) Does not exist B) 1/3 C) 3 D) 0
- 65) $\lim_{x \rightarrow 0} \frac{x^3 + 12x^2 - 5x}{5x}$ 65) _____
 A) 5 B) -1 C) Does not exist D) 0
- 66) $\lim_{x \rightarrow 1} \frac{x^4 - 1}{x - 1}$ 66) _____
 A) 2 B) Does not exist C) 0 D) 4
- 67) $\lim_{x \rightarrow 4} \frac{x^2 - 16}{x - 4}$ 67) _____
 A) 1 B) 8 C) Does not exist D) 4
- 68) $\lim_{x \rightarrow -6} \frac{x^2 + 13x + 42}{x + 6}$ 68) _____
 A) Does not exist B) 156 C) 1 D) 13
- 69) $\lim_{x \rightarrow 1} \frac{x^2 + 7x - 8}{x - 1}$ 69) _____
 A) Does not exist B) 9 C) 7 D) 0
- 70) $\lim_{x \rightarrow 3} \frac{x^2 + 3x - 18}{x^2 - 9}$ 70) _____
 A) 0 B) $-\frac{1}{2}$ C) Does not exist D) $\frac{3}{2}$

71) $\lim_{x \rightarrow 1} \frac{x^2 - 1}{x^2 - 4x + 3}$ 71) _____
 A) Does not exist B) - 1 C) $-\frac{1}{2}$ D) 0

72) $\lim_{x \rightarrow 5} \frac{x^2 - 12x + 35}{x^2 - 12x + 35}$ 72) _____
 A) - 6 B) Does not exist C) 1 D) - 1

73) $\lim_{h \rightarrow 0} \frac{(x+h)^3 - x^3}{h}$ 73) _____
 A) $3x^2 + 3xh + h^2$ B) $3x^2$ C) 0 D) Does not exist

74) $\lim_{x \rightarrow 6} \frac{|6-x|}{6-x}$ 74) _____
 A) 1 B) 0 C) Does not exist D) -1

Find the limit.

75) $\lim_{x \rightarrow 0} (5 \sin x - 1)$ 75) _____
 A) 5 B) -1 C) $5 - 1$ D) 0

76) $\lim_{x \rightarrow -\pi} \sqrt{x+7} \cos(x + \pi)$ 76) _____
 A) $-\sqrt{7-\pi}$ B) 0 C) 1 D) $\sqrt{7-\pi}$

77) $\lim_{x \rightarrow 0} \sqrt{8 + \cos^2 x}$ 77) _____
 A) 3 B) $2\sqrt{2}$ C) 8 D) 9

Give an appropriate answer.

78) Suppose $\lim_{x \rightarrow 0} f(x) = 1$ and $\lim_{x \rightarrow 0} g(x) = -3$. Name the limit rules that are used to accomplish steps 78) _____

(a), (b), and (c) of the following calculation.

$$\lim_{x \rightarrow 0} \frac{-3f(x) - 5g(x)}{(f(x) + 3)^{1/2}} \stackrel{(a)}{=} \frac{\lim_{x \rightarrow 0} (-3f(x) - 5g(x))}{\lim_{x \rightarrow 0} (f(x) + 3)^{1/2}}$$

$$\stackrel{(b)}{=} \frac{\lim_{x \rightarrow 0} -3f(x) - \lim_{x \rightarrow 0} 5g(x)}{(\lim_{x \rightarrow 0} (f(x) + 3))^{1/2}} \stackrel{(c)}{=} \frac{-3 \lim_{x \rightarrow 0} f(x) - 5 \lim_{x \rightarrow 0} g(x)}{(\lim_{x \rightarrow 0} f(x) + \lim_{x \rightarrow 0} 3)^{1/2}}$$

$$= \frac{-3 + 15}{(1 + 3)^{1/2}} = 6$$

- A) (a) Difference Rule
 (b) Power Rule
 (c) Sum Rule
 B) (a) Quotient Rule
 (b) Difference Rule
 (c) Constant Multiple Rule
 C) (a) Quotient Rule
 (b) Difference Rule, Power Rule
 (c) Constant Multiple Rule and Sum Rule
 D) (a) Quotient Rule
 (b) Difference Rule, Sum Rule
 (c) Constant Multiple Rule and Power Rule

79) Let $\lim_{x \rightarrow -6} f(x) = -7$ and $\lim_{x \rightarrow -6} g(x) = -5$. Find $\lim_{x \rightarrow -6} [f(x) - g(x)]$. 79) _____

- A) -6 B) -2 C) -12 D) -7

80) Let $\lim_{x \rightarrow -7} f(x) = 2$ and $\lim_{x \rightarrow -7} g(x) = 6$. Find $\lim_{x \rightarrow -7} [f(x) \cdot g(x)]$. 80) _____

- A) 6 B) 12 C) 8 D) -7

81) Let $\lim_{x \rightarrow 4} f(x) = -5$ and $\lim_{x \rightarrow 4} g(x) = -8$. Find $\lim_{x \rightarrow 4} \frac{f(x)}{g(x)}$. 81) _____

- A) $\frac{8}{5}$ B) 4 C) $\frac{5}{8}$ D) 3

82) Let $\lim_{x \rightarrow -9} f(x) = 64$. Find $\lim_{x \rightarrow -9} \log_4 f(x)$. 82) _____

- A) 81 B) 3 C) -9 D) $\frac{3}{4}$

83) Let $\lim_{x \rightarrow 10} f(x) = 49$. Find $\lim_{x \rightarrow 10} \sqrt{f(x)}$. 83) _____

- A) 49 B) 2.6458 C) 10 D) 7

- 84) Let $\lim_{x \rightarrow 3} f(x) = 7$ and $\lim_{x \rightarrow 3} g(x) = -8$. Find $\lim_{x \rightarrow 3} [f(x) + g(x)]^2$. 84) _____
 A) 15 B) -1 C) 113 D) 1
- 85) Let $\lim_{x \rightarrow 8} f(x) = 3$. Find $\lim_{x \rightarrow 8} (-2)^{f(x)}$. 85) _____
 A) 3 B) -8 C) -2 D) 256
- 86) Let $\lim_{x \rightarrow 9} f(x) = 32$. Find $\lim_{x \rightarrow 9} \sqrt[5]{f(x)}$. 86) _____
 A) 5 B) 9 C) 2 D) 32
- 87) Let $\lim_{x \rightarrow -8} f(x) = 6$ and $\lim_{x \rightarrow -8} g(x) = -5$. Find $\lim_{x \rightarrow -8} \left[\frac{8f(x) - 10g(x)}{7 + g(x)} \right]$. 87) _____
 A) 49 B) $-\frac{22}{7}$ C) -1 D) -8

Evaluate $\lim_{h \rightarrow 0} \frac{f(x_0 + h) - f(x_0)}{h}$ for the given x_0 and function f .

- 88) $f(x) = 4x^2$ for $x_0 = -2$ 88) _____
 A) -8 B) 16 C) Does not exist D) -16
- 89) $f(x) = 3x^2 - 4$ for $x_0 = -2$ 89) _____
 A) 12 B) -12 C) Does not exist D) -16
- 90) $f(x) = 5x + 7$ for $x_0 = 8$ 90) _____
 A) 40 B) 5 C) 47 D) Does not exist
- 91) $f(x) = \frac{x}{4} + 3$ for $x_0 = 6$ 91) _____
 A) $\frac{9}{2}$ B) $\frac{3}{2}$ C) Does not exist D) $\frac{1}{4}$
- 92) $f(x) = \frac{1}{x}$ for $x_0 = -2$ 92) _____
 A) $-\frac{1}{2}$ B) $-\frac{1}{4}$ C) Does not exist D) 2
- 93) $f(x) = 4\sqrt{x}$ for $x_0 = 4$ 93) _____
 A) 4 B) Does not exist C) 1 D) 8
- 94) $f(x) = \sqrt{x}$ for $x_0 = 5$ 94) _____
 A) $\frac{\sqrt{5}}{10}$ B) $\frac{5}{2}$ C) Does not exist D) $\frac{\sqrt{5}}{5}$

- 95) $f(x) = 2\sqrt{x} + 5$ for $x_0 = 4$ 95) _____
 A) 4 B) Does not exist C) 2 D) $\frac{1}{2}$

Provide an appropriate response.

- 96) It can be shown that the inequalities $-x \leq x \cos\left(\frac{1}{x}\right) \leq x$ hold for all values of $x \geq 0$. 96) _____

Find $\lim_{x \rightarrow 0} x \cos\left(\frac{1}{x}\right)$ if it exists.

- A) 0 B) 1 C) does not exist D) 0.0007

- 97) The inequality $1 - \frac{x^2}{2} < \frac{\sin x}{x} < 1$ holds when x is measured in radians and $|x| < 1$. 97) _____

Find $\lim_{x \rightarrow 0} \frac{\sin x}{x}$ if it exists.

- A) 0.0007 B) does not exist C) 0 D) 1

- 98) If $x^3 \leq f(x) \leq x$ for x in $[-1,1]$, find $\lim_{x \rightarrow 0} f(x)$ if it exists. 98) _____

- A) does not exist B) 0 C) 1 D) -1

Use a graphing calculator to graph f near x_0 and use Zoom and Trace to estimate the y -value on the graph as $x \rightarrow x_0$.

- 99) $\lim_{x \rightarrow 3} \frac{x^2 - 9}{\sqrt{x^2 + 7} - 4}$ 99) _____

- A) $\frac{1}{4}$ B) 8 C) 4 D) 3

- 100) $\lim_{x \rightarrow -1} \frac{x^2 - 1}{\sqrt{x^2 + 3} - 2}$ 100) _____

- A) 4 B) 2 C) $\frac{1}{4}$ D) 1

- 101) $\lim_{x \rightarrow 3} \frac{x^2 + 4x + 3}{x^2 + 2x - 3}$ 101) _____

- A) 1 B) 2 C) $\frac{1}{2}$ D) 0

- 102) $\lim_{x \rightarrow 3} \frac{x^2 - 9}{|x| - 3}$ 102) _____

- A) 0 B) -6 C) 3 D) 6

Use the table of values of f to estimate the limit.

103) Let $f(x) = x^2 + 8x - 2$, find $\lim_{x \rightarrow 2} f(x)$.

103) _____

| | | | | | | |
|--------|-----|------|-------|-------|------|-----|
| x | 1.9 | 1.99 | 1.999 | 2.001 | 2.01 | 2.1 |
| $f(x)$ | | | | | | |

A)

| | | | | | | |
|--------|-------|-------|-------|-------|-------|-------|
| x | 1.9 | 1.99 | 1.999 | 2.001 | 2.01 | 2.1 |
| $f(x)$ | 5.043 | 5.364 | 5.396 | 5.404 | 5.436 | 5.763 |

; limit = ∞

B)

| | | | | | | |
|--------|--------|--------|--------|--------|--------|--------|
| x | 1.9 | 1.99 | 1.999 | 2.001 | 2.01 | 2.1 |
| $f(x)$ | 16.810 | 17.880 | 17.988 | 18.012 | 18.120 | 19.210 |

; limit = 18.0

C)

| | | | | | | |
|--------|--------|--------|--------|--------|--------|--------|
| x | 1.9 | 1.99 | 1.999 | 2.001 | 2.01 | 2.1 |
| $f(x)$ | 16.692 | 17.592 | 17.689 | 17.710 | 17.808 | 18.789 |

; limit = 17.70

D)

| | | | | | | |
|--------|-------|-------|-------|-------|-------|-------|
| x | 1.9 | 1.99 | 1.999 | 2.001 | 2.01 | 2.1 |
| $f(x)$ | 5.043 | 5.364 | 5.396 | 5.404 | 5.436 | 5.763 |

; limit = 5.40

104) Let $f(x) = \frac{x-4}{\sqrt{x}-2}$, find $\lim_{x \rightarrow 4} f(x)$.

104) _____

| | | | | | | |
|--------|-----|------|-------|-------|------|-----|
| x | 3.9 | 3.99 | 3.999 | 4.001 | 4.01 | 4.1 |
| $f(x)$ | | | | | | |

A)

| | | | | | | |
|--------|---------|---------|---------|---------|---------|---------|
| x | 3.9 | 3.99 | 3.999 | 4.001 | 4.01 | 4.1 |
| $f(x)$ | 1.19245 | 1.19925 | 1.19993 | 1.20007 | 1.20075 | 1.20745 |

; limit = ∞

B)

| | | | | | | |
|--------|---------|---------|---------|---------|---------|---------|
| x | 3.9 | 3.99 | 3.999 | 4.001 | 4.01 | 4.1 |
| $f(x)$ | 3.97484 | 3.99750 | 3.99975 | 4.00025 | 4.00250 | 4.02485 |

; limit = 4.0

C)

| | | | | | | |
|--------|---------|---------|---------|---------|---------|---------|
| x | 3.9 | 3.99 | 3.999 | 4.001 | 4.01 | 4.1 |
| $f(x)$ | 1.19245 | 1.19925 | 1.19993 | 1.20007 | 1.20075 | 1.20745 |

; limit = 1.20

D)

| | | | | | | |
|--------|---------|---------|---------|---------|---------|---------|
| x | 3.9 | 3.99 | 3.999 | 4.001 | 4.01 | 4.1 |
| $f(x)$ | 5.07736 | 5.09775 | 5.09978 | 5.10022 | 5.10225 | 5.12236 |

; limit = 5.10

105) Let $f(x) = x^2 - 5$, find $\lim_{x \rightarrow 0} f(x)$.

105) _____

| | | | | | | |
|------|------|-------|--------|-------|------|-----|
| x | -0.1 | -0.01 | -0.001 | 0.001 | 0.01 | 0.1 |
| f(x) | | | | | | |

A)

| | | | | | | |
|------|---------|---------|---------|---------|---------|---------|
| x | -0.1 | -0.01 | -0.001 | 0.001 | 0.01 | 0.1 |
| f(x) | -1.4970 | -1.4999 | -1.5000 | -1.5000 | -1.4999 | -1.4970 |

; limit = -15.0

B)

| | | | | | | |
|------|---------|---------|---------|---------|---------|---------|
| x | -0.1 | -0.01 | -0.001 | 0.001 | 0.01 | 0.1 |
| f(x) | -1.4970 | -1.4999 | -1.5000 | -1.5000 | -1.4999 | -1.4970 |

; limit = ∞

C)

| | | | | | | |
|------|---------|---------|---------|---------|---------|---------|
| x | -0.1 | -0.01 | -0.001 | 0.001 | 0.01 | 0.1 |
| f(x) | -2.9910 | -2.9999 | -3.0000 | -3.0000 | -2.9999 | -2.9910 |

; limit = -3.0

D)

| | | | | | | |
|------|---------|---------|---------|---------|---------|---------|
| x | -0.1 | -0.01 | -0.001 | 0.001 | 0.01 | 0.1 |
| f(x) | -4.9900 | -4.9999 | -5.0000 | -5.0000 | -4.9999 | -4.9900 |

; limit = -5.0

106) Let $f(x) = \frac{x-3}{x^2-4x+3}$, find $\lim_{x \rightarrow 3} f(x)$.

106) _____

| | | | | | | |
|------|-----|------|-------|-------|------|-----|
| x | 2.9 | 2.99 | 2.999 | 3.001 | 3.01 | 3.1 |
| f(x) | | | | | | |

A)

| | | | | | | |
|------|--------|--------|--------|--------|--------|--------|
| x | 2.9 | 2.99 | 2.999 | 3.001 | 3.01 | 3.1 |
| f(x) | 0.4263 | 0.4025 | 0.4003 | 0.3998 | 0.3975 | 0.3762 |

; limit = 0.4

B)

| | | | | | | |
|------|---------|---------|---------|---------|---------|---------|
| x | 2.9 | 2.99 | 2.999 | 3.001 | 3.01 | 3.1 |
| f(x) | -0.5263 | -0.5025 | -0.5003 | -0.4998 | -0.4975 | -0.4762 |

; limit = -0.5

C)

| | | | | | | |
|------|--------|--------|--------|--------|--------|--------|
| x | 2.9 | 2.99 | 2.999 | 3.001 | 3.01 | 3.1 |
| f(x) | 0.6263 | 0.6025 | 0.6003 | 0.5998 | 0.5975 | 0.5762 |

; limit = 0.6

D)

| | | | | | | |
|------|--------|--------|--------|--------|--------|--------|
| x | 2.9 | 2.99 | 2.999 | 3.001 | 3.01 | 3.1 |
| f(x) | 0.5263 | 0.5025 | 0.5003 | 0.4998 | 0.4975 | 0.4762 |

; limit = 0.5

112) If $\lim_{x \rightarrow 2} \frac{f(x)}{x^2} = 4$, find $\lim_{x \rightarrow 2} \frac{f(x)}{x}$. 112) _____
 A) 2 B) 8 C) 4 D) 16

113) If $\lim_{x \rightarrow 0} \frac{f(x)}{x} = 1$, find $\lim_{x \rightarrow 0} f(x)$. 113) _____
 A) 2 B) 1 C) 0 D) Does not exist

114) If $\lim_{x \rightarrow 0} \frac{f(x)}{x^2} = 1$, find $\lim_{x \rightarrow 0} \frac{f(x)}{x}$. 114) _____
 A) 2 B) 1 C) 0 D) Does not exist

115) If $\lim_{x \rightarrow 1} \frac{f(x) - 3}{x - 1} = 2$, find $\lim_{x \rightarrow 1} f(x)$. 115) _____
 A) 1 B) 3 C) 2 D) Does not exist

116) Find $\lim_{x \rightarrow 0} \frac{\frac{1}{x+7} - \frac{1}{7}}{x}$. 116) _____
 A) $-\frac{1}{49}$ B) 0 C) $\frac{1}{49}$ D) Does not exist

Given the interval (a, b) on the x-axis with the point x_0 inside, find the greatest value for $\delta > 0$ such that for all x , $0 < |x - x_0| < \delta \Rightarrow a < x < b$.

117) $a = 7, b = 17, x_0 = 10$ 117) _____
 A) 7 B) 1 C) 4 D) 3

118) $a = \frac{1}{9}, b = \frac{8}{9}, x_0 = \frac{4}{9}$ 118) _____
 A) $\delta = \frac{4}{9}$ B) $\delta = 3$ C) $\delta = \frac{1}{3}$ D) $\delta = \frac{2}{9}$

119) $a = 1.473, b = 2.805, x_0 = 1.808$ 119) _____
 A) $\delta = 0.997$ B) $\delta = 1$ C) $\delta = 1.332$ D) $\delta = 0.335$

Use the graph to find a $\delta > 0$ such that for all x , $0 < |x - x_0| < \delta \Rightarrow |f(x) - L| < \varepsilon$.

120)

120) _____

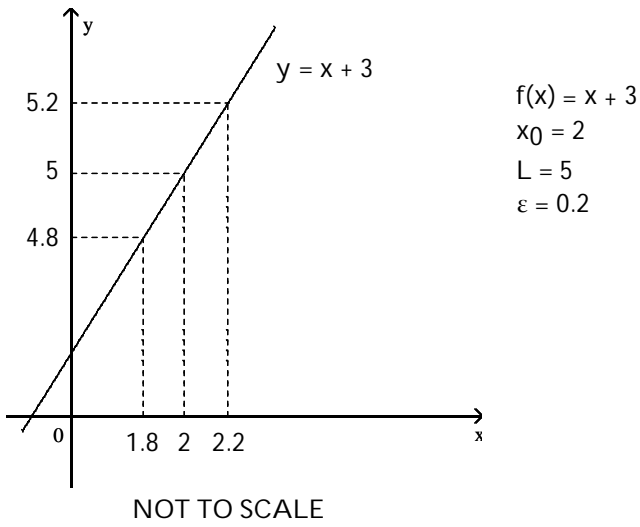

A) 0.2

B) 0.4

C) 0.1

D) 3

121)

121) _____

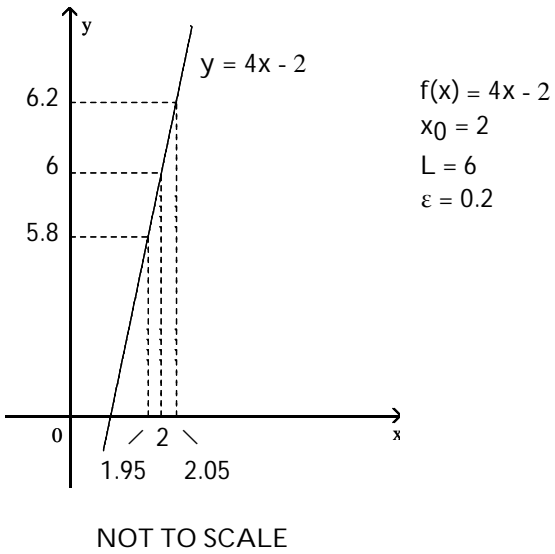

A) 0.5

B) 0.1

C) 4

D) 0.05

122)

122) _____

$f(x) = -4x - 1$
 $x_0 = -2$
 $L = 7$
 $\epsilon = 0.2$

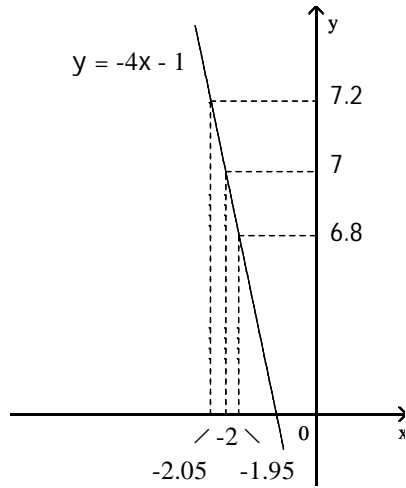

NOT TO SCALE

A) -0.05

B) 11

C) 0.5

D) 0.05

123)

123) _____

$f(x) = -x + 3$
 $x_0 = -1$
 $L = 4$
 $\epsilon = 0.2$

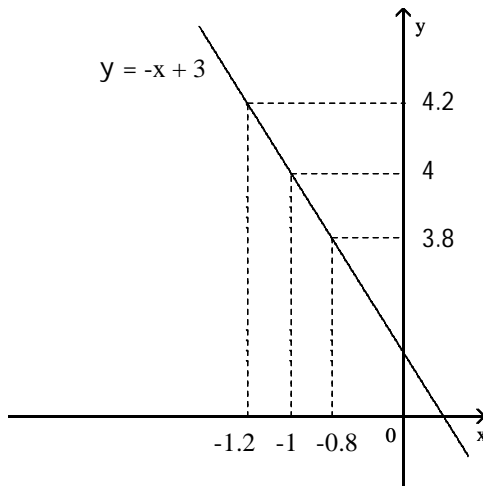

NOT TO SCALE

A) 0.4

B) -0.2

C) 0.2

D) 5

124)

124) _____

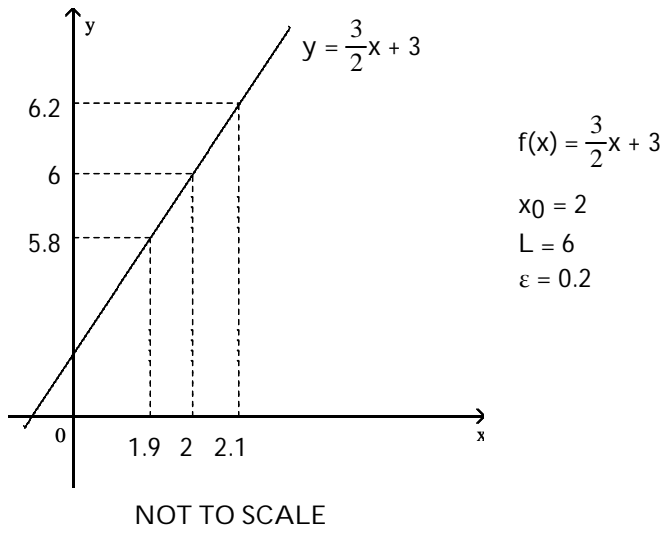

A) -0.2

B) 0.2

C) 4

D) 0.1

125)

125) _____

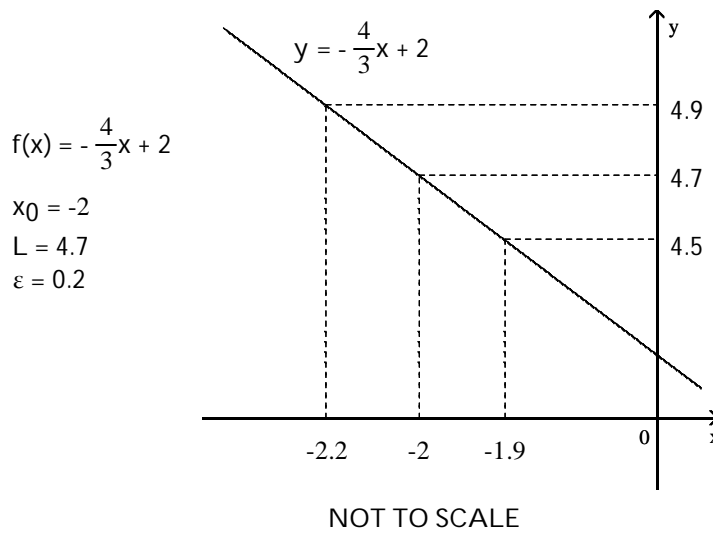

A) 6.7

B) -0.3

C) 0.3

D) 0.1

126)

126) _____

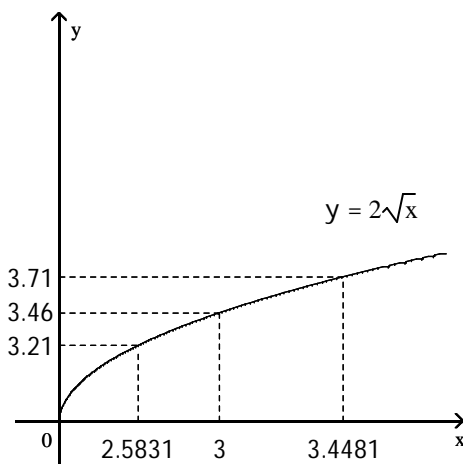

$$f(x) = 2\sqrt{x}$$

$$x_0 = 3$$

$$L = 2\sqrt{3}$$

$$\varepsilon = \frac{1}{4}$$

NOT TO SCALE

- A) 0.46 B) 0.4169 C) 0.4481 D) 0.865

127)

127) _____

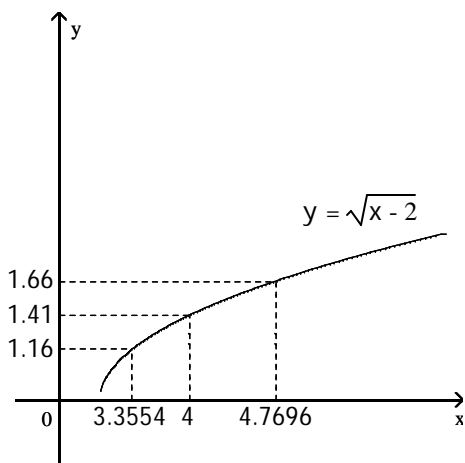

$$f(x) = \sqrt{x-2}$$

$$x_0 = 4$$

$$L = \sqrt{2}$$

$$\varepsilon = \frac{1}{4}$$

NOT TO SCALE

- A) 0.6446 B) 2.59 C) 0.7696 D) 1.4142

128)

128) _____

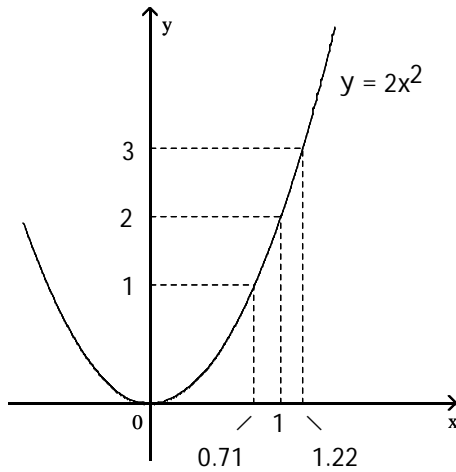

$$f(x) = 2x^2$$

$$x_0 = 1$$

$$L = 2$$

$$\varepsilon = 1$$

NOT TO SCALE

A) 0.29

B) 1

C) 0.51

D) 0.22

129)

129) _____

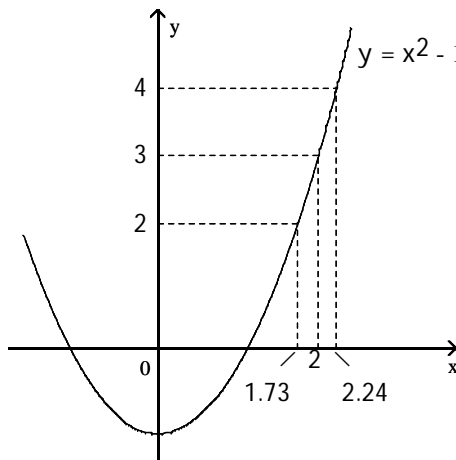

$$f(x) = x^2 - 1$$

$$x_0 = 2$$

$$L = 3$$

$$\varepsilon = 1$$

NOT TO SCALE

A) 0.24

B) 0.27

C) 1

D) 0.51

A function $f(x)$, a point x_0 , the limit of $f(x)$ as x approaches x_0 , and a positive number ε is given. Find a number $\delta > 0$ such that for all x , $0 < |x - x_0| < \delta \Rightarrow |f(x) - L| < \varepsilon$.

130) $f(x) = 3x + 8$, $L = 11$, $x_0 = 1$, and $\varepsilon = 0.01$

130) _____

A) 0.016667

B) 0.006667

C) 0.01

D) 0.003333

131) $f(x) = 6x - 5$, $L = 1$, $x_0 = 1$, and $\varepsilon = 0.01$

131) _____

A) 0.001667

B) 0.01

C) 0.003333

D) 0.000833

132) $f(x) = -2x + 4$, $L = 2$, $x_0 = 1$, and $\varepsilon = 0.01$

132) _____

A) -0.01

B) 0.005

C) 0.02

D) 0.01

- 133) $f(x) = -10x - 5$, $L = -35$, $x_0 = 3$, and $\varepsilon = 0.01$ 133) _____
 A) 0.0005 B) -0.003333 C) 0.002 D) 0.001
- 134) $f(x) = \sqrt{x+3}$, $L = 3$, $x_0 = 6$, and $\varepsilon = 1$ 134) _____
 A) 5 B) 7 C) 4 D) 16
- 135) $f(x) = \sqrt{7-x}$, $L = 2$, $x_0 = 3$, and $\varepsilon = 1$ 135) _____
 A) 4 B) 3 C) -5 D) 6
- 136) $f(x) = 5x^2$, $L = 45$, $x_0 = 3$, and $\varepsilon = 0.1$ 136) _____
 A) 3.00333 B) 0.00334 C) 0.00333 D) 2.99666
- 137) $f(x) = 1/x$, $L = 1/6$, $x_0 = 6$, and $\varepsilon = 0.1$ 137) _____
 A) 90 B) 9 C) 2.25 D) 0.375
- 138) $f(x) = mx$, $m > 0$, $L = 6m$, $x_0 = 6$, and $\varepsilon = 0.07$ 138) _____
 A) $\delta = 0.07$ B) $\delta = 6 - m$ C) $\delta = 6 + \frac{0.07}{m}$ D) $\delta = \frac{0.07}{m}$
- 139) $f(x) = mx + b$, $m > 0$, $L = (m/4) + b$, $x_0 = 1/4$, and $\varepsilon = c > 0$ 139) _____
 A) $\delta = \frac{c}{m}$ B) $\delta = \frac{c}{4}$ C) $\delta = \frac{1}{4} + \frac{c}{m}$ D) $\delta = \frac{4}{m}$

Find the limit L for the given function f , the point x_0 , and the positive number ε . Then find a number $\delta > 0$ such that, for all x , $0 < |x - x_0| < \delta \Rightarrow |f(x) - L| < \varepsilon$.

- 140) $f(x) = -4x - 1$, $x_0 = -5$, $\varepsilon = 0.08$ 140) _____
 A) $L = -21$; $\delta = 0.03$ B) $L = 19$; $\delta = 0.03$
 C) $L = 21$; $\delta = 0.02$ D) $L = 19$; $\delta = 0.02$
- 141) $f(x) = \frac{x^2 + 9x + 14}{x + 7}$, $x_0 = -7$, $\varepsilon = 0.01$ 141) _____
 A) $L = 9$; $\delta = 0.02$ B) $L = 4$; $\delta = 0.02$
 C) $L = 0$; $\delta = 0.01$ D) $L = -5$; $\delta = 0.01$
- 142) $f(x) = \sqrt{75 - 2x}$, $x_0 = -3$, $\varepsilon = 0.3$ 142) _____
 A) $L = 9$; $\delta = 2.75$ B) $L = 10$; $\delta = 2.66$
 C) $L = 9$; $\delta = 2.66$ D) $L = 9$; $\delta = 1.31$
- 143) $f(x) = \frac{30}{x}$, $x_0 = 6$, $\varepsilon = 0.2$ 143) _____
 A) $L = 5$; $\delta = 0.25$ B) $L = 5$; $\delta = 0.23$ C) $L = 5$; $\delta = 0.5$ D) $L = 5$; $\delta = 2.5$

SHORT ANSWER. Write the word or phrase that best completes each statement or answers the question.

Prove the limit statement

144) $\lim_{x \rightarrow 2} (5x - 3) = 7$ 144) _____

145) $\lim_{x \rightarrow 6} \frac{x^2 - 36}{x - 6} = 12$ 145) _____

146) $\lim_{x \rightarrow 9} \frac{3x^2 - 25x - 18}{x - 9} = 29$ 146) _____

147) $\lim_{x \rightarrow 3} \frac{1}{x} = \frac{1}{3}$ 147) _____

MULTIPLE CHOICE. Choose the one alternative that best completes the statement or answers the question.

Solve the problem.

- 148) You are asked to make some circular cylinders, each with a cross-sectional area of 10 cm^2 . To do this, you need to know how much deviation from the ideal cylinder diameter of $x_0 = 4.22 \text{ cm}$ you can allow and still have the area come within 0.1 cm^2 of the required 10 cm^2 . To find out, let $A = \pi \left(\frac{x}{2}\right)^2$ and look for the interval in which you must hold x to make $|A - 10| < 0.1$. What interval do you find?
 A) $(6.2929, 6.3561)$ B) $(2.5105, 2.5357)$ C) $(3.5504, 3.5860)$ D) $(0.5642, 0.5642)$ 148) _____

- 149) Ohm's Law for electrical circuits is stated $V = RI$, where V is a constant voltage, R is the resistance in ohms and I is the current in amperes. Your firm has been asked to supply the resistors for a circuit in which V will be 12 volts and I is to be 5 ± 0.1 amperes. In what interval does R have to lie for I to be within 0.1 amps of the target value $I_0 = 5$?
 A) $\left(\frac{10}{49}, \frac{10}{51}\right)$ B) $\left(\frac{17}{40}, \frac{49}{120}\right)$ C) $\left(\frac{40}{17}, \frac{120}{49}\right)$ D) $\left(\frac{120}{49}, \frac{40}{17}\right)$ 149) _____

- 150) The cross-sectional area of a cylinder is given by $A = \pi D^2/4$, where D is the cylinder diameter. Find the tolerance range of D such that $|A - 10| < 0.01$ as long as $D_{\min} < D < D_{\max}$.
 A) $D_{\min} = 3.567, D_{\max} = 3.578$ B) $D_{\min} = 3.558, D_{\max} = 3.578$
 C) $D_{\min} = 3.558, D_{\max} = 3.570$ D) $D_{\min} = 3.567, D_{\max} = 3.570$ 150) _____

- 151) The current in a simple electrical circuit is given by $I = V/R$, where I is the current in amperes, V is the voltage in volts, and R is the resistance in ohms. When $V = 12 \text{ volts}$, what is a 12Ω resistor's tolerance for the current to be within 1 ± 0.01 amp?
 A) 0.1% B) 0.01% C) 10% D) 1% 151) _____

152) Select the correct statement for the definition of the limit: $\lim_{x \rightarrow x_0} f(x) = L$

152) _____

means that _____

- A) if given any number $\epsilon > 0$, there exists a number $\delta > 0$, such that for all x , $0 < |x - x_0| < \delta$ implies $|f(x) - L| < \epsilon$.
- B) if given any number $\epsilon > 0$, there exists a number $\delta > 0$, such that for all x , $0 < |x - x_0| < \delta$ implies $|f(x) - L| < \epsilon$.
- C) if given a number $\epsilon > 0$, there exists a number $\delta > 0$, such that for all x , $0 < |x - x_0| < \delta$ implies $|f(x) - L| > \epsilon$.
- D) if given any number $\epsilon > 0$, there exists a number $\delta > 0$, such that for all x , $0 < |x - x_0| < \delta$ implies $|f(x) - L| > \delta$.

153) Identify the incorrect statements about limits.

153) _____

- I. The number L is the limit of $f(x)$ as x approaches x_0 if $f(x)$ gets closer to L as x approaches x_0 .
- II. The number L is the limit of $f(x)$ as x approaches x_0 if, for any $\epsilon > 0$, there corresponds a $\delta > 0$ such that $|f(x) - L| < \epsilon$ whenever $0 < |x - x_0| < \delta$.
- III. The number L is the limit of $f(x)$ as x approaches x_0 if, given any $\epsilon > 0$, there exists a value of x for which $|f(x) - L| < \epsilon$.

- A) II and III B) I and III C) I and II D) I, II, and III

Use the graph to estimate the specified limit.

154) Find $\lim_{x \rightarrow (-1)^-} f(x)$ and $\lim_{x \rightarrow (-1)^+} f(x)$

154) _____

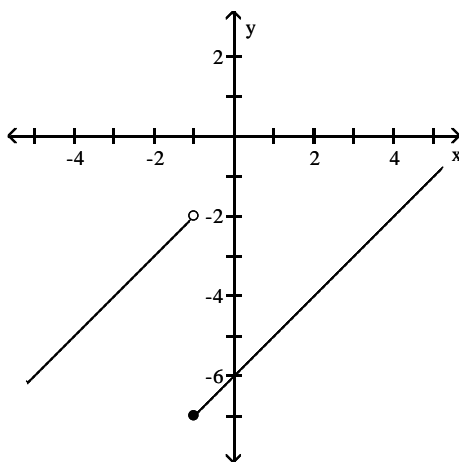

- A) -2; -7 B) -5; -2 C) -7; -5 D) -7; -2

155) Find $\lim_{x \rightarrow 0} f(x)$

155) _____

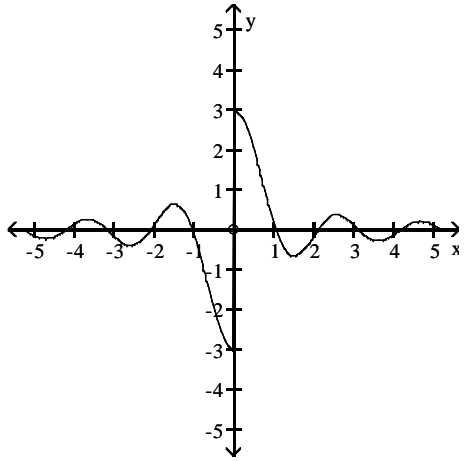

A) -3

B) 0

C) 3

D) does not exist

156) Find $\lim_{x \rightarrow 0} f(x)$

156) _____

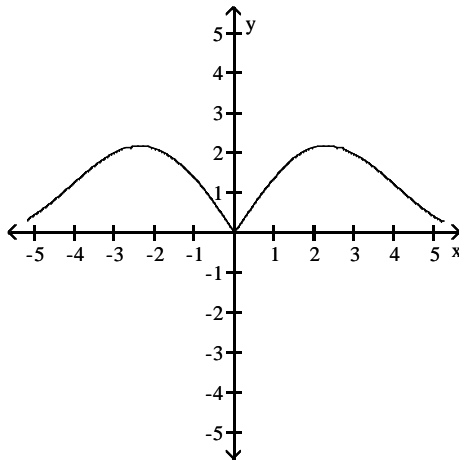

A) does not exist

B) 0

C) 3

D) -3

157) Find $\lim_{x \rightarrow 3^-} f(x)$

157) _____

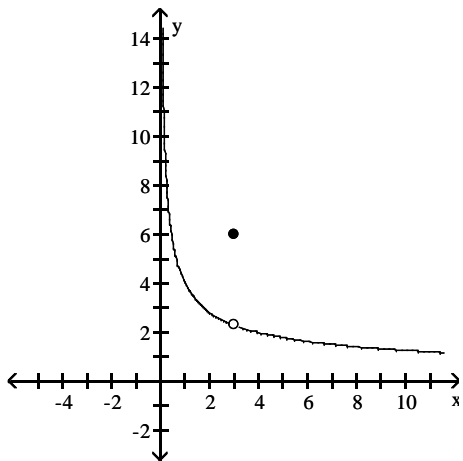

A) $-\frac{4\sqrt{3}}{3}$

B) $\frac{4}{3}$

C) $\frac{4\sqrt{3}}{3}$

D) -3

158) Find $\lim_{x \rightarrow (\pi/2)^-} f(x)$ and $\lim_{x \rightarrow (\pi/2)^+} f(x)$

158) _____

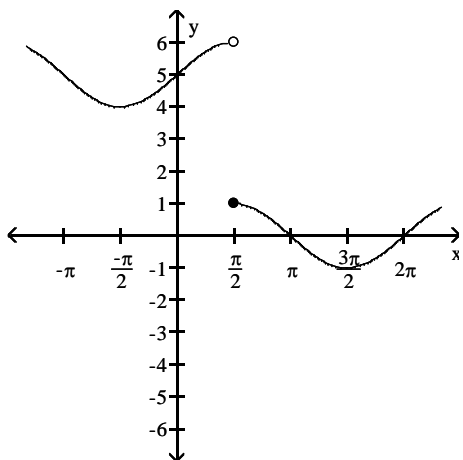

A) $\frac{\pi}{2}; \frac{\pi}{2}$

B) $\pi; \pi$

C) 1; 6

D) 6; 1

159) Find $\lim_{x \rightarrow 0^-} f(x)$ and $\lim_{x \rightarrow 0^+} f(x)$

159) _____

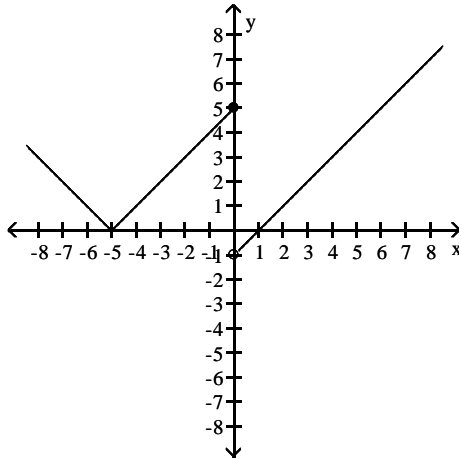

A) -5; -1

B) -1; 5

C) 5; 1

D) 5; -1

160) Find $\lim_{x \rightarrow 2^-} f(x)$ and $\lim_{x \rightarrow 2^+} f(x)$

160) _____

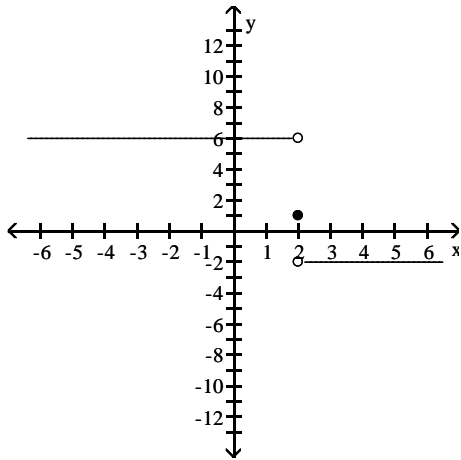

A) -2; 6

C) 6; -2

B) does not exist; does not exist

D) 1; 1

161) Find $\lim_{x \rightarrow 0} f(x)$

161) _____

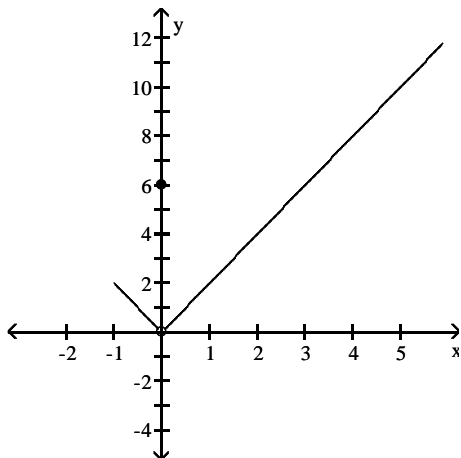

- A) 6 B) -1 C) does not exist D) 0

Determine the limit by sketching an appropriate graph.

162) $\lim_{x \rightarrow 3^-} f(x)$, where $f(x) = \begin{cases} -4x - 5 & \text{for } x < 3 \\ 5x - 4 & \text{for } x \geq 3 \end{cases}$

162) _____

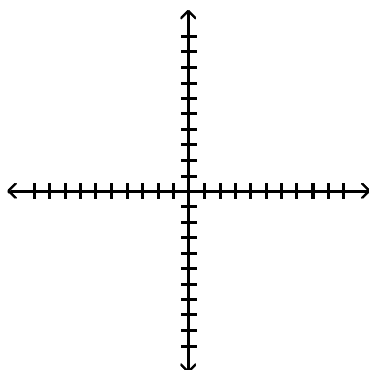

- A) 11 B) -3 C) -4 D) -17

163) $\lim_{x \rightarrow 4^+} f(x)$, where $f(x) = \begin{cases} -5x + 5 & \text{for } x < 4 \\ 5x + 6 & \text{for } x \geq 4 \end{cases}$

163) _____

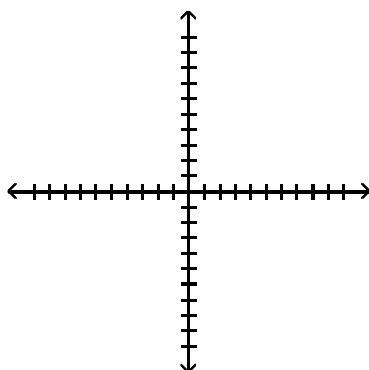

- A) 26 B) 6 C) 7 D) -15

164) $\lim_{x \rightarrow -4^+} f(x)$, where $f(x) = \begin{cases} x^2 + 6 & \text{for } x \neq -4 \\ 0 & \text{for } x = -4 \end{cases}$

164) _____

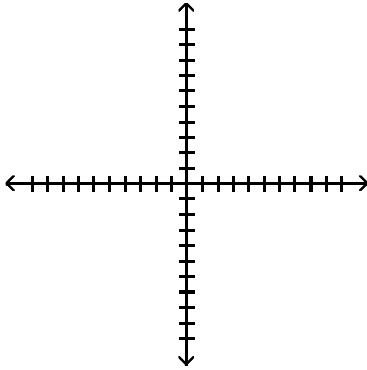

A) 10

B) 0

C) 16

D) 22

165) $\lim_{x \rightarrow 2^-} f(x)$, where $f(x) = \begin{cases} \sqrt{4 - x^2} & 0 \leq x < 2 \\ 2 & 2 \leq x < 4 \\ 4 & x = 4 \end{cases}$

165) _____

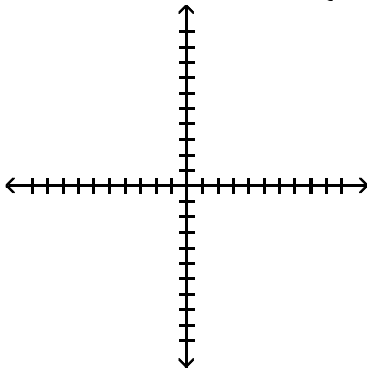

A) Does not exist

B) 2

C) 0

D) 4

166) $\lim_{x \rightarrow -4^+} f(x)$, where $f(x) = \begin{cases} x & -4 \leq x < 0, \text{ or } 0 < x \leq 3 \\ 1 & x = 0 \\ 0 & x < -4 \text{ or } x > 3 \end{cases}$

166) _____

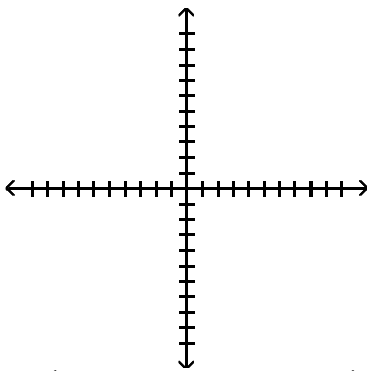

A) -0

B) 4

C) -4

D) Does not exist

Find the limit.

167) $\lim_{x \rightarrow -0.5^-} \sqrt{\frac{x+10}{x+9}}$ 167) _____

- A) $\sqrt{\frac{19}{17}}$ B) $\frac{19}{17}$ C) Does not exist D) $\sqrt{\frac{21}{19}}$

168) $\lim_{x \rightarrow 5^+} \sqrt{\frac{7x^2}{8+x}}$ 168) _____

- A) $\frac{175}{13}$ B) Does not exist C) $\sqrt{\frac{175}{13}}$ D) $\sqrt{\frac{35}{13}}$

169) $\lim_{x \rightarrow 1^+} \left(\frac{x}{x+4} \right) \left(\frac{-2x+5}{x^2+4x} \right)$ 169) _____

- A) Does not exist B) $\frac{3}{25}$ C) $\frac{3}{17}$ D) $\frac{1}{3}$

170) $\lim_{h \rightarrow 0^+} \frac{\sqrt{h^2+13h+14} - \sqrt{14}}{h}$ 170) _____

- A) $\frac{13}{\sqrt{28}}$ B) $\frac{13}{28}$ C) $\frac{13}{2\sqrt{14}}$ D) Does not exist

171) $\lim_{h \rightarrow 0^-} \frac{\sqrt{6} - \sqrt{10h^2+9h+6}}{h}$ 171) _____

- A) Does not exist B) $\frac{9}{2\sqrt{6}}$ C) $\frac{-9}{\sqrt{12}}$ D) $\frac{-9}{2\sqrt{6}}$

172) $\lim_{x \rightarrow -1^+} (x+2) \left(\frac{|x+1|}{x+1} \right)$ 172) _____

- A) Does not exist B) 3 C) -1 D) 1

173) $\lim_{x \rightarrow -2^-} (x+1) \left(\frac{|x+2|}{x+2} \right)$ 173) _____

- A) -1 B) 1 C) Does not exist D) 3

174) $\lim_{x \rightarrow 2^-} \frac{\sqrt{5x(x-2)}}{|x-2|}$ 174) _____

- A) $-\sqrt{10}$ B) $\sqrt{10}$ C) Does not exist D) 0

175) $\lim_{x \rightarrow 1^+} \frac{\sqrt{5x(x-1)}}{|x-1|}$ 175) _____

- A) Does not exist B) 0 C) $-\sqrt{5}$ D) $\sqrt{5}$

Use the graph of the greatest integer function $y = \lfloor x \rfloor$ to find the limit.

176) $\lim_{x \rightarrow 5^-} \frac{\lfloor x \rfloor}{x}$ 176) _____
 A) -5 B) 1 C) 5 D) 0

177) $\lim_{x \rightarrow 1^+} (x - \lfloor x \rfloor)$ 177) _____
 A) 2 B) 1 C) 0 D) -2

Find the limit using $\lim_{x \rightarrow 0} \frac{\sin x}{x} = 1$.

178) $\lim_{x \rightarrow 0} \frac{\sin 5x}{x}$ 178) _____
 A) 1 B) $\frac{1}{5}$ C) does not exist D) 5

179) $\lim_{x \rightarrow 0} \frac{x}{\sin 3x}$ 179) _____
 A) 1 B) 3 C) does not exist D) $\frac{1}{3}$

180) $\lim_{x \rightarrow 0} \frac{\tan 4x}{x}$ 180) _____
 A) does not exist B) $\frac{1}{4}$ C) 1 D) 4

181) $\lim_{x \rightarrow 0} \frac{\sin 5x}{\sin 4x}$ 181) _____
 A) $\frac{5}{4}$ B) does not exist C) 0 D) $\frac{4}{5}$

182) $\lim_{x \rightarrow 0} \frac{\sin 4x}{\sin 5x}$ 182) _____
 A) $\frac{5}{4}$ B) does not exist C) 0 D) $\frac{4}{5}$

183) $\lim_{x \rightarrow 0} \frac{\sin x \cos 4x}{x + x \cos 5x}$ 183) _____
 A) $\frac{1}{2}$ B) does not exist C) $\frac{4}{5}$ D) 0

- 184) $\lim_{x \rightarrow 0} 6x^2(\cot 3x)(\csc 2x)$ 184) _____
 A) $\frac{1}{3}$ B) 1 C) $\frac{1}{2}$ D) does not exist
- 185) $\lim_{x \rightarrow 0} \frac{x^2 - 2x + \sin x}{x}$ 185) _____
 A) 1 B) 0 C) -1 D) does not exist
- 186) $\lim_{x \rightarrow 0} \frac{\sin(\sin x)}{\sin x}$ 186) _____
 A) 0 B) 1 C) -1 D) does not exist
- 187) $\lim_{x \rightarrow 0} \frac{\sin 3x \cot 4x}{\cot 5x}$ 187) _____
 A) $\frac{12}{5}$ B) $\frac{15}{4}$ C) 0 D) does not exist

Provide an appropriate response.

- 188) Given $\lim_{x \rightarrow 0^-} f(x) = L_L$, $\lim_{x \rightarrow 0^+} f(x) = L_R$, and $L_L \neq L_R$, which of the following statements is true? 188) _____
 I. $\lim_{x \rightarrow 0} f(x) = L_L$
 II. $\lim_{x \rightarrow 0} f(x) = L_R$
 III. $\lim_{x \rightarrow 0} f(x)$ does not exist.
 A) I B) II C) none D) III
- 189) Given $\lim_{x \rightarrow 0^-} f(x) = L_L$, $\lim_{x \rightarrow 0^+} f(x) = L_R$, and $L_L = L_R$, which of the following statements is false? 189) _____
 I. $\lim_{x \rightarrow 0} f(x) = L_L$
 II. $\lim_{x \rightarrow 0} f(x) = L_R$
 III. $\lim_{x \rightarrow 0} f(x)$ does not exist.
 A) II B) III C) none D) I

- 190) If $\lim_{x \rightarrow 0} f(x) = L$, which of the following expressions are true? 190) _____
- I. $\lim_{x \rightarrow 0^-} f(x)$ does not exist.
 II. $\lim_{x \rightarrow 0^+} f(x)$ does not exist.
 III. $\lim_{x \rightarrow 0^-} f(x) = L$
 IV. $\lim_{x \rightarrow 0^+} f(x) = L$
- A) II and III only B) I and IV only C) III and IV only D) I and II only
- 191) If $\lim_{x \rightarrow 0^-} f(x) = 1$ and $f(x)$ is an odd function, which of the following statements are true? 191) _____
- I. $\lim_{x \rightarrow 0} f(x) = 1$
 II. $\lim_{x \rightarrow 0^+} f(x) = -1$
 III. $\lim_{x \rightarrow 0} f(x)$ does not exist.
- A) I, II, and III B) II and III only C) I and II only D) I and III only
- 192) If $\lim_{x \rightarrow 1^-} f(x) = 1$, $\lim_{x \rightarrow 1^+} f(x) = -1$, and $f(x)$ is an even function, which of the following statements are true? 192) _____
- I. $\lim_{x \rightarrow -1^-} f(x) = -1$
 II. $\lim_{x \rightarrow -1^+} f(x) = -1$
 III. $\lim_{x \rightarrow -1} f(x)$ does not exist.
- A) I, II, and III B) I and III only C) I and II only D) II and III only
- 193) Given $\varepsilon > 0$, find an interval $I = (4, 4 + \delta)$, $\delta > 0$, such that if x lies in I , then $\sqrt{x - 4} < \varepsilon$. What limit is being verified and what is its value? 193) _____
- A) $\lim_{x \rightarrow 4^+} \sqrt{x} = 4$ B) $\lim_{x \rightarrow 4^+} \sqrt{x - 4} = 0$
 C) $\lim_{x \rightarrow 4^-} \sqrt{x - 4} = 0$ D) $\lim_{x \rightarrow 0^-} \sqrt{x - 4} = 0$
- 194) Given $\varepsilon > 0$, find an interval $I = (3 - \delta, 3)$, $\delta > 0$, such that if x lies in I , then $\sqrt{3 - x} < \varepsilon$. What limit is being verified and what is its value? 194) _____
- A) $\lim_{x \rightarrow 0^-} \sqrt{3 - x} = 0$ B) $\lim_{x \rightarrow 3^-} \sqrt{3 - x} = 0$
 C) $\lim_{x \rightarrow 3^-} \sqrt{x} = 3$ D) $\lim_{x \rightarrow 3^+} \sqrt{3 - x} = 0$

Find all points where the function is discontinuous.

195)

195) _____

A) None

B) $x = 2$

C) $x = 4, x = 2$

D) $x = 4$

196)

196) _____

A) $x = -2$

B) $x = 1$

C) None

D) $x = -2, x = 1$

197)

197) _____

A) $x = -2, x = 0$

C) $x = 0, x = 2$

B) $x = -2, x = 0, x = 2$

D) $x = 2$

198)

198) _____

A) None

B) $x = -2$

C) $x = 6$

D) $x = -2, x = 6$

199)

199) _____

A) $x = 4$

C) $x = 1, x = 4, x = 5$

B) $x = 1, x = 5$

D) None

200)

200) _____

A) $x = 0, x = 1$

B) $x = 1$

C) $x = 0$

D) None

201)

201) _____

A) $x = 3$

B) $x = 0$

C) None

D) $x = 0, x = 3$

202)

202) _____

A) $x = -2, x = 2$

B) $x = -2$

C) None

D) $x = 2$

203)

203) _____

A) $x = 0$
C) None

B) $x = -2, x = 0, x = 2$
D) $x = -2, x = 2$

Answer the question.

204) Does $\lim_{x \rightarrow (-1)^+} f(x)$ exist?

204) _____

$$f(x) = \begin{cases} -x^2 + 1, & -1 \leq x < 0 \\ 2x, & 0 < x < 1 \\ -3, & x = 1 \\ -2x + 4, & 1 < x < 3 \\ 1, & 3 < x < 5 \end{cases}$$

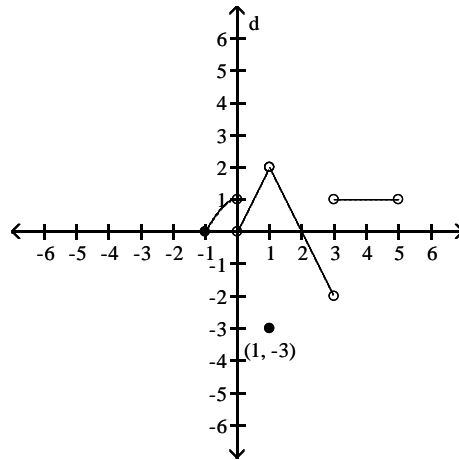

A) No

B) Yes

205) Does $\lim_{x \rightarrow -1^+} f(x) = f(-1)$?

205) _____

$$f(x) = \begin{cases} -x^2 + 1, & -1 \leq x < 0 \\ 3x, & 0 < x < 1 \\ -2, & x = 1 \\ -3x + 6, & 1 < x < 3 \\ 3, & 3 < x < 5 \end{cases}$$

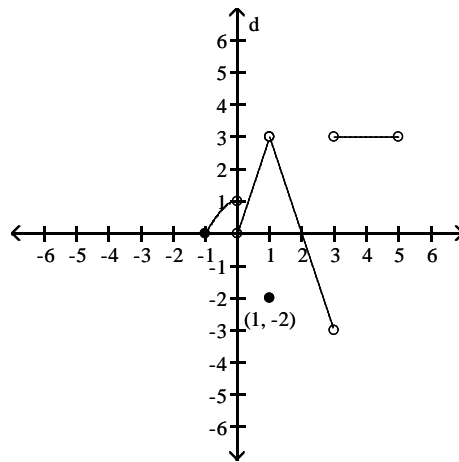

A) Yes

B) No

206) Does $\lim_{x \rightarrow 1} f(x)$ exist?

206) _____

$$f(x) = \begin{cases} -x^2 + 1, & -1 \leq x < 0 \\ 3x, & 0 < x < 1 \\ -3, & x = 1 \\ -3x + 6, & 1 < x < 3 \\ 1, & 3 < x < 5 \end{cases}$$

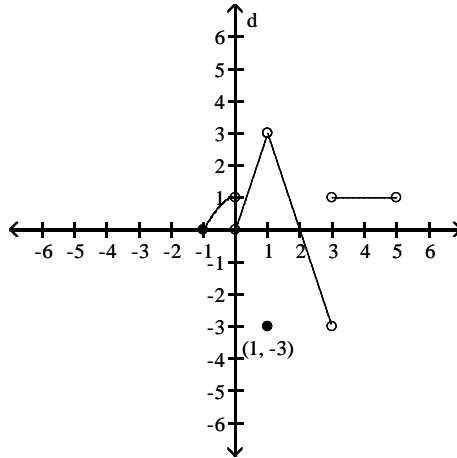

A) Yes

B) No

207) Is f continuous at $f(1)$?

207) _____

$$f(x) = \begin{cases} -x^2 + 1, & -1 \leq x < 0 \\ 5x, & 0 < x < 1 \\ -4, & x = 1 \\ -5x + 10, & 1 < x < 3 \\ 2, & 3 < x < 5 \end{cases}$$

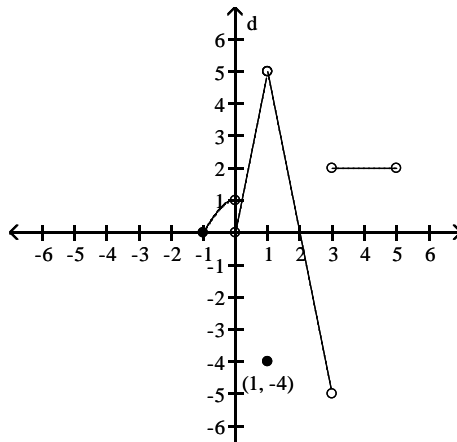

A) Yes

B) No

208) Is f continuous at $f(3)$?

208) _____

$$f(x) = \begin{cases} -x^2 + 1, & -1 \leq x < 0 \\ 4x, & 0 < x < 1 \\ -5, & x = 1 \\ -4x + 8, & 1 < x < 3 \\ 5, & 3 < x < 5 \end{cases}$$

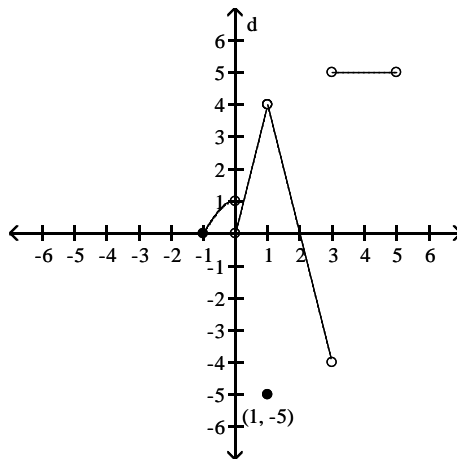

A) Yes

B) No

209) Does $\lim_{x \rightarrow 0} f(x)$ exist?

209) _____

$$f(x) = \begin{cases} x^3, & -2 < x \leq 0 \\ -3x, & 0 \leq x < 2 \\ 8, & 2 < x \leq 4 \\ 0, & x = 2 \end{cases}$$

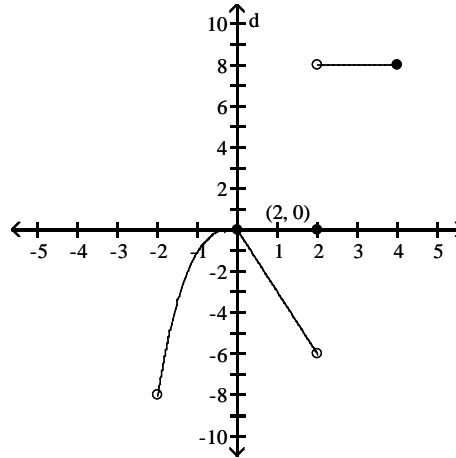

A) No

B) Yes

210) Does $\lim_{x \rightarrow 2} f(x) = f(2)$?

210) _____

$$f(x) = \begin{cases} x^3, & -2 < x \leq 0 \\ -2x, & 0 \leq x < 2 \\ 3, & 2 < x \leq 4 \\ 0, & x = 2 \end{cases}$$

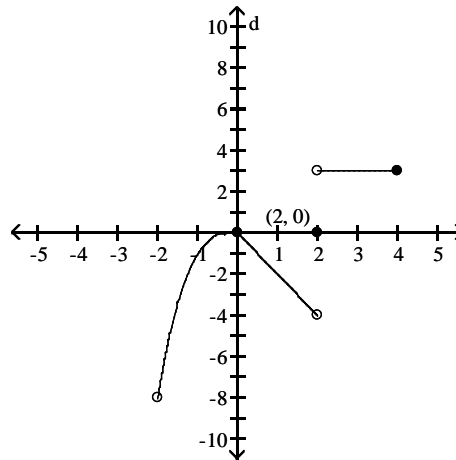

A) No

B) Yes

211) Is f continuous at $x = 0$?

211) _____

$$f(x) = \begin{cases} x^3, & -2 < x \leq 0 \\ -2x, & 0 \leq x < 2 \\ 4, & 2 < x \leq 4 \\ 0, & x = 2 \end{cases}$$

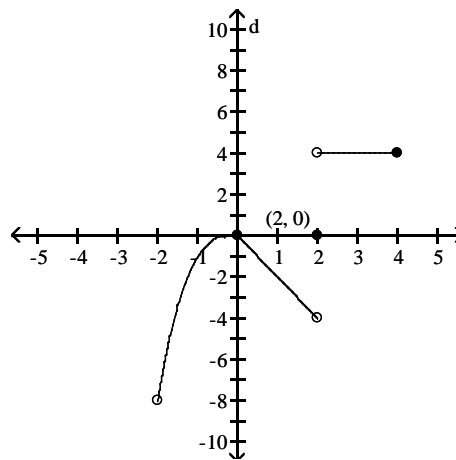

A) No

B) Yes

212) Is f continuous at $x = 4$?

212) _____

$$f(x) = \begin{cases} x^3, & -2 < x \leq 0 \\ -2x, & 0 \leq x < 2 \\ 6, & 2 < x \leq 4 \\ 0, & x = 2 \end{cases}$$

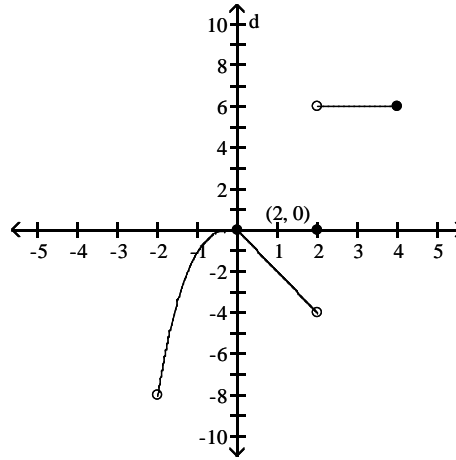

A) No

B) Yes

213) Is f continuous on $(-2, 4]$?

213) _____

$$f(x) = \begin{cases} x^3, & -2 < x \leq 0 \\ -3x, & 0 \leq x < 2 \\ 4, & 2 < x \leq 4 \\ 0, & x = 2 \end{cases}$$

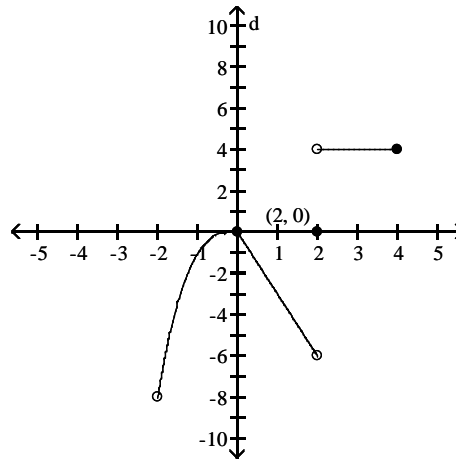

A) No

B) Yes

Solve the problem.

214) To what new value should $f(1)$ be changed to remove the discontinuity?

214) _____

$$f(x) = \begin{cases} x^2 + 2, & x < 1 \\ 1, & x = 1 \\ x + 2, & x > 1 \end{cases}$$

A) 3

B) 4

C) 1

D) 2

215) To what new value should $f(2)$ be changed to remove the discontinuity?

215) _____

$$f(x) = \begin{cases} 2x + 2, & x < 2 \\ 8, & x = 2 \\ x + 4, & x > 2 \end{cases}$$

A) -1

B) 6

C) -2

D) 5

Find the intervals on which the function is continuous.

216) $y = \frac{1}{x+3} - 4x$

216) _____

A) continuous everywhere

B) discontinuous only when $x = -3$

C) discontinuous only when $x = 3$

D) discontinuous only when $x = -7$

217) $y = \frac{3}{(x+3)^2 + 6}$ 217) _____

- A) discontinuous only when $x = 15$ B) continuous everywhere
 C) discontinuous only when $x = -3$ D) discontinuous only when $x = -24$

218) $y = \frac{x+3}{x^2 - 7x + 10}$ 218) _____

- A) discontinuous only when $x = 2$ B) discontinuous only when $x = -5$ or $x = 2$
 C) discontinuous only when $x = -2$ or $x = 5$ D) discontinuous only when $x = 2$ or $x = 5$

219) $y = \frac{5}{x^2 - 16}$ 219) _____

- A) discontinuous only when $x = -4$ or $x = 4$
 B) discontinuous only when $x = -4$
 C) discontinuous only when $x = 16$
 D) discontinuous only when $x = -16$ or $x = 16$

220) $y = \frac{5}{|x| + 4} - \frac{x^2}{7}$ 220) _____

- A) discontinuous only when $x = -7$ or $x = -4$ B) discontinuous only when $x = -4$
 C) discontinuous only when $x = -11$ D) continuous everywhere

221) $y = \frac{\sin(5\theta)}{3\theta}$ 221) _____

- A) continuous everywhere B) discontinuous only when $\theta = 0$
 C) discontinuous only when $\theta = \pi$ D) discontinuous only when $\theta = \frac{\pi}{2}$

222) $y = \frac{4 \cos \theta}{\theta + 1}$ 222) _____

- A) discontinuous only when $\theta = -1$ B) continuous everywhere
 C) discontinuous only when $\theta = \frac{\pi}{2}$ D) discontinuous only when $\theta = 1$

223) $y = \sqrt{8x + 2}$ 223) _____

- A) continuous on the interval $\left[-\frac{1}{4}, \infty\right)$ B) continuous on the interval $\left[\frac{1}{4}, \infty\right)$
 C) continuous on the interval $\left[-\infty, -\frac{1}{4}\right]$ D) continuous on the interval $\left[-\frac{1}{4}, \infty\right)$

224) $y = \sqrt[4]{5x - 3}$ 224) _____

A) continuous on the interval $\left[-\frac{3}{5}, \infty\right)$ B) continuous on the interval $\left(\frac{3}{5}, \infty\right)$

C) continuous on the interval $\left[\frac{3}{5}, \infty\right)$ D) continuous on the interval $\left[-\infty, \frac{3}{5}\right]$

225) $y = \sqrt{x^2 - 6}$ 225) _____

A) continuous on the intervals $(-\infty, -\sqrt{6}]$ and $[\sqrt{6}, \infty)$

B) continuous everywhere

C) continuous on the interval $[\sqrt{6}, \infty)$

D) continuous on the interval $[-\sqrt{6}, \sqrt{6}]$

Find the limit and determine if the function is continuous at the point being approached.

226) $\lim_{x \rightarrow 0} \sin(2x - \sin 2x)$ 226) _____

A) does not exist; yes B) does not exist; no

C) 0; yes D) 0; no

227) $\lim_{x \rightarrow -\pi/2} \cos(5x - \cos 5x)$ 227) _____

A) does not exist; no B) does not exist; yes

C) 0; yes D) 0; no

228) $\lim_{x \rightarrow -2\pi} \sin\left(\frac{-11\pi}{2} \cos(\tan x)\right)$ 228) _____

A) 1; no B) does not exist; no

C) 1; yes D) does not exist; yes

229) $\lim_{x \rightarrow -3\pi/2} \cos\left(\frac{5\pi}{2} \cos(\tan x)\right)$ 229) _____

A) 1; no B) does not exist; yes

C) 1; yes D) does not exist; no

230) $\lim_{x \rightarrow 7} \sec(x \sec^2 x - x \tan^2 x - 1)$ 230) _____

A) sec 6; no B) does not exist; no

C) csc 6; yes D) sec 6; yes

231) $\lim_{x \rightarrow 10} \sin(x \sin^2 x + x \cos^2 x + 2)$ 231) _____

A) does not exist; no B) sin 12; yes

C) sin 12; no D) sin -8; yes

232) $\lim_{\theta \rightarrow -\pi} \tan\left(\frac{3\pi}{4} \cos(\sin \theta)\right)$ 232) _____

A) -1; no B) -1; yes

C) 0; yes D) does not exist; no

233) $\lim_{\theta \rightarrow -3\pi} \tan(\sin(-3\pi \cos(\sin \theta)))$

233) _____

- A) 0; yes
- C) 1; yes

- B) 0; no
- D) does not exist; no

Determine if the given function can be extended to a continuous function at $x = 0$. If so, approximate the extended function's value at $x = 0$ (rounded to four decimal places if necessary). If not, determine whether the function can be continuously extended from the left or from the right and provide the values of the extended functions at $x = 0$. Otherwise write "no continuous extension."

234) $f(x) = \frac{10^{2x} - 1}{x}$

234) _____

- A) $f(0) = 0$
- C) $f(0) = 0$ only from the left

- B) $f(0) = 0$ only from the right
- D) No continuous extension

235) $f(x) = \frac{\cos 2x}{|2x|}$

235) _____

- A) $f(0) = 2$
- C) $f(0) = 2$ only from the right

- B) No continuous extension
- D) $f(0) = 2$ only from the left

236) $f(x) = (1 + 2x)^{1/x}$

236) _____

- A) $f(0) = 2.7183$
- C) $f(0) = 5.4366$

- B) No continuous extension
- D) $f(0) = 7.3891$

237) $f(x) = \frac{\tan x}{x}$

237) _____

- A) No continuous extension
- C) $f(0) = 1$ only from the left

- B) $f(0) = 1$
- D) $f(0) = 1$ only from the right

Find numbers a and b , or k , so that f is continuous at every point.

238)

238) _____

$$f(x) = \begin{cases} 21, & x < -5 \\ ax + b, & -5 \leq x \leq 2 \\ -14, & x > 2 \end{cases}$$

- A) $a = -5, b = -24$
- B) $a = 21, b = -14$
- C) $a = -5, b = -4$
- D) Impossible

239)

239) _____

$$f(x) = \begin{cases} x^2, & x < -3 \\ ax + b, & -3 \leq x \leq -2 \\ x + 6, & x > -2 \end{cases}$$

- A) $a = -5, b = 6$
- B) $a = -5, b = -6$
- C) $a = 5, b = -6$
- D) Impossible

240)

240) _____

$$f(x) = \begin{cases} 8x + 3, & \text{if } x < -1 \\ kx + 2, & \text{if } x \geq -1 \end{cases}$$

- A) $k = 9$
- B) $k = 2$
- C) $k = 7$
- D) $k = -2$

241) 241) _____

$$f(x) = \begin{cases} x^2, & \text{if } x \leq 6 \\ x + k, & \text{if } x > 6 \end{cases}$$

A) $k = 30$ B) $k = 42$ C) $k = -6$ D) Impossible

242) 242) _____

$$f(x) = \begin{cases} x^2, & \text{if } x \leq 2 \\ kx, & \text{if } x > 2 \end{cases}$$

A) $k = \frac{1}{2}$ B) $k = 2$ C) $k = 4$ D) Impossible

SHORT ANSWER. Write the word or phrase that best completes each statement or answers the question.

Provide an appropriate response.

243) Use the Intermediate Value Theorem to prove that $4x^3 + 9x^2 + 2x + 8 = 0$ has a solution between -3 and -2. 243) _____

244) Use the Intermediate Value Theorem to prove that $-9x^4 + 10x^3 - 6x + 7 = 0$ has a solution between 1 and 2. 244) _____

245) Use the Intermediate Value Theorem to prove that $x(x - 3)^2 = 3$ has a solution between 2 and 4. 245) _____

246) Use the Intermediate Value Theorem to prove that $5 \sin x = x$ has a solution between $\frac{\pi}{2}$ and π . 246) _____

MULTIPLE CHOICE. Choose the one alternative that best completes the statement or answers the question.

247) Use a calculator to graph the function f to see whether it appears to have a continuous extension to the origin. If it does, use Trace and Zoom to find a good candidate for the extended function's value at $x = 0$. If the function does not appear to have a continuous extension, can it be extended to be continuous at the origin from the right or from the left? If so, what do you think the extended function's value(s) should be? 247) _____

$$f(x) = \frac{8^x - 1}{x}$$

- A) continuous extension exists at origin; $f(0) = 0$
- B) continuous extension exists from the right; $f(0) \approx 2.0766$
- C) continuous extension exists from the left; $f(0) \approx 2.0766$
- D) continuous extension exists at origin; $f(0) \approx 2.0766$

- 248) Use a calculator to graph the function f to see whether it appears to have a continuous extension to the origin. If it does, use Trace and Zoom to find a good candidate for the extended function's value at $x = 0$. If the function does not appear to have a continuous extension, can it be extended to be continuous at the origin from the right or from the left? If so, what do you think the extended function's value(s) should be? 248) _____

$$f(x) = \frac{3 \sin x}{|x|}$$

- A) continuous extension exists from the right; $f(0) = 3$
 continuous extension exists from the left; $f(0) = -3$
 B) continuous extension exists from the right; $f(0) = 1$
 continuous extension exists from the left; $f(0) = -1$
 C) continuous extension exists at origin; $f(0) = 0$
 D) continuous extension exists at origin; $f(0) = 3$

SHORT ANSWER. Write the word or phrase that best completes each statement or answers the question.

- 249) A function $y = f(x)$ is continuous on $[-3, 1]$. It is known to be positive at $x = -3$ and negative at $x = 1$. What, if anything, does this indicate about the equation $f(x) = 0$? Illustrate with a sketch. 249) _____

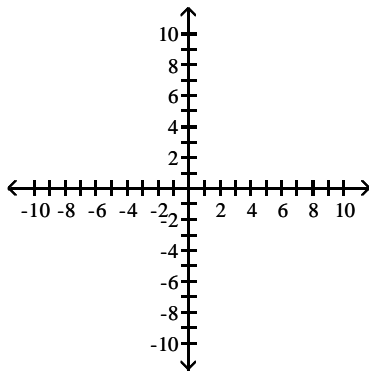

- 250) Explain why the following five statements ask for the same information. 250) _____
- (a) Find the roots of $f(x) = 3x^3 - 3x - 4$.
 (b) Find the x -coordinate of the points where the curve $y = 3x^3$ crosses the line $y = 3x + 4$.
 (c) Find all the values of x for which $3x^3 - 3x = 4$.
 (d) Find the x -coordinates of the points where the cubic curve $y = 3x^3 - 3x$ crosses the line $y = 4$.
 (e) Solve the equation $3x^3 - 3x - 4 = 0$.

- 251) If $f(x) = 2x^3 - 5x + 5$, show that there is at least one value of c for which $f(x)$ equals π . 251) _____

- 252) If functions $f(x)$ and $g(x)$ are continuous for $0 \leq x \leq 8$, could $\frac{f(x)}{g(x)}$ possibly be discontinuous at a point of $[0,8]$? Provide an example. 252) _____

- 253) Give an example of a function $f(x)$ that is continuous at all values of x except at $x = 2$, where it has a removable discontinuity. Explain how you know that f is discontinuous at $x = 2$ and how you know the discontinuity is removable. 253) _____

254) Give an example of a function $f(x)$ that is continuous for all values of x except $x = 7$, where it has a nonremovable discontinuity. Explain how you know that f is discontinuous at $x = 7$ and why the discontinuity is nonremovable. 254) _____

MULTIPLE CHOICE. Choose the one alternative that best completes the statement or answers the question.

For the function f whose graph is given, determine the limit.

255) Find $\lim_{x \rightarrow -1^-} f(x)$ and $\lim_{x \rightarrow -1^+} f(x)$. 255) _____

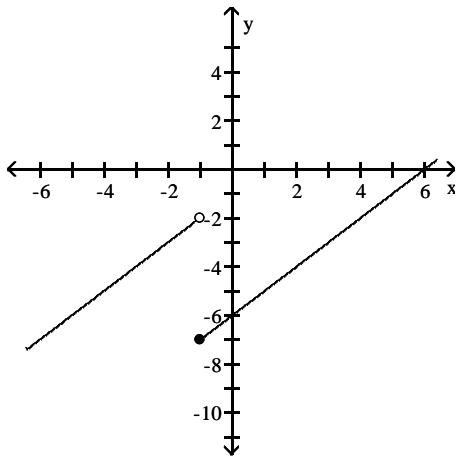

- A) -2; -7 B) -5; -2 C) -7; -5 D) -7; -2

256) Find $\lim_{x \rightarrow 2^-} f(x)$ and $\lim_{x \rightarrow 2^+} f(x)$. 256) _____

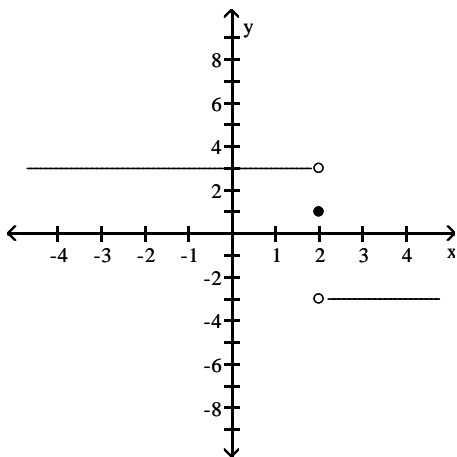

- A) 1; 1 B) -3; 3
 C) 3; -3 D) does not exist; does not exist

257) Find $\lim_{x \rightarrow 2^+} f(x)$.

257) _____

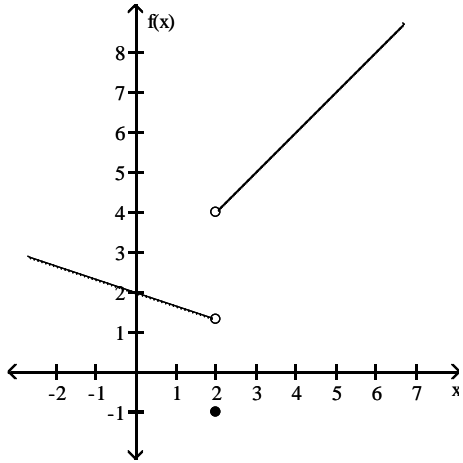

A) 5

B) -1

C) 1.3

D) 4

258) Find $\lim_{x \rightarrow 1^-} f(x)$.

258) _____

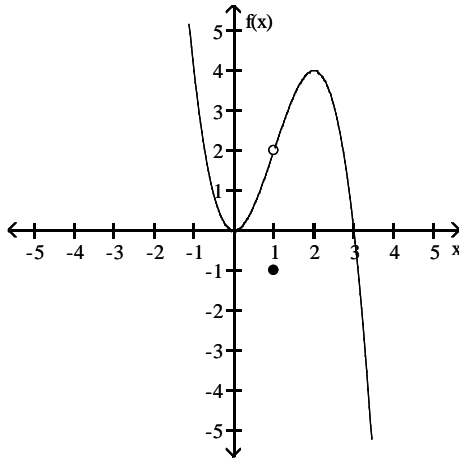

A) does not exist

B) -1

C) 2

D) $\frac{1}{2}$

259) Find $\lim_{x \rightarrow 1^+} f(x)$.

259) _____

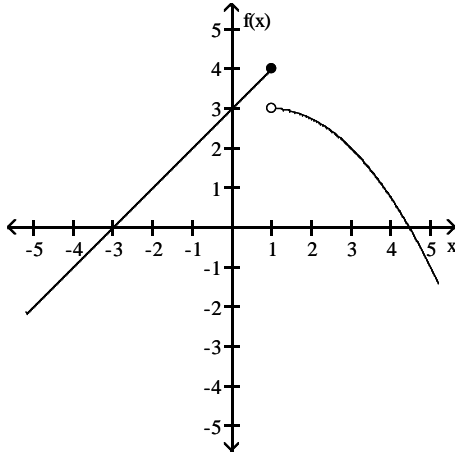

A) 3

B) $3\frac{1}{2}$

C) 4

D) does not exist

260) Find $\lim_{x \rightarrow 0} f(x)$.

260) _____

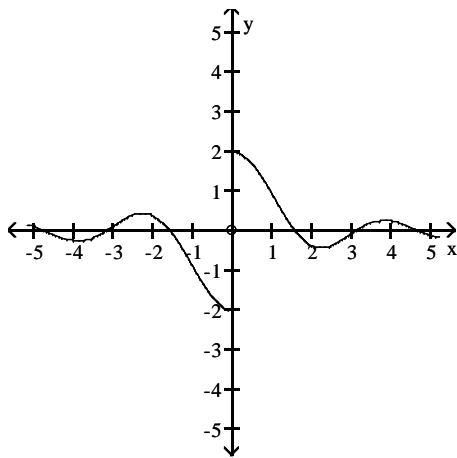

A) -2

B) 2

C) does not exist

D) 0

261) Find $\lim_{x \rightarrow 0} f(x)$.

261) _____

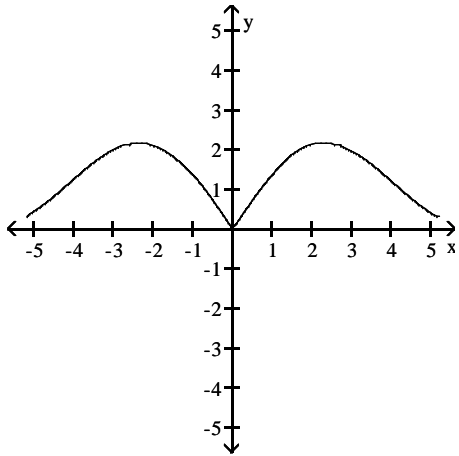

A) 3

B) -3

C) 0

D) does not exist

262) Find $\lim_{x \rightarrow 0} f(x)$.

262) _____

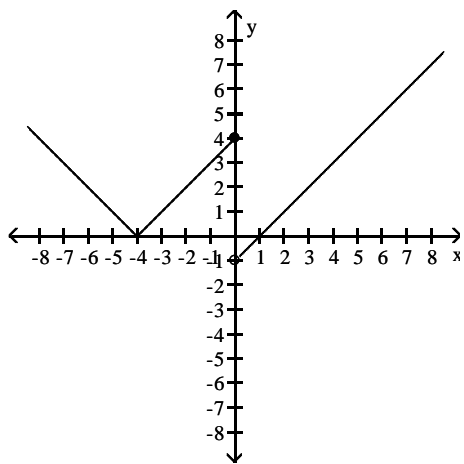

A) 4

B) 0

C) does not exist

D) -4

263) Find $\lim_{x \rightarrow -1} f(x)$.

263) _____

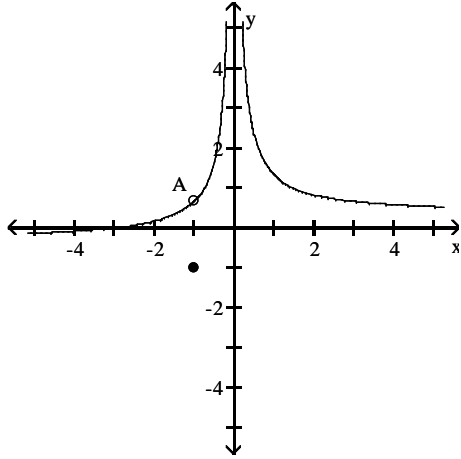

A) $\frac{2}{3}$

B) $-\frac{2}{3}$

C) -1

D) does not exist

264) Find $\lim_{x \rightarrow \infty} f(x)$.

264) _____

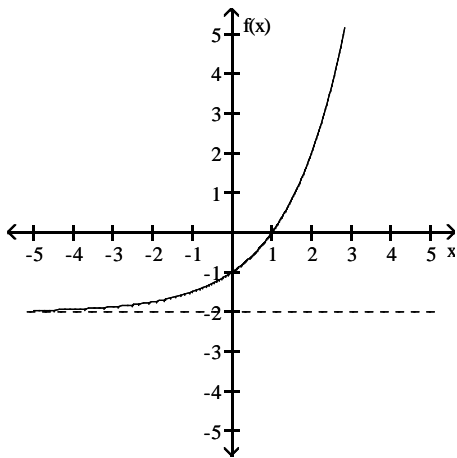

A) does not exist

B) ∞

C) -2

D) 0

Find the limit.

265) $\lim_{x \rightarrow \infty} \frac{8}{x} - 5$

265) _____

A) 3

B) -13

C) 5

D) -5

266) $\lim_{x \rightarrow -\infty} \frac{8}{2 - (3/x^2)}$

266) _____

A) $-\infty$

B) 8

C) -8

D) 4

267) $\lim_{x \rightarrow -\infty} \frac{-4 + (5/x)}{6 - (1/x^2)}$

267) _____

A) $-\infty$

B) $\frac{2}{3}$

C) $-\frac{2}{3}$

D) ∞

268) $\lim_{x \rightarrow \infty} \frac{x^2 + 7x + 10}{x^3 - 4x^2 + 3}$ 268) _____
 A) $\frac{10}{3}$ B) ∞ C) 0 D) 1

269) $\lim_{x \rightarrow -\infty} \frac{-9x^2 - 3x + 14}{-6x^2 - 6x + 15}$ 269) _____
 A) $\frac{3}{2}$ B) 1 C) ∞ D) $\frac{14}{15}$

270) $\lim_{x \rightarrow \infty} \frac{4x + 1}{12x - 7}$ 270) _____
 A) ∞ B) $\frac{1}{3}$ C) 0 D) $-\frac{1}{7}$

271) $\lim_{x \rightarrow \infty} \frac{8x^3 - 2x^2 + 3x}{-x^3 - 2x + 6}$ 271) _____
 A) ∞ B) 8 C) -8 D) $\frac{3}{2}$

272) $\lim_{x \rightarrow -\infty} \frac{5x^3 + 2x^2}{x - 6x^2}$ 272) _____
 A) 5 B) $-\infty$ C) $-\frac{1}{3}$ D) ∞

273) $\lim_{x \rightarrow -\infty} \frac{\cos 3x}{x}$ 273) _____
 A) $-\infty$ B) 3 C) 1 D) 0

Divide numerator and denominator by the highest power of x in the denominator to find the limit.

274) $\lim_{x \rightarrow \infty} \sqrt{\frac{49x^2}{6 + 16x^2}}$ 274) _____
 A) $\frac{49}{6}$ B) $\frac{49}{16}$ C) does not exist D) $\frac{7}{4}$

275) $\lim_{x \rightarrow \infty} \sqrt{\frac{49x^2 + x - 3}{(x - 15)(x + 1)}}$ 275) _____
 A) ∞ B) 0 C) 7 D) 49

276) $\lim_{x \rightarrow \infty} \frac{3\sqrt{x} + x^{-1}}{-4x + 3}$ 276) _____
 A) $-\frac{3}{4}$ B) ∞ C) 0 D) $\frac{1}{-4}$

277) $\lim_{x \rightarrow \infty} \frac{4x^{-1} - 3x^{-3}}{5x^{-2} + x^{-5}}$ 277) _____
 A) $\frac{4}{5}$ B) ∞ C) $-\infty$ D) 0

278) $\lim_{x \rightarrow -\infty} \frac{\sqrt[3]{x} + 6x - 5}{-2x + x^{2/3} + 4}$ 278) _____
 A) $-\infty$ B) $-\frac{1}{3}$ C) 0 D) -3

279) $\lim_{t \rightarrow \infty} \frac{\sqrt{81t^2 - 729}}{t - 9}$ 279) _____
 A) does not exist B) 81 C) 9 D) 729

280) $\lim_{t \rightarrow \infty} \frac{\sqrt{25t^2 - 125}}{t - 5}$ 280) _____
 A) does not exist B) 5 C) 25 D) 125

281) $\lim_{x \rightarrow \infty} \frac{7x + 2}{\sqrt{2x^2 + 1}}$ 281) _____
 A) $\frac{7}{2}$ B) ∞ C) 0 D) $\frac{7}{\sqrt{2}}$

Find the limit.

282) $\lim_{x \rightarrow -2} \frac{1}{x + 2}$ 282) _____
 A) ∞ B) $-\infty$ C) Does not exist D) 1/2

283) $\lim_{x \rightarrow 6^+} \frac{1}{x - 6}$ 283) _____
 A) ∞ B) -1 C) $-\infty$ D) 0

284) $\lim_{x \rightarrow -1^-} \frac{1}{x + 1}$ 284) _____
 A) 0 B) -1 C) $-\infty$ D) ∞

285) $\lim_{x \rightarrow 4^+} \frac{1}{(x - 4)^2}$ 285) _____
 A) ∞ B) -1 C) 0 D) $-\infty$

- 286) $\lim_{x \rightarrow -2^-} \frac{7}{x^2 - 4}$ 286) _____
 A) $-\infty$ B) 0 C) ∞ D) -1
- 287) $\lim_{x \rightarrow 3^+} \frac{2}{x^2 - 9}$ 287) _____
 A) $-\infty$ B) ∞ C) 0 D) 1
- 288) $\lim_{x \rightarrow 2^-} \frac{1}{x^2 - 4}$ 288) _____
 A) 1 B) 0 C) $-\infty$ D) ∞
- 289) $\lim_{x \rightarrow 0} \frac{1}{x^{2/3}}$ 289) _____
 A) 0 B) $-\infty$ C) $2/3$ D) ∞
- 290) $\lim_{x \rightarrow (\pi/2)^+} \tan x$ 290) _____
 A) ∞ B) $-\infty$ C) 1 D) 0
- 291) $\lim_{x \rightarrow (-\pi/2)^-} \sec x$ 291) _____
 A) 0 B) ∞ C) $-\infty$ D) 1
- 292) $\lim_{x \rightarrow 0^+} (1 + \csc x)$ 292) _____
 A) 0 B) 1 C) ∞ D) Does not exist
- 293) $\lim_{x \rightarrow 0} (1 - \cot x)$ 293) _____
 A) $-\infty$ B) ∞ C) 0 D) Does not exist
- 294) $\lim_{x \rightarrow 0^-} \frac{x^2}{3} - \frac{1}{x}$ 294) _____
 A) 0 B) ∞ C) Does not exist D) $-\infty$
- 295) $\lim_{x \rightarrow \sqrt[3]{6}} \frac{x^2}{6} - \frac{1}{x}$ 295) _____
 A) $-\infty$ B) 0 C) ∞ D) $2\sqrt[3]{6}$
- 296) $\lim_{x \rightarrow -3^+} \frac{x^2 - 5x + 6}{x^3 - 9x}$ 296) _____
 A) 0 B) ∞ C) Does not exist D) $-\infty$

297) $\lim_{x \rightarrow 0} \frac{x^2 - 8x + 15}{x^3 - 9x}$ 297) _____
 A) 15 B) $-\infty$ C) Does not exist D) ∞

298) $\lim_{x \rightarrow 0^+} \left(\frac{1}{x^{3/5}} + 7 \right)$ 298) _____
 A) 7 B) ∞ C) Does not exist D) $-\infty$

299) $\lim_{x \rightarrow 0^-} \left(\frac{1}{x^{2/5}} + 5 \right)$ 299) _____
 A) 5 B) Does not exist C) ∞ D) $-\infty$

300) $\lim_{x \rightarrow 1^+} \left(\frac{1}{x^{1/3}} - \frac{1}{(x-1)^{2/3}} \right)$ 300) _____
 A) 0 B) ∞ C) $-\infty$ D) Does not exist

301) $\lim_{x \rightarrow 3^-} \left(\frac{1}{x^{1/5}} - \frac{1}{(x-3)^{3/5}} \right)$ 301) _____
 A) $-\infty$ B) 0 C) Does not exist D) ∞

Graph the rational function. Include the graphs and equations of the asymptotes.

302) $f(x) = \frac{x}{x+2}$ 302) _____

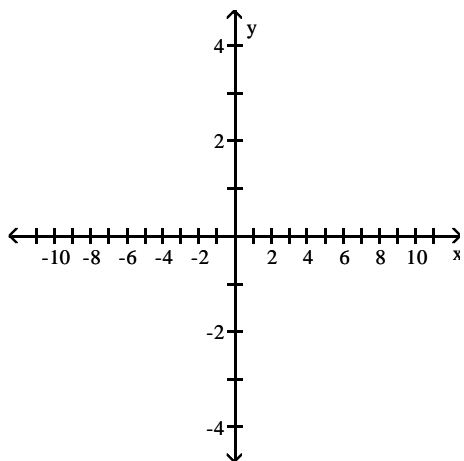

A) asymptotes: $x = -2, y = 1$

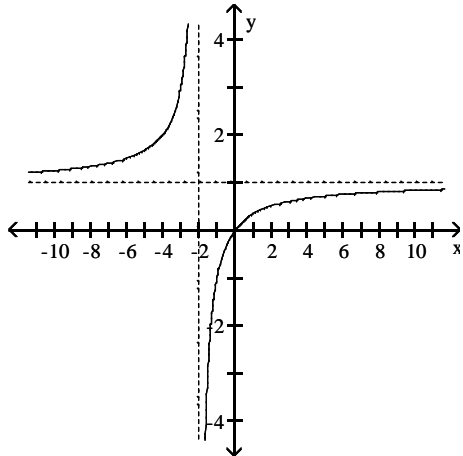

B) asymptotes: $x = 2, y = 0$

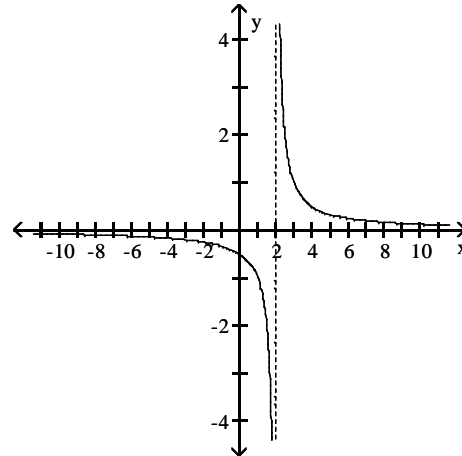

C) asymptotes: $x = 2, y = 1$

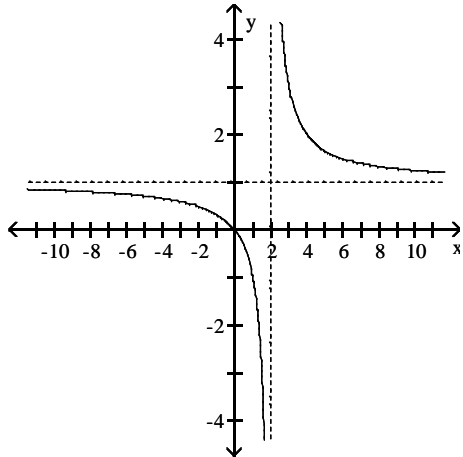

D) asymptotes: $x = -2, y = 0$

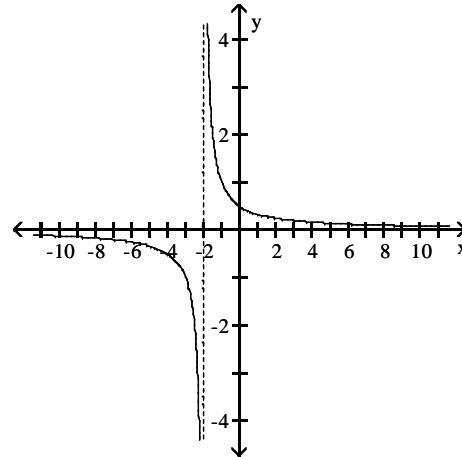

303) $f(x) = \frac{x}{x^2 + x + 4}$

303) _____

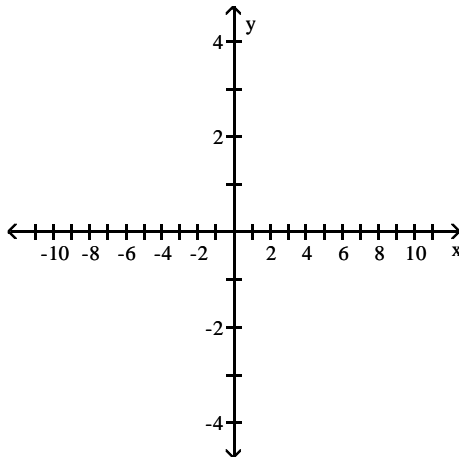

A) asymptotes: $x = 4, x = -4$

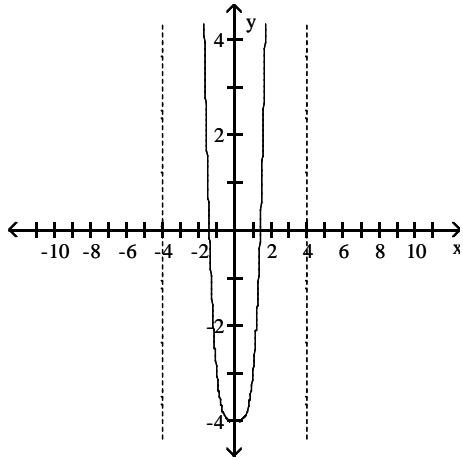

B) asymptote: $y = 0$

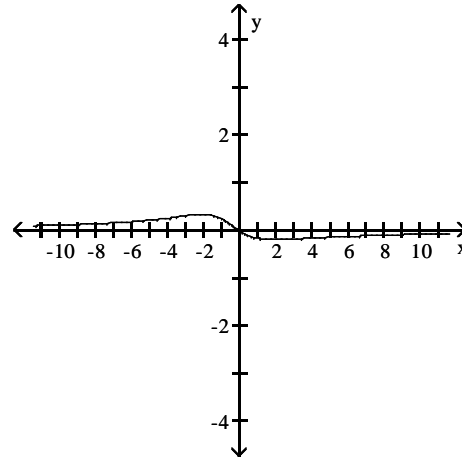

C) asymptote: $y = 1$

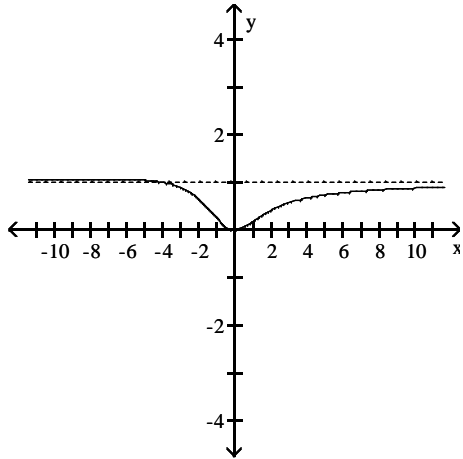

D) asymptote: $y = 0$

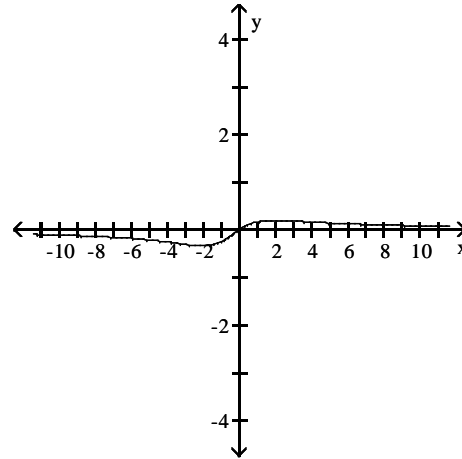

304) $f(x) = \frac{x^2 - 3}{x^3}$

304) _____

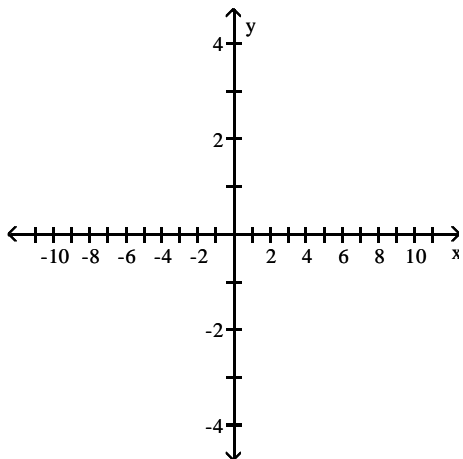

A) asymptotes: $x = 0, y = 0$

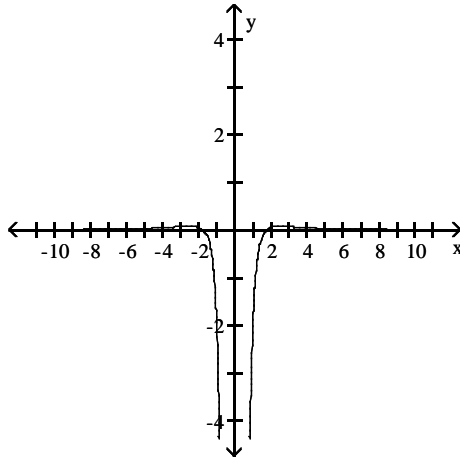

B) asymptotes: $x = 0, y = 0$

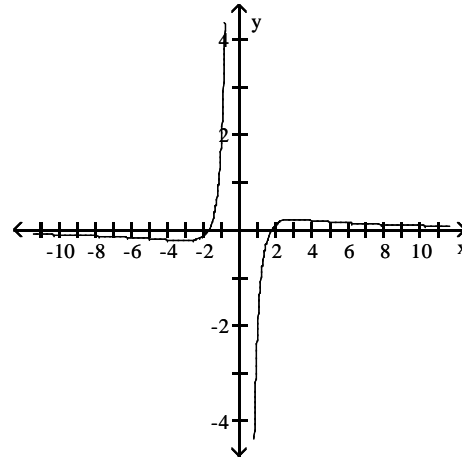

C) asymptote: $y = 0$

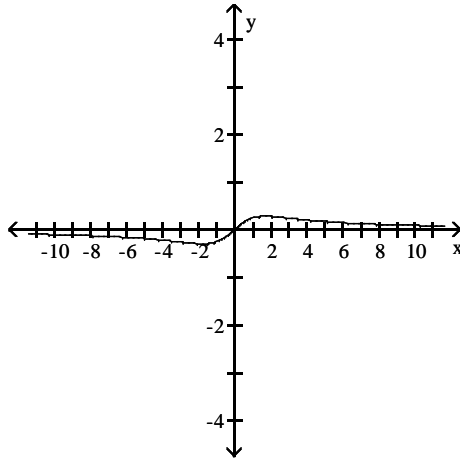

D) asymptotes: $x = 0, y = 0$

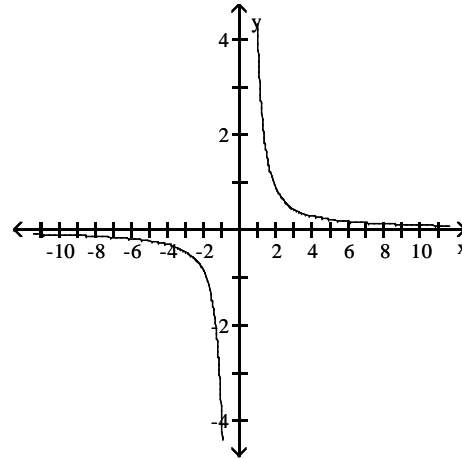

305) $f(x) = \frac{1}{x+1}$

305) _____

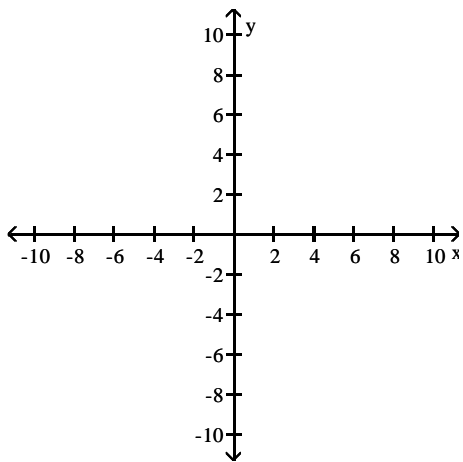

A) asymptotes: $x = 1, y = 0$

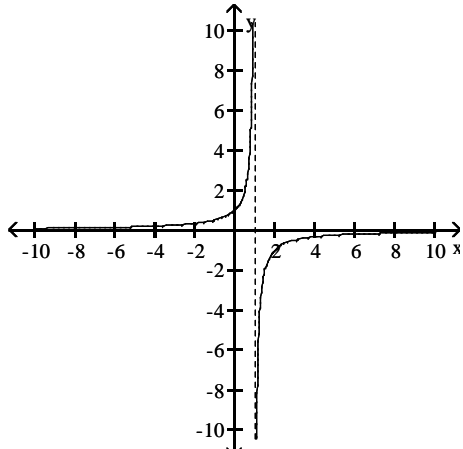

B) asymptotes: $x = -1, y = 0$

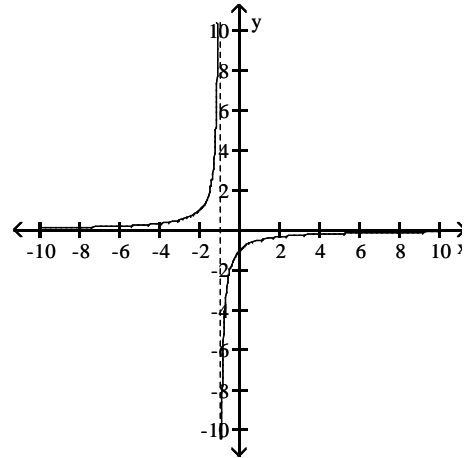

C) asymptotes: $x = 1, y = 0$

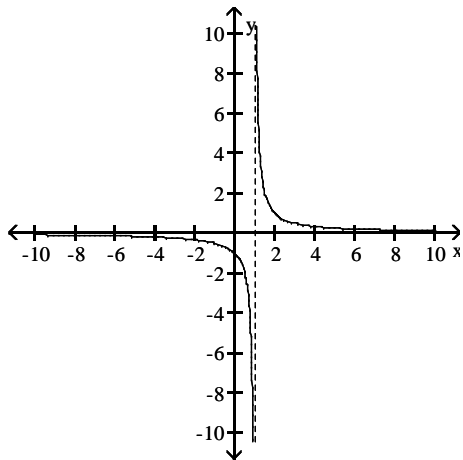

D) asymptotes: $x = -1, y = 0$

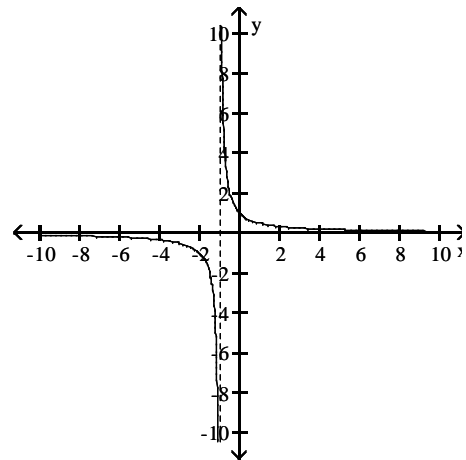

306) $f(x) = \frac{x - 1}{x + 1}$

306) _____

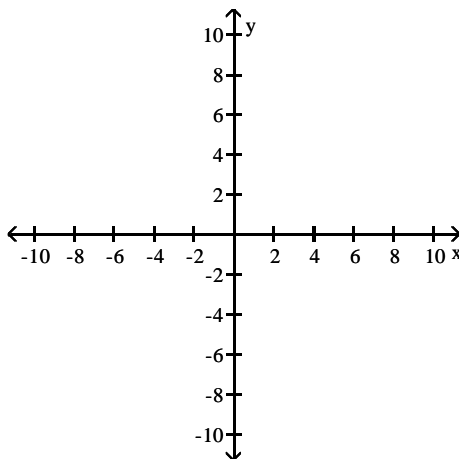

A) asymptotes: $x = -1, y = 1$

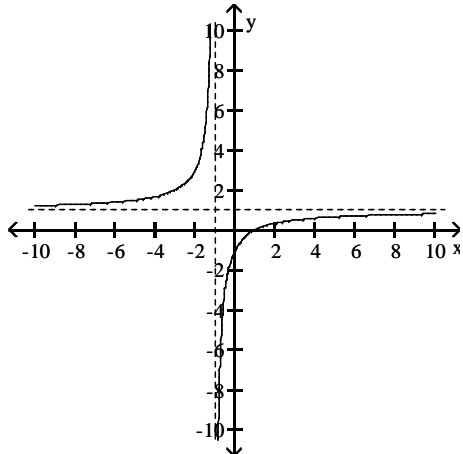

B) asymptotes: $x = -1, y = -1$

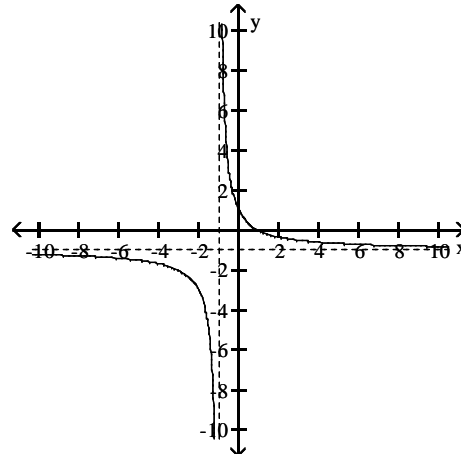

C) asymptotes: $x = 1, y = -1$

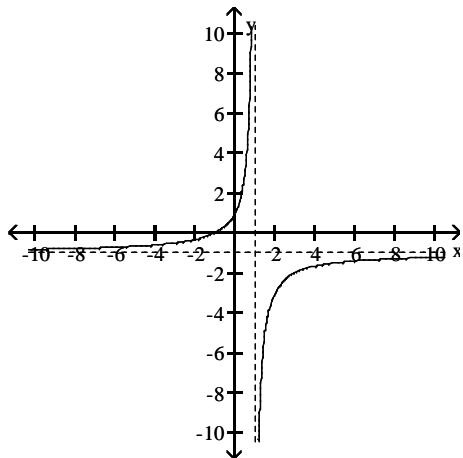

D) asymptotes: $x = 1, y = 1$

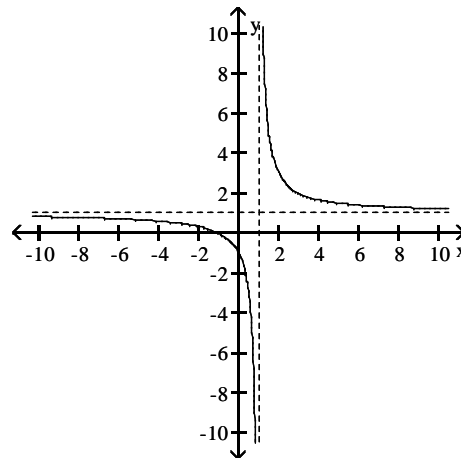

307) $f(x) = \frac{1}{(x+2)^2}$

307) _____

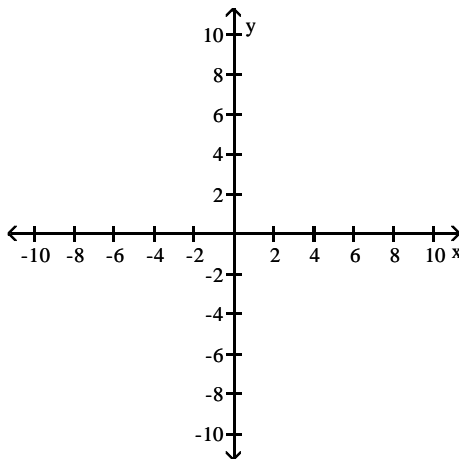

A) asymptotes: $x = -2, y = 0$

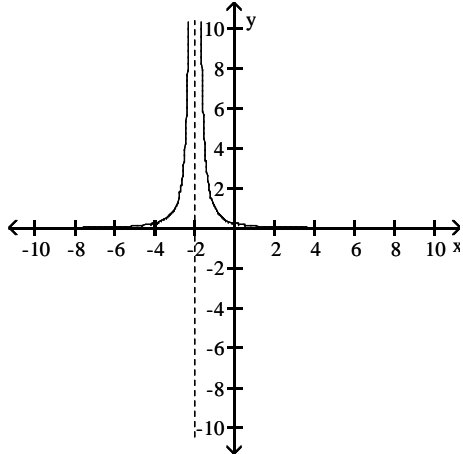

B) asymptotes: $x = 2, y = 0$

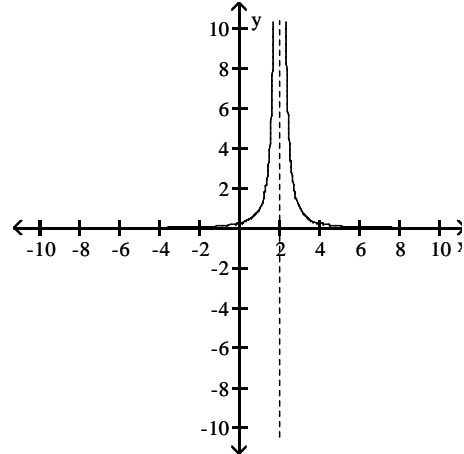

C) asymptotes: $x = -2, y = 0$

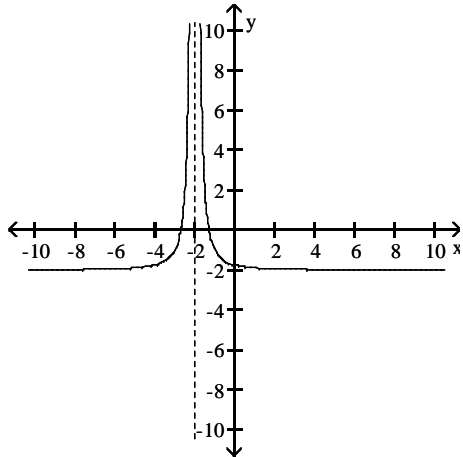

D) asymptotes: $x = 2, y = 0$

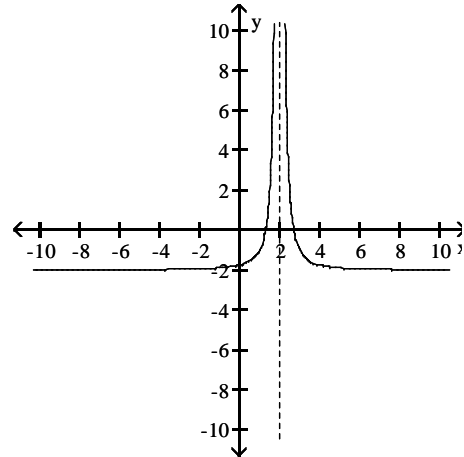

308) $f(x) = \frac{2x^2}{4 - x^2}$

308) _____

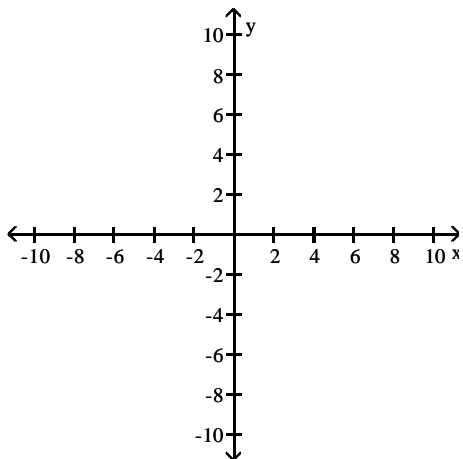

A) asymptotes: $x = -2, x = 2, y = 0$

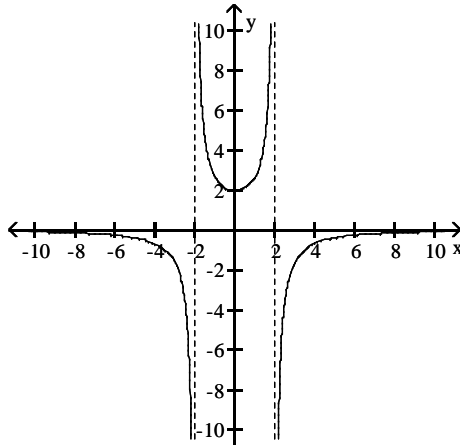

B) asymptotes: $x = -2, x = 2, y = -2$

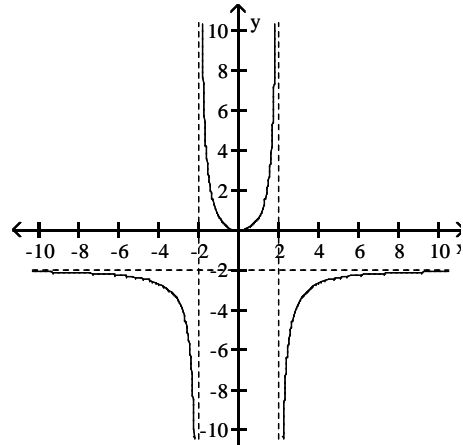

C) asymptotes: $x = -2, x = 2, y = 2$

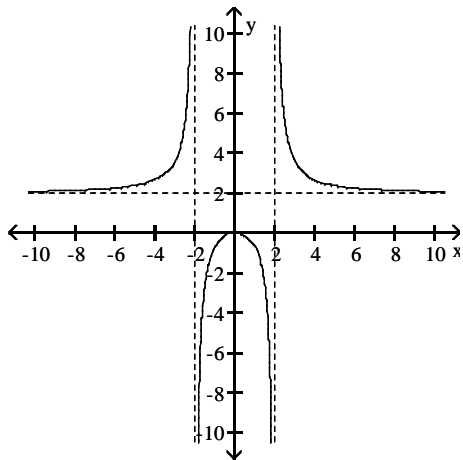

D) asymptotes: $x = -2, x = 2, y = 0$

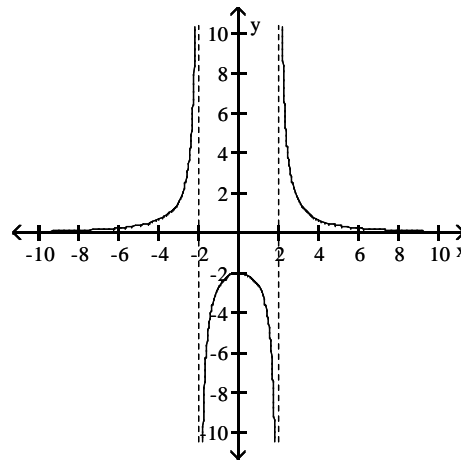

309) $f(x) = \frac{2 - x^2}{2x + 4}$

309) _____

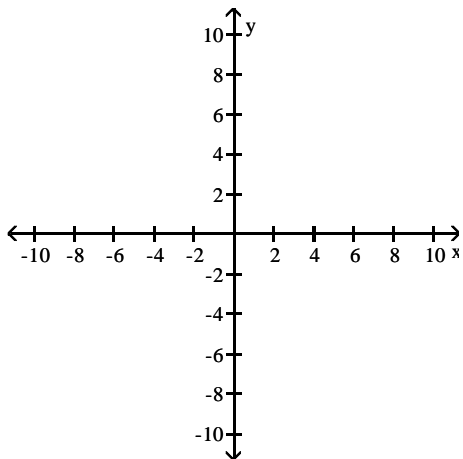

A) asymptotes: $x = -2$, $y = -\frac{1}{4}x + \frac{1}{2}$

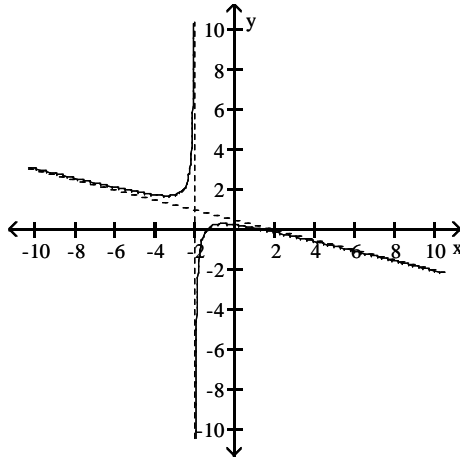

B) asymptotes: $x = -2$, $y = -\frac{1}{2}x + 1$

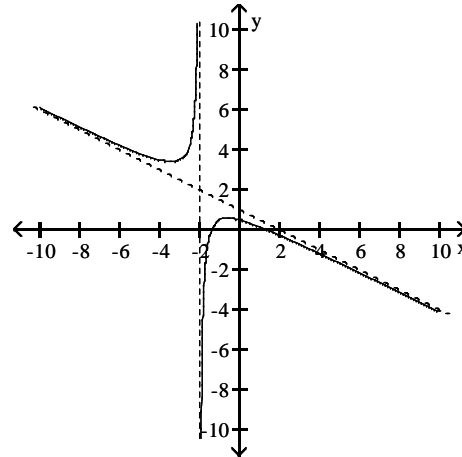

C) asymptotes: $x = -4$, $y = -\frac{1}{8}x + \frac{1}{2}$

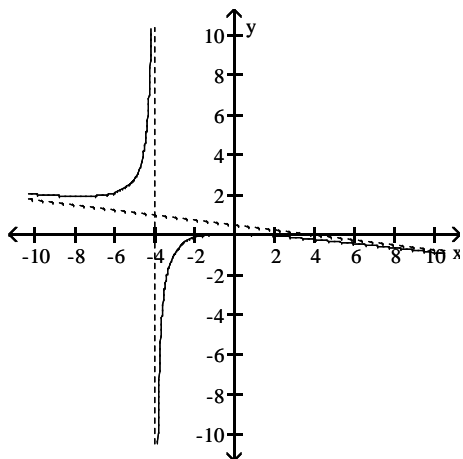

D) asymptotes: $x = -2$, $y = -x + 2$

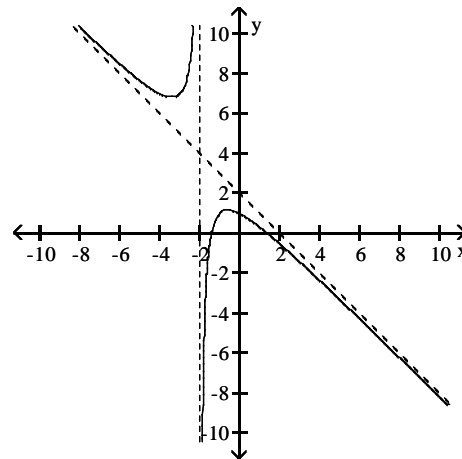

310) $f(x) = \frac{2 - 2x - x^2}{x}$

310) _____

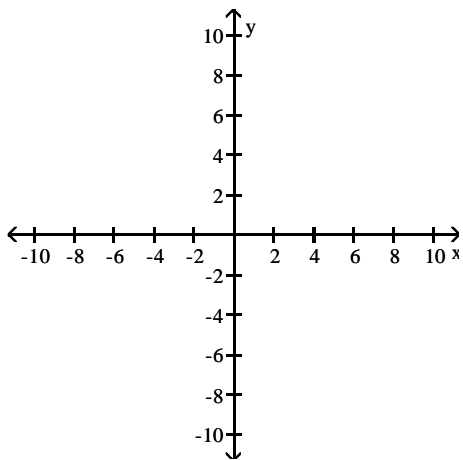

A) asymptotes: $x = 0, y = -x$

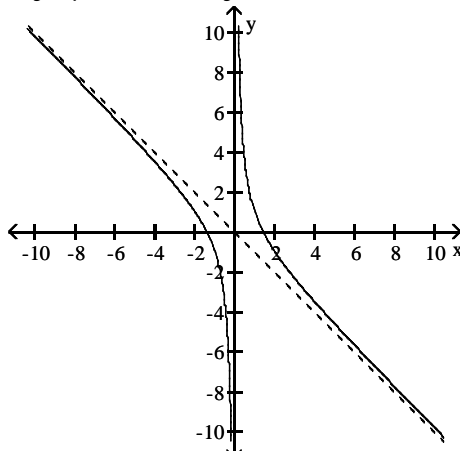

B) asymptotes: $x = 0, y = -x - 2$

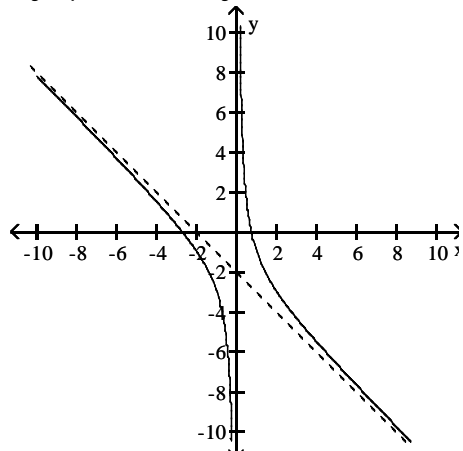

C) asymptotes: $x = 0, y = -x + 2$

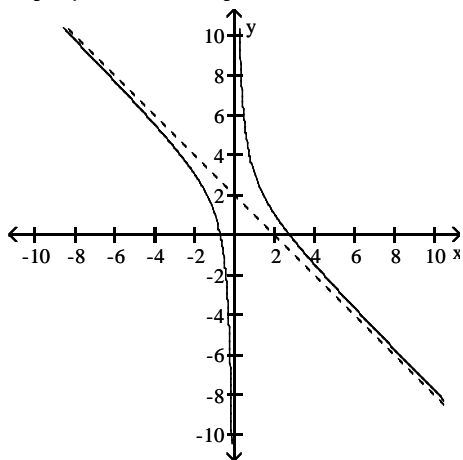

D) asymptotes: $x = 0, y = -x - 4$

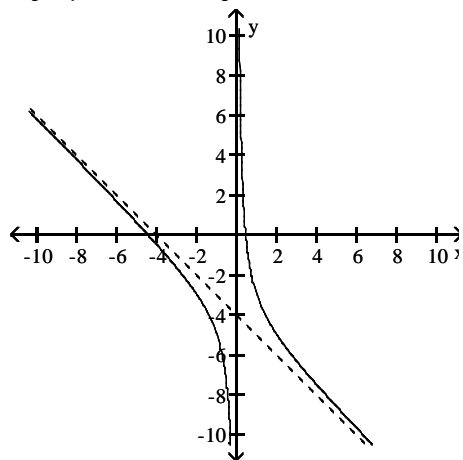

SHORT ANSWER. Write the word or phrase that best completes each statement or answers the question.

Sketch the graph of a function $y = f(x)$ that satisfies the given conditions.

311) $f(0) = 0, f(1) = 3, f(-1) = -3, \lim_{x \rightarrow -\infty} f(x) = -2, \lim_{x \rightarrow \infty} f(x) = 2.$

311) _____

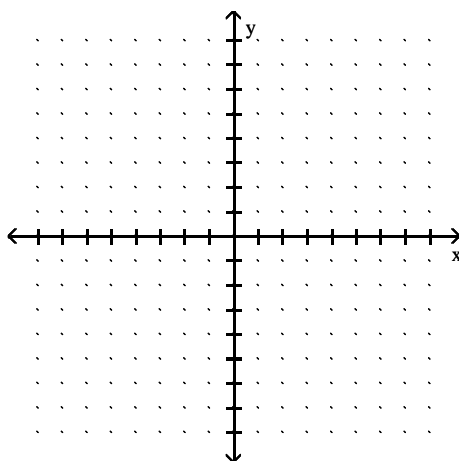

312) $f(0) = 0, f(1) = 3, f(-1) = 3, \lim_{x \rightarrow \pm\infty} f(x) = -3.$

312) _____

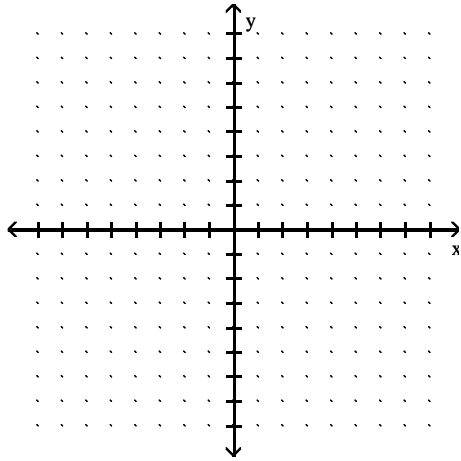

313) $f(0) = 3, f(1) = -3, f(-1) = -3, \lim_{x \rightarrow \pm\infty} f(x) = 0.$

313) _____

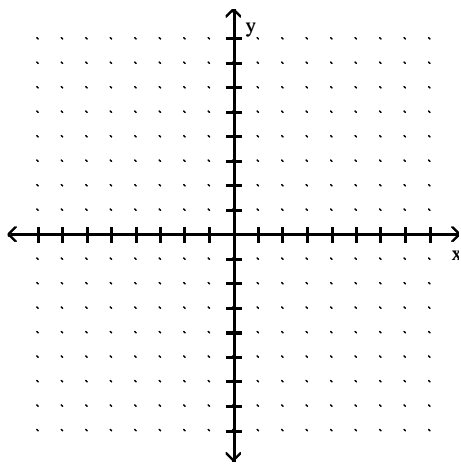

314) $f(0) = 0, \lim_{x \rightarrow \pm\infty} f(x) = 0, \lim_{x \rightarrow 4^-} f(x) = -\infty, \lim_{x \rightarrow -4^+} f(x) = -\infty, \lim_{x \rightarrow 4^+} f(x) = \infty, \lim_{x \rightarrow -4^-} f(x) = \infty.$

314) _____

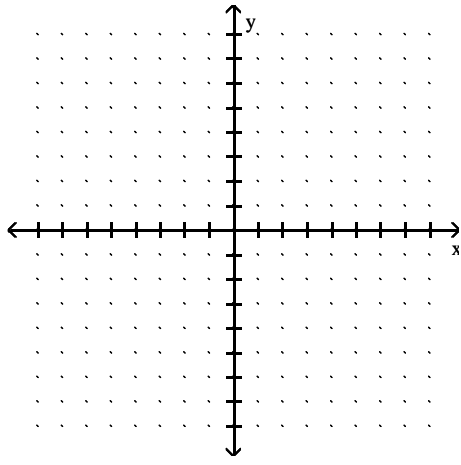

Find a function that satisfies the given conditions and sketch its graph.

315) $\lim_{x \rightarrow \pm\infty} f(x) = 0$, $\lim_{x \rightarrow 4^-} f(x) = \infty$, $\lim_{x \rightarrow 4^+} f(x) = \infty$.

315) _____

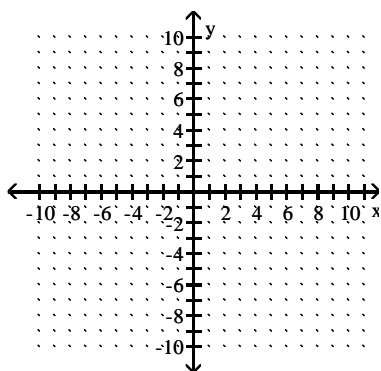

316) $\lim_{x \rightarrow \pm\infty} f(x) = 0$, $\lim_{x \rightarrow -4^-} f(x) = \infty$, $\lim_{x \rightarrow -4^+} f(x) = \infty$.

316) _____

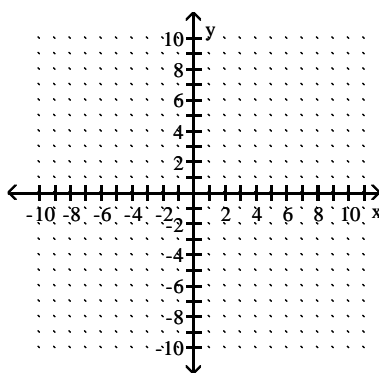

317) $\lim_{x \rightarrow -\infty} g(x) = -2$, $\lim_{x \rightarrow \infty} g(x) = 2$, $\lim_{x \rightarrow 0^+} g(x) = 2$, $\lim_{x \rightarrow 0^-} g(x) = -2$.

317) _____

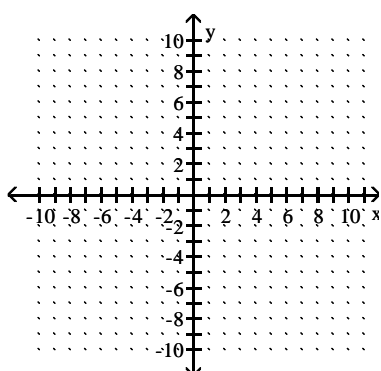

318) $\lim_{x \rightarrow \infty} f(x) = 0, \lim_{x \rightarrow 0^+} f(x) = \infty.$

318) _____

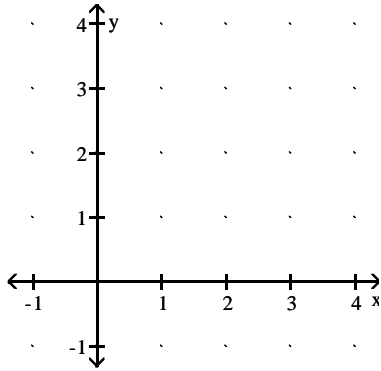

319) $\lim_{x \rightarrow -\infty} f(x) = 1, \lim_{x \rightarrow 0^+} f(x) = -1, \lim_{x \rightarrow \infty} f(x) = -1, \lim_{x \rightarrow 0^-} f(x) = 1$

319) _____

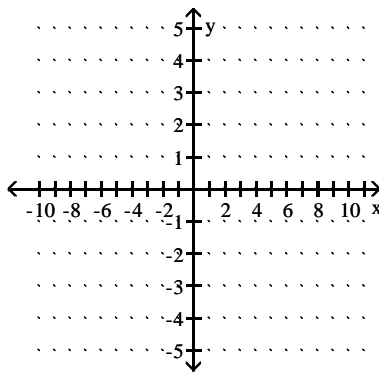

MULTIPLE CHOICE. Choose the one alternative that best completes the statement or answers the question.

Find the limit.

320) $\lim_{x \rightarrow \infty} (2x - \sqrt{4x^2 - 2x + 2})$ 320) _____

- A) 0 B) $\frac{1}{2}$ C) $-\infty$ D) -2

321) $\lim_{x \rightarrow \infty} \sqrt{x^2 + 10x} - x$ 321) _____

- A) ∞ B) 5 C) 10 D) 0

322) $\lim_{x \rightarrow \infty} (\sqrt{10x^2 + 3} - \sqrt{10x^2 - 3})$ 322) _____

- A) $\sqrt{10}$ B) 0 C) $\frac{1}{2\sqrt{10}}$ D) ∞

323) $\lim_{x \rightarrow \infty} \sqrt{x^2 + 5x} - \sqrt{x^2 - 3x}$ 323) _____

- A) 4 B) 8 C) does not exist D) 1

Provide an appropriate response.

324) Which of the following statements defines $\lim_{x \rightarrow x_0} f(x) = \infty$? 324) _____

- I. For every positive real number B there exists a corresponding $\delta > 0$ such that $f(x) > B$ whenever $x_0 - \delta < x < x_0 + \delta$.
 - II. For every positive real number B there exists a corresponding $\delta > 0$ such that $f(x) > B$ whenever $x_0 < x < x_0 + \delta$.
 - III. For every positive real number B there exists a corresponding $\delta > 0$ such that $f(x) > B$ whenever $x_0 - \delta < x < x_0$.
- A) I B) III C) I D) None

325) Which of the following statements defines $\lim_{x \rightarrow (x_0)^-} f(x) = \infty$? 325) _____

- I. For every positive real number B there exists a corresponding $\delta > 0$ such that $f(x) > B$ whenever $x_0 - \delta < x < x_0 + \delta$.
 - II. For every positive real number B there exists a corresponding $\delta > 0$ such that $f(x) > B$ whenever $x_0 < x < x_0 + \delta$.
 - III. For every positive real number B there exists a corresponding $\delta > 0$ such that $f(x) > B$ whenever $x_0 - \delta < x < x_0$.
- A) I B) III C) II D) None

326) Which of the following statements defines $\lim_{x \rightarrow (x_0)^+} f(x) = \infty$? 326) _____

- I. For every positive real number B there exists a corresponding $\delta > 0$ such that $f(x) > B$ whenever $x_0 - \delta < x < x_0 + \delta$.
 - II. For every positive real number B there exists a corresponding $\delta > 0$ such that $f(x) > B$ whenever $x_0 < x < x_0 + \delta$.
 - III. For every positive real number B there exists a corresponding $\delta > 0$ such that $f(x) > B$ whenever $x_0 - \delta < x < x_0$.
- A) I B) III C) II D) None

327) Which of the following statements defines $\lim_{x \rightarrow x_0} f(x) = -\infty$? 327) _____

- I. For every negative real number B there exists a corresponding $\delta > 0$ such that $f(x) < B$ whenever $x_0 - \delta < x < x_0 + \delta$.
 - II. For every negative real number B there exists a corresponding $\delta > 0$ such that $f(x) < B$ whenever $x_0 < x < x_0 + \delta$.
 - III. For every negative real number B there exists a corresponding $\delta > 0$ such that $f(x) < B$ whenever $x_0 - \delta < x < x_0$.
- A) II B) III C) I D) None

- 328) Which of the following statements defines $\lim_{x \rightarrow (x_0)^+} f(x) = -\infty$? 328) _____
- I. For every negative real number B there exists a corresponding $\delta > 0$ such that $f(x) < B$ whenever $x_0 - \delta < x < x_0 + \delta$.
- II. For every negative real number B there exists a corresponding $\delta > 0$ such that $f(x) < B$ whenever $x_0 < x < x_0 + \delta$.
- III. For every negative real number B there exists a corresponding $\delta > 0$ such that $f(x) < B$ whenever $x_0 - \delta < x < x_0$.
- A) I B) III C) II D) None

- 329) Which of the following statements defines $\lim_{x \rightarrow (x_0)^-} f(x) = -\infty$? 329) _____
- I. For every negative real number B there exists a corresponding $\delta > 0$ such that $f(x) < B$ whenever $x_0 - \delta < x < x_0 + \delta$.
- II. For every negative real number B there exists a corresponding $\delta > 0$ such that $f(x) < B$ whenever $x_0 < x < x_0 + \delta$.
- III. For every negative real number B there exists a corresponding $\delta > 0$ such that $f(x) < B$ whenever $x_0 - \delta < x < x_0$.
- A) III B) II C) I D) None

- 330) Which of the following statements defines $\lim_{x \rightarrow -\infty} f(x) = \infty$? 330) _____
- I. For every positive real number B there exists a corresponding positive real number N such that $f(x) > B$ whenever $x > N$.
- II. For every positive real number B there exists a corresponding negative real number N such that $f(x) > B$ whenever $x < N$.
- III. For every negative real number B there exists a corresponding negative real number N such that $f(x) < B$ whenever $x < N$.
- IV. For every negative real number B there exists a corresponding positive real number N such that $f(x) < B$ whenever $x > N$.
- A) I B) III C) IV D) II

SHORT ANSWER. Write the word or phrase that best completes each statement or answers the question.

- 331) Use the formal definitions of limits to prove $\lim_{x \rightarrow 0} \frac{4}{|x|} = \infty$ 331) _____

- 332) Use the formal definitions of limits to prove $\lim_{x \rightarrow 0^+} \frac{2}{x} = \infty$ 332) _____

Answer Key

Testname: UNTITLED2

- 1) C
- 2) D
- 3) C
- 4) D
- 5) D
- 6) B
- 7) A
- 8) D
- 9) D
- 10) D
- 11) C
- 12) C
- 13) D
- 14) B
- 15) A
- 16) A
- 17) D
- 18) D
- 19) C
- 20) C
- 21) C
- 22) C
- 23) B
- 24) C
- 25) D
- 26) A
- 27) D
- 28) A
- 29) C
- 30) B
- 31) B
- 32) D
- 33) C
- 34) D
- 35) D
- 36) C
- 37) B
- 38) A
- 39) C
- 40) C
- 41) D
- 42) B
- 43) C
- 44) A
- 45) D
- 46) C
- 47) B
- 48) A
- 49) D
- 50) D

Answer Key

Testname: UNTITLED2

- 51) D
- 52) C
- 53) C
- 54) B
- 55) B
- 56) A
- 57) D
- 58) D
- 59) D
- 60) C
- 61) C
- 62) A
- 63) A
- 64) B
- 65) B
- 66) D
- 67) B
- 68) C
- 69) B
- 70) D
- 71) B
- 72) C
- 73) B
- 74) C
- 75) D
- 76) D
- 77) A
- 78) C
- 79) B
- 80) B
- 81) C
- 82) B
- 83) D
- 84) D
- 85) B
- 86) C
- 87) A
- 88) D
- 89) B
- 90) B
- 91) D
- 92) B
- 93) C
- 94) A
- 95) D
- 96) A
- 97) D
- 98) B
- 99) B
- 100) A

Answer Key

Testname: UNTITLED2

- 101) B
- 102) D
- 103) B
- 104) B
- 105) D
- 106) D
- 107) B
- 108) D
- 109) C
- 110) C
- 111) A
- 112) B
- 113) C
- 114) C
- 115) B
- 116) A
- 117) D
- 118) C
- 119) D
- 120) A
- 121) D
- 122) D
- 123) C
- 124) D
- 125) D
- 126) B
- 127) A
- 128) D
- 129) A
- 130) D
- 131) A
- 132) B
- 133) D
- 134) A
- 135) B
- 136) C
- 137) C
- 138) D
- 139) A
- 140) D
- 141) D
- 142) C
- 143) A
- 144)

Let $\varepsilon > 0$ be given. Choose $\delta = \varepsilon/5$. Then $0 < |x - 2| < \delta$ implies that

$$\begin{aligned} |(5x - 3) - 7| &= |5x - 10| \\ &= |5(x - 2)| \\ &= 5|x - 2| < 5\delta = \varepsilon \end{aligned}$$

Thus, $0 < |x - 2| < \delta$ implies that $|(5x - 3) - 7| < \varepsilon$

Answer Key

Testname: UNTITLED2

145) Let $\varepsilon > 0$ be given. Choose $\delta = \varepsilon$. Then $0 < |x - 6| < \delta$ implies that

$$\begin{aligned} \left| \frac{x^2 - 36}{x - 6} - 12 \right| &= \left| \frac{(x - 6)(x + 6)}{x - 6} - 12 \right| \\ &= |(x + 6) - 12| \quad \text{for } x \neq 6 \\ &= |x - 6| < \delta = \varepsilon \end{aligned}$$

Thus, $0 < |x - 6| < \delta$ implies that $\left| \frac{x^2 - 36}{x - 6} - 12 \right| < \varepsilon$

146) Let $\varepsilon > 0$ be given. Choose $\delta = \varepsilon/3$. Then $0 < |x - 9| < \delta$ implies that

$$\begin{aligned} \left| \frac{3x^2 - 25x - 18}{x - 9} - 29 \right| &= \left| \frac{(x - 9)(3x + 2)}{x - 9} - 29 \right| \\ &= |(3x + 2) - 29| \quad \text{for } x \neq 9 \\ &= |3x - 27| \\ &= |3(x - 9)| \\ &= 3|x - 9| < 3\delta = \varepsilon \end{aligned}$$

Thus, $0 < |x - 9| < \delta$ implies that $\left| \frac{3x^2 - 25x - 18}{x - 9} - 29 \right| < \varepsilon$

147) Let $\varepsilon > 0$ be given. Choose $\delta = \min\{3/2, 9\varepsilon/2\}$. Then $0 < |x - 3| < \delta$ implies that

$$\begin{aligned} \left| \frac{1}{x} - \frac{1}{3} \right| &= \left| \frac{3 - x}{3x} \right| \\ &= \frac{1}{|x|} \cdot \frac{1}{3} \cdot |x - 3| \\ &< \frac{1}{3/2} \cdot \frac{1}{3} \cdot \frac{9\varepsilon}{2} = \varepsilon \end{aligned}$$

Thus, $0 < |x - 3| < \delta$ implies that $\left| \frac{1}{x} - \frac{1}{3} \right| < \varepsilon$

148) C

149) C

150) D

151) D

152) B

153) B

154) A

155) D

156) B

157) C

158) D

159) D

160) C

161) D

162) D

163) A

164) D

165) C

166) C

167) A

168) C

169) B

Answer Key

Testname: UNTITLED2

- 170) C
- 171) D
- 172) D
- 173) B
- 174) A
- 175) D
- 176) B
- 177) C
- 178) D
- 179) D
- 180) D
- 181) A
- 182) D
- 183) A
- 184) B
- 185) C
- 186) B
- 187) C
- 188) D
- 189) B
- 190) C
- 191) B
- 192) B
- 193) B
- 194) B
- 195) D
- 196) B
- 197) B
- 198) C
- 199) D
- 200) D
- 201) A
- 202) A
- 203) A
- 204) B
- 205) A
- 206) A
- 207) B
- 208) B
- 209) B
- 210) A
- 211) B
- 212) B
- 213) A
- 214) A
- 215) B
- 216) B
- 217) B
- 218) D
- 219) A

Answer Key

Testname: UNTITLED2

- 220) D
- 221) B
- 222) A
- 223) D
- 224) C
- 225) A
- 226) C
- 227) C
- 228) C
- 229) D
- 230) D
- 231) B
- 232) B
- 233) A
- 234) A
- 235) B
- 236) D
- 237) B
- 238) C
- 239) B
- 240) C
- 241) A
- 242) B

243) Let $f(x) = 4x^3 + 9x^2 + 2x + 8$ and let $y_0 = 0$. $f(-3) = -25$ and $f(-2) = 8$. Since f is continuous on $[-3, -2]$ and since $y_0 = 0$ is between $f(-3)$ and $f(-2)$, by the Intermediate Value Theorem, there exists a c in the interval $(-3, -2)$ with the property that $f(c) = 0$. Such a c is a solution to the equation $4x^3 + 9x^2 + 2x + 8 = 0$.

244) Let $f(x) = -9x^4 + 10x^3 - 6x + 7$ and let $y_0 = 0$. $f(1) = 2$ and $f(2) = -69$. Since f is continuous on $[1, 2]$ and since $y_0 = 0$ is between $f(1)$ and $f(2)$, by the Intermediate Value Theorem, there exists a c in the interval $(1, 2)$ with the property that $f(c) = 0$. Such a c is a solution to the equation $-9x^4 + 10x^3 - 6x + 7 = 0$.

245) Let $f(x) = x(x - 3)^2$ and let $y_0 = 3$. $f(2) = 2$ and $f(4) = 4$. Since f is continuous on $[2, 4]$ and since $y_0 = 3$ is between $f(2)$ and $f(4)$, by the Intermediate Value Theorem, there exists a c in the interval $(2, 4)$ with the property that $f(c) = 3$. Such a c is a solution to the equation $x(x - 3)^2 = 3$.

246) Let $f(x) = \frac{\sin x}{x}$ and let $y_0 = \frac{1}{5}$. $f\left(\frac{\pi}{2}\right) \approx 0.6366$ and $f(\pi) = 0$. Since f is continuous on $\left[\frac{\pi}{2}, \pi\right]$ and since $y_0 = \frac{1}{5}$ is between $f\left(\frac{\pi}{2}\right)$ and $f(\pi)$, by the Intermediate Value Theorem, there exists a c in the interval $\left(\frac{\pi}{2}, \pi\right)$, with the property that $f(c) = \frac{1}{5}$. Such a c is a solution to the equation $5 \sin x = x$.

- 247) D
- 248) A

Answer Key

Testname: UNTITLED2

249) The Intermediate Value Theorem implies that there is at least one solution to $f(x) = 0$ on the interval $[-3, 1]$.

Possible graph:

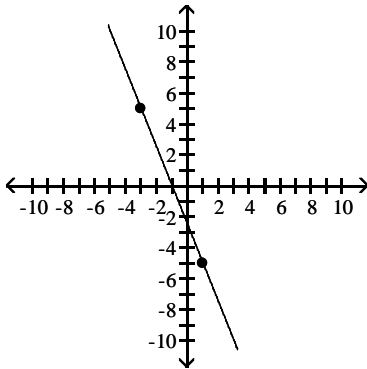

250) The roots of $f(x)$ are the solutions to the equation $f(x) = 0$. Statement (b) is asking for the solution to the equation $3x^3 = 3x + 4$. Statement (d) is asking for the solution to the equation $3x^3 - 3x = 4$. These three equations are equivalent to the equations in statements (c) and (e). As five equations are equivalent, their solutions are the same.

251) Notice that $f(0) = 5$ and $f(1) = 2$. As f is continuous on $[0,1]$, the Intermediate Value Theorem implies that there is a number c such that $f(c) = \pi$.

252) Yes, if $f(x) = 1$ and $g(x) = x - 4$, then $h(x) = \frac{1}{x - 4}$ is discontinuous at $x = 4$.

253) Let $f(x) = \frac{\sin(x - 2)}{(x - 2)}$ be defined for all $x \neq 2$. The function f is continuous for all $x \neq 2$. The function is not defined at $x = 2$ because division by zero is undefined; hence f is not continuous at $x = 2$. This discontinuity is removable because $\lim_{x \rightarrow 2} \frac{\sin(x - 2)}{x - 2} = 1$. (We can extend the function to $x = 2$ by defining its value to be 1.)

254) Let $f(x) = \frac{1}{(x - 7)^2}$, for all $x \neq 7$. The function f is continuous for all $x \neq 7$, and $\lim_{x \rightarrow 7} \frac{1}{(x - 7)^2} = \infty$. As f is unbounded as x approaches 7, f is discontinuous at $x = 7$, and, moreover, this discontinuity is nonremovable.

- 255) A
- 256) C
- 257) D
- 258) C
- 259) A
- 260) C
- 261) C
- 262) C
- 263) A
- 264) B
- 265) D
- 266) D
- 267) C
- 268) C
- 269) A
- 270) B
- 271) C
- 272) D
- 273) D

Answer Key

Testname: UNTITLED2

- 274) D
- 275) C
- 276) C
- 277) B
- 278) D
- 279) C
- 280) B
- 281) D
- 282) C
- 283) A
- 284) C
- 285) A
- 286) C
- 287) B
- 288) C
- 289) D
- 290) B
- 291) B
- 292) C
- 293) D
- 294) B
- 295) B
- 296) B
- 297) C
- 298) B
- 299) C
- 300) C
- 301) D
- 302) A
- 303) D
- 304) B
- 305) D
- 306) A
- 307) A
- 308) B
- 309) B
- 310) B

Answer Key

Testname: UNTITLED2

311) Answers may vary. One possible answer:

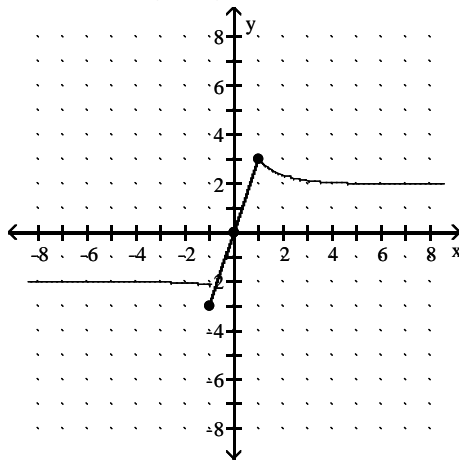

312) Answers may vary. One possible answer:

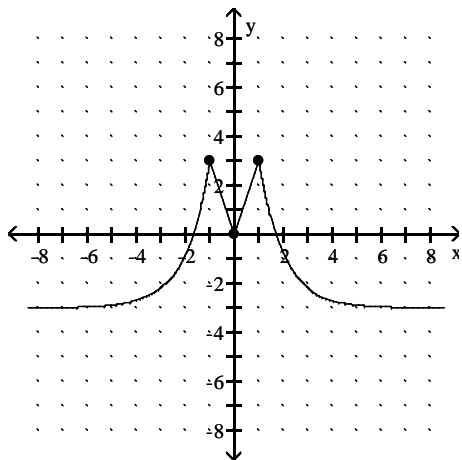

313) Answers may vary. One possible answer:

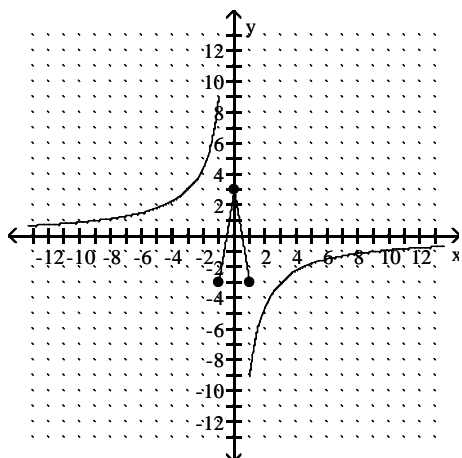

Answer Key

Testname: UNTITLED2

314) Answers may vary. One possible answer:

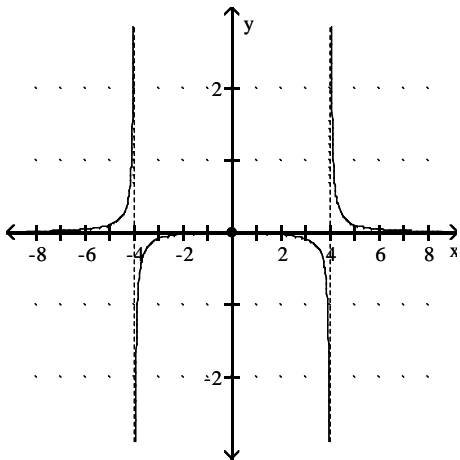

315) (Answers may vary.) Possible answer: $f(x) = \frac{1}{|x - 4|}$.

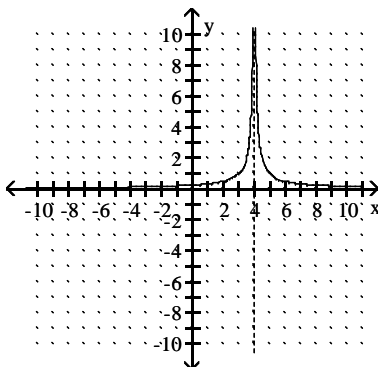

316) (Answers may vary.) Possible answer: $f(x) = \frac{1}{|x + 4|}$.

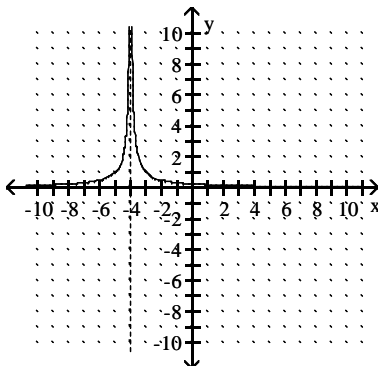

Answer Key

Testname: UNTITLED2

317) (Answers may vary.) Possible answer: $f(x) = \begin{cases} 2, & x > 0 \\ -2, & x < 0 \end{cases}$

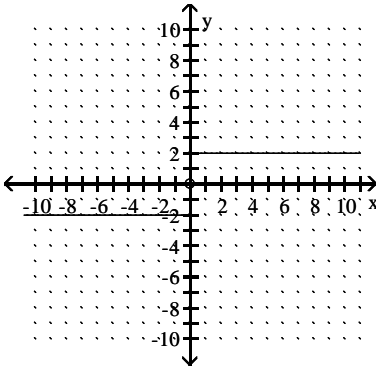

318) (Answers may vary.) Possible answer: $f(x) = \frac{1}{\sqrt{x}}$.

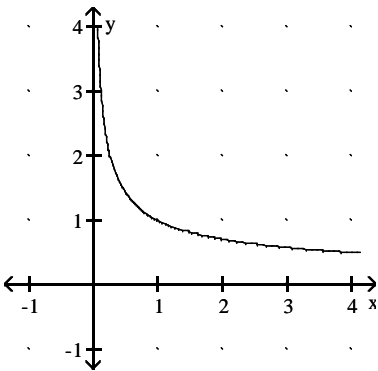

319) (Answers may vary.) Possible answer: $f(x) = \begin{cases} 1, & x < 0 \\ -1, & x > 0 \end{cases}$

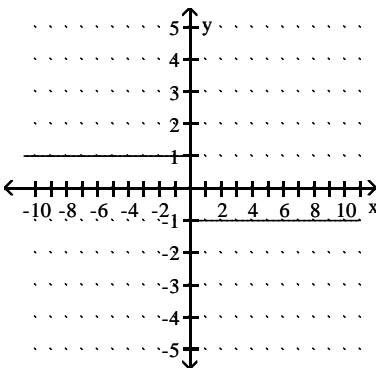

- 320) B
- 321) B
- 322) B
- 323) A
- 324) C
- 325) B
- 326) C
- 327) C
- 328) C
- 329) A
- 330) D

Answer Key

Testname: UNTITLED2

331) Given $B > 0$, we want to find $\delta > 0$ such that $0 < |x - 0| < \delta$ implies $\frac{4}{|x|} > B$.

Now, $\frac{4}{|x|} > B$ if and only if $|x| < \frac{4}{B}$.

Thus, choosing $\delta = 4/B$ (or any smaller positive number), we see that

$|x| < \delta$ implies $\frac{4}{|x|} > \frac{4}{|\delta|} \geq B$.

Therefore, by definition $\lim_{x \rightarrow 0} \frac{4}{|x|} = \infty$

332) Given $B > 0$, we want to find $\delta > 0$ such that $x_0 < x < x_0 + \delta$ implies $\frac{2}{x} > B$.

Now, $\frac{2}{x} > B$ if and only if $x < \frac{2}{B}$.

We know $x_0 = 0$. Thus, choosing $\delta = 2/B$ (or any smaller positive number), we see that

$x < \delta$ implies $\frac{2}{x} > \frac{2}{\delta} \geq B$.

Therefore, by definition $\lim_{x \rightarrow 0^+} \frac{2}{x} = \infty$