

TEST BANK

**COLLEGE
ALGEBRA**

Enhanced with Graphing Utilities, 5e

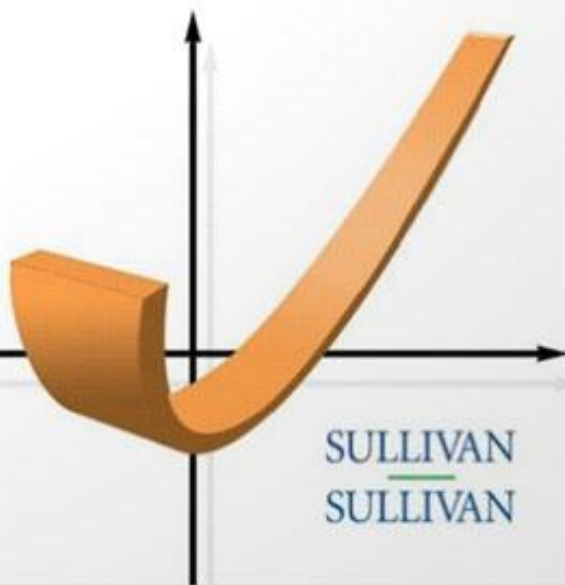

SULLIVAN
SULLIVAN



Ch. 2 Graphs

2.1 Intercepts; Symmetry; Graphing Key Equations

1 Find Intercepts Algebraically from an Equation

MULTIPLE CHOICE. Choose the one alternative that best completes the statement or answers the question.

List the intercepts for the graph of the equation.

1) $y = x - 4$

A) (4, 0), (0, -4)

B) (-4, 0), (0, 4)

C) (4, 0), (0, 4)

D) (-4, 0), (0, -4)

2) $y = 3x$

A) (0, 0)

B) (0, 3)

C) (3, 0)

D) (3, 3)

3) $y^2 = x + 81$

A) (0, -9), (-81, 0), (0, 9)

B) (-9, 0), (0, -81), (9, 0)

C) (0, -9), (81, 0), (0, 9)

D) (9, 0), (0, 81), (0, -81)

4) $y = \sqrt[3]{x}$

A) (0, 0)

B) (1, 0)

C) (0, 1)

D) (1, 1)

5) $x^2 + y - 36 = 0$

A) (-6, 0), (0, 36), (6, 0)

B) (-6, 0), (0, -36), (6, 0)

C) (0, -6), (36, 0), (0, 6)

D) (6, 0), (0, 36), (0, -36)

6) $4x^2 + 16y^2 = 64$

A) (-4, 0), (0, -2), (0, 2), (4, 0)

B) (-2, 0), (-4, 0), (4, 0), (2, 0)

C) (-16, 0), (0, -4), (0, 4), (16, 0)

D) (-4, 0), (-16, 0), (16, 0), (4, 0)

7) $16x^2 + y^2 = 16$

A) (-1, 0), (0, -4), (0, 4), (1, 0)

B) (-1, 0), (0, -16), (0, 16), (1, 0)

C) (-4, 0), (0, -1), (0, 1), (4, 0)

D) (-16, 0), (0, -1), (0, 1), (16, 0)

8) $y = x^3 - 8$

A) (0, -8), (2, 0)

B) (-8, 0), (0, 2)

C) (0, -2), (0, 2)

D) (0, -2), (-2, 0)

9) $y = x^4 - 1$

A) (0, -1), (-1, 0), (1, 0)

B) (0, -1)

C) (0, 1), (-1, 0), (1, 0)

D) (0, 1)

10) $y = x^2 + 12x + 32$

A) (-8, 0), (-4, 0), (0, 32)

B) (8, 0), (4, 0), (0, 32)

C) (0, -8), (0, -4), (32, 0)

D) (0, 8), (0, 4), (32, 0)

11) $y = x^2 + 16$

A) (0, 16)

C) (16, 0), (0, -4), (0, 4)

B) (0, 16), (-4, 0), (4, 0)

D) (16, 0)

12) $y = \frac{7x}{x^2 + 49}$

A) (0, 0)

C) (-49, 0), (0, 0), (49, 0)

B) (-7, 0), (0, 0), (7, 0)

D) (0, -7), (0, 0), (0, 7)

13) $y = \frac{x^2 - 25}{5x^4}$

A) (-5, 0), (5, 0)

C) (-25, 0), (0, 0), (25, 0)

B) (0, 0)

D) (0, -5), (0, 5)

2 Test an Equation for Symmetry with Respect to (a) the x -Axis, (b) the y -Axis, and (c) the Origin

MULTIPLE CHOICE. Choose the one alternative that best completes the statement or answers the question.

Plot the point A. Plot the point B that has the given symmetry with point A.

1) $A = (-3, 4)$; B is symmetric to A with respect to the y -axis

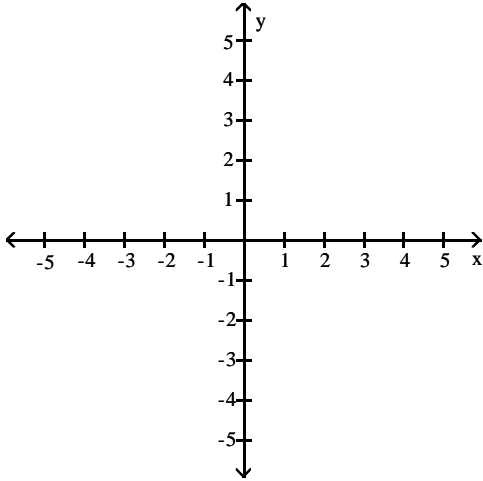

A)

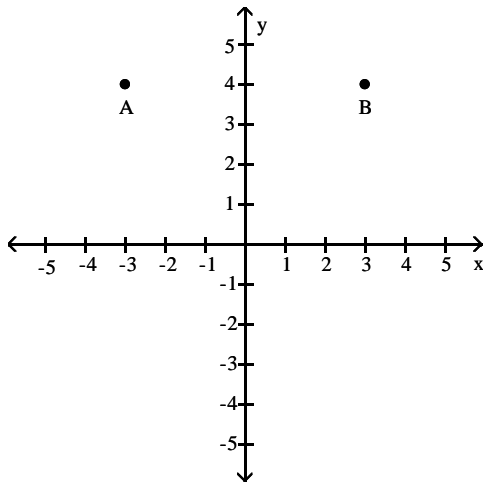

B)

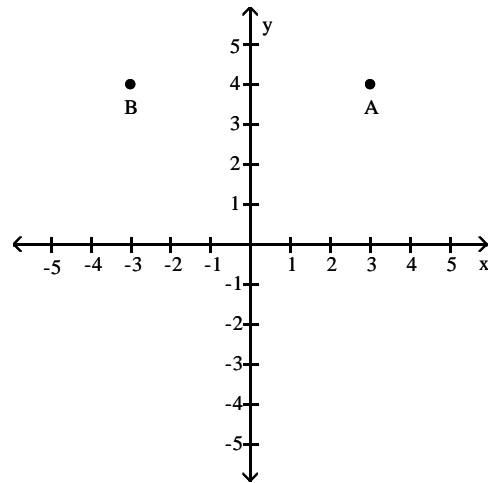

C)

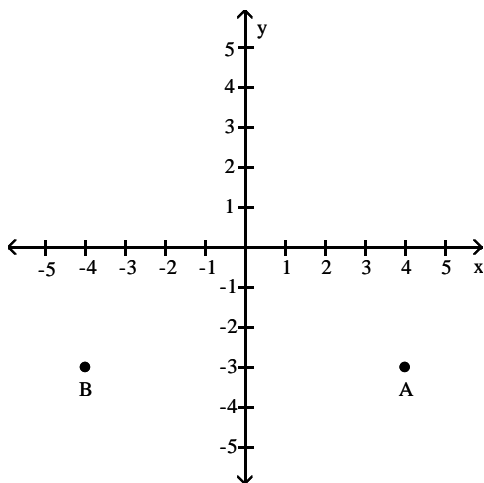

D)

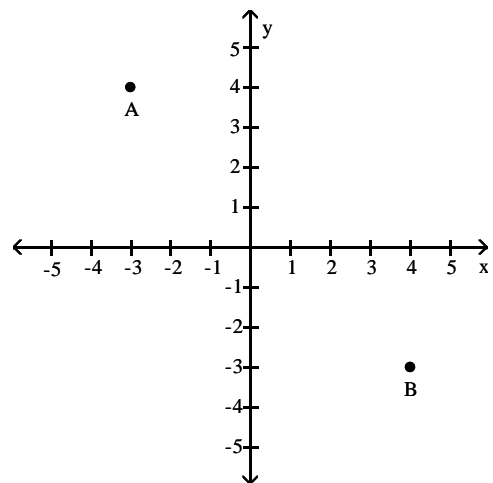

2) $A = (0, 3)$; B is symmetric to A with respect to the origin

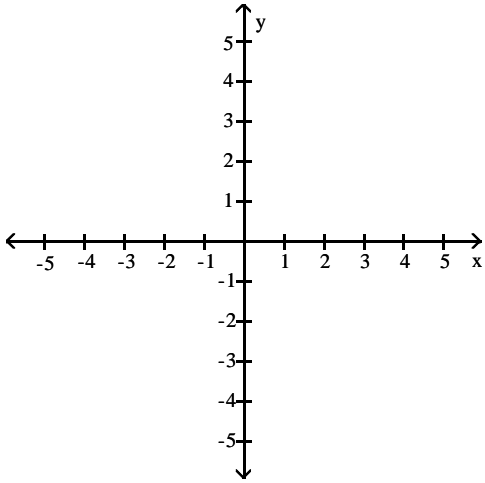

A)

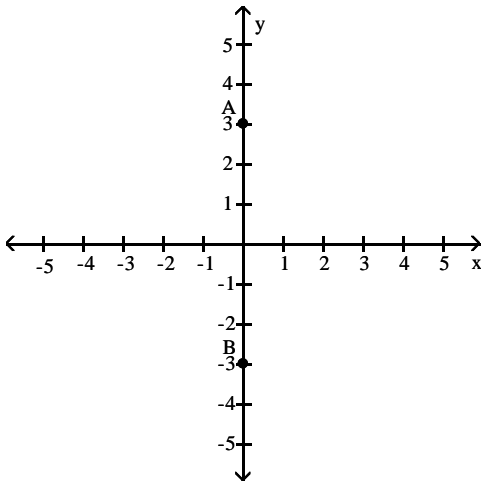

B)

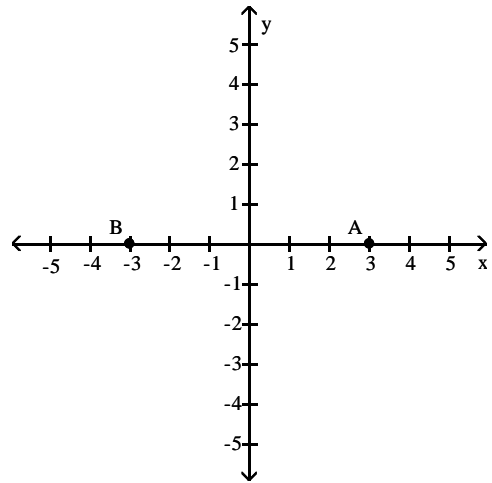

C)

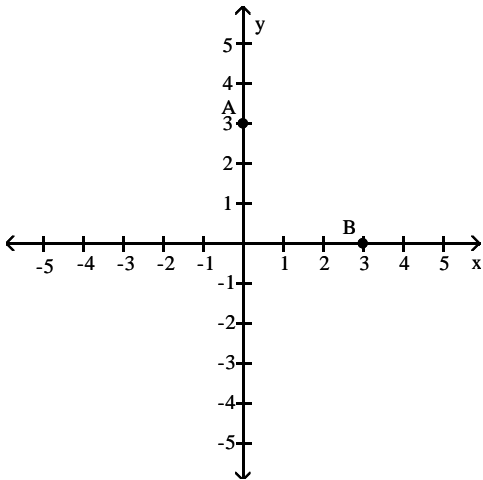

D)

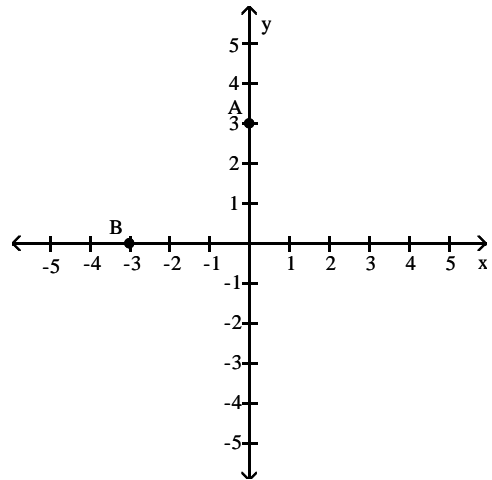

List the intercepts of the graph. Tell whether the graph is symmetric with respect to the x -axis, y -axis, origin, or none of these.

3)

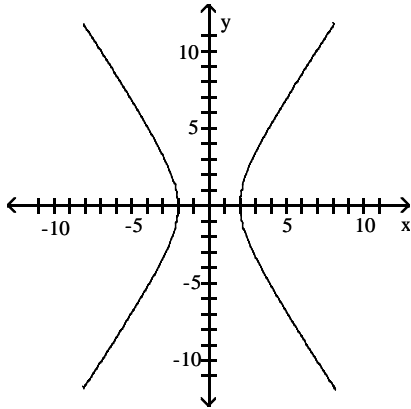

- A) intercepts: $(-2, 0)$ and $(2, 0)$
symmetric with respect to x -axis, y -axis, and origin
- B) intercepts: $(-2, 0)$ and $(2, 0)$
symmetric with respect to origin
- C) intercepts: $(0, -2)$ and $(0, 2)$
symmetric with respect to x -axis, y -axis, and origin
- D) intercepts: $(0, -2)$ and $(0, 2)$
symmetric with respect to y -axis

4)

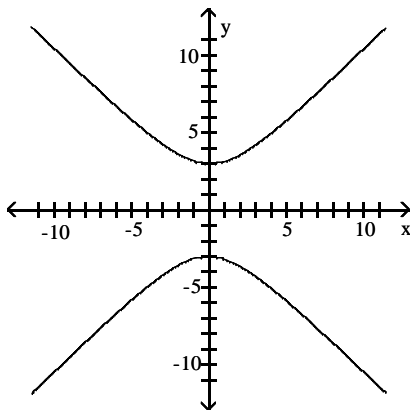

- A) intercepts: $(0, 3)$ and $(0, -3)$
symmetric with respect to x -axis, y -axis, and origin
- B) intercepts: $(0, 3)$ and $(0, -3)$
symmetric with respect to origin
- C) intercepts: $(3, 0)$ and $(-3, 0)$
symmetric with respect to x -axis, y -axis, and origin
- D) intercepts: $(3, 0)$ and $(-3, 0)$
symmetric with respect to y -axis

5)

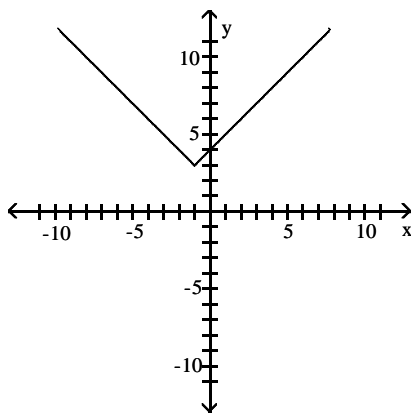

A) intercept: (0, 4)
no symmetry

C) intercept: (0, 4)
symmetric with respect to x-axis

B) intercept: (4, 0)
no symmetry

D) intercept: (4, 0)
symmetric with respect to y-axis

6)

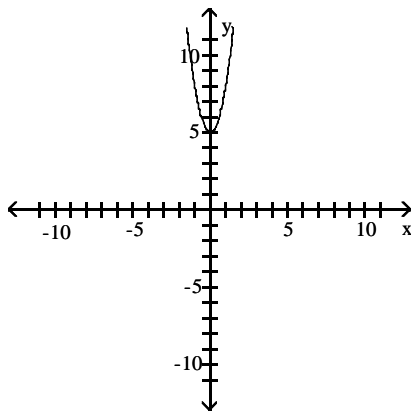

A) intercept: (0, 5)
symmetric with respect to y-axis

C) intercept: (5, 0)
symmetric with respect to y-axis

B) intercept: (0, 5)
symmetric with respect to origin

D) intercept: (5, 0)
symmetric with respect to x-axis

7)

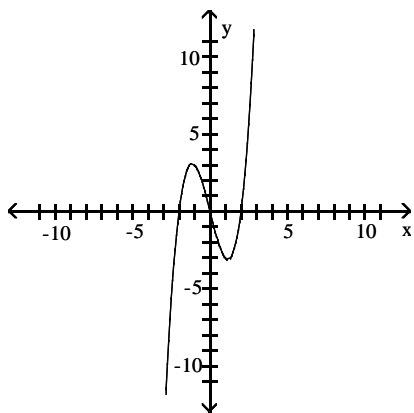

- A) intercepts: $(-2, 0)$, $(0, 0)$, $(2, 0)$
symmetric with respect to origin
- B) intercepts: $(-2, 0)$, $(0, 0)$, $(2, 0)$
symmetric with respect to x-axis
- C) intercepts: $(-2, 0)$, $(0, 0)$, $(2, 0)$
symmetric with respect to y-axis
- D) intercepts: $(-2, 0)$, $(0, 0)$, $(2, 0)$
symmetric with respect to x-axis, y-axis, and origin

Draw a complete graph so that it has the given type of symmetry.

8) Symmetric with respect to the y-axis

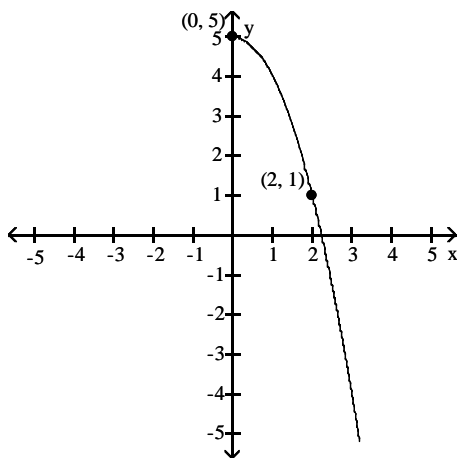

A)

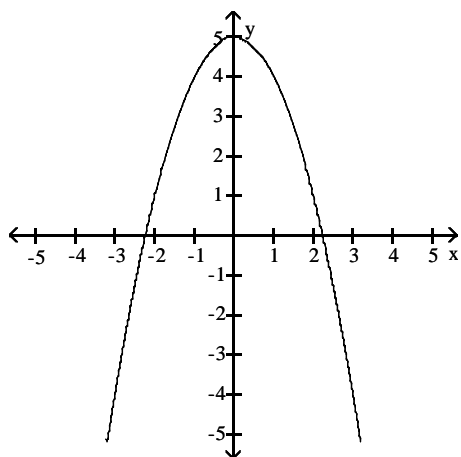

B)

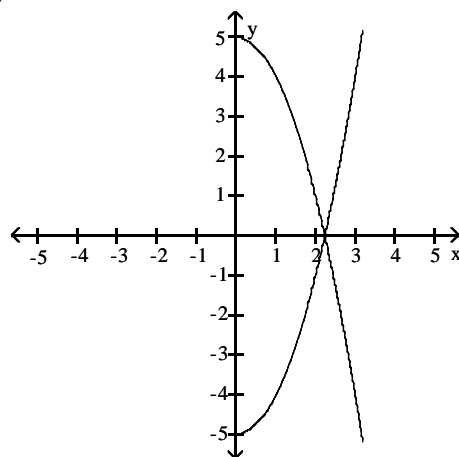

C)

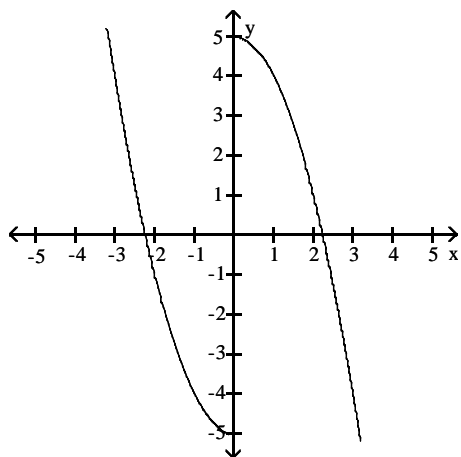

D)

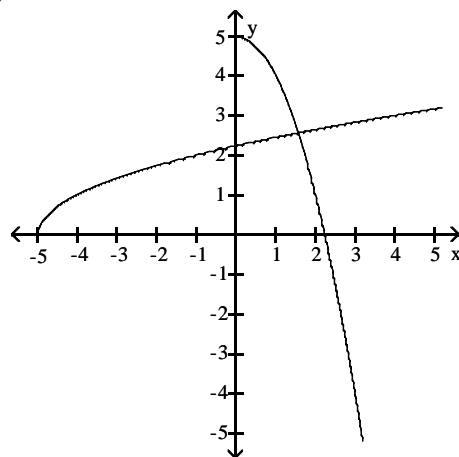

9) origin

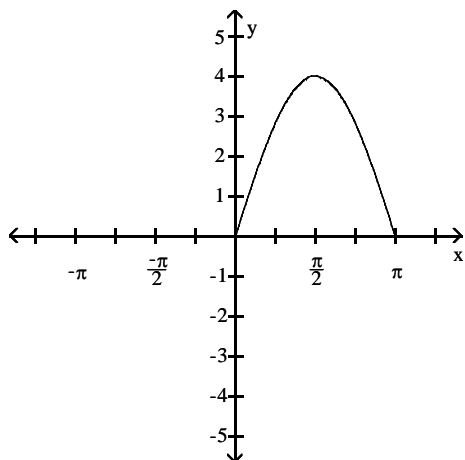

A)

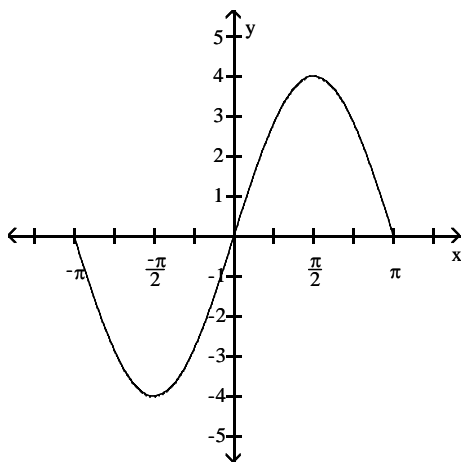

B)

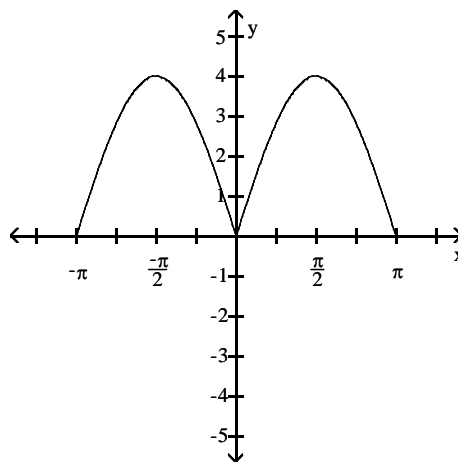

C)

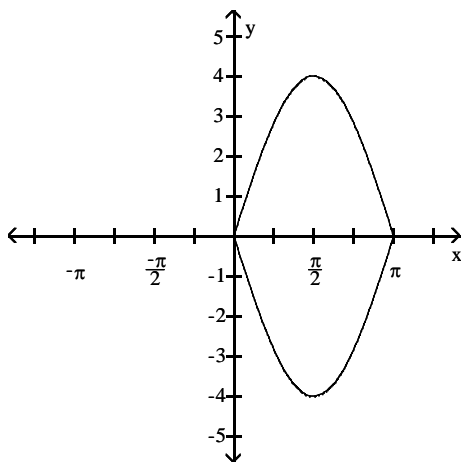

D)

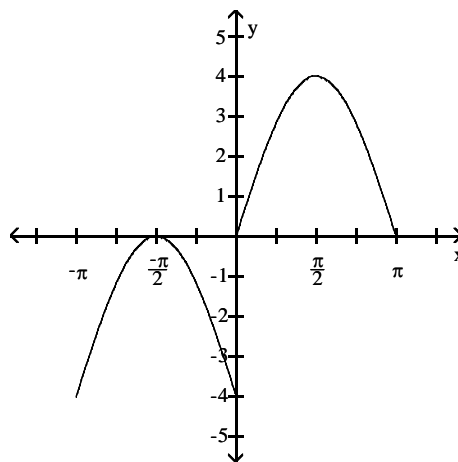

10) Symmetric with respect to the x-axis

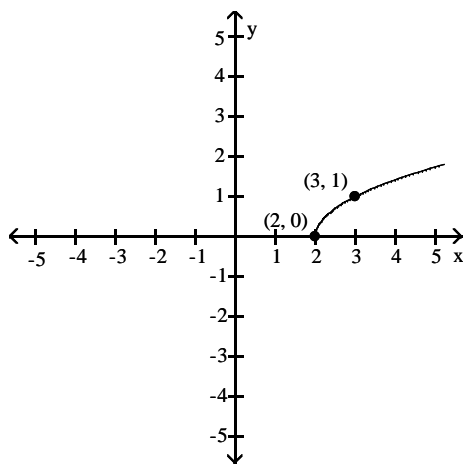

A)

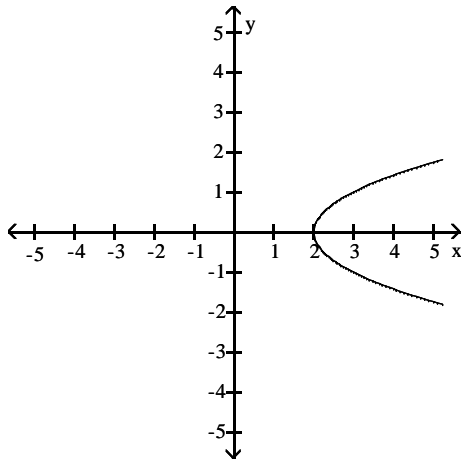

B)

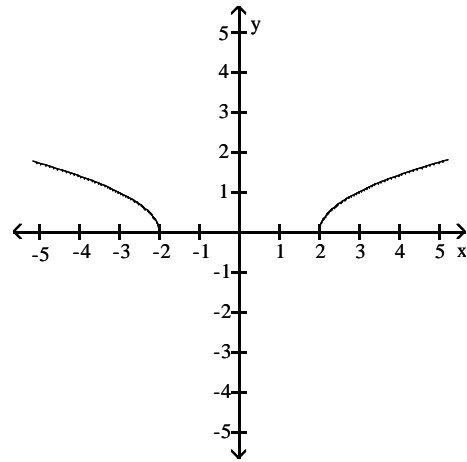

C)

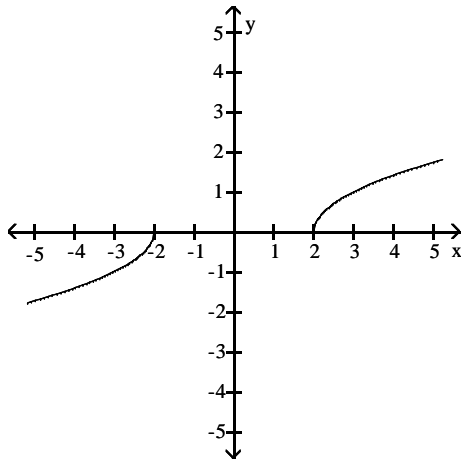

D)

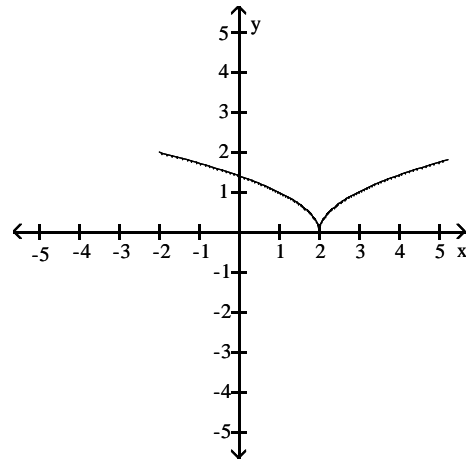

List the intercepts and type(s) of symmetry, if any.

11) $y^2 = x + 4$

- A) intercepts: $(-4, 0)$, $(0, 2)$, $(0, -2)$
 symmetric with respect to x-axis
- C) intercepts: $(0, -4)$, $(2, 0)$, $(-2, 0)$
 symmetric with respect to y-axis

- B) intercepts: $(4, 0)$, $(0, 2)$, $(0, -2)$
 symmetric with respect to x-axis
- D) intercepts: $(0, 4)$, $(2, 0)$, $(-2, 0)$
 symmetric with respect to y-axis

12) $9x^2 + y^2 = 9$

- A) intercepts: $(1, 0)$, $(-1, 0)$, $(0, 3)$, $(0, -3)$
 symmetric with respect to x-axis, y-axis, and origin
- B) intercepts: $(3, 0)$, $(-3, 0)$, $(0, 1)$, $(0, -1)$
 symmetric with respect to x-axis and y-axis
- C) intercepts: $(1, 0)$, $(-1, 0)$, $(0, 3)$, $(0, -3)$
 symmetric with respect to x-axis and y-axis
- D) intercepts: $(3, 0)$, $(-3, 0)$, $(0, 1)$, $(0, -1)$
 symmetric with respect to the origin

$$13) y = \frac{-x^5}{x^2 - 5}$$

- A) intercept: (0, 0)
symmetric with respect to origin
- C) intercept: (0, 0)
symmetric with respect to x-axis

- B) intercepts: $(\sqrt{5}, 0)$, $(-\sqrt{5}, 0)$, (0, 0)
symmetric with respect to origin
- D) intercept: (0, 0)
symmetric with respect to y-axis

Determine whether the graph of the equation is symmetric with respect to the x-axis, the y-axis, and/or the origin.

$$14) y = x - 3$$

- A) x-axis
- B) y-axis
- C) origin
- D) x-axis, y-axis, origin
- E) none

$$15) y = -2x$$

- A) origin
- B) x-axis
- C) y-axis
- D) x-axis, y-axis, origin
- E) none

$$16) x^2 + y - 81 = 0$$

- A) y-axis
- B) x-axis
- C) origin
- D) x-axis, y-axis, origin
- E) none

$$17) y^2 - x - 9 = 0$$

- A) x-axis
- B) y-axis
- C) origin
- D) x-axis, y-axis, origin
- E) none

18) $9x^2 + 16y^2 = 144$

- A) origin
- B) x-axis
- C) y-axis
- D) x-axis, y-axis, origin
- E) none

19) $16x^2 + y^2 = 16$

- A) origin
- B) x-axis
- C) y-axis
- D) x-axis, y-axis, origin
- E) none

20) $y = x^2 + 5x + 6$

- A) x-axis
- B) y-axis
- C) origin
- D) x-axis, y-axis, origin
- E) none

21) $y = \frac{7x}{x^2 + 49}$

- A) origin
- B) x-axis
- C) y-axis
- D) x-axis, y-axis, origin
- E) none

22) $y = \frac{x^2 - 64}{8x^4}$

- A) y-axis
- B) x-axis
- C) origin
- D) x-axis, y-axis, origin
- E) none

23) $y = 2x^2 + 1$

- A) y-axis
- B) x-axis
- C) origin
- D) x-axis, y-axis, origin
- E) none

24) $y = (x - 3)(x + 3)$

- A) x-axis
- B) y-axis
- C) origin
- D) x-axis, y-axis, origin
- E) none

25) $y = -7x^3 + 9x$

- A) origin
- B) x-axis
- C) y-axis
- D) x-axis, y-axis, origin
- E) none

26) $y = 5x^4 - 8x + 4$

- A) origin
- B) x-axis
- C) y-axis
- D) x-axis, y-axis, origin
- E) none

Solve the problem.

27) If a graph is symmetric with respect to the y-axis and it contains the point (5, -6), which of the following points is also on the graph?

- A) (-5, 6)
- B) (-5, -6)
- C) (5, -6)
- D) (-6, 5)

28) If a graph is symmetric with respect to the origin and it contains the point (-4, 7), which of the following points is also on the graph?

- A) (4, -7)
- B) (-4, -7)
- C) (4, 7)
- D) (7, -4)

3 Know How to Graph Key Equations

MULTIPLE CHOICE. Choose the one alternative that best completes the statement or answers the question.

Graph the equation by plotting points.

1) $y = x^3$

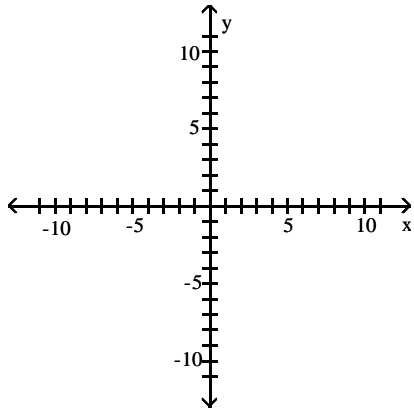

A)

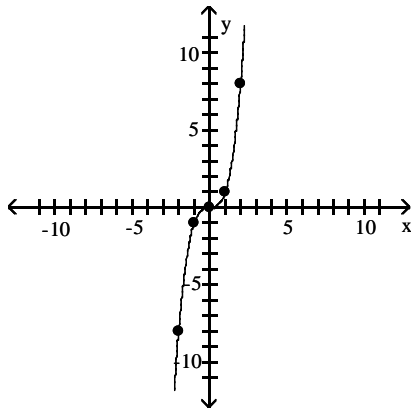

B)

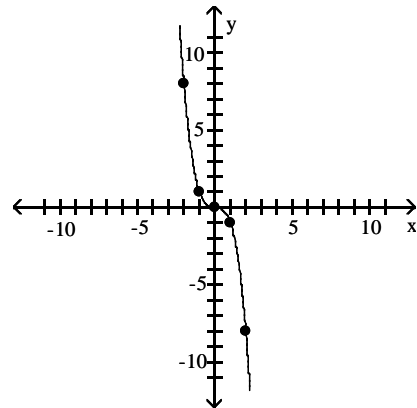

C)

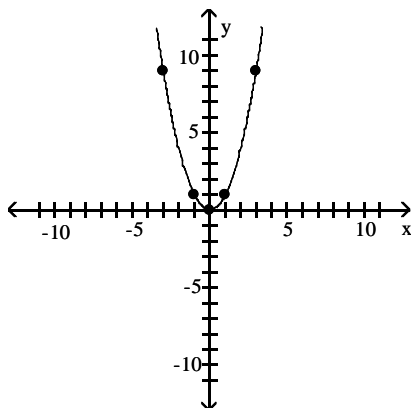

D)

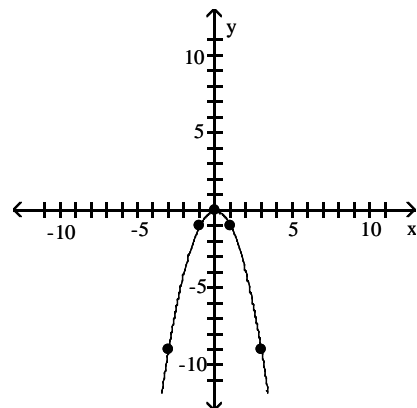

2) $x = y^2$

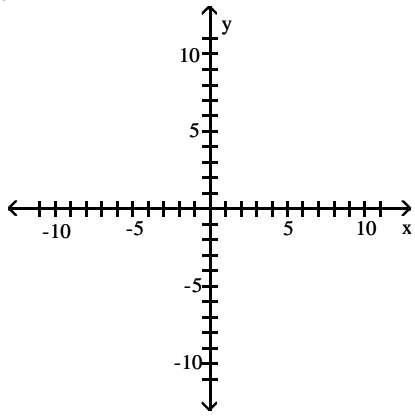

A)

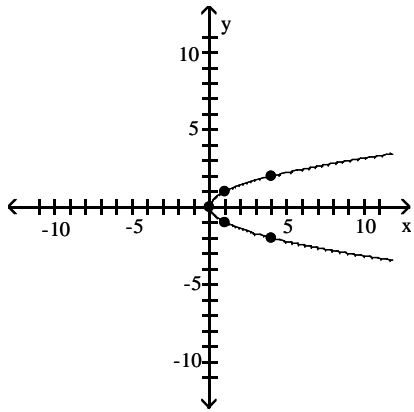

B)

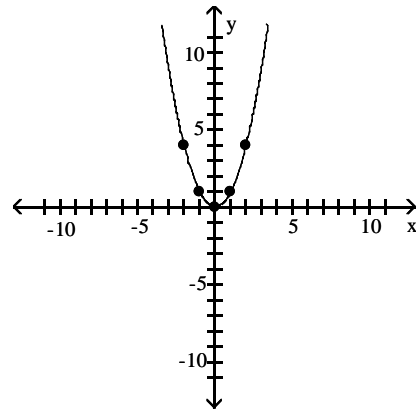

C)

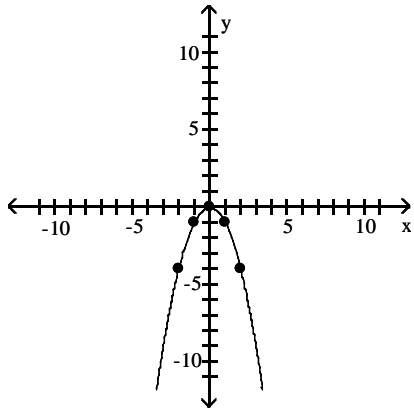

D)

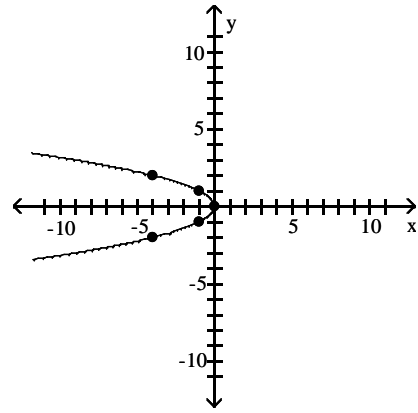

3) $y = \sqrt{x}$

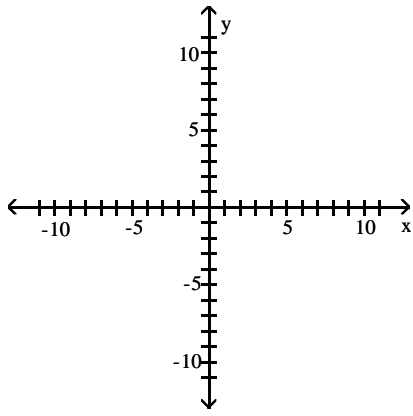

A)

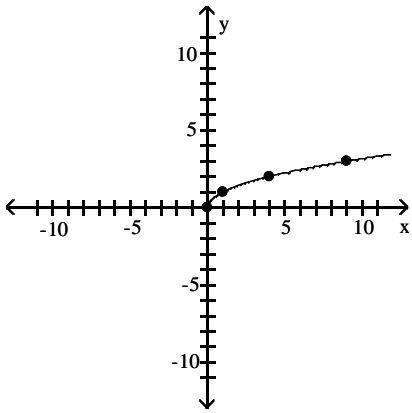

B)

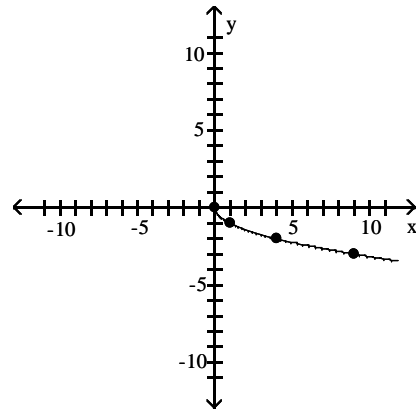

C)

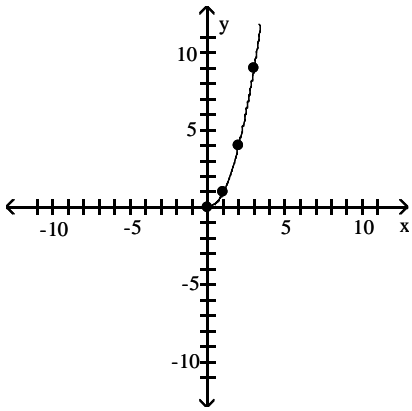

D)

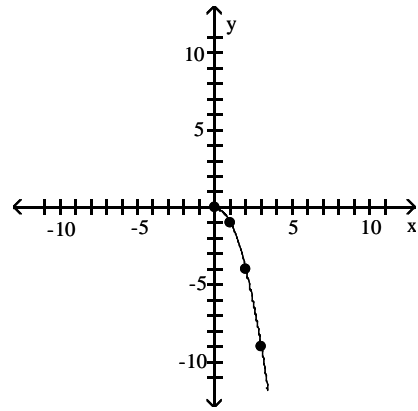

4) $y = \frac{1}{x}$

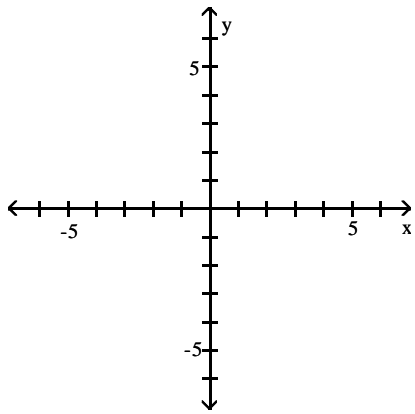

A)

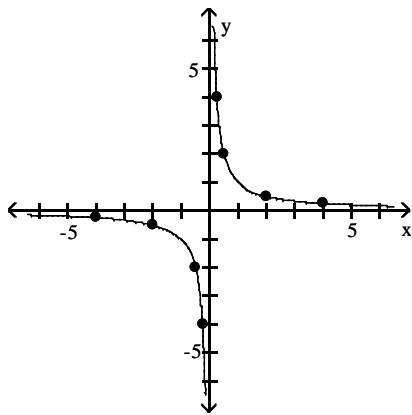

B)

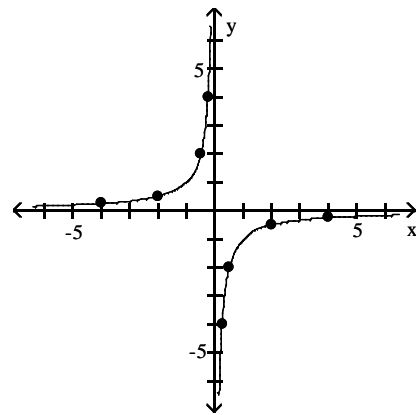

C)

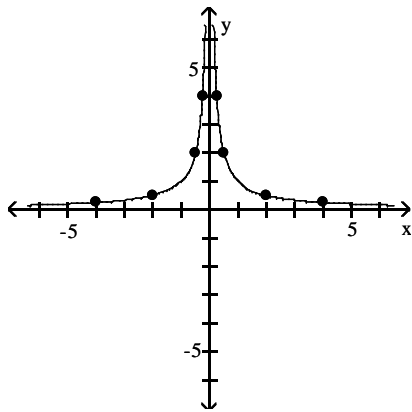

D)

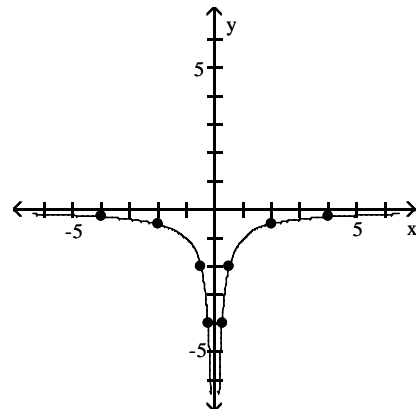

2.2 Lines

1 Calculate and Interpret the Slope of a Line

MULTIPLE CHOICE. Choose the one alternative that best completes the statement or answers the question.

Find the slope of the line through the points and interpret the slope.

1)

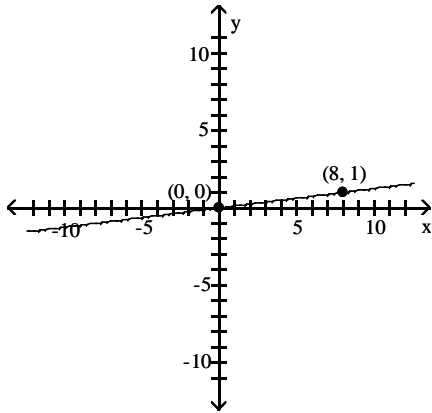

- A) $\frac{1}{8}$; for every 8-unit increase in x , y will increase by 1 unit
- B) 8; for every 1-unit increase in x , y will increase by 8 units
- C) $-\frac{1}{8}$; for every 8-unit increase in x , y will decrease by 1 unit
- D) -8; for every 1-unit increase in x , y will decrease by 8 units

Find the slope of the line.

2)

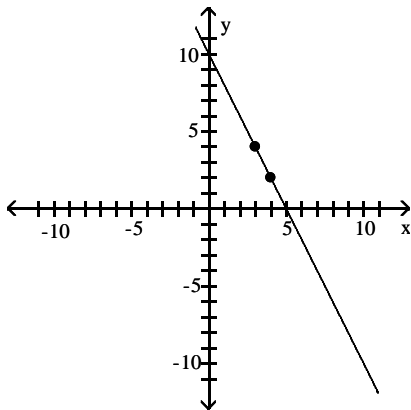

- A) -2
- B) $-\frac{1}{2}$
- C) 2
- D) $\frac{1}{2}$

3)

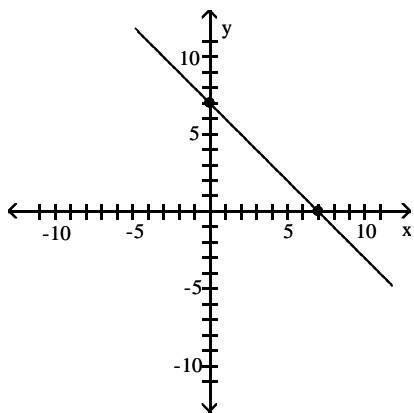

A) -1

B) 1

C) 7

D) -7

4)

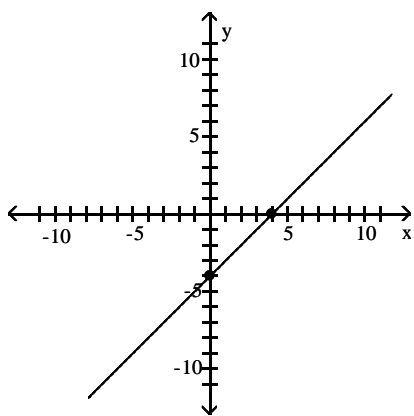

A) 1

B) -1

C) 4

D) -4

5)

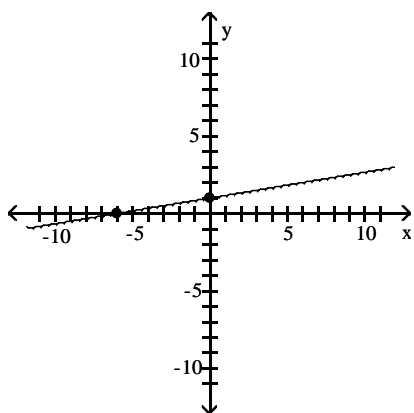

A) $\frac{1}{6}$

B) $-\frac{1}{6}$

C) 6

D) -6

Find the slope of the line containing the two points.

6) $(3, -4); (-2, 3)$

A) $-\frac{7}{5}$

B) $\frac{7}{5}$

C) $\frac{5}{7}$

D) $-\frac{5}{7}$

7) (2, 0); (0, 3)

A) $-\frac{3}{2}$

B) $\frac{3}{2}$

C) $\frac{2}{3}$

D) $-\frac{2}{3}$

8) (6, -6); (-7, -1)

A) $-\frac{5}{13}$

B) $\frac{5}{13}$

C) $-\frac{13}{5}$

D) $\frac{13}{5}$

9) (-9, -6); (-9, -7)

A) -1

B) 1

C) 0

D) undefined

10) (-7, -5); (-9, -5)

A) 0

B) $\frac{1}{2}$

C) -2

D) undefined

2 Graph Lines Given a Point and a Slope

MULTIPLE CHOICE. Choose the one alternative that best completes the statement or answers the question.

Graph the line containing the point P and having slope m.

1) $P = (-7, 2)$; $m = -\frac{1}{2}$

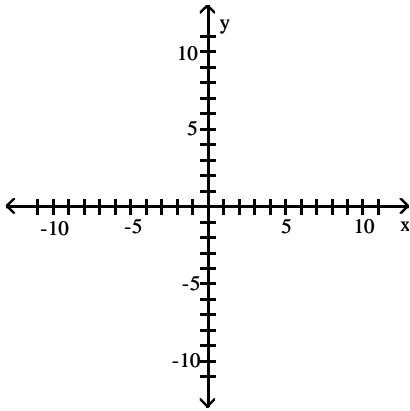

A)

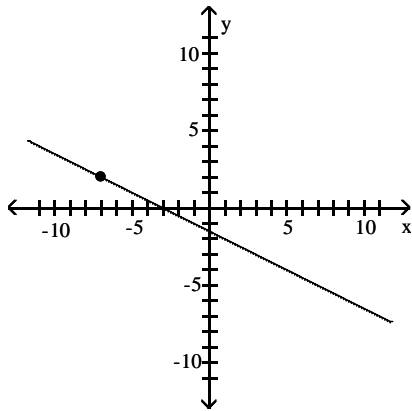

B)

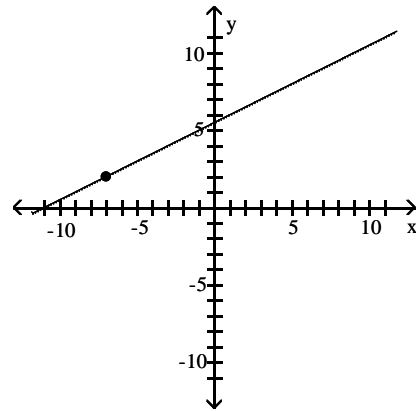

C)

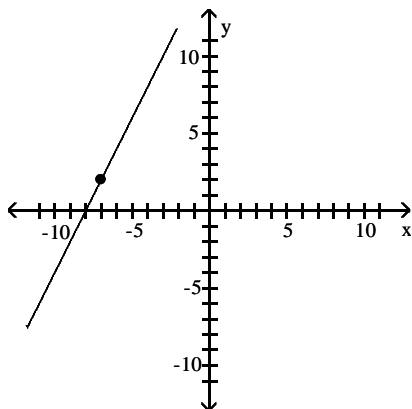

D)

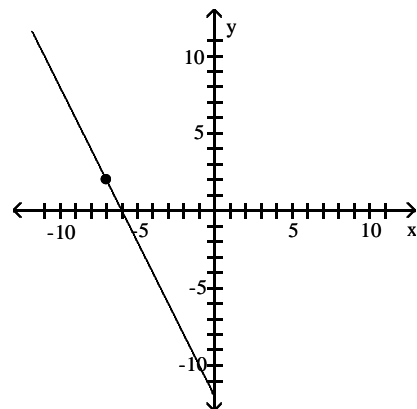

2) $P = (-2, -2)$; $m = \frac{3}{2}$

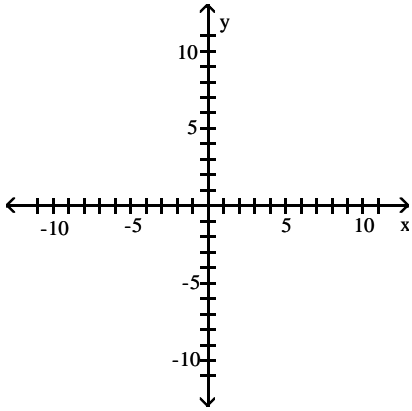

A)

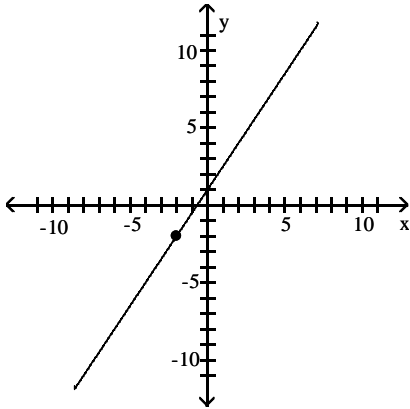

B)

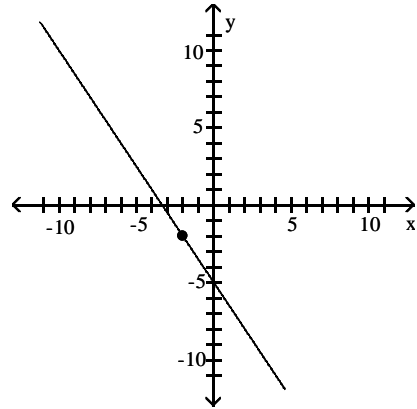

C)

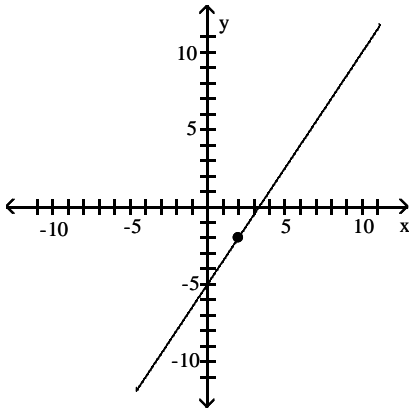

D)

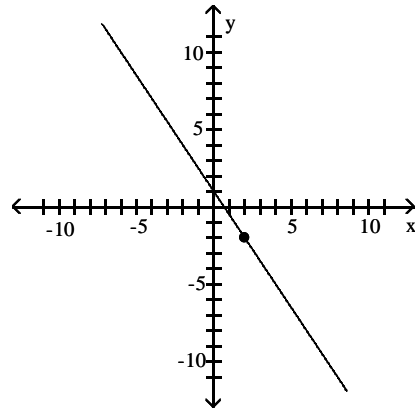

3) $P = (-2, -5)$; $m = -\frac{3}{4}$

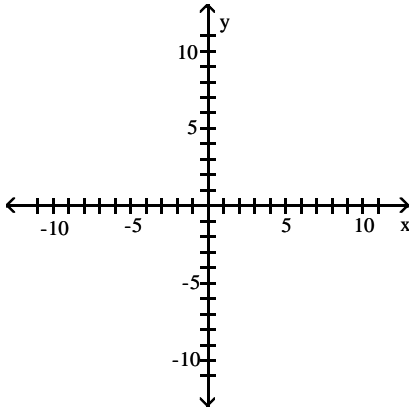

A)

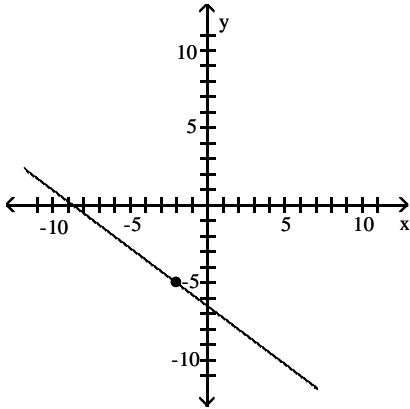

B)

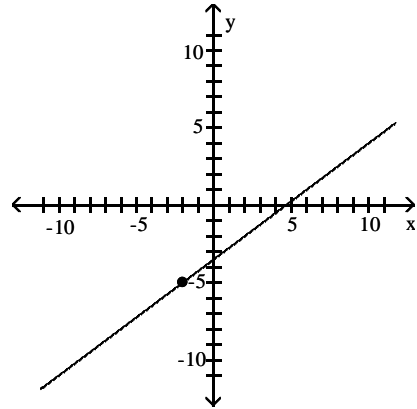

C)

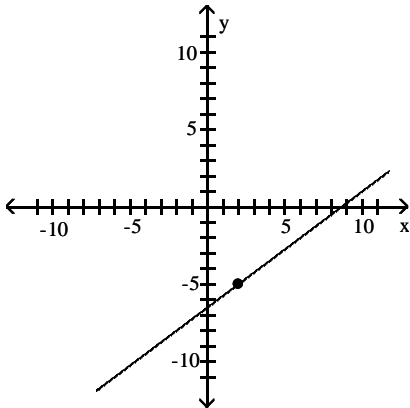

D)

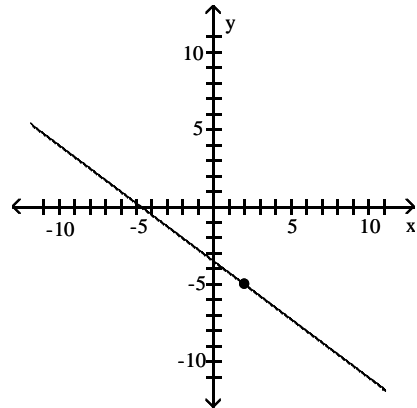

4) $P = (0, 4)$; $m = \frac{3}{2}$

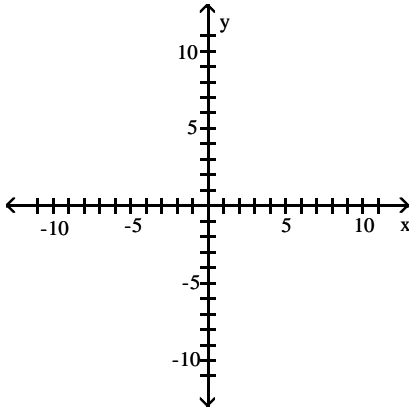

A)

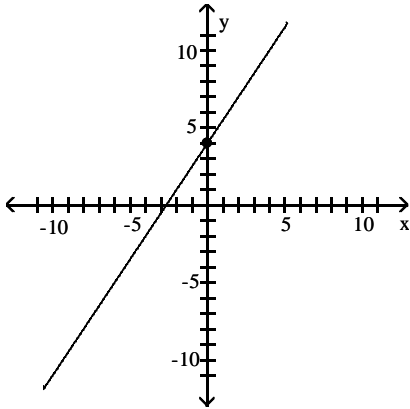

B)

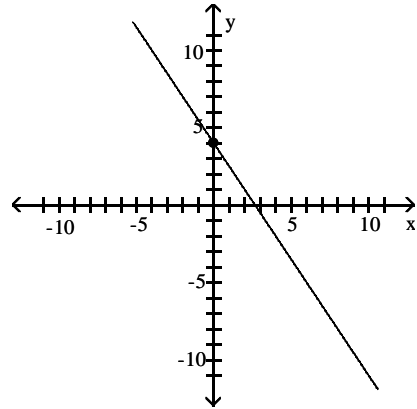

C)

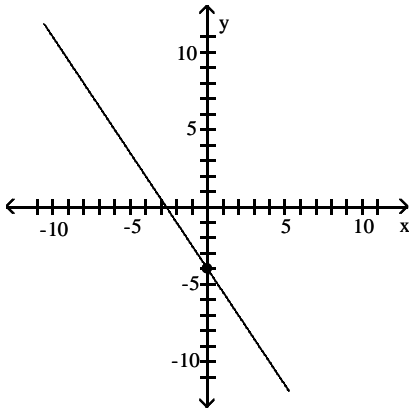

D)

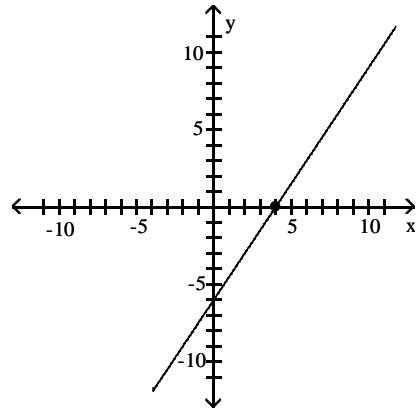

5) $P = (0, 4)$; $m = -\frac{1}{3}$

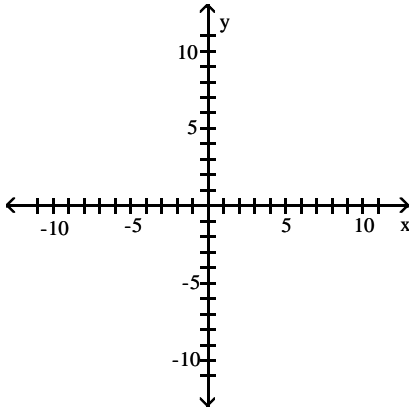

A)

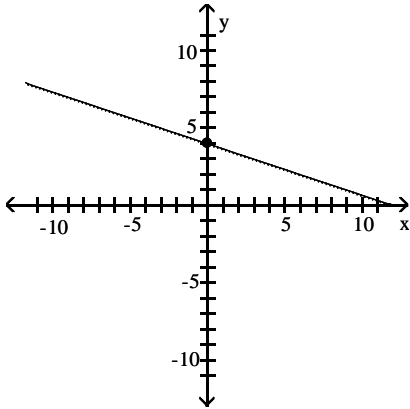

B)

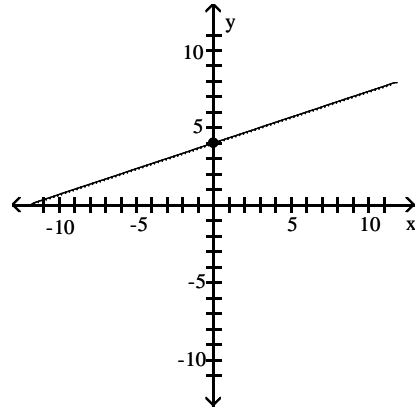

C)

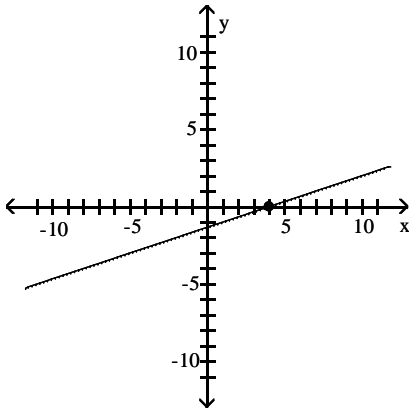

D)

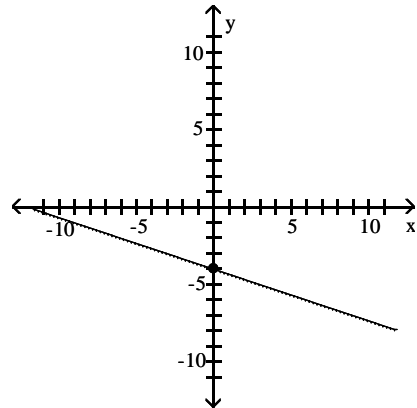

6) $P = (-3, 0)$; $m = 1$

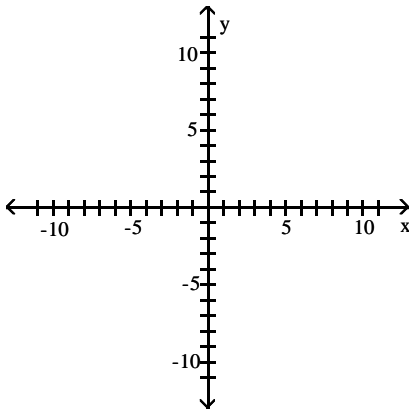

A)

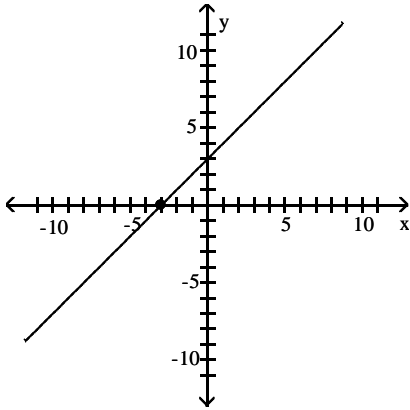

B)

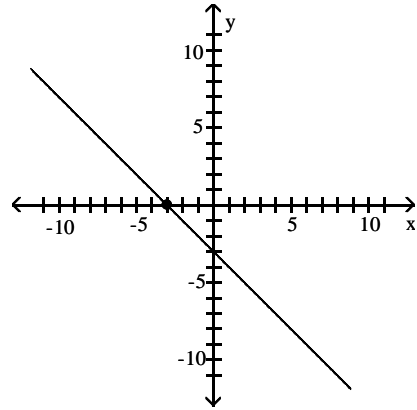

C)

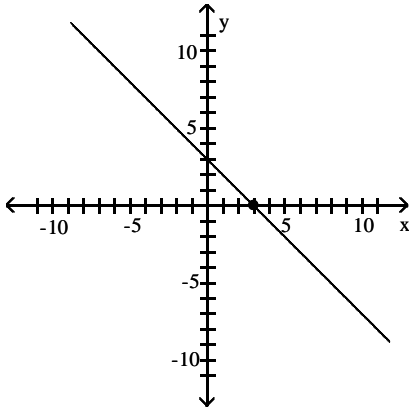

D)

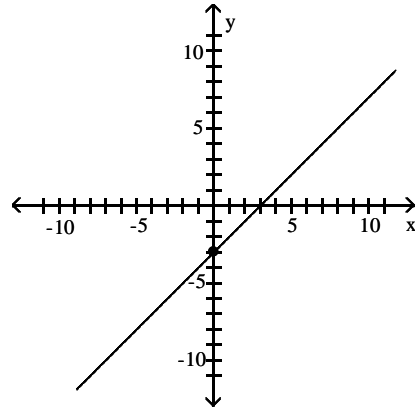

7) $P = (6, 0)$; $m = -\frac{1}{2}$

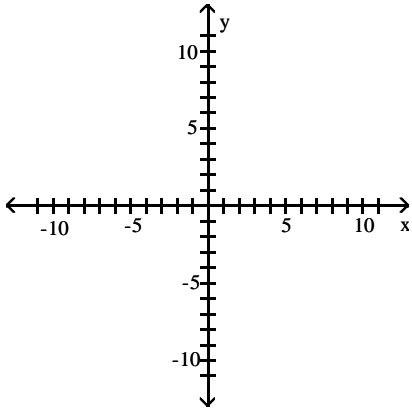

A)

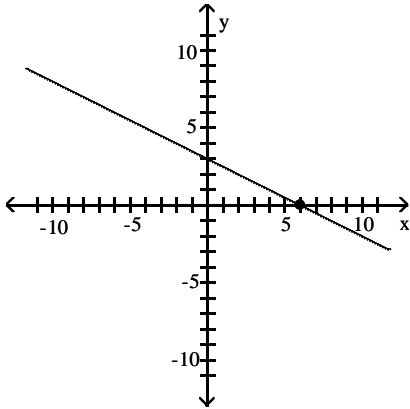

B)

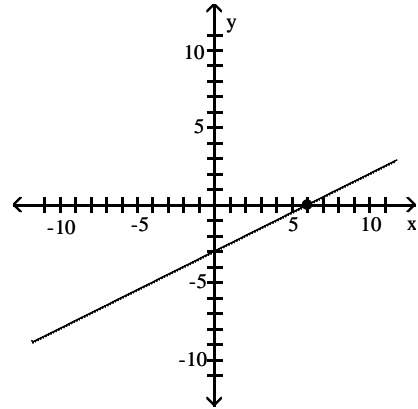

C)

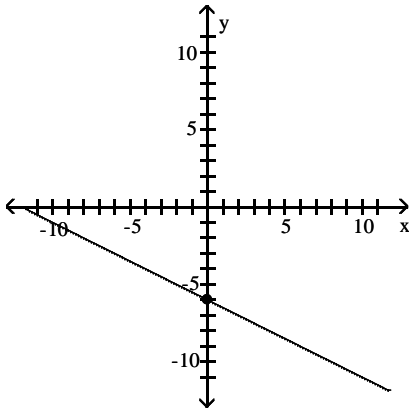

D)

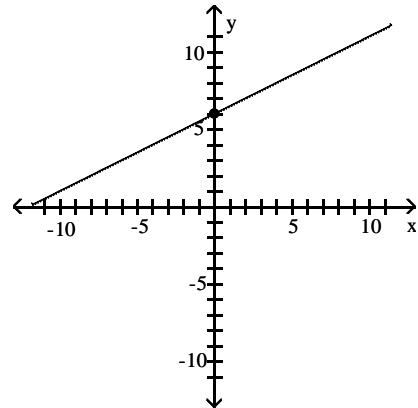

8) $P = (-2, 8)$; $m = 0$

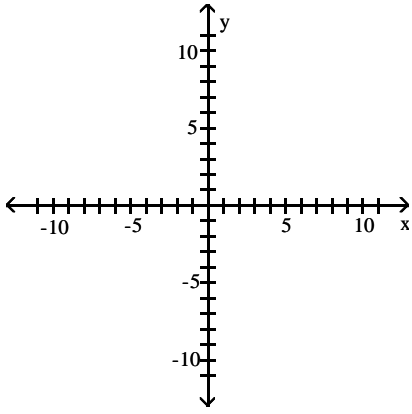

A)

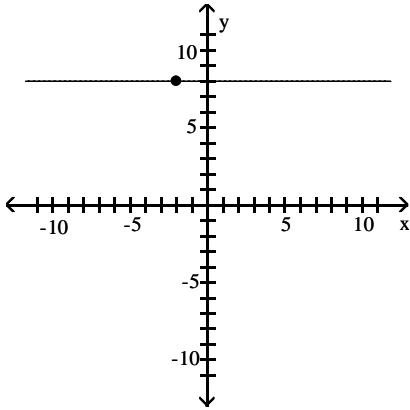

B)

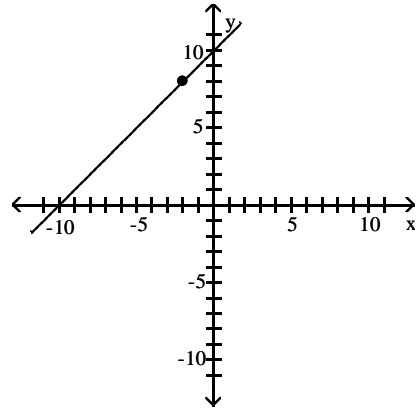

C)

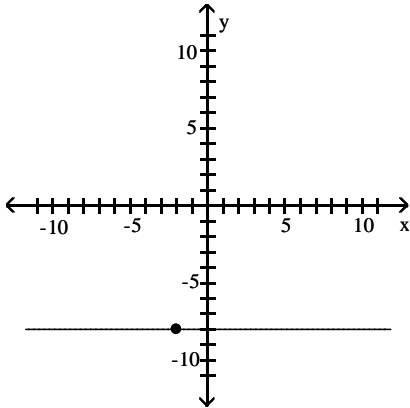

D)

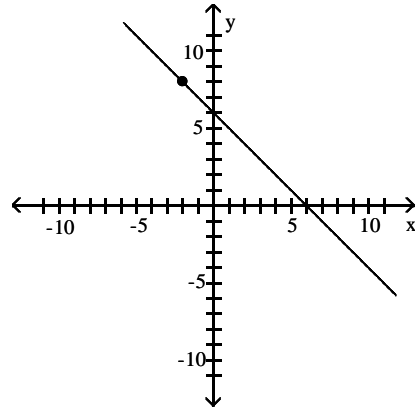

9) $P = (-1, -8)$; slope undefined

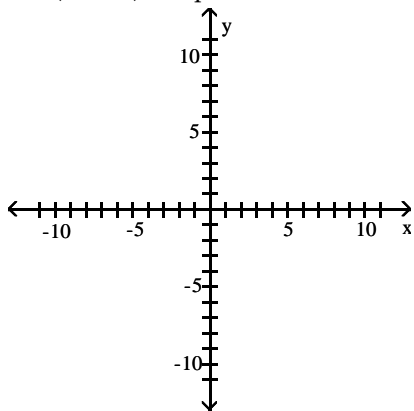

A)

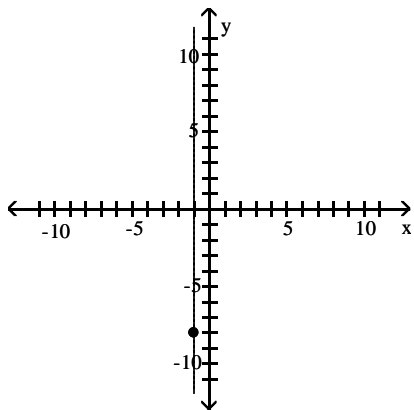

B)

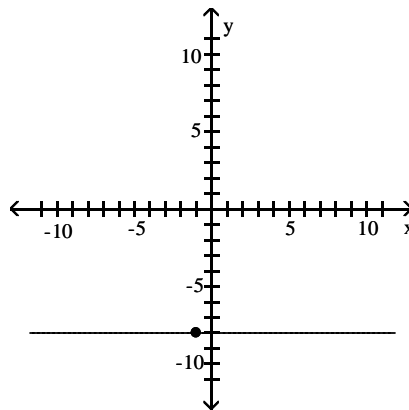

C)

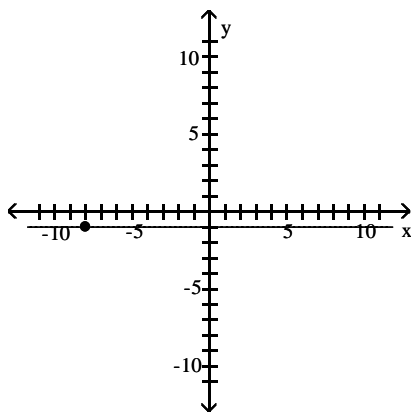

D)

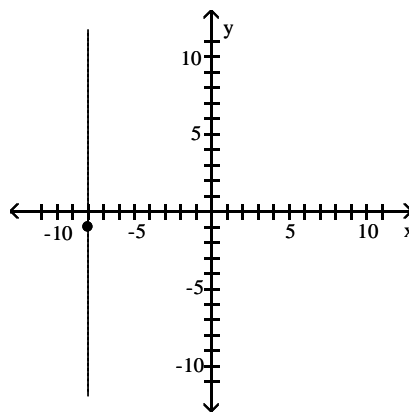

The slope and a point on a line are given. Use this information to determine the missing coordinate of the additional point.

10) Slope $\frac{2}{5}$; point $(-2, -4)$; additional point $(3, ?)$

A) -2

B) $\frac{5}{2}$

C) 0

D) $-\frac{2}{5}$

11) Slope -2; point $(9, 2)$; additional point $(8, ?)$

A) 4

B) 2

C) $-\frac{1}{2}$

D) $\frac{7}{4}$

12) Slope - 7; point (4, 7); additional point (6, ?)

A) -7

B) 7

C) -14

D) $\frac{1}{7}$

Match the graph with the correct equation.

13)

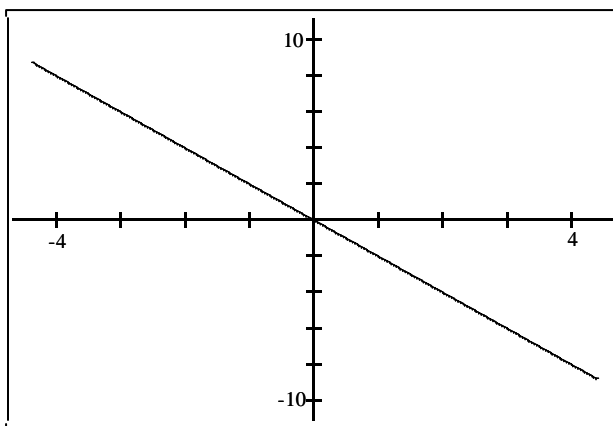

A) $y = -2x$

B) $y = 2x$

C) $y = -\frac{1}{2}x$

D) $y = \frac{1}{2}x$

14)

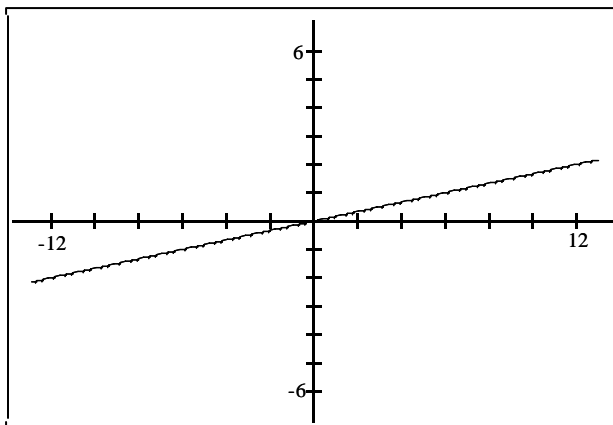

A) $y = \frac{1}{6}x$

B) $y = -\frac{1}{6}x$

C) $y = 6x$

D) $y = -6x$

3 Find the Equation of a Vertical Line

MULTIPLE CHOICE. Choose the one alternative that best completes the statement or answers the question.

Find the slope-intercept form of the equation of the line with the given properties.

1) Horizontal; containing the point (3, -7)

A) $y = -7$

B) $y = 3$

C) $x = -7$

D) $x = 3$

2) Slope = 0; containing the point (-2, -10)

A) $y = -10$

B) $y = -2$

C) $x = -10$

D) $x = -2$

3) Horizontal; containing the point $\left(-\frac{7}{8}, 4\right)$

A) $y = 4$

B) $y = -\frac{7}{8}$

C) $y = 0$

D) $y = -4$

4) Horizontal; containing the point $(-0.7, 3.3)$

A) $y = 3.3$

B) $y = -0.7$

C) $y = 2.6$

D) $y = 0$

Find the slope of the line and sketch its graph.

5) $y - 5 = 0$

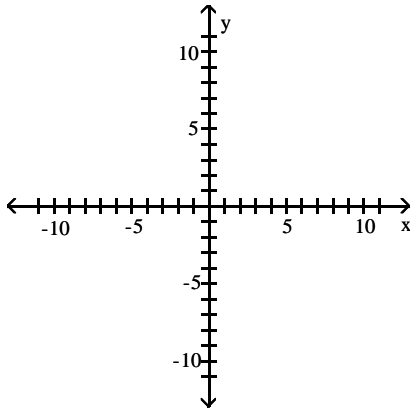

A) slope = 0

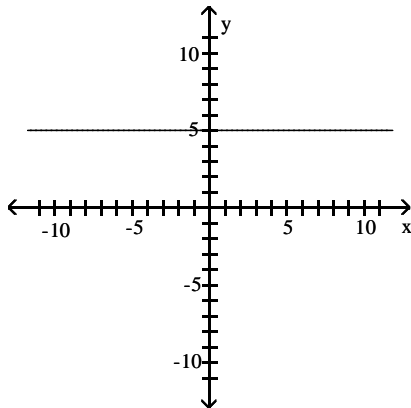

B) slope is undefined

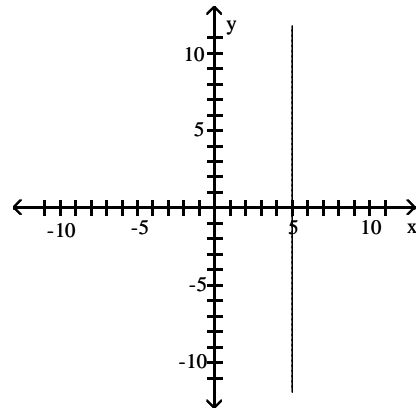

C) slope = 5

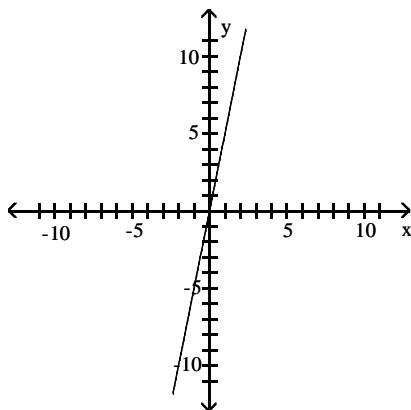

D) slope = $\frac{1}{5}$

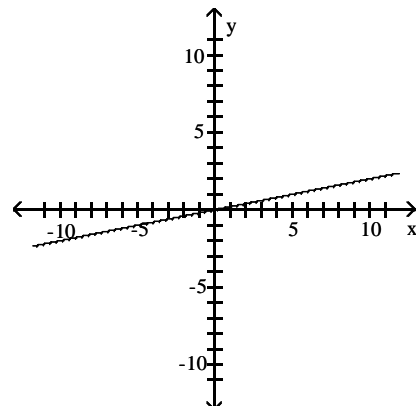

4 Use the Point-Slope Form of a Line; Identify Horizontal Lines

MULTIPLE CHOICE. Choose the one alternative that best completes the statement or answers the question.

Find the point-slope equation for the line with the given properties.

1) Slope = $\frac{5}{4}$; containing the point (2, 4)

A) $y - 4 = \frac{5}{4}(x - 2)$

B) $y + 4 = \frac{5}{4}(x + 2)$

C) $y - 2 = \frac{5}{4}(x - 4)$

D) $x + 4 = \frac{5}{4}(y + 2)$

2) Slope = $-\frac{3}{4}$; containing the point (2, 3)

A) $y - 3 = -\frac{3}{4}(x - 2)$

B) $y - 3 = \frac{3}{4}(x - 2)$

C) $y + 3 = -\frac{3}{4}(x + 2)$

D) $y - 3 = -\frac{3}{4}(x + 2)$

Find an equation for the line with the given properties. Express the answer using the slope-intercept form of the equation of a line.

3) Horizontal; containing the point (-1, -4)

A) $y = -4$

B) $y = -1$

C) $x = -4$

D) $x = -1$

4) Slope = 0; containing the point (-10, -4)

A) $y = -4$

B) $y = -10$

C) $x = -4$

D) $x = -10$

5) Horizontal; containing the point (-1.7, 6.6)

A) $y = 6.6$

B) $y = -1.7$

C) $y = 4.9$

D) $y = 0$

6) Horizontal; containing the point $\left(-\frac{1}{9}, 7\right)$

A) $y = 7$

B) $y = -\frac{1}{9}$

C) $y = 0$

D) $y = -7$

5 Find the Equation of a Line Given Two Points

MULTIPLE CHOICE. Choose the one alternative that best completes the statement or answers the question.

Find the equation of the line in slope-intercept form.

1)

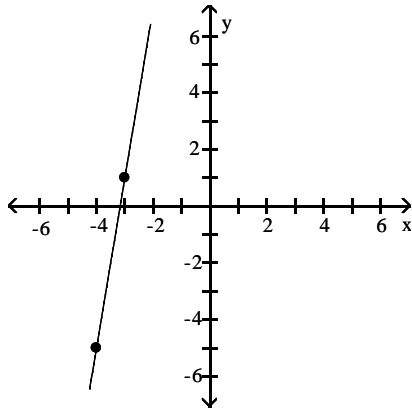

- A) $y = 6x + 19$ B) $y = \frac{1}{6}x + \frac{2}{19}$ C) $y = 6x - 3$ D) $y = 6x - 17$

Find an equation for the line, in the indicated form, with the given properties.

2) Containing the points $(-3, -3)$ and $(-6, 1)$; slope-intercept form

- A) $y = -\frac{4}{3}x - 7$ B) $y = mx - 7$ C) $y + 3 = -\frac{4}{3}(x + 3)$ D) $y = \frac{4}{3}x - 7$

3) Containing the points $(3, -5)$ and $(-6, 2)$; general form

- A) $7x + 9y = -24$ B) $-7x + 9y = -24$ C) $-8x + 8y = 32$ D) $8x - 8y = 32$

4) Containing the points $(7, 0)$ and $(0, -6)$; general form

- A) $6x - 7y = 42$ B) $6x + 7y = 42$ C) $y = -\frac{6}{7}x - 6$ D) $y = -\frac{6}{7}x + 7$

5) Containing the points $(-4, 9)$ and $(0, 2)$; general form

- A) $-7x - 4y = -8$ B) $7x - 4y = -8$ C) $13x + 2y = -4$ D) $-13x - 2y = -4$

6) Containing the points $(-2, 1)$ and $(0, 6)$; general form

- A) $5x - 2y = -12$ B) $-5x - 2y = -12$ C) $3x + 6y = -36$ D) $-3x - 6y = -36$

7) Containing the points $(8, 0)$ and $(-9, 2)$; general form

- A) $2x + 17y = 16$ B) $-2x + 17y = 16$ C) $-8x + 11y = 50$ D) $8x - 11y = 50$

8) Containing the points $(9, -1)$ and $(-8, 1)$; general form

- A) $2x + 17y = 1$ B) $-2x + 17y = 1$ C) $-10x + 9y = 71$ D) $10x - 9y = 71$

Solve.

- 9) The relationship between Celsius ($^{\circ}\text{C}$) and Fahrenheit ($^{\circ}\text{F}$) degrees of measuring temperature is linear. Find an equation relating $^{\circ}\text{C}$ and $^{\circ}\text{F}$ if 10°C corresponds to 50°F and 30°C corresponds to 86°F . Use the equation to find the Celsius measure of 1°F .

A) $C = \frac{5}{9}F - \frac{160}{9}; -\frac{155}{9}^{\circ}\text{C}$

B) $C = \frac{5}{9}F + \frac{160}{9}; \frac{55}{3}^{\circ}\text{C}$

C) $C = \frac{9}{5}F - 80; -\frac{391}{5}^{\circ}\text{C}$

D) $C = \frac{5}{9}F - 10; -\frac{85}{9}^{\circ}\text{C}$

- 10) A school has just purchased new computer equipment for \$17,000.00. The graph shows the depreciation of the equipment over 5 years. The point (0, 17,000) represents the purchase price and the point (5, 0) represents when the equipment will be replaced. Write a linear equation in slope-intercept form that relates the value of the equipment, y , to years after purchase x . Use the equation to predict the value of the equipment after 3 years.

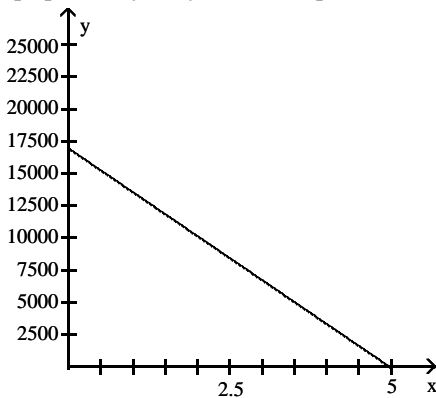

A) $y = -3400x + 17,000;$
value after 3 years is \$6800.00;

B) $y = 17,000x + 5;$
value after 3 years is \$6800.00

C) $y = 3400x - 17,000;$
value after 3 years is \$6800.00

D) $y = -17,000x + 17,000;$
value after 3 years is \$-34,000.00

- 11) The average value of a certain type of automobile was \$14,580 in 1993 and depreciated to \$6180 in 1997. Let y be the average value of the automobile in the year x , where $x = 0$ represents 1993. Write a linear equation that relates the average value of the automobile, y , to the year x .

A) $y = -2100x + 14,580$

B) $y = -2100x + 6180$

C) $y = -2100x - 2220$

D) $y = -\frac{1}{2100}x - 6180$

- 12) An investment is worth \$2922 in 1995. By 1999 it has grown to \$3454. Let y be the value of the investment in the year x , where $x = 0$ represents 1995. Write a linear equation that relates the value of the investment, y , to the year x .

A) $y = 133x + 2922$

B) $y = \frac{1}{133}x + 2922$

C) $y = -133x + 3986$

D) $y = -133x + 2922$

13) A faucet is used to add water to a large bottle that already contained some water. After it has been filling for 5 seconds, the gauge on the bottle indicates that it contains 29 ounces of water. After it has been filling for 12 seconds, the gauge indicates the bottle contains 64 ounces of water. Let y be the amount of water in the bottle x seconds after the faucet was turned on. Write a linear equation that relates the amount of water in the bottle, y , to the time x .

A) $y = 5x + 4$

B) $y = \frac{1}{5}x + 28$

C) $y = -5x + 54$

D) $y = 5x + 52$

14) When making a telephone call using a calling card, a call lasting 4 minutes cost \$1.50. A call lasting 13 minutes cost \$3.75. Let y be the cost of making a call lasting x minutes using a calling card. Write a linear equation that relates the cost of a making a call, y , to the time x .

A) $y = 0.25x + 0.5$

B) $y = 4x - \frac{29}{2}$

C) $y = -0.25x + 2.5$

D) $y = 0.25x - 9.25$

15) A vendor has learned that, by pricing hot dogs at \$1.00, sales will reach 139 hot dogs per day. Raising the price to \$1.75 will cause the sales to fall to 103 hot dogs per day. Let y be the number of hot dogs the vendor sells at x dollars each. Write a linear equation that relates the number of hot dogs sold per day, y , to the price x .

A) $y = -48x + 187$

B) $y = -\frac{1}{48}x + \frac{6671}{48}$

C) $y = 48x + 91$

D) $y = -48x - 187$

16) A vendor has learned that, by pricing caramel apples at \$1.50, sales will reach 89 caramel apples per day. Raising the price to \$2.25 will cause the sales to fall to 53 caramel apples per day. Let y be the number of caramel apples the vendor sells at x dollars each. Write a linear equation that relates the number of caramel apples sold per day to the price x .

A) $y = -48x + 161$

B) $y = -\frac{1}{48}x + \frac{2847}{32}$

C) $y = 48x + 17$

D) $y = -48x - 161$

6 Write the Equation of a Line in Slope-Intercept Form

MULTIPLE CHOICE. Choose the one alternative that best completes the statement or answers the question.

Find the slope-intercept form of the equation of the line with the given properties.

1) Slope = 3; containing the point $(-3, -4)$

A) $y = 3x + 5$

B) $y = 3x - 5$

C) $y = -3x - 5$

D) $y = -3x + 5$

2) Slope = 0; containing the point $(9, -6)$

A) $y = -6$

B) $y = 9$

C) $x = -6$

D) $x = 9$

3) Slope = 9; y -intercept = 20

A) $y = 9x + 20$

B) $y = 9x - 20$

C) $y = 20x - 9$

D) $y = 20x + 9$

4) x -intercept = 3; y -intercept = 2

A) $y = -\frac{2}{3}x + 2$

B) $y = -\frac{2}{3}x + 3$

C) $y = \frac{2}{3}x + 2$

D) $y = -\frac{3}{2}x + 3$

Write the equation in slope-intercept form.

5) $11x + 7y = 4$

A) $y = -\frac{11}{7}x + \frac{4}{7}$

B) $y = \frac{11}{7}x + \frac{4}{7}$

C) $y = 11x - 4$

D) $y = \frac{11}{7}x - \frac{4}{7}$

6) $6x + 7y = 9$

A) $y = \frac{6}{7}x + \frac{9}{7}$

B) $y = 6x + 10$

C) $y = \frac{10}{7}x + \frac{9}{7}$

D) $y = \frac{7}{6}x - \frac{9}{6}$

7) $7x - 4y = 1$

A) $y = \frac{7}{4}x - \frac{1}{4}$

B) $y = \frac{7}{4}x + \frac{1}{4}$

C) $y = \frac{4}{7}x + \frac{1}{7}$

D) $y = 7x - 1$

8) $x = 4y + 7$

A) $y = \frac{1}{4}x - \frac{7}{4}$

B) $y = 4x - 7$

C) $y = \frac{1}{4}x - 7$

D) $y = x - \frac{7}{4}$

Solve.

- 9) A truck rental company rents a moving truck one day by charging \$31 plus \$0.13 per mile. Write a linear equation that relates the cost C , in dollars, of renting the truck to the number x of miles driven. What is the cost of renting the truck if the truck is driven 120 miles?

A) $C = 0.13x + 31$; \$46.60

B) $C = 31x + 0.13$; \$3720.13

C) $C = 0.13x + 31$; \$32.56

D) $C = 0.13x - 31$; \$15.40

- 10) Each week a soft drink machine sells x cans of soda for \$0.75/soda. The cost to the owner of the soda machine for each soda is \$0.10. The weekly fixed cost for maintaining the soda machine is \$25/week. Write an equation that relates the weekly profit, P , in dollars to the number of cans sold each week. Then use the equation to find the weekly profit when 92 cans of soda are sold in a week.

A) $P = 0.65x - 25$; \$34.80

B) $P = 0.65x + 25$; \$84.80

C) $P = 0.75x - 25$; \$44.00

D) $P = 0.75x + 25$; \$94.00

- 11) Each day the commuter train transports x passengers to or from the city at \$1.75/passenger. The daily fixed cost for running the train is \$1200. Write an equation that relates the daily profit, P , in dollars to the number of passengers each day. Then use the equation to find the daily profit when the train has 920 passengers in a day.

A) $P = 1.75x - 1200$; \$410

B) $P = 1200 - 1.75x$; \$410

C) $P = 1.75x + 1200$; \$2810

D) $P = 1.75x$; \$1610

- 12) Each month a beauty salon gives x manicures for \$12.00/manicure. The cost to the owner of the beauty salon for each manicure is \$7.35. The monthly fixed cost to maintain a manicure station is \$120.00. Write an equation that relates the monthly profit, in dollars, to the number of manicures given each month. Then use the equation to find the monthly profit when 200 manicures are given in a month.

A) $P = 4.65x - 120$; \$810

B) $P = 12x - 120$; \$2280

C) $P = 7.35x - 120$; \$1350

D) $P = 4.65x$; \$930

13) Each month a gas station sells x gallons of gas at \$1.92/gallon. The cost to the owner of the gas station for each gallon of gas is \$1.32. The monthly fixed cost for running the gas station is \$37,000. Write an equation that relates the monthly profit, in dollars, to the number of gallons of gasoline sold. Then use the equation to find the monthly profit when 75,000 gallons of gas are sold in a month.

A) $P = 0.60x - 37,000$; \$8000

B) $P = 1.32x - 37,000$; \$62,000

C) $P = 1.92x - 37,000$; \$107,000

D) $P = 0.60x + 37,000$; \$82,000

7 Identify the Slope and y-Intercept of a Line from its Equation

MULTIPLE CHOICE. Choose the one alternative that best completes the statement or answers the question.

Find the slope and y-intercept of the line.

1) $y = -\frac{4}{5}x - 6$

A) slope = $-\frac{4}{5}$; y-intercept = -6

B) slope = -6 ; y-intercept = $-\frac{4}{5}$

C) slope = $-\frac{5}{4}$; y-intercept = 6

D) slope = $\frac{4}{5}$; y-intercept = 6

2) $x + y = 10$

A) slope = -1 ; y-intercept = 10

B) slope = 1 ; y-intercept = 10

C) slope = 0 ; y-intercept = 10

D) slope = -1 ; y-intercept = -10

3) $2x + y = -2$

A) slope = -2 ; y-intercept = -2

B) slope = $-\frac{1}{2}$; y-intercept = -1

C) slope = 2 ; y-intercept = -2

D) slope = -1 ; y-intercept = $-\frac{1}{2}$

4) $3x + 7y = 9$

A) slope = $\frac{3}{7}$; y-intercept = $\frac{9}{7}$

B) slope = 3 ; y-intercept = 13

C) slope = $\frac{13}{7}$; y-intercept = $\frac{9}{7}$

D) slope = $\frac{7}{3}$; y-intercept = $-\frac{9}{3}$

5) $10x + 9y = 19$

A) slope = $-\frac{10}{9}$; y-intercept = $\frac{19}{9}$

B) slope = $\frac{10}{9}$; y-intercept = $\frac{19}{9}$

C) slope = 10 ; y-intercept = 19

D) slope = $\frac{10}{9}$; y-intercept = $-\frac{19}{9}$

6) $8x - 7y = 3$

A) slope = $\frac{8}{7}$; y-intercept = $-\frac{3}{7}$

B) slope = $\frac{8}{7}$; y-intercept = $\frac{3}{7}$

C) slope = $\frac{7}{8}$; y-intercept = $\frac{3}{8}$

D) slope = 8 ; y-intercept = 3

7) $12x - 10y = 120$

A) slope = $\frac{6}{5}$; y-intercept = -12

B) slope = $-\frac{6}{5}$; y-intercept = 12

C) slope = $\frac{5}{6}$; y-intercept = 10

D) slope = 12; y-intercept = 120

8) $x + 8y = 1$

A) slope = $-\frac{1}{8}$; y-intercept = $\frac{1}{8}$

B) slope = 1; y-intercept = 1

C) slope = $\frac{1}{8}$; y-intercept = $\frac{1}{8}$

D) slope = -8; y-intercept = 8

9) $-x + 2y = 22$

A) slope = $\frac{1}{2}$; y-intercept = 11

B) slope = $-\frac{1}{2}$; y-intercept = 11

C) slope = -1; y-intercept = 22

D) slope = 2; y-intercept = -22

10) $y = -9$

A) slope = 0; y-intercept = -9

B) slope = -9; y-intercept = 0

C) slope = 1; y-intercept = -9

D) slope = 0; no y-intercept

11) $x = 2$

A) slope undefined; no y-intercept

B) slope = 0; y-intercept = 2

C) slope = 2; y-intercept = 0

D) slope undefined; y-intercept = 2

12) $y = -2x$

A) slope = -2; y-intercept = 0

B) slope = 2; y-intercept = 0

C) slope = $-\frac{1}{2}$; y-intercept = 0

D) slope = 0; y-intercept = -2

8 Graph Lines Written in General Form Using Intercepts

MULTIPLE CHOICE. Choose the one alternative that best completes the statement or answers the question.

Find the general form of the equation for the line with the given properties.

1) Slope = $\frac{3}{5}$; y-intercept = $\frac{6}{5}$

A) $3x - 5y = -6$

B) $3x + 5y = -6$

C) $y = \frac{3}{5}x + \frac{6}{5}$

D) $y = \frac{3}{5}x - \frac{6}{5}$

2) Slope = $-\frac{2}{7}$; containing the point (5, 4)

A) $2x + 7y = 38$

B) $2x - 7y = 38$

C) $2x + 7y = -38$

D) $7x + 2y = -38$

3) Slope = $-\frac{3}{4}$; containing the point (0, 4)

A) $3x + 4y = 16$

B) $3x - 4y = 16$

C) $3x + 4y = -16$

D) $4x + 3y = -16$

4) Slope = $\frac{2}{9}$; containing (0, 3)

A) $-2x + 9y = 27$

B) $-2x - 9y = 27$

C) $-2x + 9y = -27$

D) $9x - 2y = -27$

Find the slope of the line and sketch its graph.

5) $2x + 5y = 24$

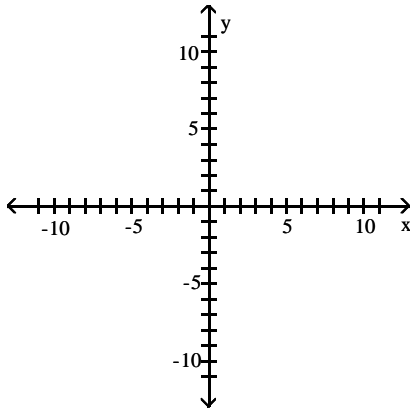

A) slope = $-\frac{2}{5}$

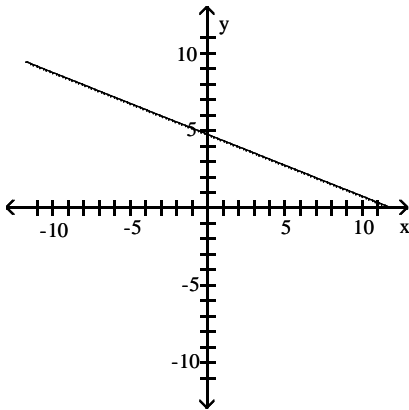

B) slope = $\frac{2}{5}$

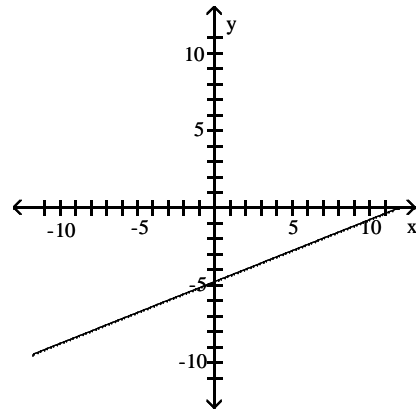

C) slope = $-\frac{5}{2}$

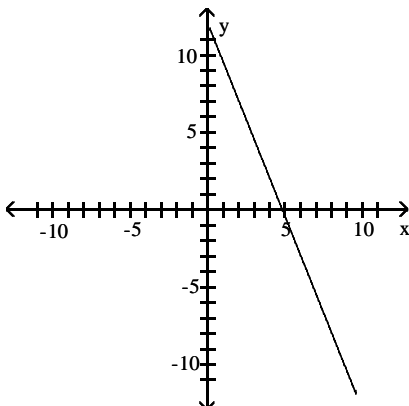

D) slope = $\frac{5}{2}$

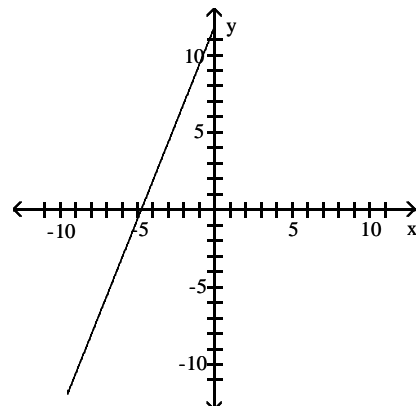

6) $3x - 5y = -11$

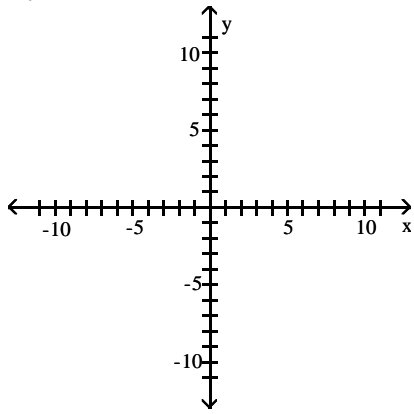

A) slope = $\frac{3}{5}$

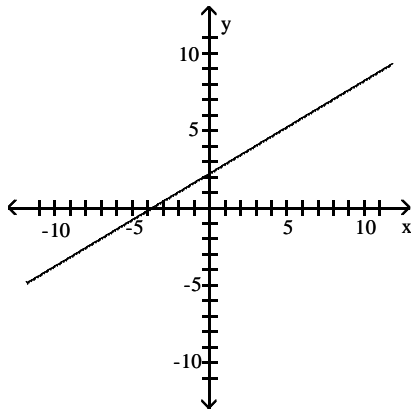

B) slope = $-\frac{3}{5}$

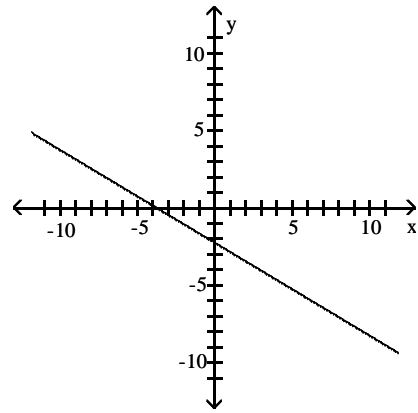

C) slope = $\frac{5}{3}$

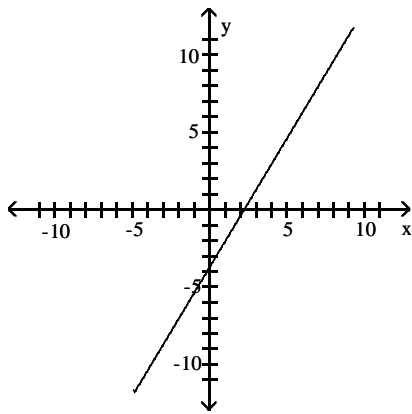

D) slope = $-\frac{5}{3}$

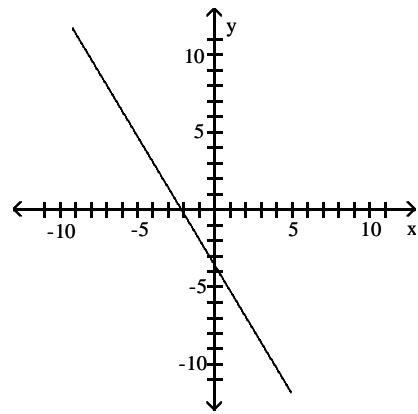

Solve the problem.

7) Find an equation in general form for the line graphed on a graphing utility.

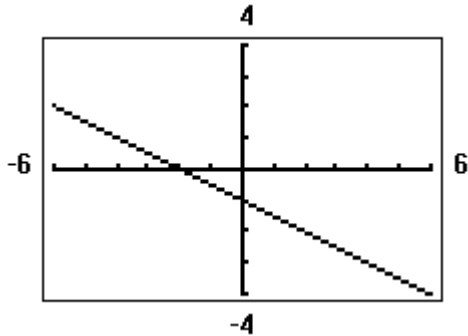

- A) $x + 2y = -2$ B) $y = -\frac{1}{2}x - 1$ C) $2x + y = -1$ D) $y = -2x - 1$

9 Find Equations of Parallel Lines

MULTIPLE CHOICE. Choose the one alternative that best completes the statement or answers the question.

Find an equation for the line with the given properties.

1) The solid line L contains the point (4, 5) and is parallel to the dotted line whose equation is $y = 2x$. Give the equation for the line L in slope-intercept form.

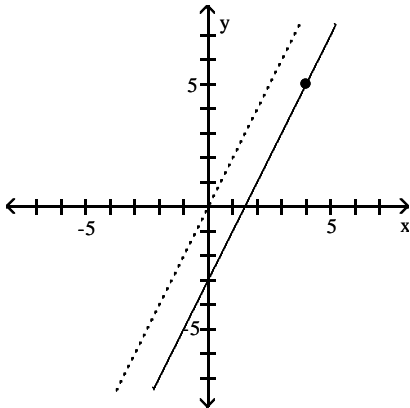

- A) $y = 2x - 3$ B) $y = 2x + 1$ C) $y - 5 = 2(x - 4)$ D) $y = 2x + b$
- 2) Parallel to the line $y = -3x$; containing the point (8, 6)
- A) $y = -3x + 30$ B) $y = -3x - 30$ C) $y - 6 = -3x - 8$ D) $y = -3x$
- 3) Parallel to the line $x - 3y = 2$; containing the point (0, 0)
- A) $y = \frac{1}{3}x$ B) $y = \frac{1}{3}x + 2$ C) $y = -\frac{1}{3}$ D) $y = -\frac{1}{3}x$
- 4) Parallel to the line $-2x - y = 2$; containing the point (0, 0)
- A) $y = -2x$ B) $y = \frac{1}{2}x + 2$ C) $y = \frac{1}{2}x$ D) $y = -\frac{1}{2}x$
- 5) Parallel to the line $y = 8$; containing the point (9, 1)
- A) $y = 1$ B) $y = -1$ C) $y = 8$ D) $y = 9$

6) Parallel to the line $x = 8$; containing the point $(4, 2)$

A) $x = 4$

B) $x = 2$

C) $y = 8$

D) $y = 2$

7) Parallel to the line $5x + 8y = -7$; containing the point $(5, 2)$

A) $5x + 8y = 41$

B) $5x - 8y = 41$

C) $8x + 5y = 2$

D) $5x + 8y = -7$

8) Parallel to the line $5x + 4y = -4$; x -intercept = -3

A) $5x + 4y = -15$

B) $5x + 4y = -12$

C) $4x - 5y = -12$

D) $4x - 5y = 15$

10 Find Equations of Perpendicular Lines

MULTIPLE CHOICE. Choose the one alternative that best completes the statement or answers the question.

Find an equation for the line with the given properties.

1) The solid line L contains the point $(2, 3)$ and is perpendicular to the dotted line whose equation is $y = 2x$. Give the equation of line L in slope-intercept form.

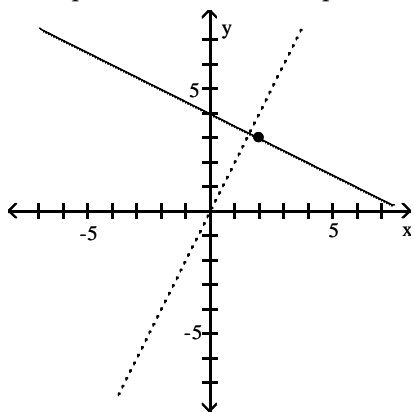

A) $y = -\frac{1}{2}x + 4$

B) $y - 3 = -\frac{1}{2}(x - 2)$

C) $y = \frac{1}{2}x + 4$

D) $y - 3 = 2(x - 2)$

2) Perpendicular to the line $y = -4x - 1$; containing the point $(4, -4)$

A) $y = \frac{1}{4}x - 5$

B) $y = -\frac{1}{4}x - 5$

C) $y = 4x - 5$

D) $y = -4x - 5$

3) Perpendicular to the line $y = \frac{1}{7}x + 6$; containing the point $(4, -3)$

A) $y = -7x + 25$

B) $y = 7x - 25$

C) $y = -7x - 25$

D) $y = -\frac{1}{7}x - \frac{25}{7}$

4) Perpendicular to the line $4x - y = 4$; containing the point $(0, 1)$

A) $y = -\frac{1}{4}x + 1$

B) $y = -\frac{1}{4}x + 4$

C) $y = \frac{3}{4}$

D) $y = \frac{1}{4}x + 1$

5) Perpendicular to the line $x - 2y = 8$; containing the point $(2, 2)$

A) $y = -2x + 6$

B) $y = 2x - 6$

C) $y = -2x - 6$

D) $y = -\frac{1}{2}x - 3$

6) Perpendicular to the line $y = -5$; containing the point $(8, 2)$

A) $x = 8$

B) $x = 2$

C) $y = 8$

D) $y = 2$

7) Perpendicular to the line $x = 4$; containing the point $(7, 3)$

A) $y = 3$

B) $x = 3$

C) $y = 7$

D) $x = 7$

8) Perpendicular to the line $-7x - 9y = -35$; containing the point $(-4, -7)$

A) $9x - 7y = 13$

B) $9x + 7y = 13$

C) $-7x + 9 = -7$

D) $-4x + 9y = -35$

9) Perpendicular to the line $-6x - 7y = 69$; containing the point $(-1, -10)$

A) $-7x + 6y = -53$

B) $-7x - 6y = -53$

C) $-6x + 7y = -53$

D) $-7x - 6y = 69$

10) Perpendicular to the line $3x + 5y = -2$; y -intercept = 2

A) $5x - 3y = -6$

B) $3x + 5y = 10$

C) $5x - 3y = 10$

D) $3x + 5y = 6$

Decide whether the pair of lines is parallel, perpendicular, or neither.

11) $3x - 8y = 10$

$32x + 12y = -14$

A) parallel

B) perpendicular

C) neither

12) $3x - 6y = -13$

$18x + 9y = -18$

A) parallel

B) perpendicular

C) neither

13) $12x + 4y = 16$

$21x + 7y = 31$

A) parallel

B) perpendicular

C) neither

2.3 Circles

1 Write the Standard Form of the Equation of a Circle

MULTIPLE CHOICE. Choose the one alternative that best completes the statement or answers the question.

Write the standard form of the equation of the circle.

1)

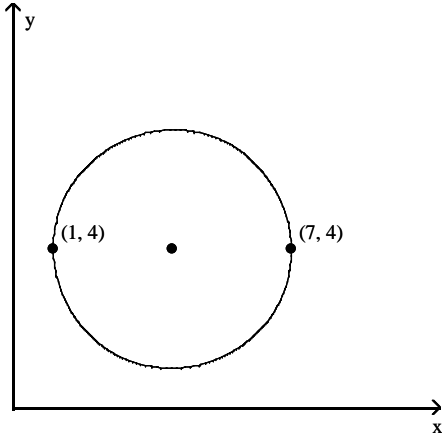

A) $(x - 4)^2 + (y - 4)^2 = 9$

B) $(x - 4)^2 + (y - 4)^2 = 3$

C) $(x + 4)^2 + (y + 4)^2 = 9$

D) $(x + 4)^2 + (y + 4)^2 = 3$

2)

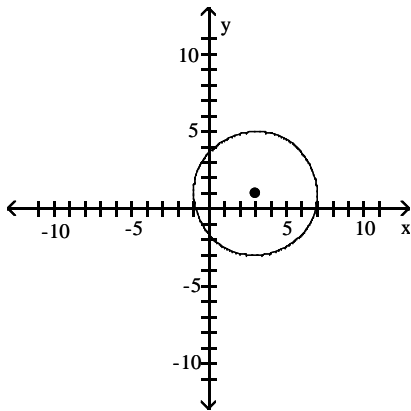

A) $(x - 3)^2 + (y - 1)^2 = 16$

B) $(x + 3)^2 + (y + 1)^2 = 16$

C) $(x - 1)^2 + (y - 3)^2 = 16$

D) $(x + 1)^2 + (y + 3)^2 = 16$

Write the standard form of the equation of the circle with radius r and center (h, k) .

3) $r = 2$; $(h, k) = (0, 0)$

A) $x^2 + y^2 = 4$

B) $x^2 + y^2 = 2$

C) $(x - 2)^2 + (y - 2)^2 = 4$

D) $(x - 2)^2 + (y - 2)^2 = 2$

4) $r = 3$; $(h, k) = (6, -6)$

A) $(x - 6)^2 + (y + 6)^2 = 9$

B) $(x + 6)^2 + (y - 6)^2 = 9$

C) $(x - 6)^2 + (y + 6)^2 = 3$

D) $(x + 6)^2 + (y - 6)^2 = 3$

5) $r = 4$; $(h, k) = (1, 0)$

A) $(x - 1)^2 + y^2 = 16$

B) $(x + 1)^2 + y^2 = 16$

C) $x^2 + (y - 1)^2 = 4$

D) $x^2 + (y + 1)^2 = 4$

6) $r = 6$; $(h, k) = (0, -2)$

A) $x^2 + (y + 2)^2 = 36$

B) $x^2 + (y - 2)^2 = 6$

C) $(x + 2)^2 + y^2 = 36$

D) $(x - 2)^2 + y^2 = 36$

7) $r = \sqrt{2}$; $(h, k) = (-4, 4)$

A) $(x + 4)^2 + (y - 4)^2 = 2$

B) $(x - 4)^2 + (y + 4)^2 = 2$

C) $(x - 4)^2 + (y + 4)^2 = 4$

D) $(x + 4)^2 + (y - 4)^2 = 4$

8) $r = \sqrt{5}$; $(h, k) = (0, -4)$

A) $x^2 + (y + 4)^2 = 5$

B) $x^2 + (y - 4)^2 = 5$

C) $(x + 4)^2 + y^2 = 25$

D) $(x - 4)^2 + y^2 = 25$

Solve the problem.

9) Find the equation of a circle in standard form where C(6, -2) and D(-4, 4) are endpoints of a diameter.

A) $(x - 1)^2 + (y - 1)^2 = 34$

B) $(x + 1)^2 + (y + 1)^2 = 34$

C) $(x - 1)^2 + (y - 1)^2 = 136$

D) $(x + 1)^2 + (y + 1)^2 = 136$

10) Find the equation of a circle in standard form with center at the point (-3, 2) and tangent to the line $y = 4$.

A) $(x + 3)^2 + (y - 2)^2 = 4$

B) $(x + 3)^2 + (y - 2)^2 = 16$

C) $(x - 3)^2 + (y + 2)^2 = 4$

D) $(x - 3)^2 + (y + 2)^2 = 16$

11) Find the equation of a circle in standard form that is tangent to the line $x = -3$ at (-3, 5) and also tangent to the line $x = 9$.

A) $(x - 3)^2 + (y - 5)^2 = 36$

B) $(x + 3)^2 + (y - 5)^2 = 36$

C) $(x - 3)^2 + (y + 5)^2 = 36$

D) $(x + 3)^2 + (y + 5)^2 = 36$

Find the center (h, k) and radius r of the circle with the given equation.

12) $x^2 + y^2 = 16$

A) $(h, k) = (0, 0)$; $r = 4$

B) $(h, k) = (0, 0)$; $r = 16$

C) $(h, k) = (4, 4)$; $r = 4$

D) $(h, k) = (4, 4)$; $r = 16$

13) $(x + 8)^2 + (y - 10)^2 = 16$

A) $(h, k) = (-8, 10)$; $r = 4$

B) $(h, k) = (-8, 10)$; $r = 16$

C) $(h, k) = (10, -8)$; $r = 4$

D) $(h, k) = (10, -8)$; $r = 16$

14) $(x + 10)^2 + y^2 = 4$

A) $(h, k) = (-10, 0)$; $r = 2$

B) $(h, k) = (0, -10)$; $r = 2$

C) $(h, k) = (0, -10)$; $r = 4$

D) $(h, k) = (-10, 0)$; $r = 4$

15) $x^2 + (y + 1)^2 = 121$

A) $(h, k) = (0, -1); r = 11$

C) $(h, k) = (-1, 0); r = 121$

B) $(h, k) = (-1, 0); r = 11$

D) $(h, k) = (0, -1); r = 121$

16) $2(x - 5)^2 + 2(y - 1)^2 = 12$

A) $(h, k) = (5, 1); r = \sqrt{6}$

C) $(h, k) = (-5, -1); r = \sqrt{6}$

B) $(h, k) = (5, 1); r = 2\sqrt{6}$

D) $(h, k) = (-5, -1); r = 2\sqrt{6}$

Solve the problem.

17) Find the standard form of the equation of the circle. Assume that the center has integer coordinates and the radius is an integer.

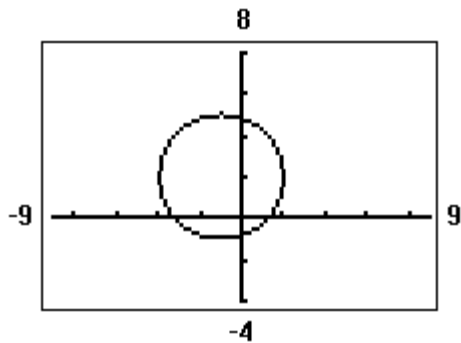

A) $(x + 1)^2 + (y - 2)^2 = 9$

C) $x^2 + y^2 + 2x - 4y - 4 = 0$

B) $(x - 1)^2 + (y + 2)^2 = 9$

D) $x^2 + y^2 - 2x + 4y - 4 = 0$

2 Graph a Circle by Hand and by Using a Graphing Utility

MULTIPLE CHOICE. Choose the one alternative that best completes the statement or answers the question.

Graph the circle with radius r and center (h, k) .

1) $r = 4$; $(h, k) = (0, 0)$

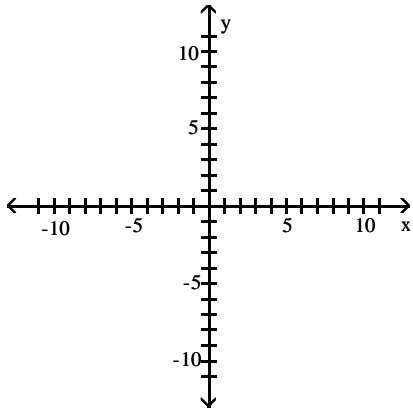

A)

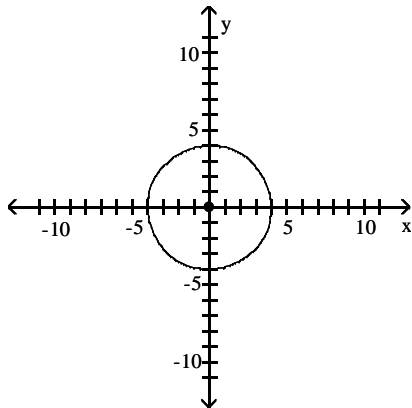

B)

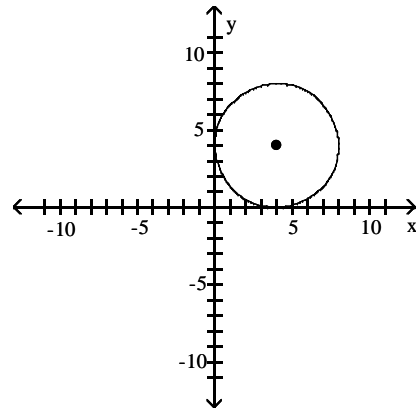

C)

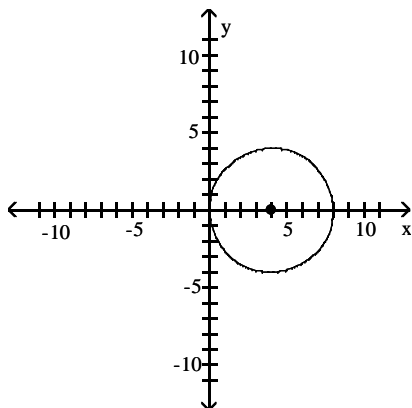

D)

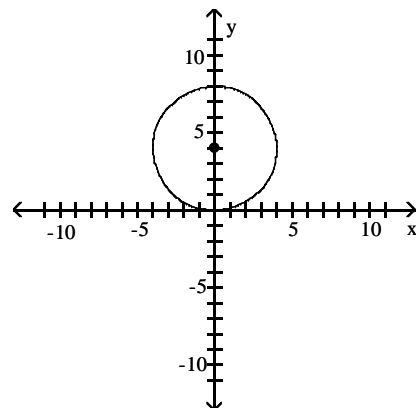

2) $r = 6$; $(h, k) = (0, 4)$

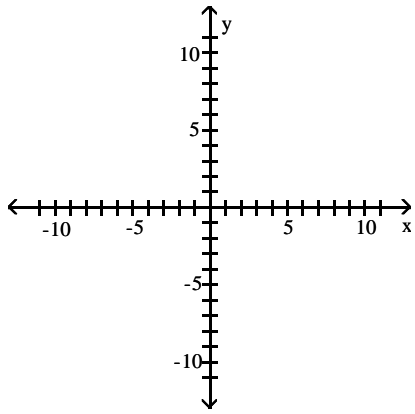

A)

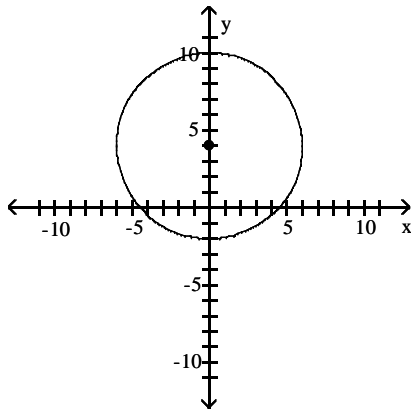

B)

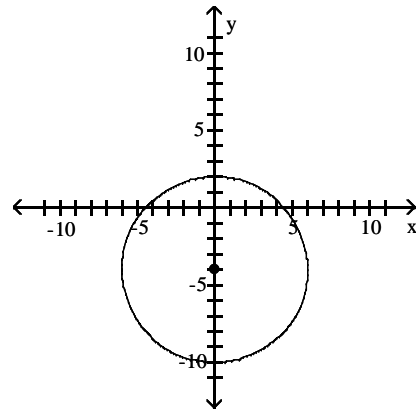

C)

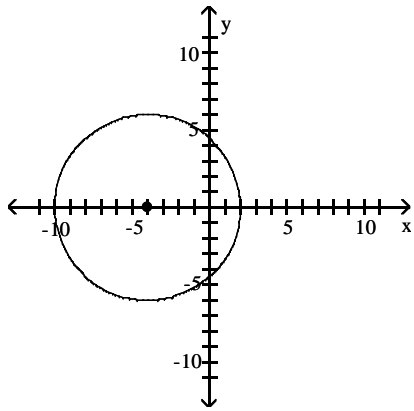

D)

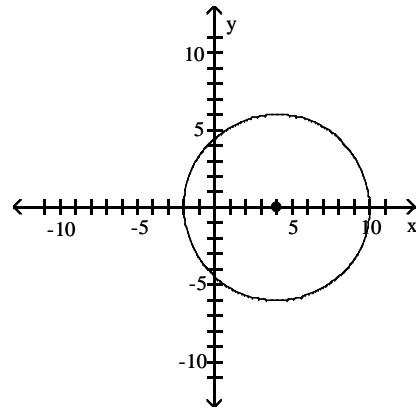

3) $r = 4$; $(h, k) = (2, 0)$

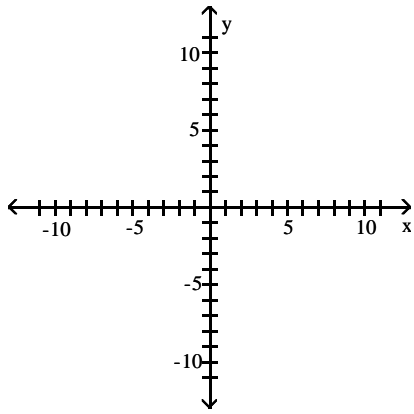

A)

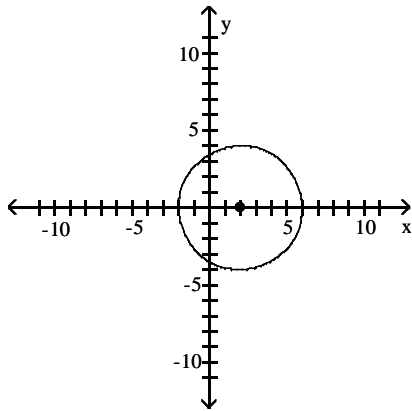

B)

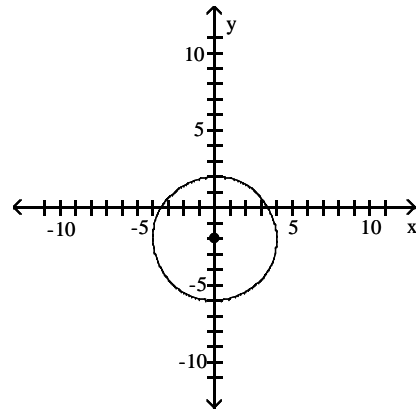

C)

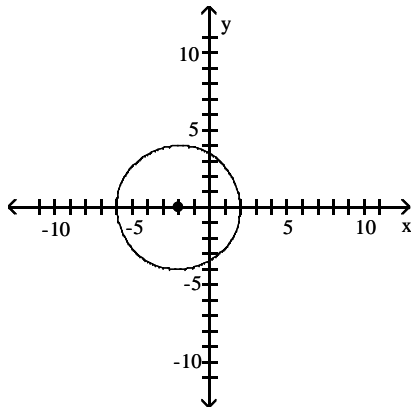

D)

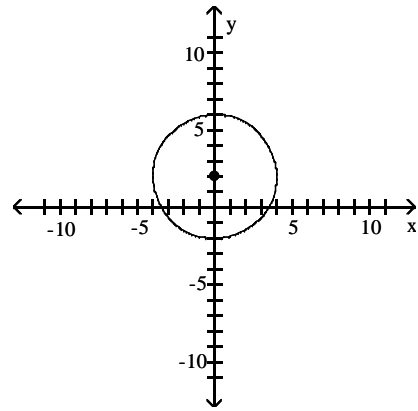

4) $r = 2$; $(h, k) = (3, -4)$

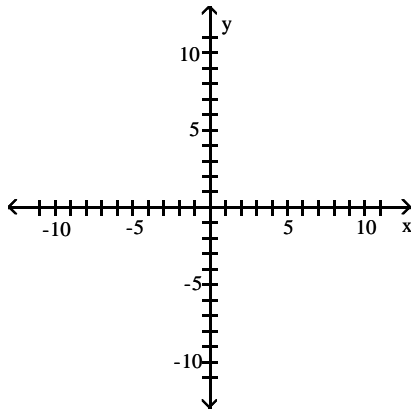

A)

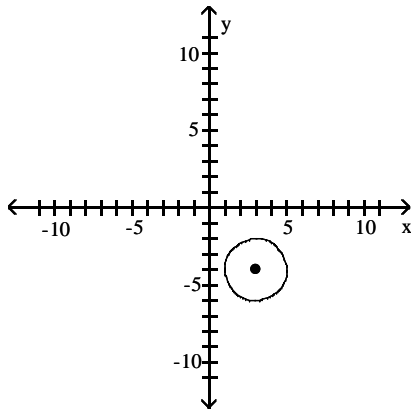

B)

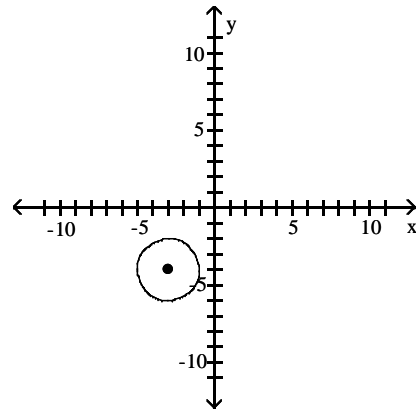

C)

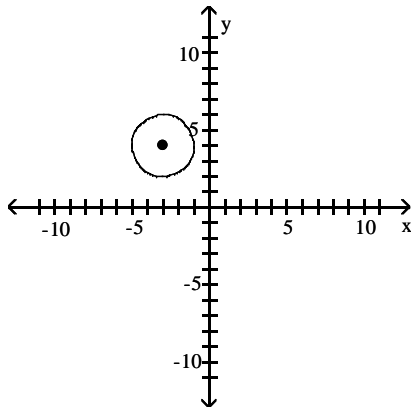

D)

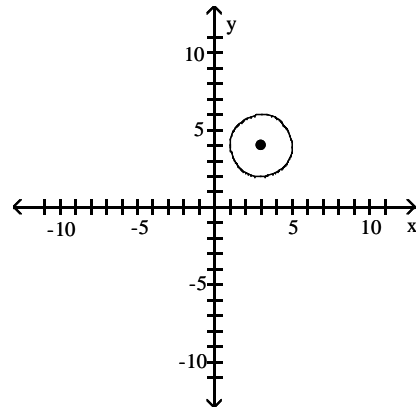

Graph the equation.

5) $x^2 + y^2 = 9$

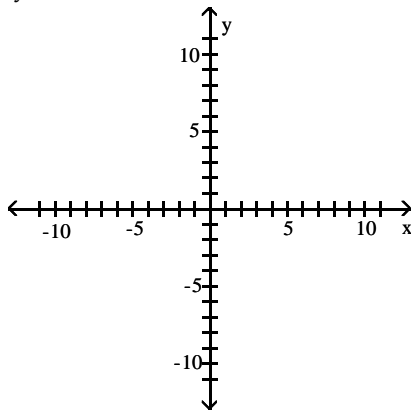

A)

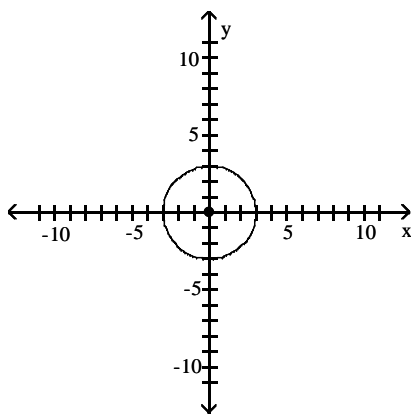

B)

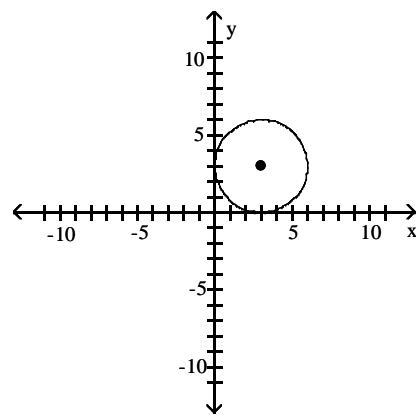

C)

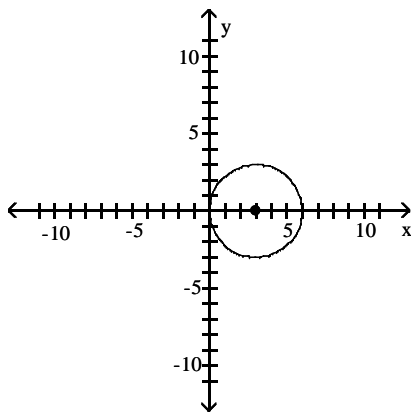

D)

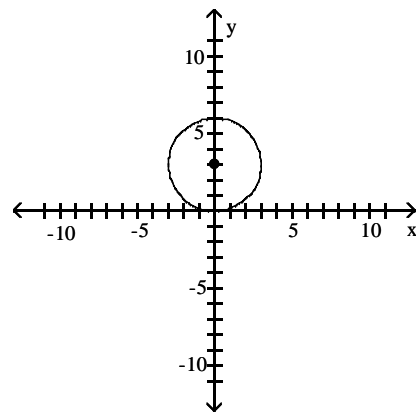

$$6) (x - 2)^2 + (y + 5)^2 = 9$$

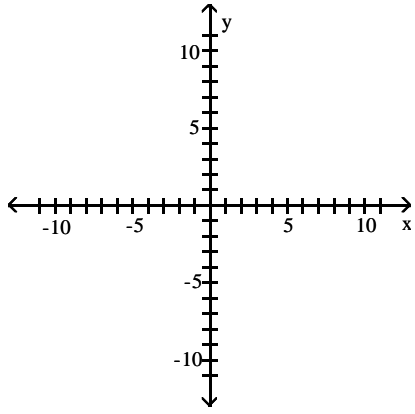

A)

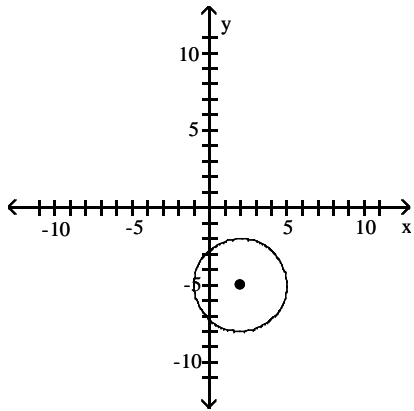

B)

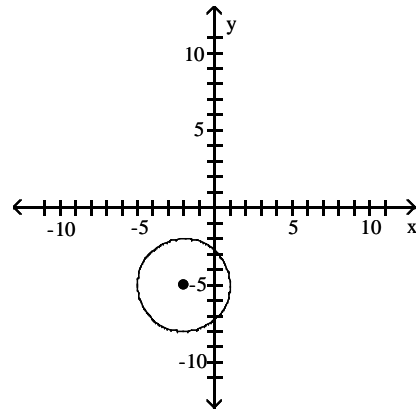

C)

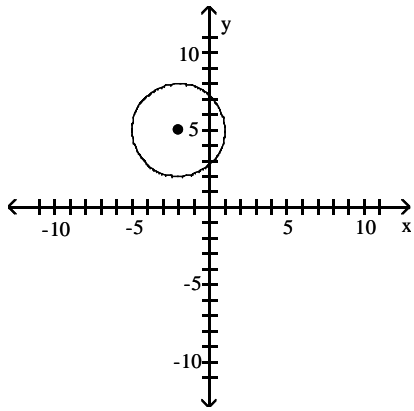

D)

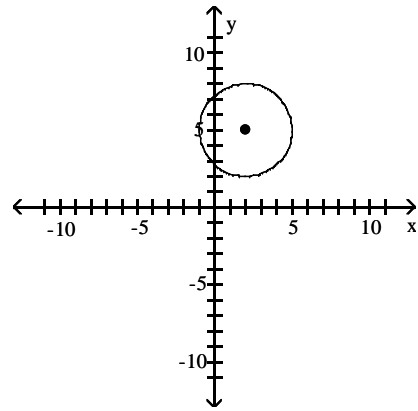

7) $x^2 + (y - 3)^2 = 36$

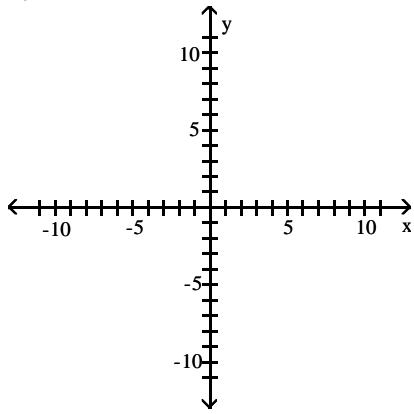

A)

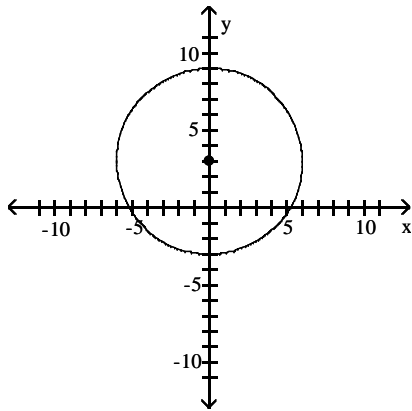

B)

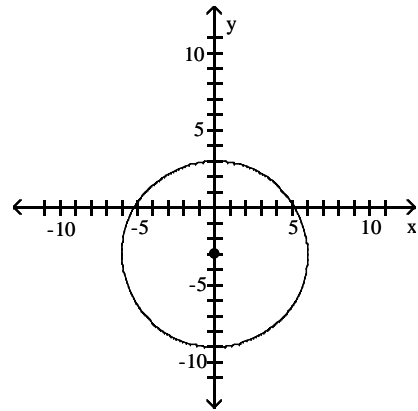

C)

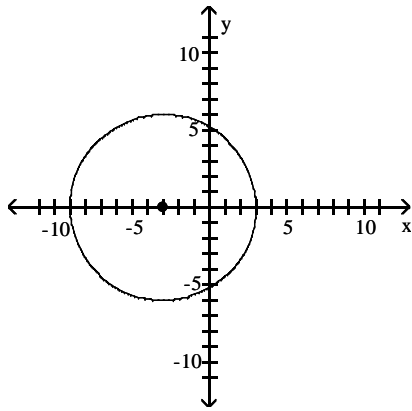

D)

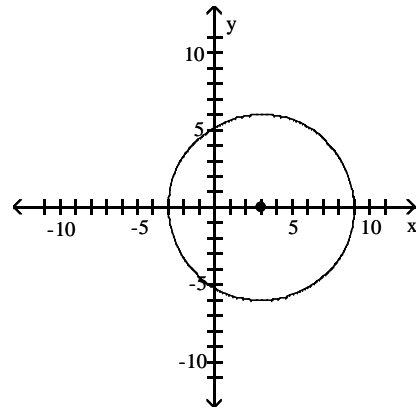

8) $(x - 2)^2 + y^2 = 25$

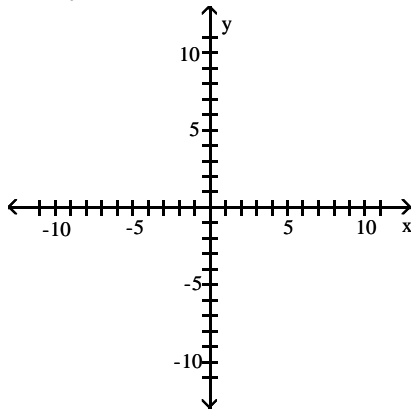

A)

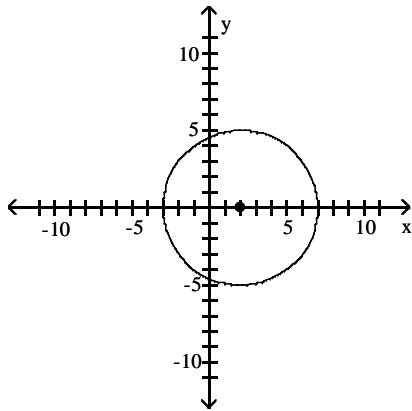

B)

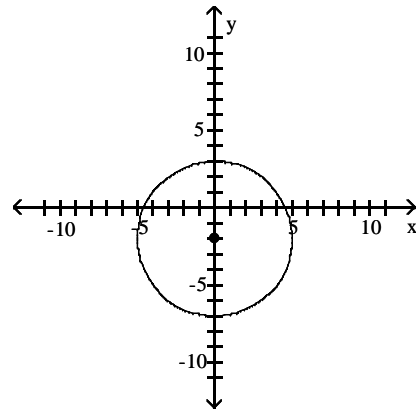

C)

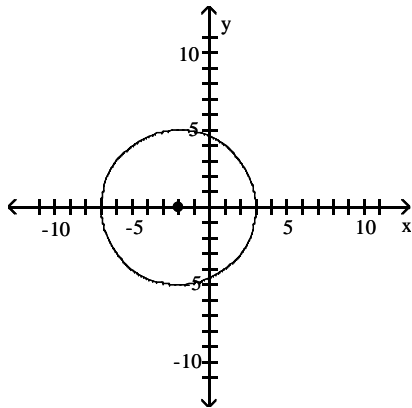

D)

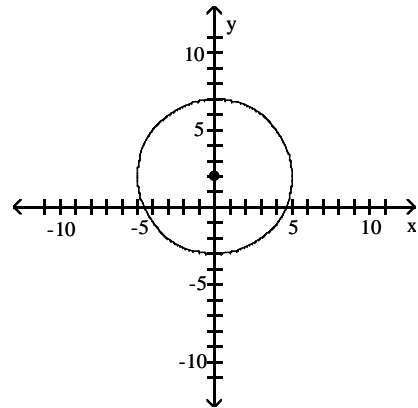

3 Work with the General Form of the Equation of a Circle

MULTIPLE CHOICE. Choose the one alternative that best completes the statement or answers the question.

Find the center (h, k) and radius r of the circle. Graph the circle.

1) $x^2 + y^2 - 10x - 2y + 17 = 0$

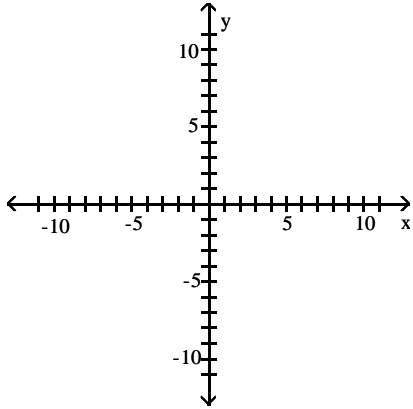

A) $(h, k) = (5, 1); r = 3$

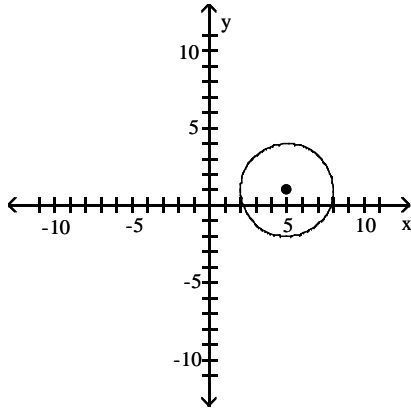

B) $(h, k) = (-5, -1); r = 3$

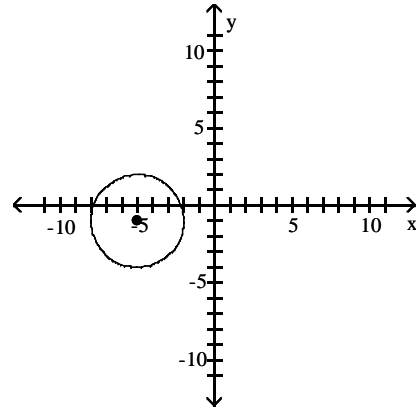

C) $(h, k) = (5, -1); r = 3$

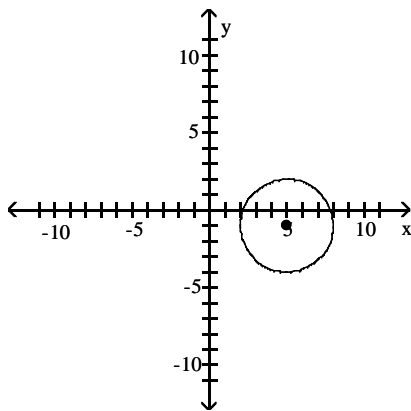

D) $(h, k) = (-5, 1); r = 3$

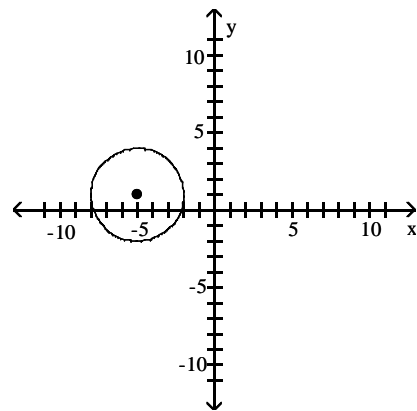

2) $x^2 + y^2 + 6x + 10y + 9 = 0$

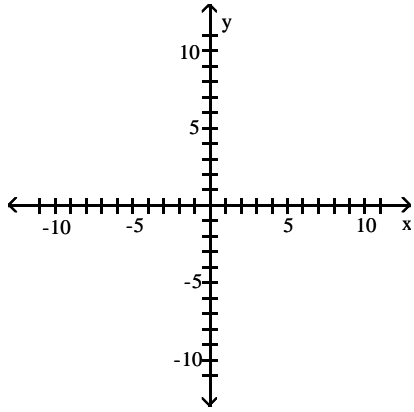

A) $(h, k) = (-3, -5); r = 5$

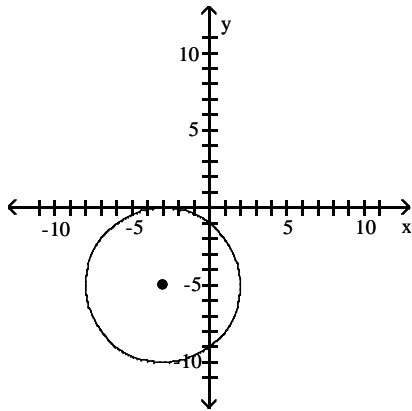

B) $(h, k) = (3, -5); r = 5$

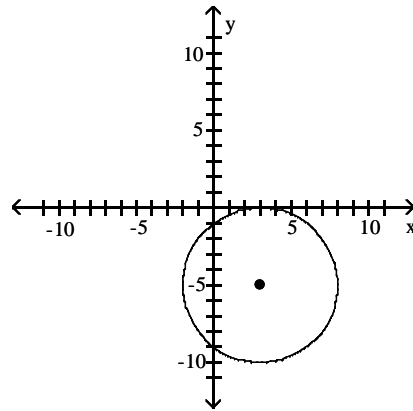

C) $(h, k) = (3, 5); r = 5$

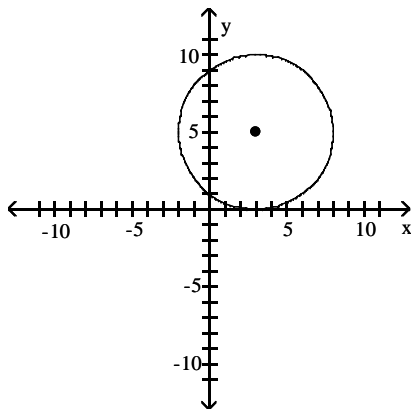

D) $(h, k) = (-3, 5); r = 5$

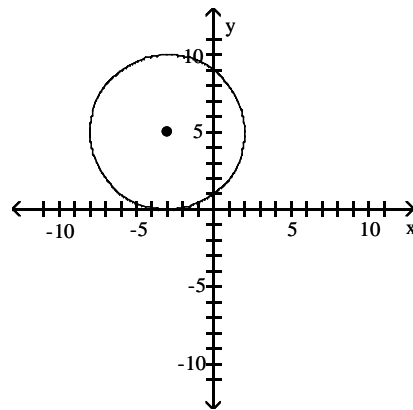

Find the center (h, k) and radius r of the circle with the given equation.

3) $x^2 + 8x + 16 + (y + 6)^2 = 64$

A) $(h, k) = (-4, -6); r = 8$

B) $(h, k) = (-6, -4); r = 8$

C) $(h, k) = (4, 6); r = 64$

D) $(h, k) = (6, 4); r = 64$

4) $x^2 - 6x + 9 + y^2 - 18y + 81 = 25$

A) $(h, k) = (3, 9); r = 5$

B) $(h, k) = (9, 3); r = 5$

C) $(h, k) = (-3, -9); r = 25$

D) $(h, k) = (-9, -3); r = 25$

5) $x^2 + y^2 - 12x - 4y + 40 = 4$

A) $(h, k) = (6, 2); r = 2$

C) $(h, k) = (-6, -2); r = 4$

B) $(h, k) = (2, 6); r = 2$

D) $(h, k) = (-2, -6); r = 4$

6) $x^2 + y^2 + 8x - 4y = -4$

A) $(h, k) = (-4, 2); r = 4$

C) $(h, k) = (4, -2); r = 16$

B) $(h, k) = (2, -4); r = 4$

D) $(h, k) = (-2, 4); r = 16$

7) $4x^2 + 4y^2 - 12x + 16y - 5 = 0$

A) $(h, k) = (\frac{3}{2}, -2); r = \frac{\sqrt{30}}{2}$

C) $(h, k) = (\frac{3}{2}, -2); r = \frac{3\sqrt{5}}{2}$

B) $(h, k) = (-\frac{3}{2}, 2); r = \frac{\sqrt{30}}{2}$

D) $(h, k) = (-\frac{3}{2}, 2); r = \frac{3\sqrt{5}}{2}$

Find the general form of the equation of the circle.

8) Center at the point $(-4, -3)$; containing the point $(-3, 3)$

A) $x^2 + y^2 + 8x + 6y - 12 = 0$

C) $x^2 + y^2 - 6x + 6y - 12 = 0$

B) $x^2 + y^2 + 6x + 8y - 17 = 0$

D) $x^2 + y^2 + 6x - 6y - 17 = 0$

9) Center at the point $(2, -3)$; containing the point $(5, -3)$

A) $x^2 + y^2 - 4x + 6y + 4 = 0$

C) $x^2 + y^2 - 4x + 6y + 22 = 0$

B) $x^2 + y^2 + 4x - 6y + 4 = 0$

D) $x^2 + y^2 + 4x - 6y + 22 = 0$

10) Center at the point $(-4, -2)$; tangent to x-axis

A) $x^2 + y^2 + 8x + 4y + 16 = 0$

C) $x^2 + y^2 - 8x - 4y + 16 = 0$

B) $x^2 + y^2 + 8x + 4y + 4 = 0$

D) $x^2 + y^2 + 8x + 4y + 24 = 0$

Solve the problem.

11) If a circle of radius 5 is made to roll along the x-axis, what is the equation for the path of the center of the circle?

A) $y = 5$

B) $y = 0$

C) $y = 10$

D) $x = 5$

12) Earth is represented on a map of the solar system so that its surface is a circle with the equation $x^2 + y^2 + 6x + 10y - 4191 = 0$. A weather satellite circles 0.7 units above the Earth with the center of its circular orbit at the center of the Earth. Find the general form of the equation for the orbit of the satellite on this map.

A) $x^2 + y^2 + 6x + 10y - 4282.49 = 0$

C) $x^2 + y^2 - 6x - 10y - 4282.49 = 0$

B) $x^2 + y^2 + 6x + 10y - 30.51 = 0$

D) $x^2 + y^2 + 6x + 10y + 33.51 = 0$

13) Find an equation of the line containing the centers of the two circles

$x^2 + y^2 - 6x - 2y + 9 = 0$ and

$x^2 + y^2 - 10x + 8y + 37 = 0$

A) $5x + 2y - 17 = 0$

B) $-3x - 8y - 17 = 0$

C) $5x - 2y - 17 = 0$

D) $-5x + 2y - 17 = 0$

14) A wildlife researcher is monitoring a black bear that has a radio telemetry collar with a transmitting range of 20 miles. The researcher is in a research station with her receiver and tracking the bear's movements. If we put the origin of a coordinate system at the research station, what is the equation of all possible locations of the bear where the transmitter would be at its maximum range?

A) $x^2 + y^2 = 400$

B) $x^2 + y^2 = 40$

C) $x^2 + y^2 = 20$

D) $x^2 - y^2 = 20$

15) If a satellite is placed in a circular orbit of 200 kilometers above the Earth, what is the equation of the path of the satellite if the origin is placed at the center of the Earth (the diameter of the Earth is approximately 12,740 kilometers)?

A) $x^2 + y^2 = 43,164,900$

B) $x^2 + y^2 = 40,000$

C) $x^2 + y^2 = 40,576,900$

D) $x^2 + y^2 = 167,443,600$

16) A power outage affected all homes and businesses within a 17 mi radius of the power station. If the power station is located 10 mi north of the center of town, find an equation of the circle consisting of the furthest points from the station affected by the power outage.

A) $x^2 + (y - 10)^2 = 289$

B) $x^2 + (y + 10)^2 = 289$

C) $x^2 + (y - 10)^2 = 17$

D) $x^2 + y^2 = 289$

17) A power outage affected all homes and businesses within a 2 mi radius of the power station. If the power station is located 4 mi west and 1 mi north of the center of town, find an equation of the circle consisting of the furthest points from the station affected by the power outage.

A) $(x + 4)^2 + (y - 1)^2 = 4$

B) $(x - 4)^2 + (y - 1)^2 = 4$

C) $(x + 4)^2 + (y + 1)^2 = 4$

D) $(x - 4)^2 + (y + 1)^2 = 4$

18) A Ferris wheel has a diameter of 240 feet and the bottom of the Ferris wheel is 13 feet above the ground. Find the equation of the wheel if the origin is placed on the ground directly below the center of the wheel, as illustrated.

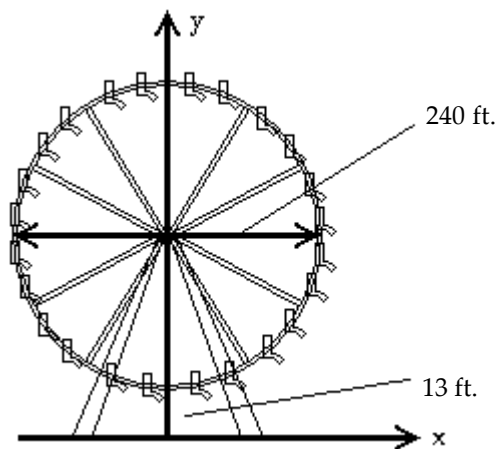

A) $x^2 + (y - 133)^2 = 14,400$

B) $x^2 + (y - 120)^2 = 14,400$

C) $x^2 + (y - 120)^2 = 57,600$

D) $x^2 + y^2 = 14,400$

2.4 Variation

1 Construct a Model Using Direct Variation

MULTIPLE CHOICE. Choose the one alternative that best completes the statement or answers the question.

Write a general formula to describe the variation.

1) v varies directly with t ; $v = 6$ when $t = 18$

A) $v = \frac{1}{3}t$

B) $v = 3t$

C) $v = \frac{6}{18t}$

D) $v = \frac{18}{6t}$

2) A varies directly with t^2 ; $A = 12$ when $t = 2$

A) $A = 3t^2$

B) $A = 6t^2$

C) $A = \frac{3}{t^2}$

D) $A = \frac{6}{t^2}$

3) z varies directly with the sum of the squares of x and y ; $z = 35$ when $x = 21$ and $y = 28$

A) $z = \frac{1}{35}(x^2 + y^2)$

B) $z^2 = x^2 + y^2$

C) $z = \frac{1}{1225}(x^2 + y^2)$

D) $z = \frac{1}{70}(x^2 + y^2)$

If y varies directly as x , write a general formula to describe the variation.

4) $y = 3$ when $x = 15$

A) $y = \frac{1}{5}x$

B) $y = 5x$

C) $y = x + 12$

D) $y = \frac{1}{3}x$

5) $y = 28$ when $x = 12$

A) $y = \frac{7}{3}x$

B) $y = \frac{3}{7}x$

C) $y = x + 16$

D) $y = 4x$

6) $y = 6$ when $x = \frac{1}{7}$

A) $y = 42x$

B) $y = \frac{1}{42}x$

C) $y = x + \frac{41}{7}$

D) $y = \frac{1}{6}x$

7) $y = 3$ when $x = 0.6$

A) $y = 5x$

B) $y = 0.6x$

C) $y = x + 2.4$

D) $y = 0.2x$

8) $y = 0.9$ when $x = 1.8$

A) $y = 0.5x$

B) $y = 0.9x$

C) $y = x - 0.9$

D) $y = 2x$

Write a general formula to describe the variation.

9) The volume V of a right circular cone varies directly with the square of its base radius r and its height h . The constant of proportionality is $\frac{1}{3}\pi$.

A) $V = \frac{1}{3}\pi r^2 h$

B) $V = \frac{1}{3}\pi r h$

C) $V = \frac{1}{3}r^2 h$

D) $V = \frac{1}{3}\pi r^2 h^2$

10) The surface area S of a right circular cone varies directly as the radius r times the square root of the sum of the squares of the base radius r and the height h . The constant of proportionality is π .

A) $S = \pi r \sqrt{r^2 + h^2}$

B) $S = \pi r \sqrt{r^2 h^2}$

C) $S = \pi \sqrt{r^2 + h^2}$

D) $S = \pi r \sqrt{r^2 h}$

Solve the problem.

11) In simplified form, the period of vibration P for a pendulum varies directly as the square root of its length L . If P is 0.5 sec. when L is 4 in., what is the period when the length is 64 in.?

A) 2 sec

B) 16 sec

C) 32 sec

D) 256 sec

12) The amount of water used to take a shower is directly proportional to the amount of time that the shower is in use. A shower lasting 19 minutes requires 9.5 gallons of water. Find the amount of water used in a shower lasting 5 minutes.

A) 2.5 gal

B) 36.1 gal

C) 10 gal

D) 1.9 gal

13) If the resistance in an electrical circuit is held constant, the amount of current flowing through the circuit is directly proportional to the amount of voltage applied to the circuit. When 5 volts are applied to a circuit, 50 milliamperes (mA) of current flow through the circuit. Find the new current if the voltage is increased to 13 volts.

A) 130 mA

B) 65 mA

C) 117 mA

D) 140 mA

14) The amount of gas that a helicopter uses is directly proportional to the number of hours spent flying. The helicopter flies for 2 hours and uses 16 gallons of fuel. Find the number of gallons of fuel that the helicopter uses to fly for 6 hours.

A) 48 gal

B) 12 gal

C) 54 gal

D) 56 gal

15) The distance that an object falls when it is dropped is directly proportional to the square of the amount of time since it was dropped. An object falls 156.8 meters in 4 seconds. Find the distance the object falls in 5 seconds.

A) 245 m

B) 49 m

C) 196 m

D) 20 m

2 Construct a Model Using Inverse Variation

MULTIPLE CHOICE. Choose the one alternative that best completes the statement or answers the question.

Write a general formula to describe the variation.

1) A varies inversely with x^2 ; $A = 10$ when $x = 2$

A) $A = \frac{40}{x^2}$

B) $A = \frac{20}{x^2}$

C) $A = \frac{5}{2}x^2$

D) $A = 20x^2$

Write an equation that expresses the relationship. Use k as the constant of variation.

2) d varies inversely as v .

A) $d = \frac{k}{v}$

B) $d = \frac{v}{k}$

C) $d = kv$

D) $kd = v$

3) s varies inversely as the square of v .

A) $s = \frac{k}{v^2}$

B) $s = \frac{v^2}{k}$

C) $s = \frac{k}{\sqrt{v}}$

D) $s = \frac{\sqrt{v}}{k}$

If y varies inversely as x , write a general formula to describe the variation.

4) $y = 4$ when $x = 7$

A) $y = \frac{28}{x}$

B) $y = \frac{4}{7}x$

C) $y = \frac{x}{28}$

D) $y = \frac{1}{28x}$

5) $y = 20$ when $x = 8$

A) $y = \frac{160}{x}$

B) $y = \frac{5}{2}x$

C) $y = \frac{x}{160}$

D) $y = \frac{1}{160x}$

6) $y = 35$ when $x = \frac{1}{7}$

A) $y = \frac{5}{x}$

B) $y = 245x$

C) $y = \frac{x}{5}$

D) $y = \frac{1}{5x}$

7) $y = \frac{1}{7}$ when $x = 21$

A) $y = \frac{3}{x}$

B) $y = \frac{1}{147}x$

C) $y = \frac{x}{3}$

D) $y = \frac{1}{3x}$

8) $y = 0.8$ when $x = 0.4$

A) $y = \frac{0.32}{x}$

B) $y = 2x$

C) $y = 3.125x$

D) $y = \frac{3.125}{x}$

Solve the problem.

9) x varies inversely as v , and $x = 54$ when $v = 8$. Find x when $v = 72$.

A) $x = 6$

B) $x = 64$

C) $x = 48$

D) $x = 9$

10) x varies inversely as y^2 , and $x = 3$ when $y = 20$. Find x when $y = 4$.

A) $x = 75$

B) $x = 45$

C) $x = 48$

D) $x = 5$

11) When the temperature stays the same, the volume of a gas is inversely proportional to the pressure of the gas. If a balloon is filled with 295 cubic inches of a gas at a pressure of 14 pounds per square inch, find the new pressure of the gas if the volume is decreased to 59 cubic inches.

A) 70 psi

B) $\frac{59}{14}$ psi

C) 56 psi

D) 65 psi

12) The amount of time it takes a swimmer to swim a race is inversely proportional to the average speed of the swimmer. A swimmer finishes a race in 100 seconds with an average speed of 3 feet per second. Find the average speed of the swimmer if it takes 75 seconds to finish the race.

A) 4 ft/sec

B) 5 ft/sec

C) 6 ft/sec

D) 3 ft/sec

13) If the force acting on an object stays the same, then the acceleration of the object is inversely proportional to its mass. If an object with a mass of 12 kilograms accelerates at a rate of 7 meters per second per second (m/sec^2) by a force, find the rate of acceleration of an object with a mass of 3 kilograms that is pulled by the same force.

A) $28 m/sec^2$

B) $\frac{7}{4} m/sec^2$

C) $21 m/sec^2$

D) $24 m/sec^2$

- 14) If the voltage, V , in an electric circuit is held constant, the current, I , is inversely proportional to the resistance, R . If the current is 80 milliamperes (mA) when the resistance is 5 ohms, find the current when the resistance is 20 ohms.
- A) 20 mA B) 320 mA C) 316 mA D) 100 mA
- 15) While traveling at a constant speed in a car, the centrifugal acceleration passengers feel while the car is turning is inversely proportional to the radius of the turn. If the passengers feel an acceleration of 15 feet per second per second (ft/sec^2) when the radius of the turn is 80 feet, find the acceleration the passengers feel when the radius of the turn is 240 feet.
- A) $5 \text{ ft}/\text{sec}^2$ B) $6 \text{ ft}/\text{sec}^2$ C) $7 \text{ ft}/\text{sec}^2$ D) $8 \text{ ft}/\text{sec}^2$

3 Construct a Model Using Joint or Combined Variation

MULTIPLE CHOICE. Choose the one alternative that best completes the statement or answers the question.

Write a general formula to describe the variation.

- 1) The square of G varies directly with the cube of x and inversely with the square of y ; $G = 4$ when $x = 2$ and $y = 6$

A) $G^2 = 72 \frac{x^3}{y^2}$ B) $G^2 = 12 \frac{x^3}{y^2}$ C) $G^2 = \frac{32}{9} \frac{y^3}{x^2}$ D) $G^2 = \frac{1}{18} (x^3 + y^2)$

- 2) R varies directly with g and inversely with the square of h ; $R = 3$ when $g = 3$ and $h = 5$.

A) $R = 25 \frac{g}{h^2}$ B) $R = 5 \frac{g}{h^2}$ C) $R = 5 \frac{h^2}{g}$ D) $R = 25gh^2$

- 3) z varies jointly as the cube root of x and the cube of y ; $z = 5$ when $x = 125$ and $y = 3$.

A) $z = \frac{1}{27} \sqrt[3]{xy^3}$ B) $z = 27 \sqrt[3]{xy^3}$ C) $z = 27 \frac{\sqrt[3]{x}}{y^3}$ D) $z = \frac{1}{27} \frac{\sqrt[3]{x}}{y^3}$

- 4) The centrifugal force F of an object speeding around a circular course varies directly as the product of the object's mass m and the square of its velocity v and inversely as the radius of the turn r .

A) $F = \frac{kmv^2}{r}$ B) $F = \frac{kmv}{r}$ C) $F = \frac{km^2v}{r}$ D) $F = \frac{kmr}{v^2}$

- 5) The safety load λ of a beam with a rectangular cross section that is supported at each end varies directly as the product of the width W and the square of the depth D and inversely as the length L of the beam between the supports.

A) $\lambda = \frac{kWD^2}{L}$ B) $\lambda = \frac{kWD}{L}$ C) $\lambda = \frac{k(W + D^2)}{L}$ D) $\lambda = \frac{kL}{WD^2}$

- 6) The illumination I produced on a surface by a source of light varies directly as the candlepower c of the source and inversely as the square of the distance d between the source and the surface.

A) $I = \frac{kc}{d^2}$ B) $I = \frac{kc^2}{d^2}$ C) $I = kcd^2$ D) $I = \frac{kd^2}{c}$

Solve the problem.

- 7) The volume V of a given mass of gas varies directly as the temperature T and inversely as the pressure P . A measuring device is calibrated to give $V = 234 \text{ in}^3$ when $T = 180^\circ$ and $P = 10 \text{ lb/in}^2$. What is the volume on this device when the temperature is 270° and the pressure is 20 lb/in^2 ?
- A) $V = 175.5 \text{ in}^3$ B) $V = 13.5 \text{ in}^3$ C) $V = 195.5 \text{ in}^3$ D) $V = 155.5 \text{ in}^3$
- 8) The time in hours it takes a satellite to complete an orbit around the earth varies directly as the radius of the orbit (from the center of the earth) and inversely as the orbital velocity. If a satellite completes an orbit 650 miles above the earth in 8 hours at a velocity of 33,000 mph, how long would it take a satellite to complete an orbit if it is at 1200 miles above the earth at a velocity of 35,000 mph? (Use 3960 miles as the radius of the earth.)
- A) 8.44 hr B) 13.93 hr C) 1.96 hr D) 84.43 hr
- 9) The pressure of a gas varies jointly as the amount of the gas (measured in moles) and the temperature and inversely as the volume of the gas. If the pressure is 750 kiloPascals (kPa) when the number of moles is 8, the temperature is 250° Kelvin, and the volume is 960 cc, find the pressure when the number of moles is 6, the temperature is 290° K, and the volume is 720 cc.
- A) 870 kPa B) 810 kPa C) 1740 kPa D) 1860 kPa
- 10) Body-mass index, or BMI, takes both weight and height into account when assessing whether an individual is underweight or overweight. BMI varies directly as one's weight, in pounds, and inversely as the square of one's height, in inches. In adults, normal values for the BMI are between 20 and 25. A person who weighs 176 pounds and is 68 inches tall has a BMI of 26.76. What is the BMI, to the nearest tenth, for a person who weighs 120 pounds and who is 65 inches tall?
- A) 20 B) 20.3 C) 19.6 D) 19.3
- 11) The amount of paint needed to cover the walls of a room varies jointly as the perimeter of the room and the height of the wall. If a room with a perimeter of 55 feet and 6-foot walls requires 3.3 quarts of paint, find the amount of paint needed to cover the walls of a room with a perimeter of 50 feet and 6-foot walls.
- A) 3 qt B) 300 qt C) 30 qt D) 6 qt
- 12) The power that a resistor must dissipate is jointly proportional to the square of the current flowing through the resistor and the resistance of the resistor. If a resistor needs to dissipate 108 watts of power when 6 amperes of current is flowing through the resistor whose resistance is 3 ohms, find the power that a resistor needs to dissipate when 2 amperes of current are flowing through a resistor whose resistance is 7 ohms.
- A) 28 watts B) 14 watts C) 98 watts D) 84 watts
- 13) While traveling in a car, the centrifugal force a passenger experiences as the car drives in a circle varies jointly as the mass of the passenger and the square of the speed of the car. If a passenger experiences a force of 345.6 newtons (N) when the car is moving at a speed of 80 kilometers per hour and the passenger has a mass of 60 kilograms, find the force a passenger experiences when the car is moving at 20 kilometers per hour and the passenger has a mass of 100 kilograms.
- A) 36 N B) 40 N C) 32 N D) 44 N

14) The amount of simple interest earned on an investment over a fixed amount of time is jointly proportional to the principle invested and the interest rate. A principle investment of \$4500.00 with an interest rate of 5% earned \$450.00 in simple interest. Find the amount of simple interest earned if the principle is \$1500.00 and the interest rate is 7%.

A) \$210.00

B) \$21,000.00

C) \$150.00

D) \$630.00

15) The voltage across a resistor is jointly proportional to the resistance of the resistor and the current flowing through the resistor. If the voltage across a resistor is 35 volts (V) for a resistor whose resistance is 7 ohms and when the current flowing through the resistor is 5 amperes, find the voltage across a resistor whose resistance is 3 ohms and when the current flowing through the resistor is 4 amperes.

A) 12 V

B) 28 V

C) 20 V

D) 15 V

Ch. 2 Graphs

Answer Key

2.1 Intercepts; Symmetry; Graphing Key Equations

1 Find Intercepts Algebraically from an Equation

- 1) A
- 2) A
- 3) A
- 4) A
- 5) A
- 6) A
- 7) A
- 8) A
- 9) A
- 10) A
- 11) A
- 12) A
- 13) A

2 Test an Equation for Symmetry with Respect to (a) the x-Axis, (b) the y-Axis, and (c) the Origin

- 1) A
- 2) A
- 3) A
- 4) A
- 5) A
- 6) A
- 7) A
- 8) A
- 9) A
- 10) A
- 11) A
- 12) A
- 13) A
- 14) E
- 15) A
- 16) A
- 17) A
- 18) D
- 19) D
- 20) E
- 21) A
- 22) A
- 23) A
- 24) E
- 25) A
- 26) E
- 27) A
- 28) A

3 Know How to Graph Key Equations

- 1) A
- 2) A
- 3) A
- 4) A

2.2 Lines

1 Calculate and Interpret the Slope of a Line

- 1) A
- 2) A
- 3) A
- 4) A
- 5) A
- 6) A
- 7) A
- 8) A
- 9) D
- 10) A

2 Graph Lines Given a Point and a Slope

- 1) A
- 2) A
- 3) A
- 4) A
- 5) A
- 6) A
- 7) A
- 8) A
- 9) A
- 10) A
- 11) A
- 12) A
- 13) A
- 14) A

3 Find the Equation of a Vertical Line

- 1) A
- 2) A
- 3) A
- 4) A
- 5) A

4 Use the Point-Slope Form of a Line; Identify Horizontal Lines

- 1) A
- 2) A
- 3) A
- 4) A
- 5) A
- 6) A

5 Find the Equation of a Line Given Two Points

- 1) A
- 2) A
- 3) A
- 4) A
- 5) A
- 6) A
- 7) A
- 8) A
- 9) A
- 10) A
- 11) A
- 12) A
- 13) A

- 14) A
- 15) A
- 16) A

6 Write the Equation of a Line in Slope-Intercept Form

- 1) A
- 2) A
- 3) A
- 4) A
- 5) A
- 6) A
- 7) A
- 8) A
- 9) A
- 10) A
- 11) A
- 12) A
- 13) A

7 Identify the Slope and y-Intercept of a Line from its Equation

- 1) A
- 2) A
- 3) A
- 4) A
- 5) A
- 6) A
- 7) A
- 8) A
- 9) A
- 10) A
- 11) A
- 12) A

8 Graph Lines Written in General Form Using Intercepts

- 1) A
- 2) A
- 3) A
- 4) A
- 5) A
- 6) A
- 7) A

9 Find Equations of Parallel Lines

- 1) A
- 2) A
- 3) A
- 4) A
- 5) A
- 6) A
- 7) A
- 8) A

10 Find Equations of Perpendicular Lines

- 1) A
- 2) A
- 3) A
- 4) A
- 5) A
- 6) A

- 7) A
- 8) A
- 9) A
- 10) A
- 11) B
- 12) B
- 13) A

2.3 Circles

1 Write the Standard Form of the Equation of a Circle

- 1) A
- 2) A
- 3) A
- 4) A
- 5) A
- 6) A
- 7) A
- 8) A
- 9) A
- 10) A
- 11) A
- 12) A
- 13) A
- 14) A
- 15) A
- 16) A
- 17) A

2 Graph a Circle by Hand and by Using a Graphing Utility

- 1) A
- 2) A
- 3) A
- 4) A
- 5) A
- 6) A
- 7) A
- 8) A

3 Work with the General Form of the Equation of a Circle

- 1) A
- 2) A
- 3) A
- 4) A
- 5) A
- 6) A
- 7) A
- 8) A
- 9) A
- 10) A
- 11) A
- 12) A
- 13) A
- 14) A
- 15) A
- 16) A
- 17) A
- 18) A

2.4 Variation

1 Construct a Model Using Direct Variation

- 1) A
- 2) A
- 3) A
- 4) A
- 5) A
- 6) A
- 7) A
- 8) A
- 9) A
- 10) A
- 11) A
- 12) A
- 13) A
- 14) A
- 15) A

2 Construct a Model Using Inverse Variation

- 1) A
- 2) A
- 3) A
- 4) A
- 5) A
- 6) A
- 7) A
- 8) A
- 9) A
- 10) A
- 11) A
- 12) A
- 13) A
- 14) A
- 15) A

3 Construct a Model Using Joint or Combined Variation

- 1) A
- 2) A
- 3) A
- 4) A
- 5) A
- 6) A
- 7) A
- 8) A
- 9) A
- 10) A
- 11) A
- 12) A
- 13) A
- 14) A
- 15) A