

**TEST BANK**



**SULLIVAN**



**COLLEGE ALGEBRA**

NINTH EDITION

## Ch. 2 Graphs

### 2.1 The Distance and Midpoint Formulas

#### 1 Rectangular Coordinates

MULTIPLE CHOICE. Choose the one alternative that best completes the statement or answers the question.

Name the quadrant in which the point is located.

1) (16, 12)

A) I

B) II

C) III

D) IV

2) (-8, 15)

A) I

B) II

C) III

D) IV

3) (-15, -5)

A) I

B) II

C) III

D) IV

4) (3, -18)

A) I

B) II

C) III

D) IV

Identify the points in the graph for the ordered pairs.

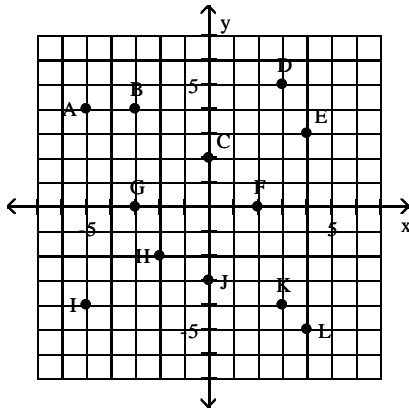

5) (0, 2), (4, 3)

A) C and E

B) B and C

C) C and K

D) F and E

6) (-5, -4), (0, -3)

A) A and J

B) G and I

C) I and J

D) A and G

7) (-3, 4), (2, 0), (4, -5)

A) F, K, and L

B) B, C, and L

C) B, F, and L

D) A, B, and F

8) (3, 5), (-3, 0)

A) D and G

B) I and G

C) L and J

D) D and J

Give the coordinates of the points shown on the graph.

9)

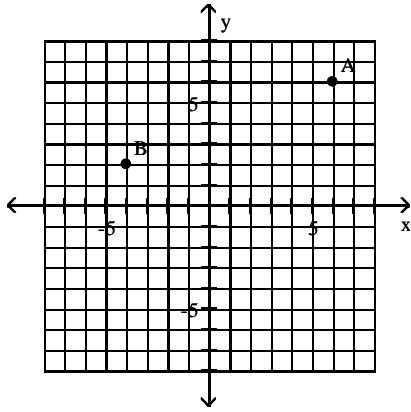

- A)  $A = (6, 28)$ ,  $B = (2, -4)$
- C)  $A = (6, 6)$ ,  $B = (-4, 2)$

- B)  $A = (6, 6)$ ,  $B = (2, -4)$
- D)  $A = (6, 2)$ ,  $B = (6, 2)$

10)

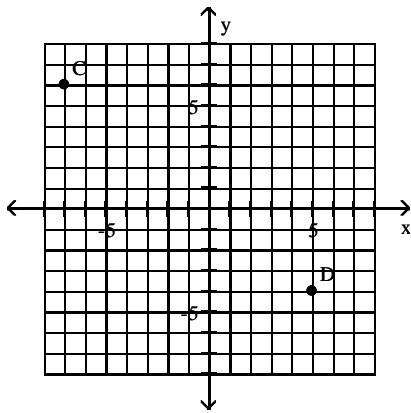

- A)  $C = (6, -7)$ ,  $D = (-4, 5)$
- C)  $C = (-7, -4)$ ,  $D = (6, -4)$

- B)  $C = (-7, 6)$ ,  $D = (5, -4)$
- D)  $C = (-7, 6)$ ,  $D = (-4, 5)$

11)

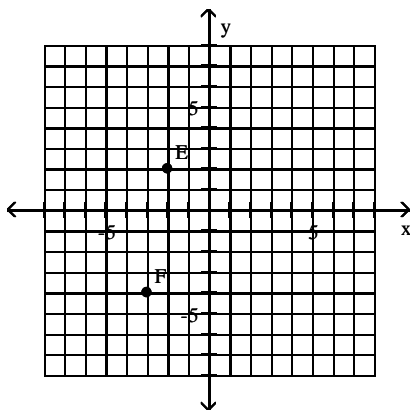

- A)  $E = (-2, 2)$ ,  $F = (-3, -4)$
- C)  $E = (-3, -4)$ ,  $F = (-2, 2)$

- B)  $E = (2, -2)$ ,  $F = (-4, -3)$
- D)  $E = (-2, -4)$ ,  $F = (2, -4)$

12)

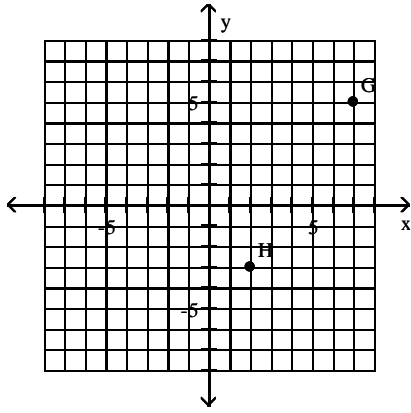

- A)  $G = (7, 5)$ ,  $H = (-3, 2)$   
C)  $G = (7, 5)$ ,  $H = (2, -3)$

- B)  $G = (5, 7)$ ,  $H = (-3, 2)$   
D)  $G = (7, -3)$ ,  $H = (5, -3)$

Plot the point in the  $xy$ -plane. Tell in which quadrant or on what axis the point lies.

13)  $(1, 3)$

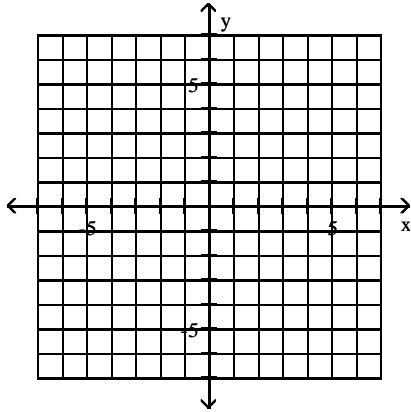

A)

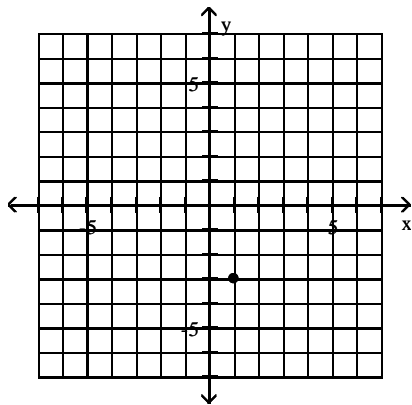

Quadrant IV

B)

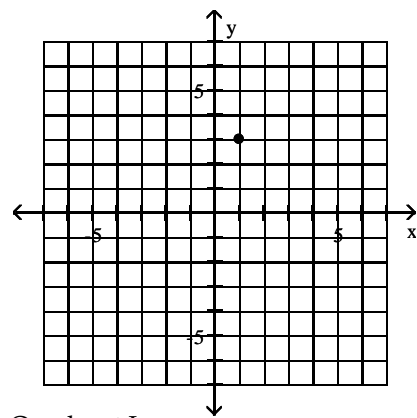

Quadrant I

C)

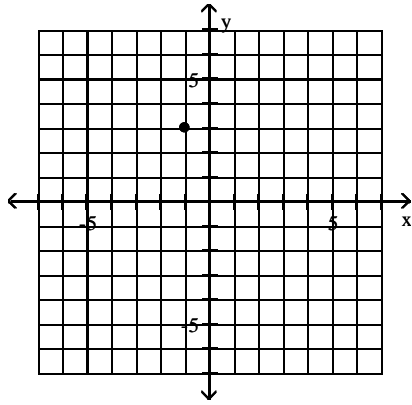

Quadrant II

D)

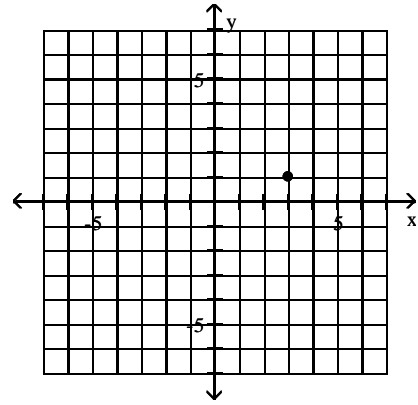

Quadrant I

14)  $(-4, 5)$

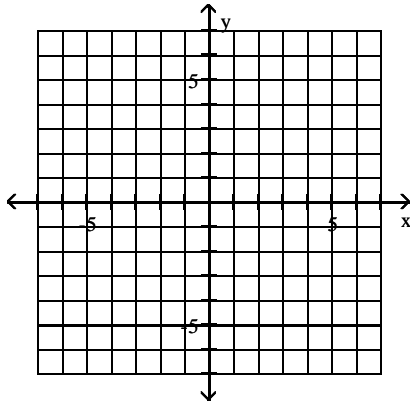

A)

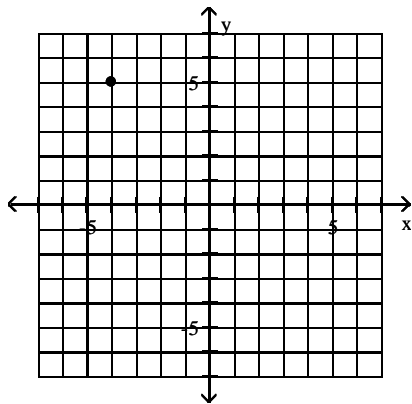

Quadrant II

B)

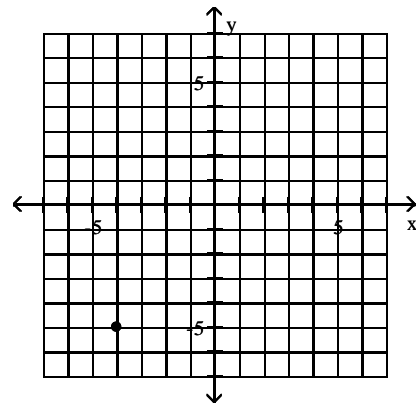

Quadrant III

C)

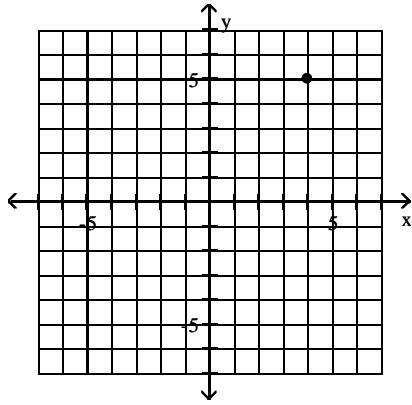

Quadrant I

D)

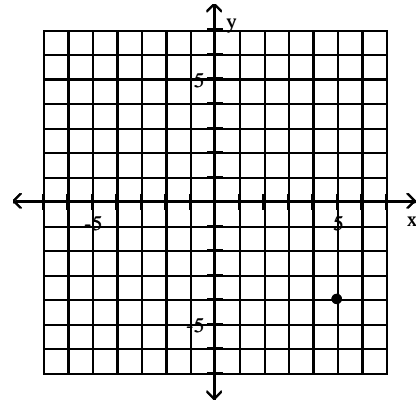

Quadrant IV

15)  $(4, -2)$

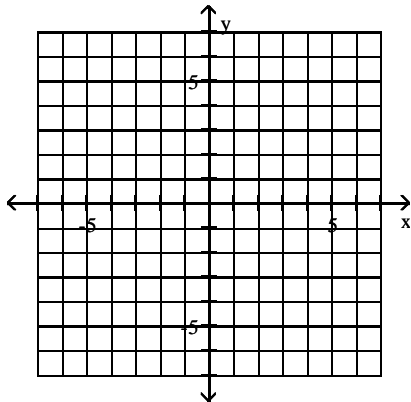

A)

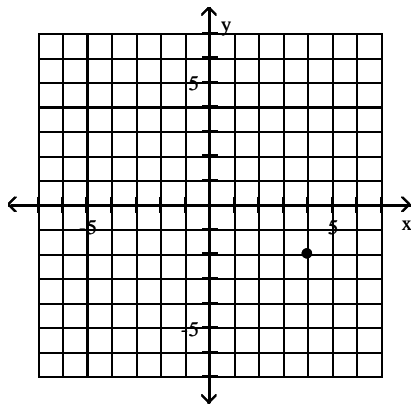

Quadrant IV

B)

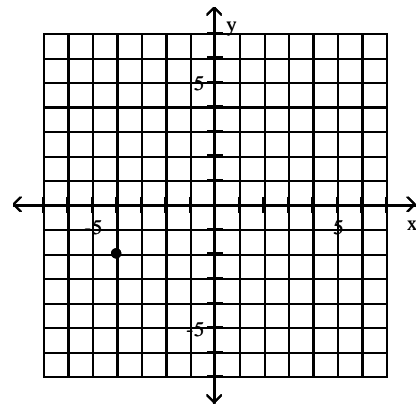

Quadrant III

C)

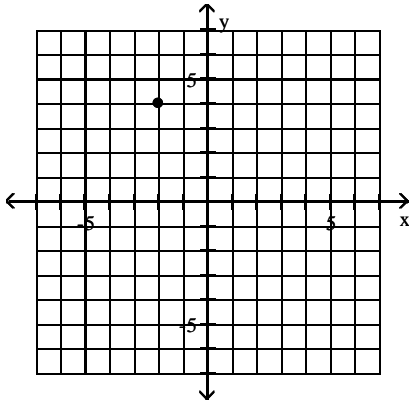

Quadrant II

D)

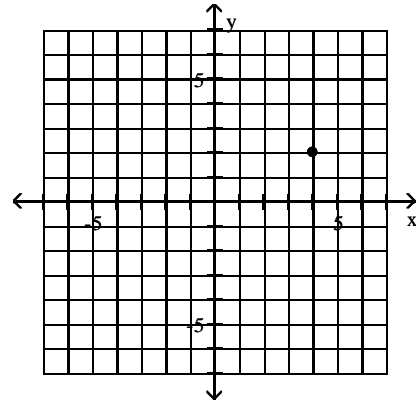

Quadrant I

16)  $(-4, -5)$

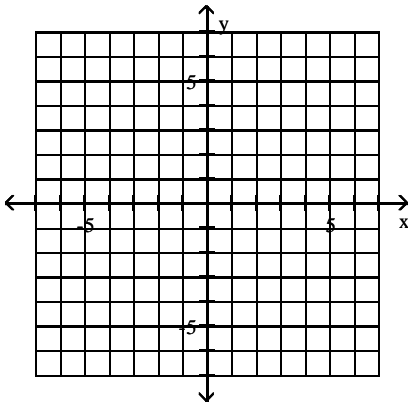

A)

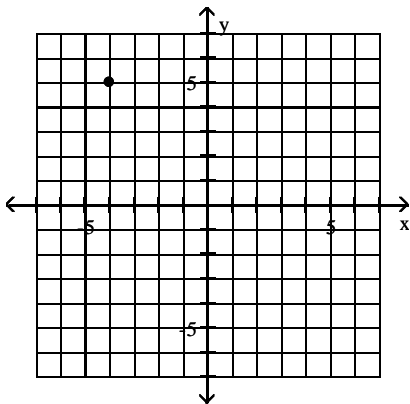

Quadrant II

B)

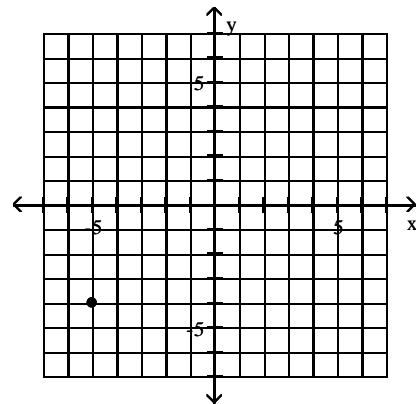

Quadrant III

C)

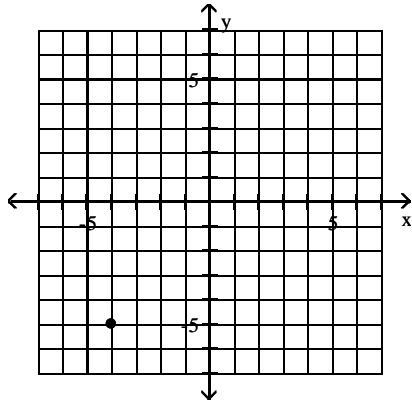

Quadrant III

D)

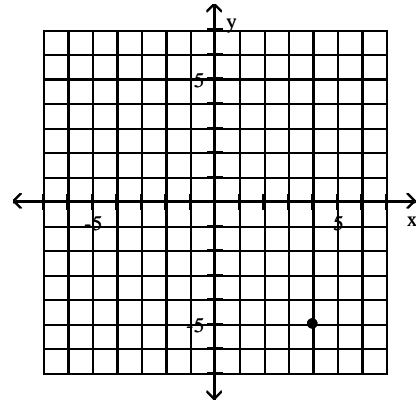

Quadrant IV

17) (0, -3)

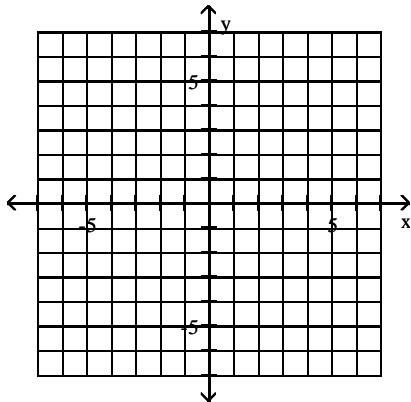

A)

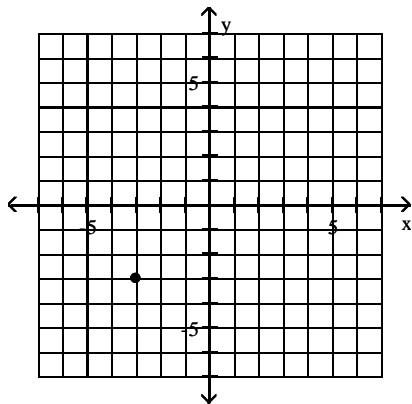

Quadrant II

B)

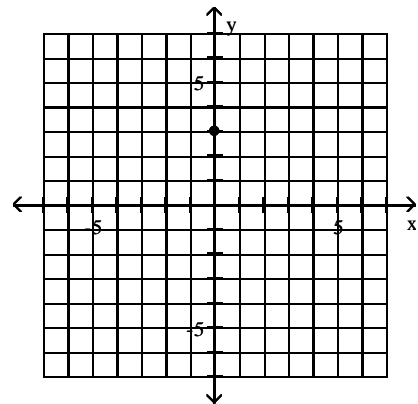

y-axis



C)

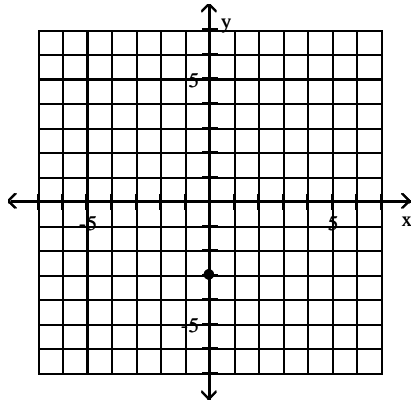

y-axis

D)

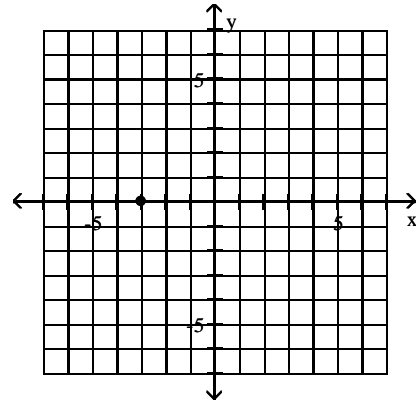

x-axis

18)  $(-4, 0)$

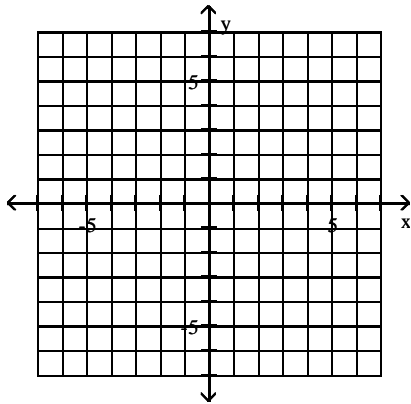

A)

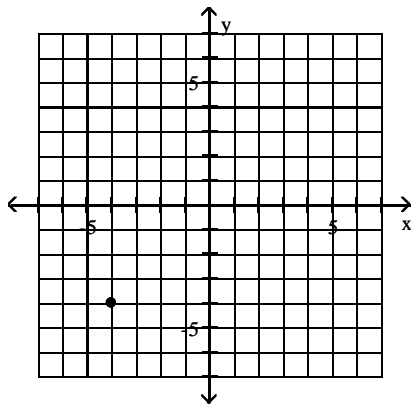

Quadrant II

B)

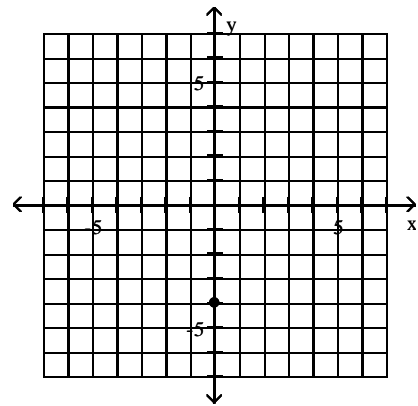

y-axis

C)

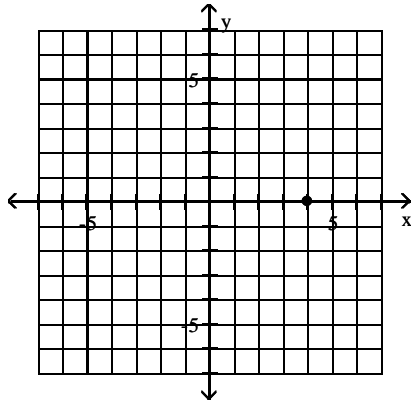

x-axis

D)

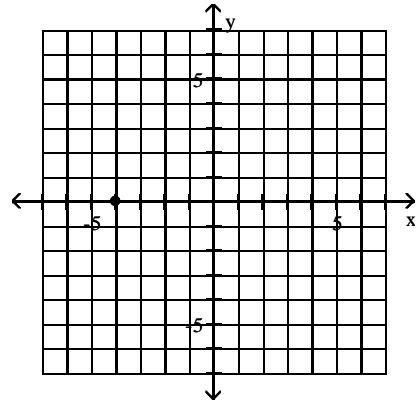

x-axis

## 2 Use the Distance Formula

MULTIPLE CHOICE. Choose the one alternative that best completes the statement or answers the question.

Find the distance  $d(P_1, P_2)$  between the points  $P_1$  and  $P_2$ .

1)

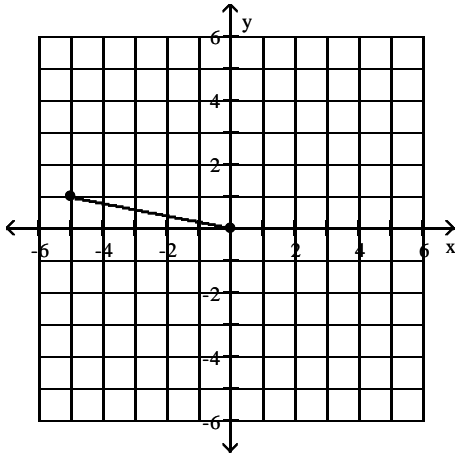

A)  $\sqrt{26}$

B) 7

C) 5

D)  $\sqrt{6}$

2)

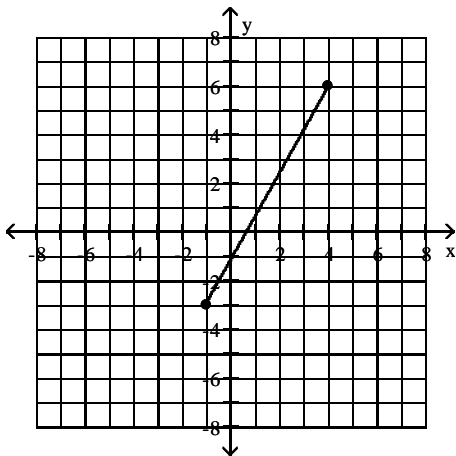

A)  $\sqrt{106}$

B) 4

C) 45

D)  $2\sqrt{14}$

3)

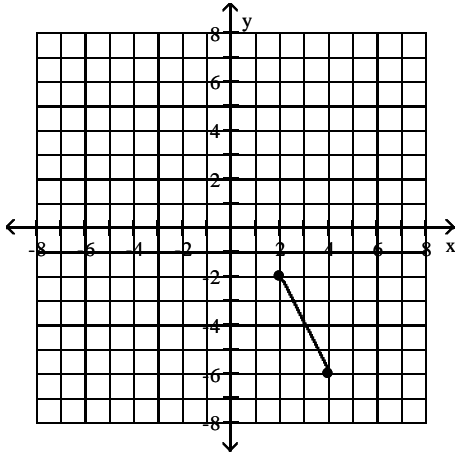

A)  $2\sqrt{5}$

B) 12

C) 6

D)  $12\sqrt{3}$

4)

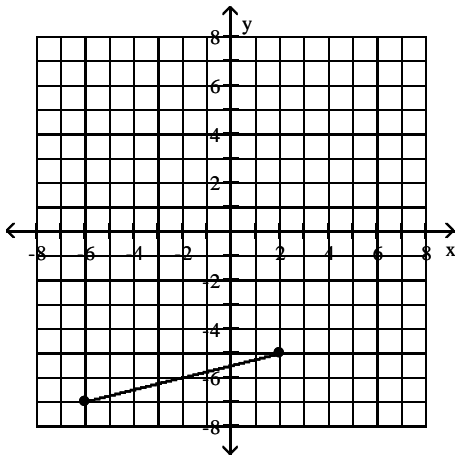

A) 60

B)  $2\sqrt{17}$

C)  $60\sqrt{15}$

D) 6

5)  $P_1 = (3, 3); P_2 = (3, -3)$

A) 5

B)  $\sqrt{6}$

C) 7

D) 6

6)  $P_1 = (2, 2); P_2 = (-10, -3)$

A) 169

B) 26

C) 14

D) 13

7)  $P_1 = (0, 4); P_2 = (-10, 4)$

A) 100

B) 10

C) 4

D)  $2\sqrt{29}$

8)  $P_1 = (0, 0); P_2 = (-8, -9)$

A) 145

B) 17

C)  $\sqrt{145}$

D)  $6i\sqrt{2}$

9)  $P_1 = (2, 4); P_2 = (-2, -3)$

A) 28

B) 3

C)  $\sqrt{33}$

D)  $\sqrt{65}$

10)  $P_1 = (4, -7); P_2 = (6, -1)$

A) 4

B)  $2\sqrt{10}$

C) 32

D)  $32\sqrt{2}$

- 11)  $P_1 = (-4, -7)$ ;  $P_2 = (2, -3)$   
 A) 20                                      B)  $20\sqrt{5}$                                       C) 2                                      D)  $2\sqrt{13}$
- 12)  $P_1 = (0.1, 0.3)$ ;  $P_2 = (1.9, -1.4)$  Round to three decimal places, if necessary.  
 A) 7.829                                      B) 2.576                                      C) 17.5                                      D) 2.476

**Decide whether or not the points are the vertices of a right triangle.**

- 13)  $(6, -6)$ ,  $(13, -6)$ ,  $(13, 0)$   
 A) Yes                                      B) No
- 14)  $(9, -3)$ ,  $(11, 1)$ ,  $(13, 0)$   
 A) Yes                                      B) No
- 15)  $(-8, -5)$ ,  $(-2, -3)$ ,  $(-3, -8)$   
 A) Yes                                      B) No
- 16)  $(-9, -4)$ ,  $(-3, -2)$ ,  $(3, -9)$   
 A) Yes                                      B) No

**Solve the problem.**

- 17) Find all values of  $k$  so that the given points are  $\sqrt{29}$  units apart.  
 $(-5, 5)$ ,  $(k, 0)$   
 A) 3, 7                                      B) 7                                      C) -7                                      D) -3, -7
- 18) Find the area of the right triangle ABC with  $A = (-2, 7)$ ,  $B = (7, -1)$ ,  $C = (3, 9)$ .  
 A) 29 square units                      B)  $\frac{\sqrt{29}}{2}$  square units                      C)  $\frac{\sqrt{58}}{2}$  square units                      D) 58 square units
- 19) Find all the points having an  $x$ -coordinate of 9 whose distance from the point  $(3, -2)$  is 10.  
 A)  $(9, -12)$ ,  $(9, 8)$                       B)  $(9, 13)$ ,  $(9, -7)$                       C)  $(9, 2)$ ,  $(9, -4)$                       D)  $(9, 6)$ ,  $(9, -10)$
- 20) A middle school's baseball playing field is a square, 75 feet on a side. How far is it directly from home plate to second base (the diagonal of the square)? If necessary, round to the nearest foot.  
 A) 113 feet                                      B) 107 feet                                      C) 105 feet                                      D) 106 feet
- 21) A motorcycle and a car leave an intersection at the same time. The motorcycle heads north at an average speed of 20 miles per hour, while the car heads east at an average speed of 48 miles per hour. Find an expression for their distance apart in miles at the end of  $t$  hours.  
 A)  $52\sqrt{t}$  miles                                      B)  $t\sqrt{68}$  miles                                      C)  $2t\sqrt{13}$  miles                                      D)  $52t$  miles
- 22) A rectangular city park has a jogging loop that goes along a length, width, and diagonal of the park. To the nearest yard, find the length of the jogging loop, if the length of the park is 125 yards and its width is 75 yards.  
 A) 345 yards                                      B) 145 yards                                      C) 146 yards                                      D) 346 yards

23) Find the length of each side of the triangle determined by the three points  $P_1$ ,  $P_2$ , and  $P_3$ . State whether the triangle is an isosceles triangle, a right triangle, neither of these, or both.

$$P_1 = (-5, -4), P_2 = (-3, 4), P_3 = (0, -1)$$

A)  $d(P_1, P_2) = 2\sqrt{17}$ ;  $d(P_2, P_3) = \sqrt{34}$ ;  $d(P_1, P_3) = 5\sqrt{2}$   
neither

B)  $d(P_1, P_2) = 2\sqrt{17}$ ;  $d(P_2, P_3) = \sqrt{34}$ ;  $d(P_1, P_3) = 5\sqrt{2}$   
right triangle

C)  $d(P_1, P_2) = 2\sqrt{17}$ ;  $d(P_2, P_3) = \sqrt{34}$ ;  $d(P_1, P_3) = \sqrt{34}$   
isosceles triangle

D)  $d(P_1, P_2) = 2\sqrt{17}$ ;  $d(P_2, P_3) = \sqrt{34}$ ;  $d(P_1, P_3) = \sqrt{34}$   
both

### 3 Use the Midpoint Formula

MULTIPLE CHOICE. Choose the one alternative that best completes the statement or answers the question.

Find the midpoint of the line segment joining the points  $P_1$  and  $P_2$ .

1)  $P_1 = (8, 2)$ ;  $P_2 = (4, 4)$

A) (3, 6)

B) (6, 3)

C) (12, 6)

D) (4, -2)

2)  $P_1 = (-8, 7)$ ;  $P_2 = (5, -8)$

A)  $(-3, -1)$

B)  $(-13, 15)$

C)  $\left(-\frac{13}{2}, \frac{15}{2}\right)$

D)  $\left(-\frac{3}{2}, -\frac{1}{2}\right)$

3)  $P_1 = (7, 1)$ ;  $P_2 = (-16, -16)$

A)  $\left(\frac{23}{2}, \frac{17}{2}\right)$

B)  $\left(-\frac{9}{2}, -\frac{15}{2}\right)$

C)  $(-9, -15)$

D)  $(9, 15)$

4)  $P_1 = (0.3, -0.1)$ ;  $P_2 = (-2.4, -1.4)$

A)  $(-0.65, -1.35)$

B)  $(-1.35, -0.65)$

C)  $(-0.75, -1.05)$

D)  $(-1.05, -0.75)$

5)  $P_1 = (b, 7)$ ;  $P_2 = (0, 8)$

A)  $(b, 15)$

B)  $\left(\frac{b}{2}, \frac{15}{2}\right)$

C)  $\left(-\frac{b}{2}, 1\right)$

D)  $\left(b, \frac{15}{2}\right)$

6)  $P_1 = (2x, 4)$ ;  $P_2 = (3x, 9)$

A)  $\left(\frac{5x}{2}, \frac{13}{2}\right)$

B)  $(5x, 13)$

C)  $\left(\frac{13x}{2}, \frac{5}{2}\right)$

D)  $(x, 5)$

Solve the problem.

7) If  $(3, 2)$  is the endpoint of a line segment, and  $(7, 4)$  is its midpoint, find the other endpoint.

A)  $(-5, -2)$

B)  $(11, 0)$

C)  $(11, 6)$

D)  $(7, 10)$

8) If  $(5, 5)$  is the endpoint of a line segment, and  $(4, 1)$  is its midpoint, find the other endpoint.

A)  $(3, -3)$

B)  $(7, 13)$

C)  $(3, 9)$

D)  $(-3, 3)$

9) If  $(-7, -2)$  is the endpoint of a line segment, and  $(-6, -4)$  is its midpoint, find the other endpoint.

A)  $(-11, 0)$

B)  $(-5, 0)$

C)  $(-5, -6)$

D)  $(-9, 2)$

10) If  $(-8, -9)$  is the endpoint of a line segment, and  $(-12, -6)$  is its midpoint, find the other endpoint.

A)  $(-16, -12)$

B)  $(-2, -17)$

C)  $(0, -15)$

D)  $(-16, -3)$

11) The medians of a triangle intersect at a point. The distance from the vertex to the point is exactly two-thirds of the distance from the vertex to the midpoint of the opposite side. Find the exact distance of that point from the vertex A(3, 4) of a triangle, given that the other two vertices are at (0, 0) and (8, 0).

A)  $\frac{\sqrt{17}}{3}$

B)  $\frac{2\sqrt{17}}{3}$

C) 2

D)  $\frac{8}{3}$

## 2.2 Graphs of Equations in Two Variables; Intercepts; Symmetry

### 1 Graph Equations by Plotting Points

MULTIPLE CHOICE. Choose the one alternative that best completes the statement or answers the question.

**Determine whether the given point is on the graph of the equation.**

1) Equation:  $y = x^3 - \sqrt{x}$

Point: (0, 0)

A) No

B) Yes

2) Equation:  $x^2 - y^2 = 16$

Point: (4, 0)

A) Yes

B) No

Graph the equation by plotting points.

3)  $y = x - 3$

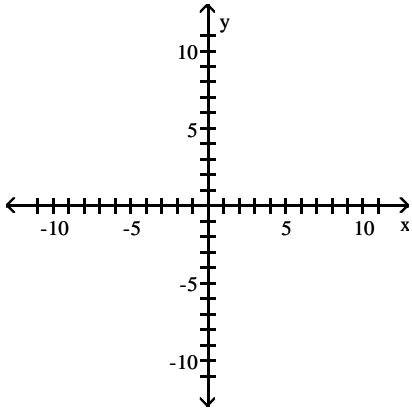

A)

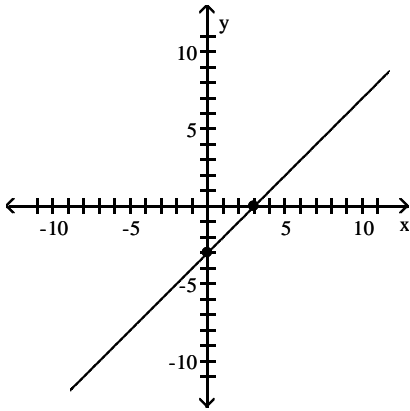

B)

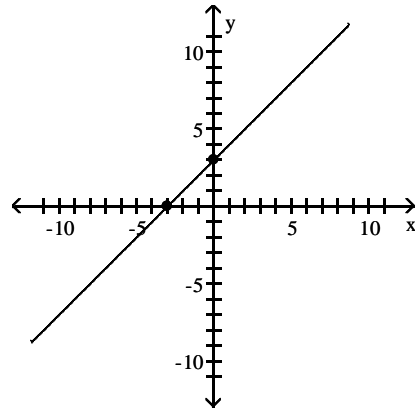

C)

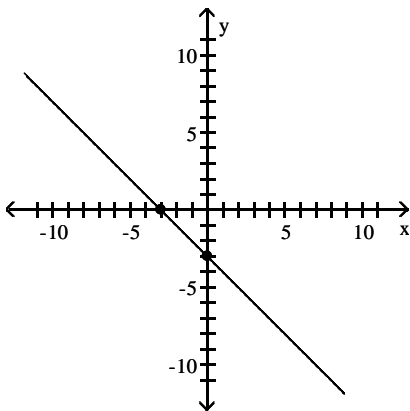

D)

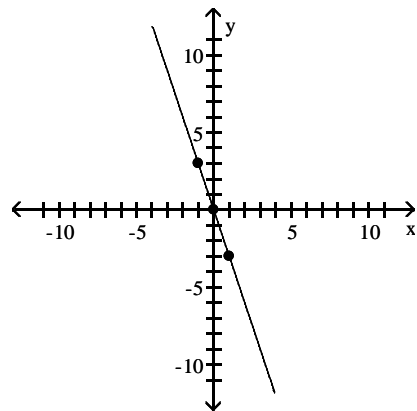

4)  $y = 3x + 6$

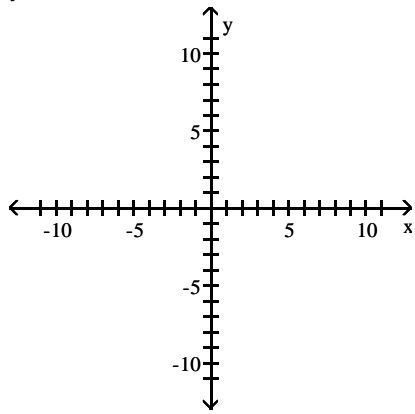

A)

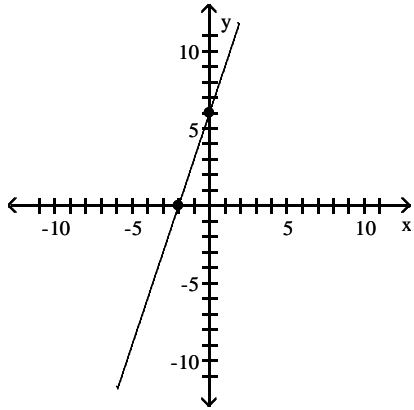

B)

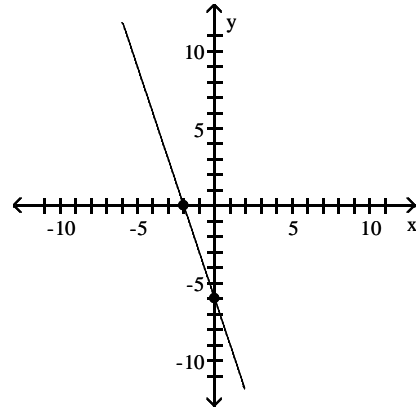

C)

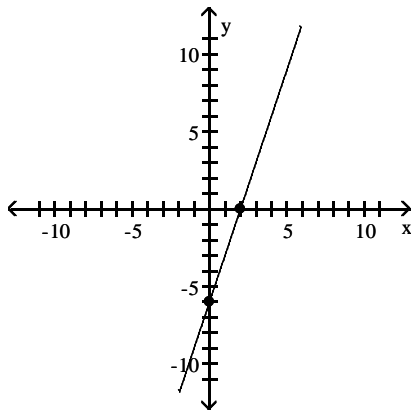

D)

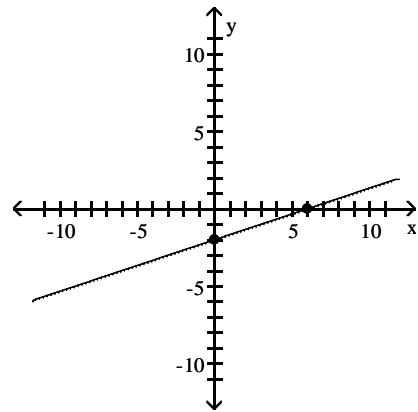



5)  $y = -x^2 + 9$

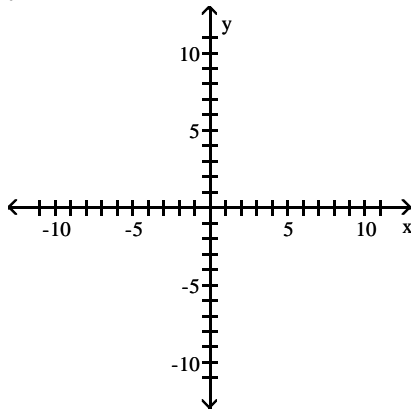

A)

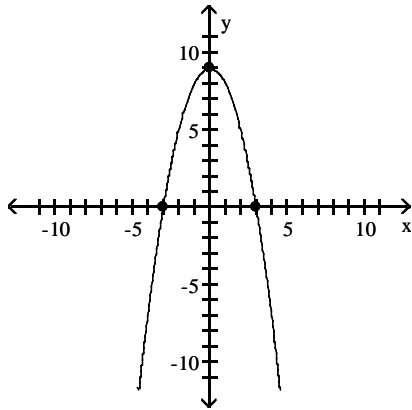

B)

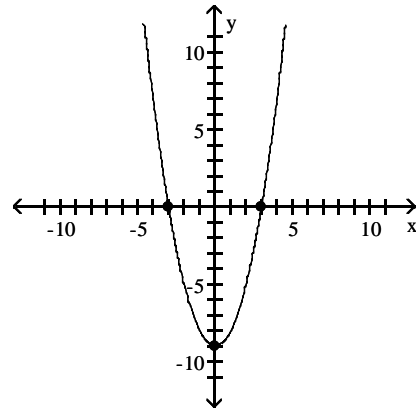

C)

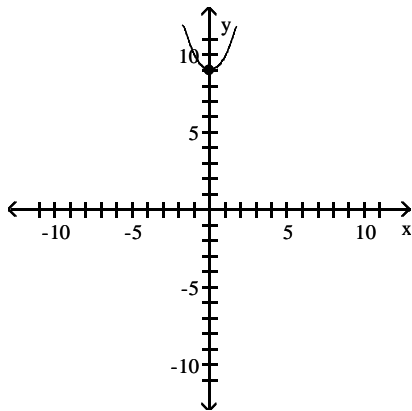

D)

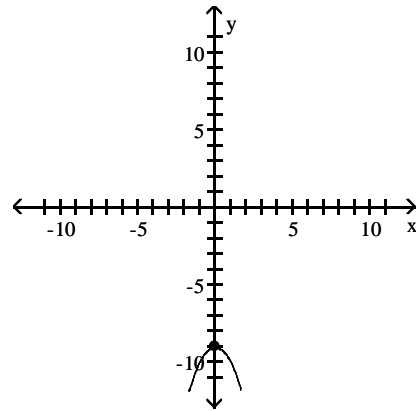

6)  $4x + 5y = 20$

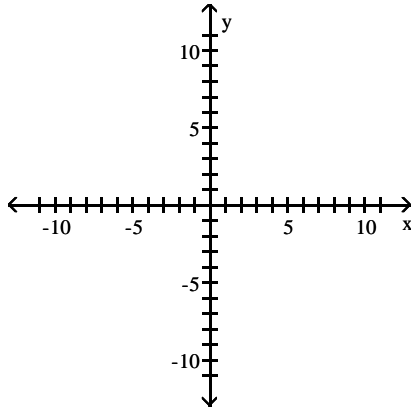

A)

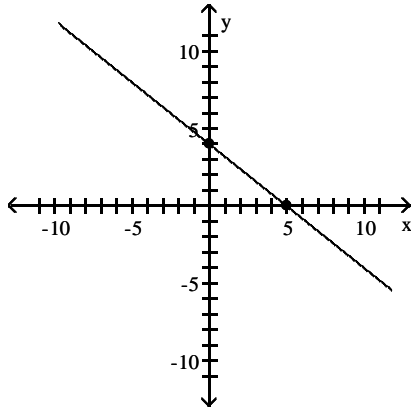

B)

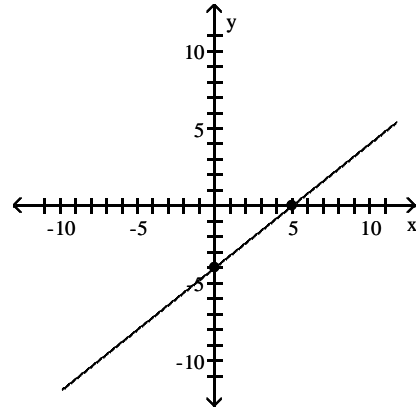

C)

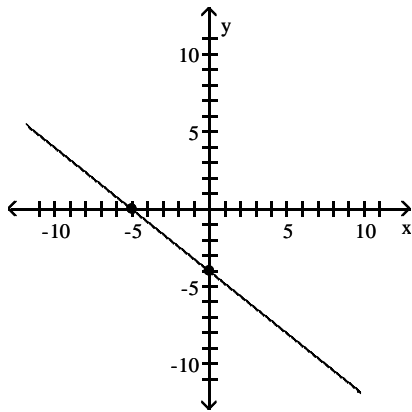

D)

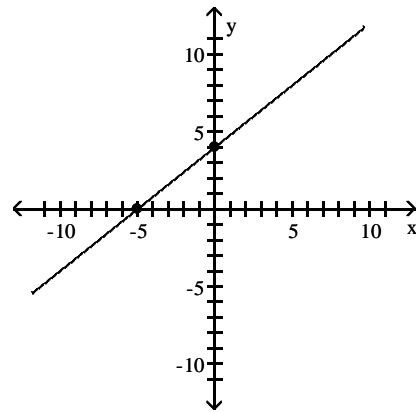

7)  $x^2 + 4y = 4$

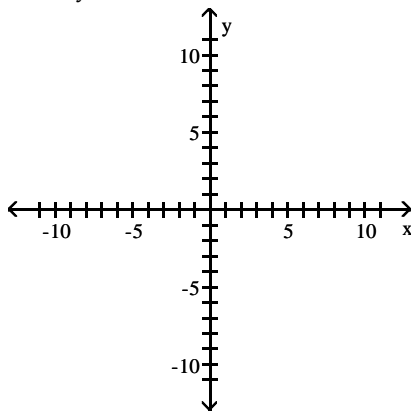

A)

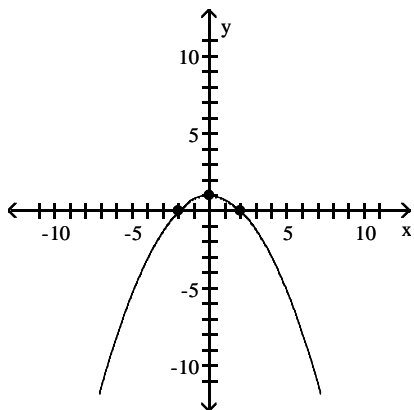

C)

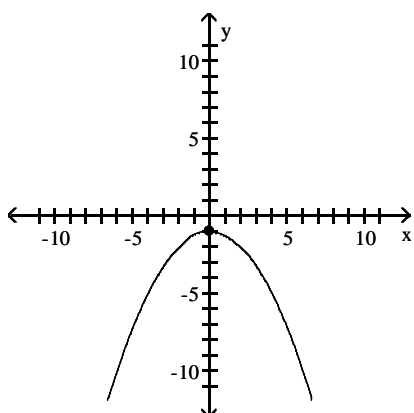

B)

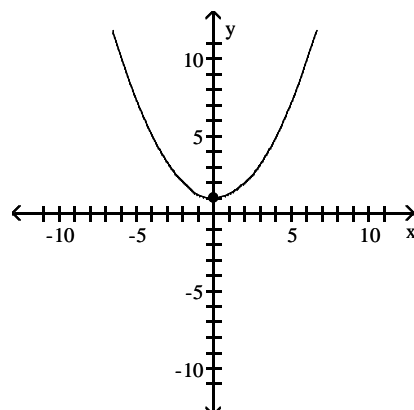

D)

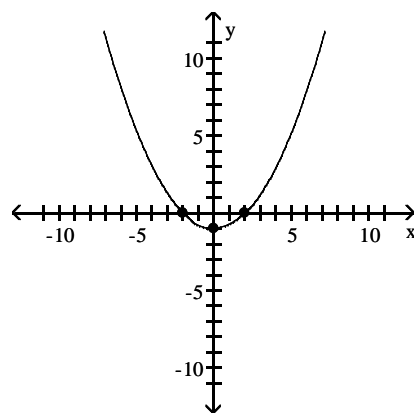

**Solve the problem.**

8) If  $(a, 3)$  is a point on the graph of  $y = 2x - 5$ , what is  $a$ ?

A) 1

B) -1

C) -4

D) 4

9) If  $(3, b)$  is a point on the graph of  $3x - 2y = 17$ , what is  $b$ ?

A) 4

B) -4

C)  $\frac{23}{3}$

D)  $\frac{11}{3}$

10) The height of a baseball (in feet) at time  $t$  (in seconds) is given by  $y = -16x^2 + 80x + 5$ . Which one of the following points is not on the graph of the equation?

A)  $(3, 101)$

B)  $(4, 69)$

C)  $(1, 69)$

D)  $(2, 117)$

## 2 Find Intercepts from a Graph

MULTIPLE CHOICE. Choose the one alternative that best completes the statement or answers the question.

List the intercepts of the graph.

1)

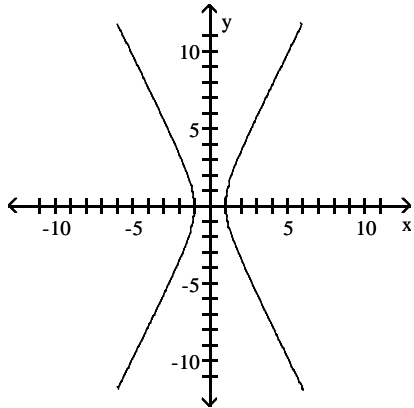

A)  $(0, -1), (0, 1)$

B)  $(-1, 0), (0, 1)$

C)  $(0, -1), (1, 0)$

D)  $(-1, 0), (1, 0)$

2)

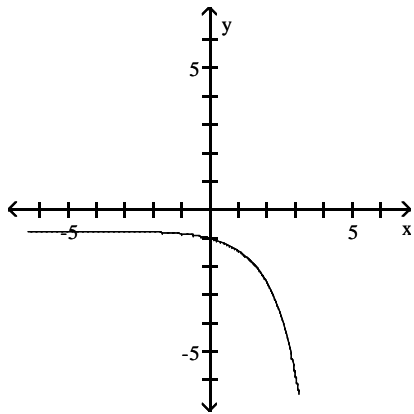

A)  $(-1, 0)$

B)  $(-1, -1)$

C)  $(0, 0)$

D)  $(0, -1)$

3)

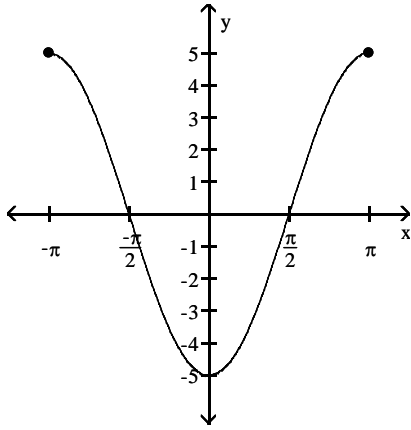

A)  $\left(0, -\frac{\pi}{2}\right), (0, -5), \left(0, \frac{\pi}{2}\right)$   
 C)  $\left(-\frac{\pi}{2}, 0\right), (-5, 0), \left(\frac{\pi}{2}, 0\right)$

B)  $\left(0, -\frac{\pi}{2}\right), (-5, 0), \left(0, \frac{\pi}{2}\right)$   
 D)  $\left(-\frac{\pi}{2}, 0\right), (0, -5), \left(\frac{\pi}{2}, 0\right)$

4)

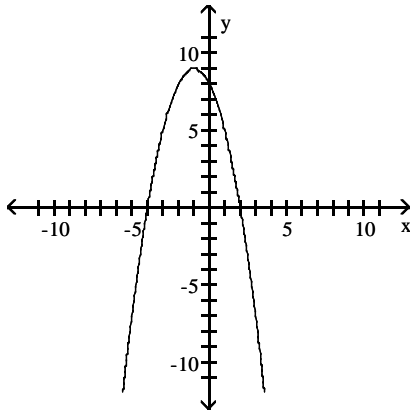

A)  $(-4, 0), (0, 8), (0, 2)$

B)  $(0, -4), (0, 8), (2, 0)$

C)  $(0, -4), (8, 0), (0, 2)$

D)  $(-4, 0), (0, 8), (2, 0)$

5)

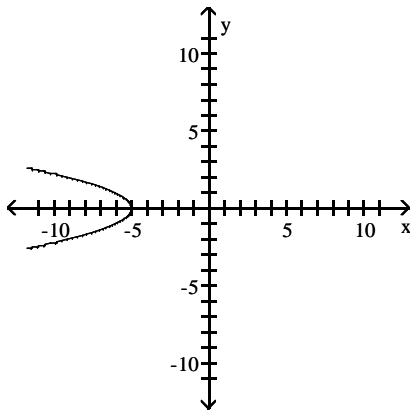

A)  $(0, 5)$

B)  $(0, -5)$

C)  $(-5, 0)$

D)  $(5, 0)$

6)

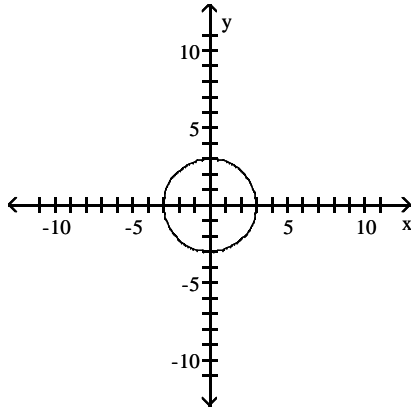

- A)  $(-3, 0), (0, -3), (0, 3), (3, 0)$   
 C)  $(0, 3), (3, 0)$

- B)  $(-3, 0), (0, 3)$   
 D)  $(-3, 0), (0, -3), (0, 0), (0, 3), (3, 0)$

7)

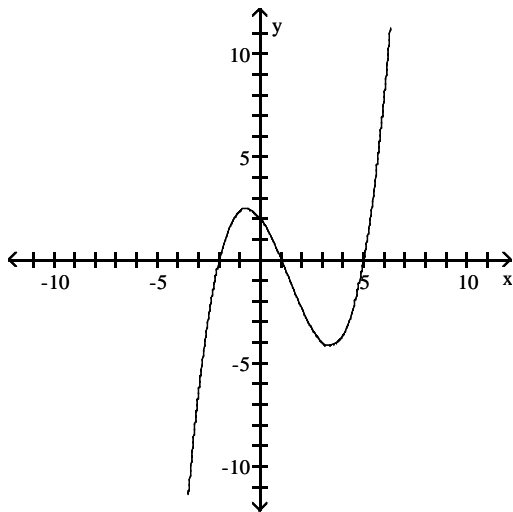

- A)  $(2, 0), (1, 0), (-5, 0), (0, 2)$   
 C)  $(-2, 0), (1, 0), (5, 0), (0, 2)$

- B)  $(2, 0), (0, -2), (0, 1), (0, 5)$   
 D)  $(2, 0), (0, 2), (0, 1), (0, -5)$

8)

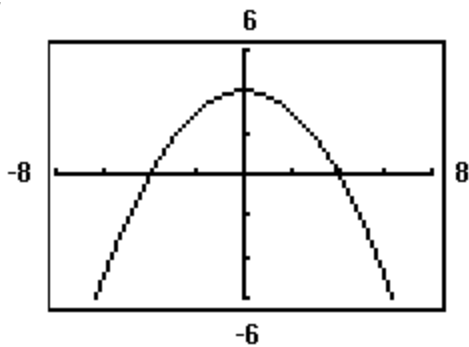

- A)  $(-2, 0), (0, 2), (2, 0)$       B)  $(-2, 0), (2, 0)$       C)  $(-4, 0), (0, 4), (4, 0)$       D)  $(-2, 0), (0, 4), (2, 0)$

### 3 Find Intercepts from an Equation

MULTIPLE CHOICE. Choose the one alternative that best completes the statement or answers the question.

List the intercepts for the graph of the equation.

1)  $y = x + 5$

A) (5, 0), (0, 5)

B) (-5, 0), (0, 5)

C) (5, 0), (0, -5)

D) (-5, 0), (0, -5)

2)  $y = 3x$

A) (0, 3)

B) (3, 3)

C) (0, 0)

D) (3, 0)

3)  $y^2 = x + 1$

A) (0, -1), (-1, 0), (0, 1)

B) (0, -1), (1, 0), (0, 1)

C) (1, 0), (0, 1), (0, -1)

D) (-1, 0), (0, -1), (1, 0)

4)  $y = \sqrt[5]{x}$

A) (0, 0)

B) (1, 1)

C) (0, 1)

D) (1, 0)

5)  $x^2 + y - 16 = 0$

A) (-4, 0), (0, -16), (4, 0)

B) (4, 0), (0, 16), (0, -16)

C) (0, -4), (16, 0), (0, 4)

D) (-4, 0), (0, 16), (4, 0)

6)  $9x^2 + 16y^2 = 144$

A) (-9, 0), (-16, 0), (16, 0), (9, 0)

B) (-4, 0), (0, -3), (0, 3), (4, 0)

C) (-16, 0), (0, -9), (0, 9), (16, 0)

D) (-3, 0), (-4, 0), (4, 0), (3, 0)

7)  $4x^2 + y^2 = 4$

A) (-1, 0), (0, -4), (0, 4), (1, 0)

B) (-4, 0), (0, -1), (0, 1), (4, 0)

C) (-1, 0), (0, -2), (0, 2), (1, 0)

D) (-2, 0), (0, -1), (0, 1), (2, 0)

8)  $y = x^3 - 27$

A) (-27, 0), (0, 3)

B) (0, -3), (0, 3)

C) (0, -3), (-3, 0)

D) (0, -27), (3, 0)

9)  $y = x^4 - 16$

A) (0, -16), (-2, 0), (2, 0)

B) (0, 16), (-2, 0), (2, 0)

C) (0, 16)

D) (0, -16)

10)  $y = x^2 + 14x + 48$

A) (0, 6), (0, 8), (48, 0)

B) (-6, 0), (-8, 0), (0, 48)

C) (6, 0), (8, 0), (0, 48)

D) (0, -6), (0, -8), (48, 0)

11)  $y = x^2 + 16$

A) (16, 0), (0, -4), (0, 4)

B) (16, 0)

C) (0, 16), (-4, 0), (4, 0)

D) (0, 16)

12)  $y = \frac{3x}{x^2 + 9}$

A) (-9, 0), (0, 0), (9, 0)

B) (-3, 0), (0, 0), (3, 0)

C) (0, 0)

D) (0, -3), (0, 0), (0, 3)

$$13) y = \frac{x^2 - 16}{4x^4}$$

A) (0, -4), (0, 4)

C) (-16, 0), (0, 0), (16, 0)

B) (-4, 0), (4, 0)

D) (0, 0)



#### 4 Test an Equation for Symmetry with Respect to the $x$ -Axis, the $y$ -Axis, and the Origin

MULTIPLE CHOICE. Choose the one alternative that best completes the statement or answers the question.

Plot the point A. Plot the point B that has the given symmetry with point A.

- 1)  $A = (-3, -4)$ ; B is symmetric to A with respect to the  $y$ -axis

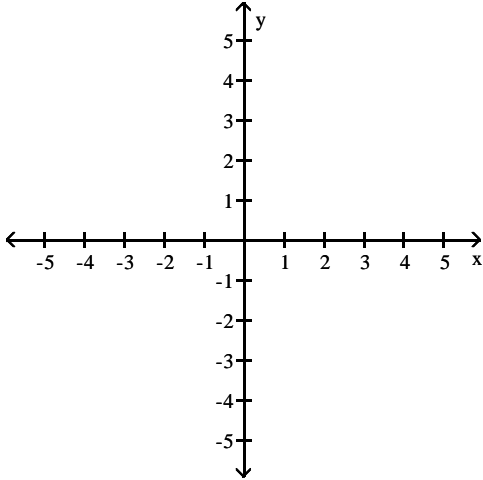

A)

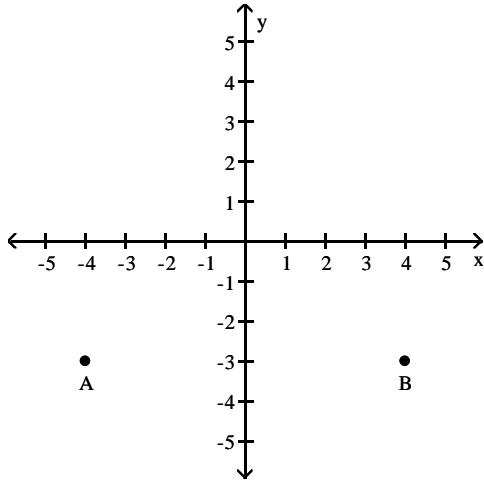

B)

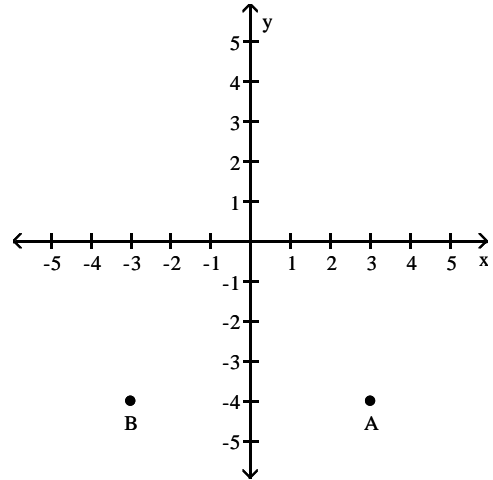

C)

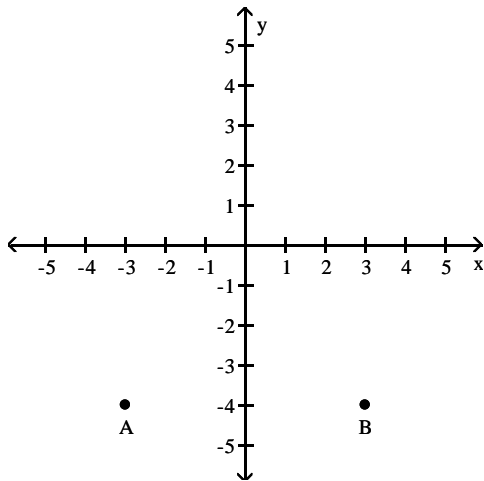

D)

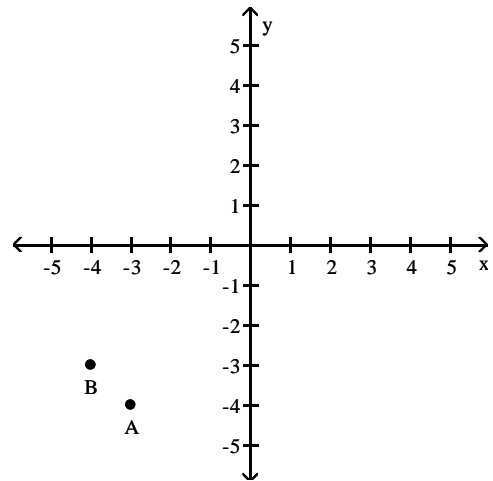

2)  $A = (0, 4)$ ; B is symmetric to A with respect to the origin

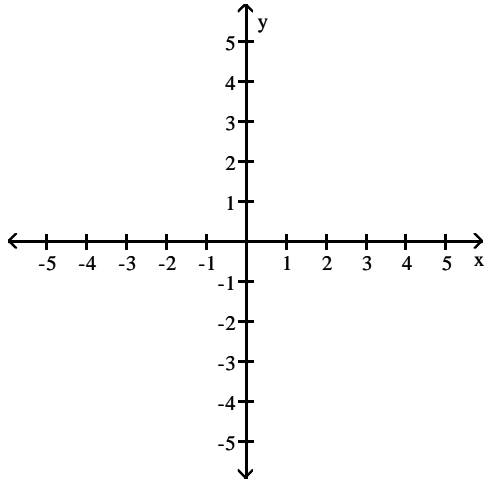

A)

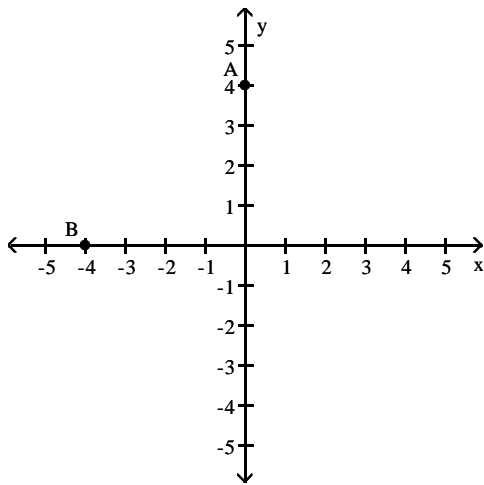

B)

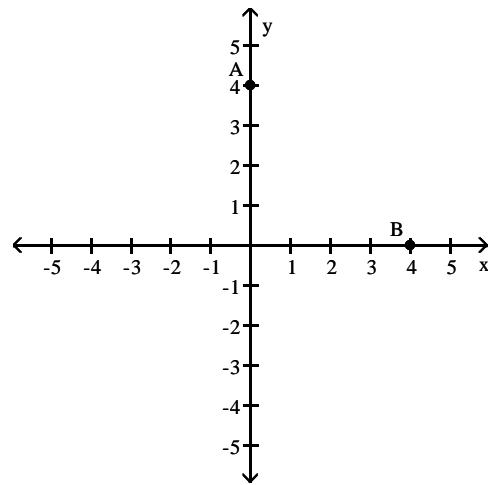

C)

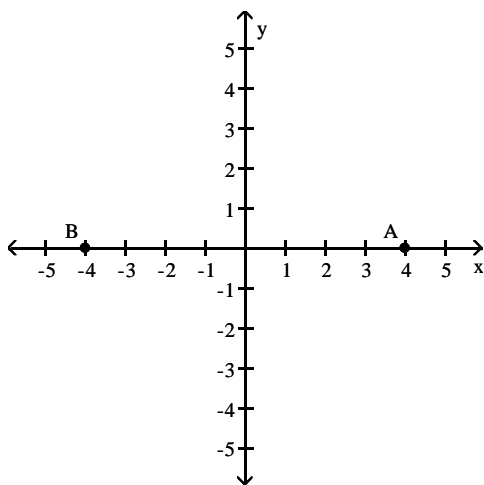

D)

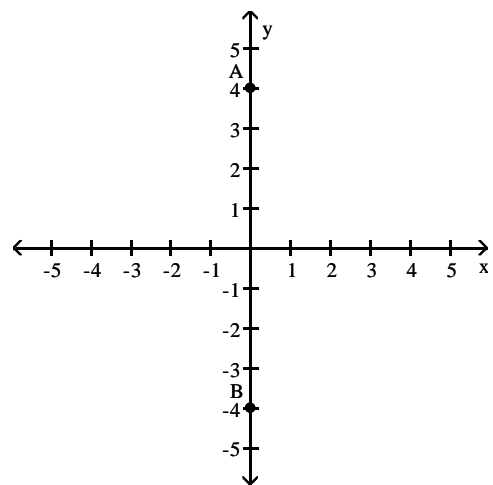

List the intercepts of the graph. Tell whether the graph is symmetric with respect to the  $x$ -axis,  $y$ -axis, origin, or none of these.

3)

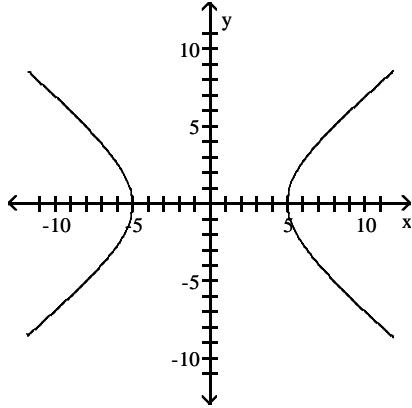

- A) intercepts:  $(0, -5)$  and  $(0, 5)$   
symmetric with respect to  $y$ -axis
- B) intercepts:  $(-5, 0)$  and  $(5, 0)$   
symmetric with respect to origin
- C) intercepts:  $(-5, 0)$  and  $(5, 0)$   
symmetric with respect to  $x$ -axis,  $y$ -axis, and origin
- D) intercepts:  $(0, -5)$  and  $(0, 5)$   
symmetric with respect to  $x$ -axis,  $y$ -axis, and origin

4)

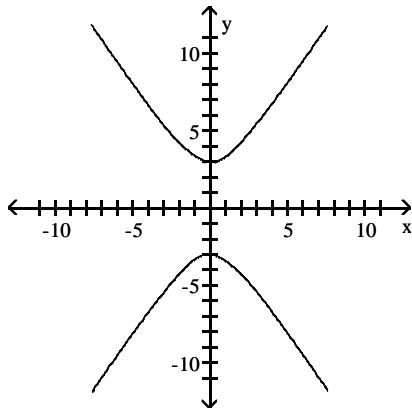

- A) intercepts:  $(3, 0)$  and  $(-3, 0)$   
symmetric with respect to  $y$ -axis
- B) intercepts:  $(0, 3)$  and  $(0, -3)$   
symmetric with respect to origin
- C) intercepts:  $(0, 3)$  and  $(0, -3)$   
symmetric with respect to  $x$ -axis,  $y$ -axis, and origin
- D) intercepts:  $(3, 0)$  and  $(-3, 0)$   
symmetric with respect to  $x$ -axis,  $y$ -axis, and origin

5)

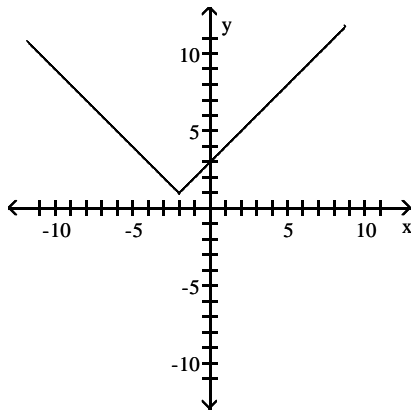

- A) intercept: (3, 0)  
symmetric with respect to y-axis
- C) intercept: (3, 0)  
no symmetry

- B) intercept: (0, 3)  
no symmetry
- D) intercept: (0, 3)  
symmetric with respect to x-axis

6)

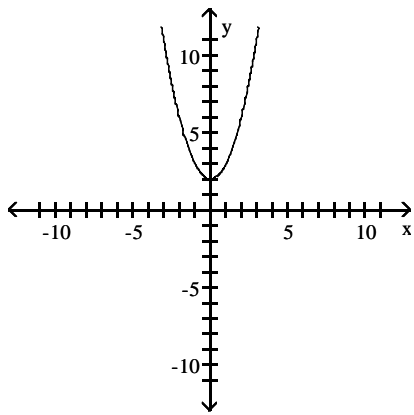

- A) intercept: (0, 2)  
symmetric with respect to origin
- C) intercept: (2, 0)  
symmetric with respect to x-axis

- B) intercept: (2, 0)  
symmetric with respect to y-axis
- D) intercept: (0, 2)  
symmetric with respect to y-axis

7)

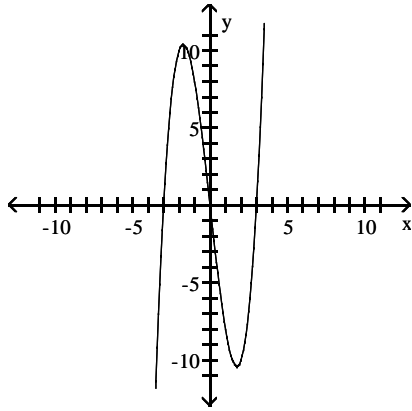

- A) intercepts:  $(-3, 0), (0, 0), (3, 0)$   
symmetric with respect to  $y$ -axis
- B) intercepts:  $(-3, 0), (0, 0), (3, 0)$   
symmetric with respect to origin
- C) intercepts:  $(-3, 0), (0, 0), (3, 0)$   
symmetric with respect to  $x$ -axis,  $y$ -axis, and origin
- D) intercepts:  $(-3, 0), (0, 0), (3, 0)$   
symmetric with respect to  $x$ -axis

Draw a complete graph so that it has the given type of symmetry.

8) Symmetric with respect to the  $y$ -axis

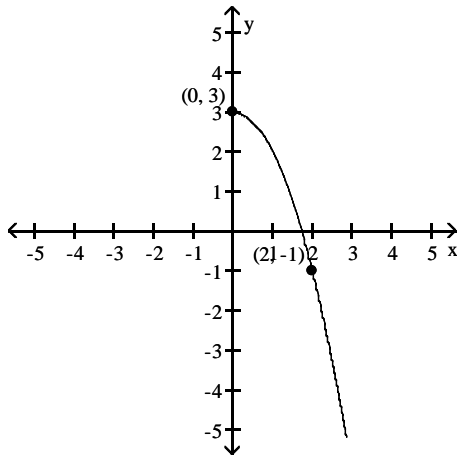

A)

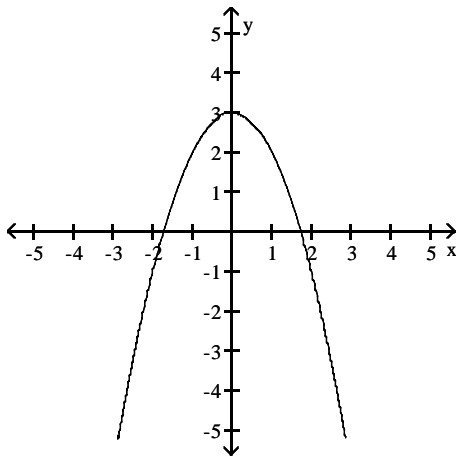

B)

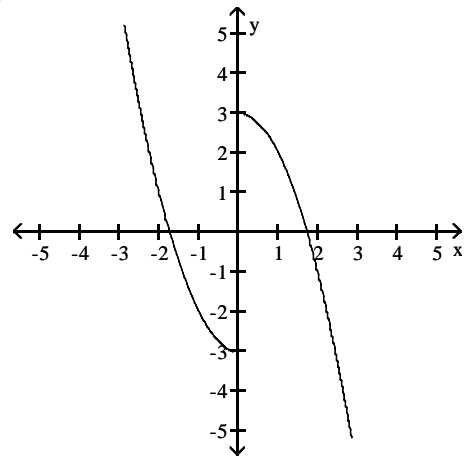

C)

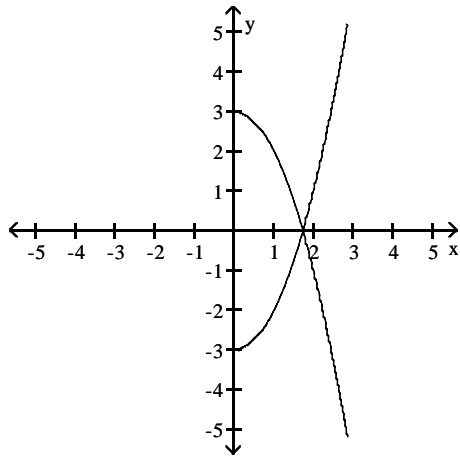

D)

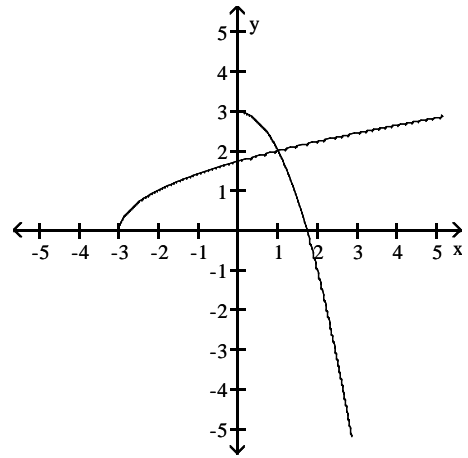

9) origin

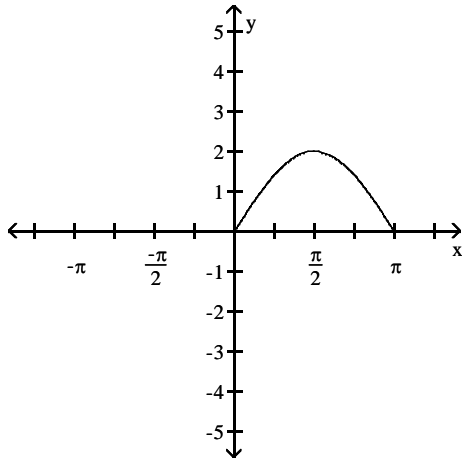

A)

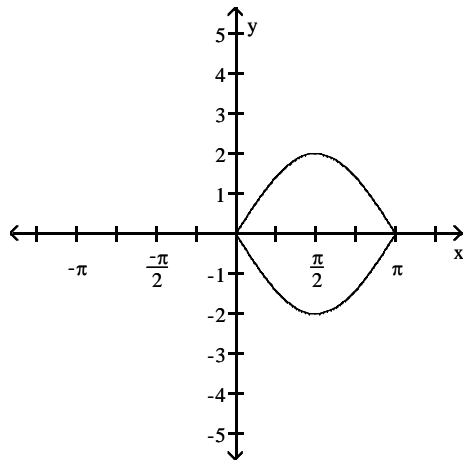

B)

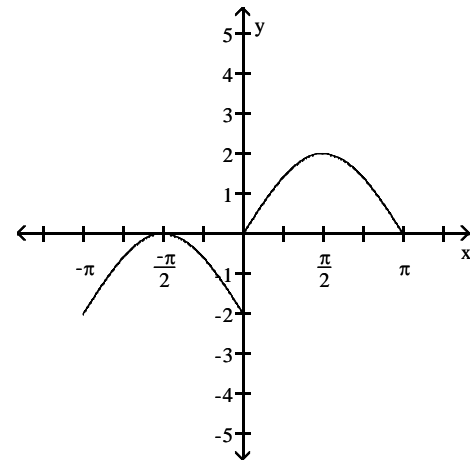

C)

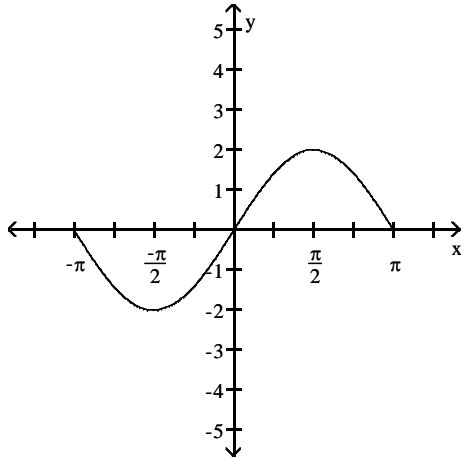

D)

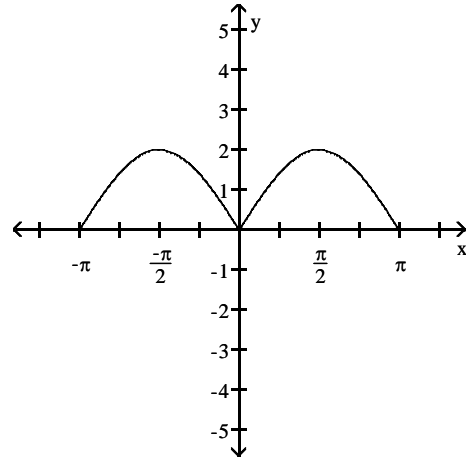

10) Symmetric with respect to the x-axis

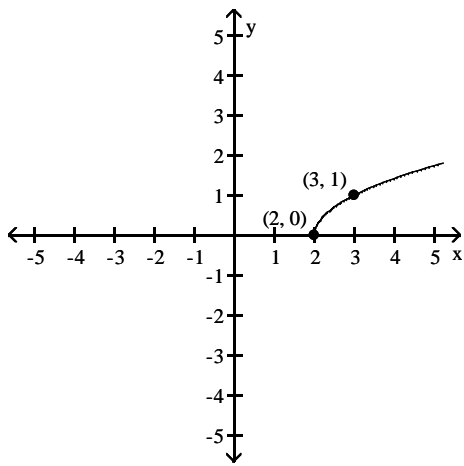

A)

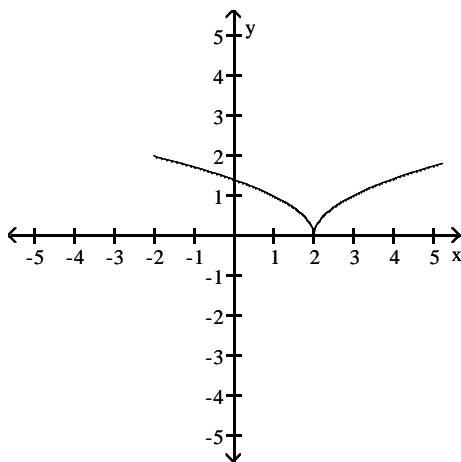

B)

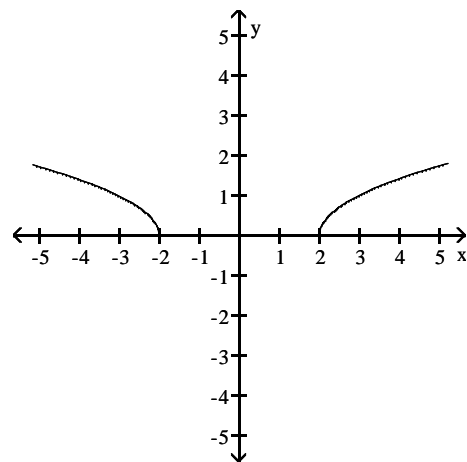

C)

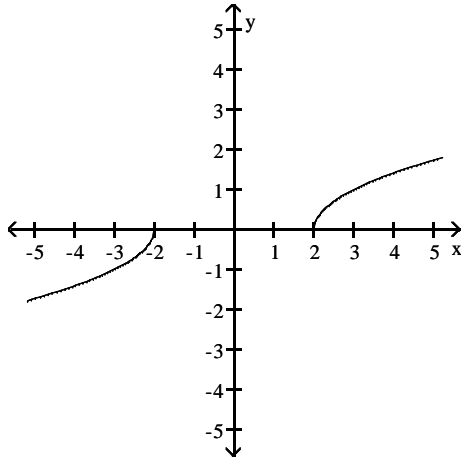

D)

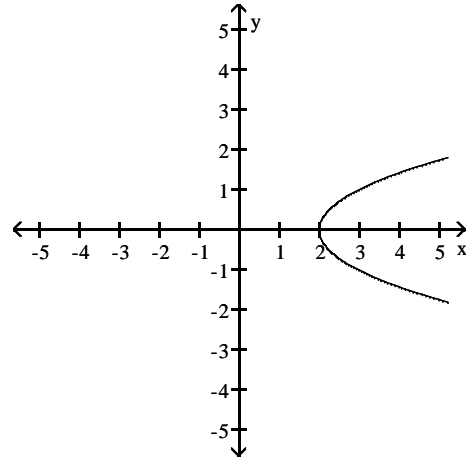

List the intercepts and type(s) of symmetry, if any.

11)  $y^2 = x + 4$

- A) intercepts: (0, 4), (2, 0), (-2, 0)  
symmetric with respect to y-axis  
C) intercepts: (4, 0), (0, 2), (0, -2)  
symmetric with respect to x-axis

- B) intercepts: (-4, 0), (0, 2), (0, -2)  
symmetric with respect to x-axis  
D) intercepts: (0, -4), (2, 0), (-2, 0)  
symmetric with respect to y-axis

12)  $16x^2 + 9y^2 = 144$

- A) intercepts: (3, 0), (-3, 0), (0, 4), (0, -4)  
symmetric with respect to x-axis, y-axis, and origin  
B) intercepts: (3, 0), (-3, 0), (0, 4), (0, -4)  
symmetric with respect to x-axis and y-axis  
C) intercepts: (4, 0), (-4, 0), (0, 3), (0, -3)  
symmetric with respect to the origin  
D) intercepts: (4, 0), (-4, 0), (0, 3), (0, -3)  
symmetric with respect to x-axis and y-axis

13)  $y = \frac{-x}{x^2 - 7}$

- A) intercept: (0, 0)  
symmetric with respect to x-axis  
C) intercepts:  $(\sqrt{7}, 0)$ ,  $(-\sqrt{7}, 0)$ , (0, 0)  
symmetric with respect to origin

- B) intercept: (0, 0)  
symmetric with respect to y-axis  
D) intercept: (0, 0)  
symmetric with respect to origin

Determine whether the graph of the equation is symmetric with respect to the x-axis, the y-axis, and/or the origin.

14)  $y = x + 2$

- A) x-axis  
B) origin  
C) y-axis  
D) x-axis, y-axis, origin  
E) none



- 15)  $y = -4x$   
A) y-axis  
B) x-axis  
C) origin  
D) x-axis, y-axis, origin  
E) none
- 16)  $x^2 + y - 16 = 0$   
A) x-axis  
B) origin  
C) y-axis  
D) x-axis, y-axis, origin  
E) none
- 17)  $y^2 - x - 36 = 0$   
A) x-axis  
B) origin  
C) y-axis  
D) x-axis, y-axis, origin  
E) none
- 18)  $4x^2 + 9y^2 = 36$   
A) x-axis  
B) origin  
C) y-axis  
D) x-axis, y-axis, origin  
E) none
- 19)  $16x^2 + y^2 = 16$   
A) x-axis  
B) y-axis  
C) origin  
D) x-axis, y-axis, origin  
E) none
- 20)  $y = x^2 + 10x + 16$   
A) y-axis  
B) x-axis  
C) origin  
D) x-axis, y-axis, origin  
E) none
- 21)  $y = \frac{4x}{x^2 + 16}$   
A) origin  
B) y-axis  
C) x-axis  
D) x-axis, y-axis, origin  
E) none

22)  $y = \frac{x^2 - 81}{9x^4}$

- A) y-axis
- B) origin
- C) x-axis
- D) x-axis, y-axis, origin
- E) none

23)  $y = 2x^2 + 1$

- A) y-axis
- B) origin
- C) x-axis
- D) x-axis, y-axis, origin
- E) none

24)  $y = (x - 4)(x + 8)$

- A) origin
- B) x-axis
- C) y-axis
- D) x-axis, y-axis, origin
- E) none

25)  $y = -8x^3 + 4x$

- A) origin
- B) y-axis
- C) x-axis
- D) x-axis, y-axis, origin
- E) none

26)  $y = -9x^4 - 4x - 9$

- A) x-axis
- B) origin
- C) y-axis
- D) x-axis, y-axis, origin
- E) none

**Solve the problem.**

27) If a graph is symmetric with respect to the y-axis and it contains the point (5, -6), which of the following points is also on the graph?

- A) (-5, 6)                      B) (-6, 5)                      C) (5, -6)                      D) (-5, -6)

28) If a graph is symmetric with respect to the origin and it contains the point (-4, 7), which of the following points is also on the graph?

- A) (4, 7)                      B) (4, -7)                      C) (7, -4)                      D) (-4, -7)

## 5 Know How to Graph Key Equations

MULTIPLE CHOICE. Choose the one alternative that best completes the statement or answers the question.

Graph the equation by plotting points.

1)  $y = x^3$

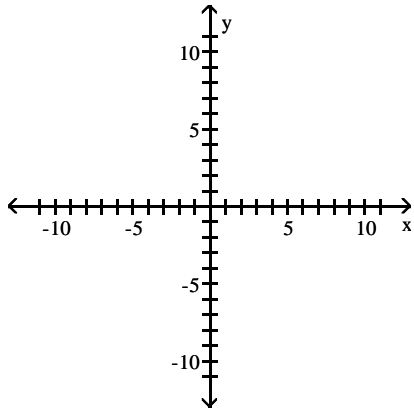

A)

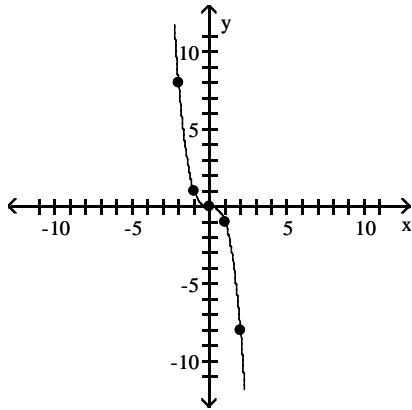

B)

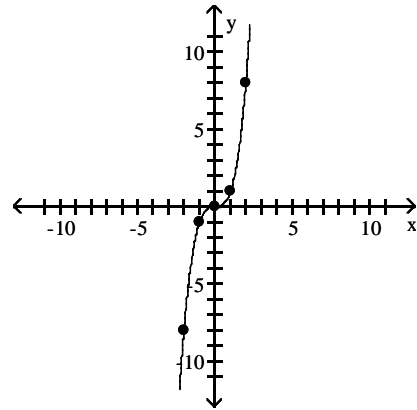

C)

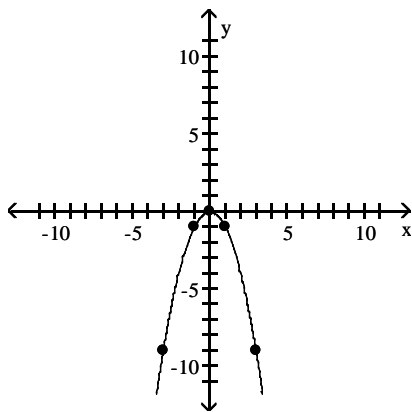

D)

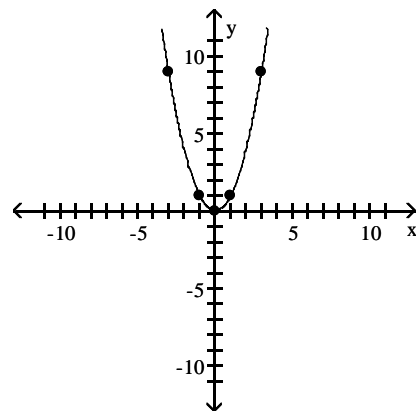

2)  $x = y^2$

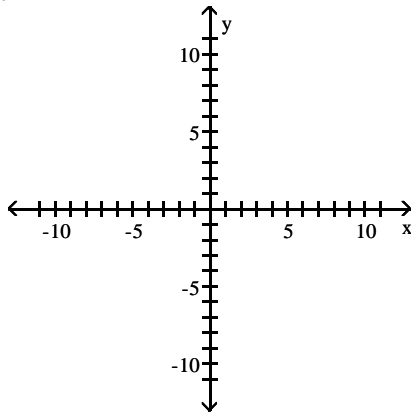

A)

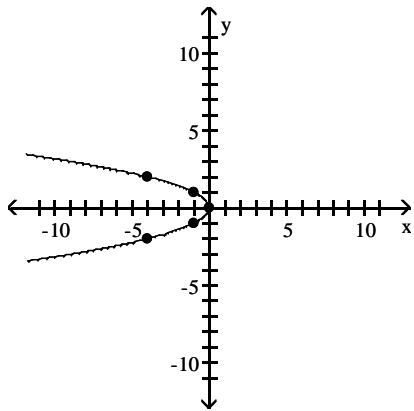

B)

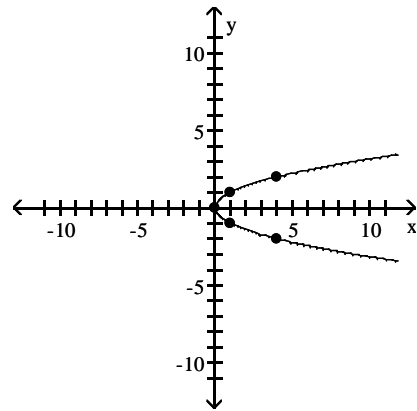

C)

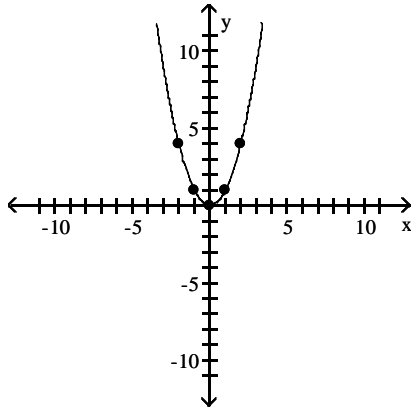

D)

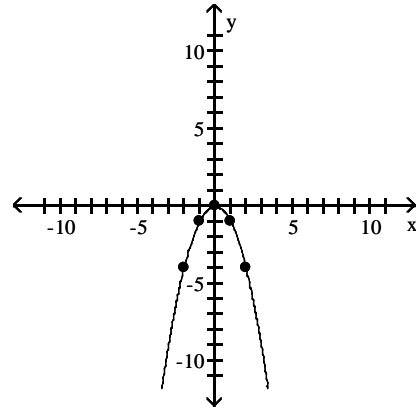

3)  $y = \sqrt{x}$

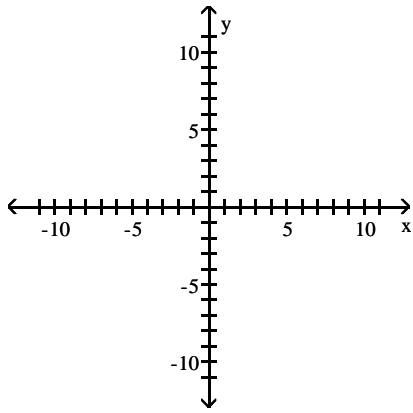

A)

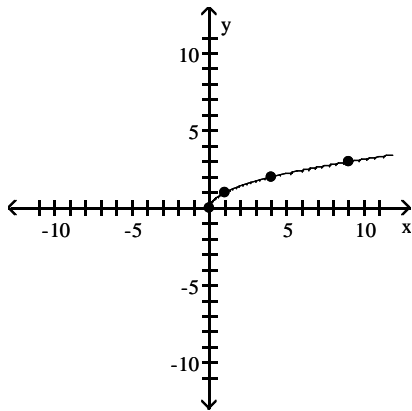

B)

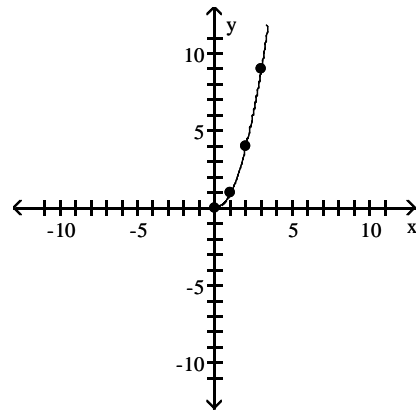

C)

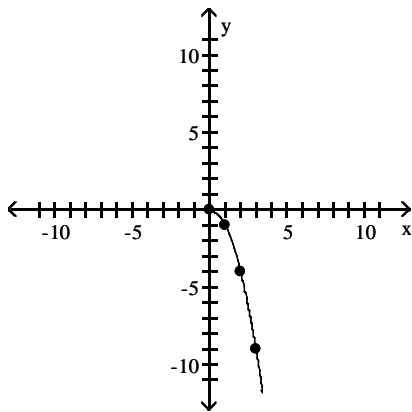

D)

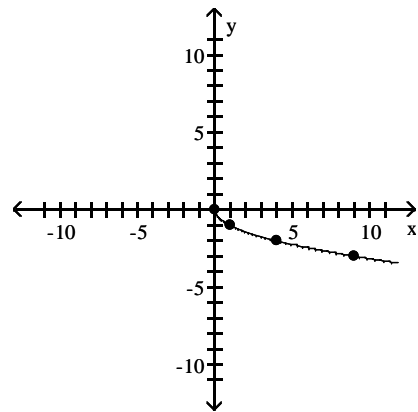

4)  $y = \frac{1}{x}$

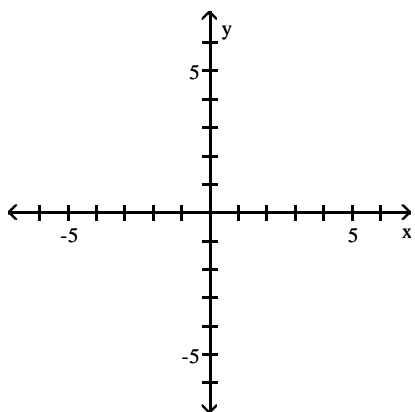

A)

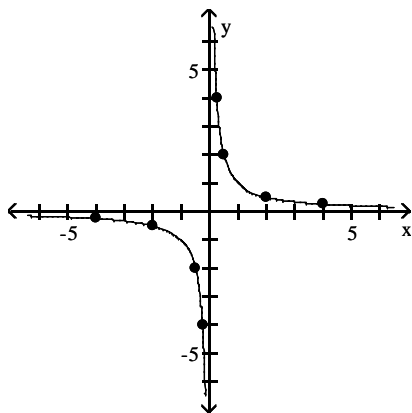

B)

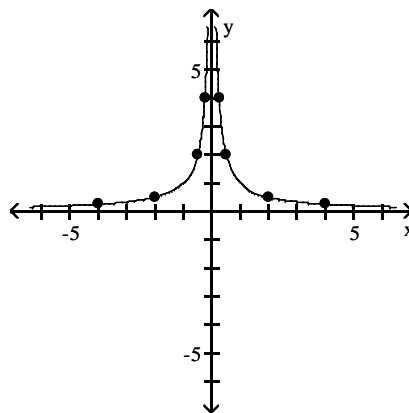

C)

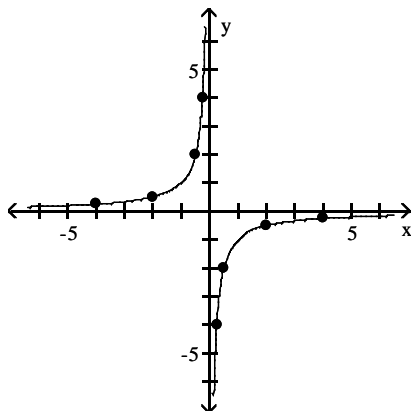

D)

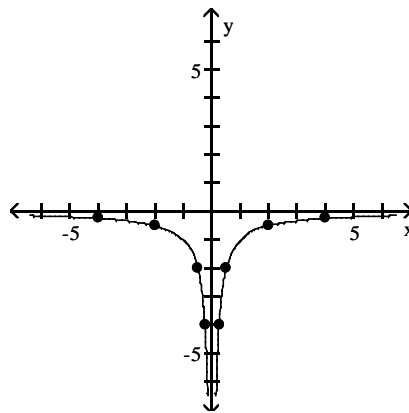

## 2.3 Lines

### 1 Calculate and Interpret the Slope of a Line

MULTIPLE CHOICE. Choose the one alternative that best completes the statement or answers the question.

Find the slope of the line through the points and interpret the slope.

1)

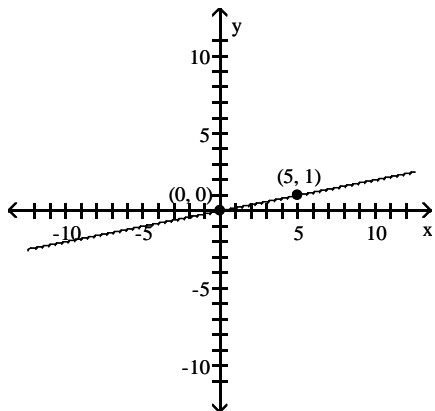

- A)  $\frac{1}{5}$ ; for every 5-unit increase in  $x$ ,  $y$  will increase by 1 unit
- B)  $-\frac{1}{5}$ ; for every 5-unit increase in  $x$ ,  $y$  will decrease by 1 unit
- C) 5; for every 1-unit increase in  $x$ ,  $y$  will increase by 5 units
- D) -5; for every 1-unit increase in  $x$ ,  $y$  will decrease by 5 units

Find the slope of the line.

2)

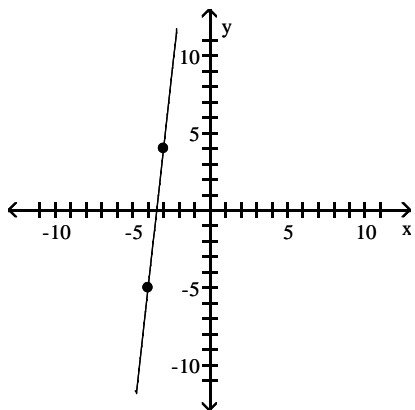

- A) -9
- B)  $-\frac{1}{9}$
- C) 9
- D)  $\frac{1}{9}$

3)

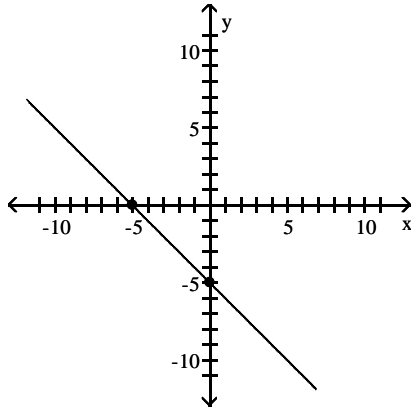

A) -5

B) 1

C) 5

D) -1

4)

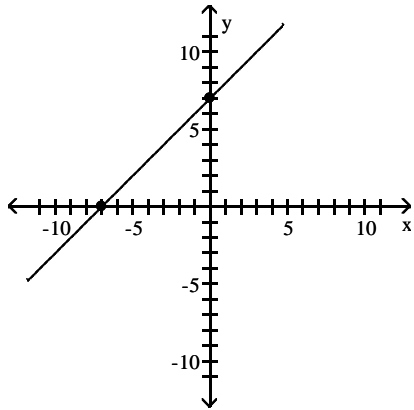

A) -1

B) -7

C) 7

D) 1

5)

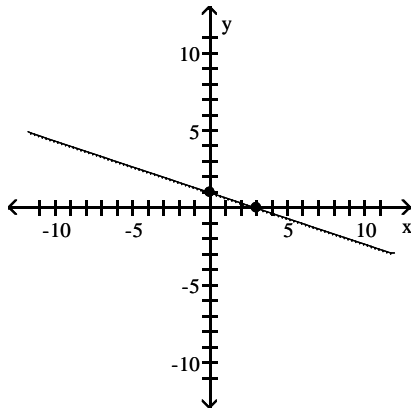

A)  $\frac{1}{3}$

B) -3

C) 3

D)  $-\frac{1}{3}$

**Find the slope of the line containing the two points.**

6) (5, 0); (-6, 5)

A)  $-\frac{5}{11}$

B)  $-\frac{11}{5}$

C)  $\frac{11}{5}$

D)  $\frac{5}{11}$



7)  $(7, 0); (0, 2)$

A)  $-\frac{2}{7}$

B)  $-\frac{7}{2}$

C)  $\frac{2}{7}$

D)  $\frac{7}{2}$

8)  $(-1, 2); (-6, -6)$

A)  $-\frac{5}{8}$

B)  $\frac{8}{5}$

C)  $-\frac{8}{5}$

D)  $\frac{5}{8}$

9)  $(-6, 5); (-6, 4)$

A) 0

B) 1

C) -1

D) undefined

10)  $(-5, -6); (1, -6)$

A)  $-\frac{1}{6}$

B) 0

C) 6

D) undefined

## 2 Graph Lines Given a Point and the Slope

MULTIPLE CHOICE. Choose the one alternative that best completes the statement or answers the question.

Graph the line containing the point P and having slope m.

1)  $P = (1, 1)$ ;  $m = \frac{9}{5}$

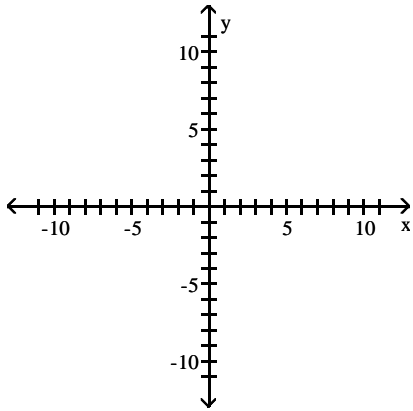

A)

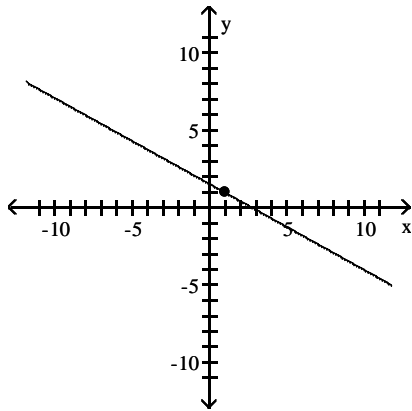

B)

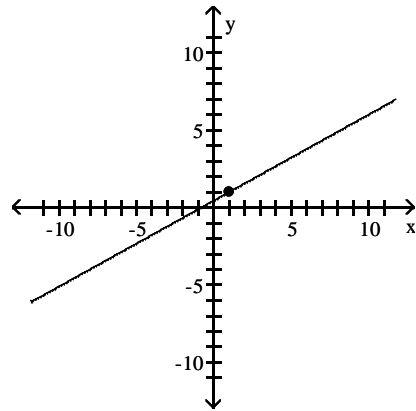

C)

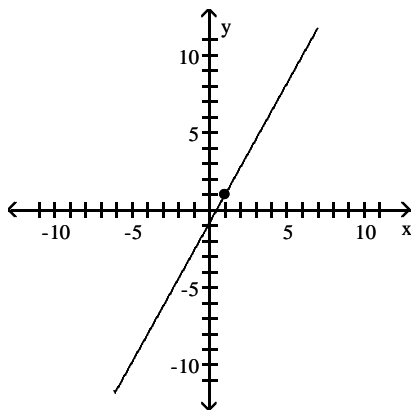

D)

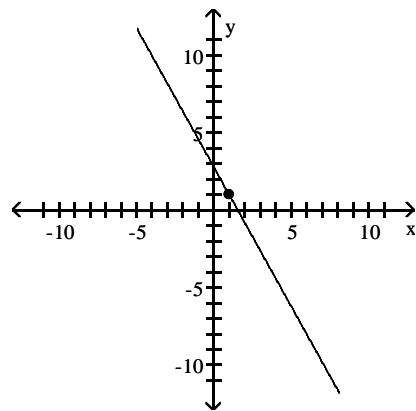

2)  $P = (-2, -8)$ ;  $m = \frac{1}{3}$

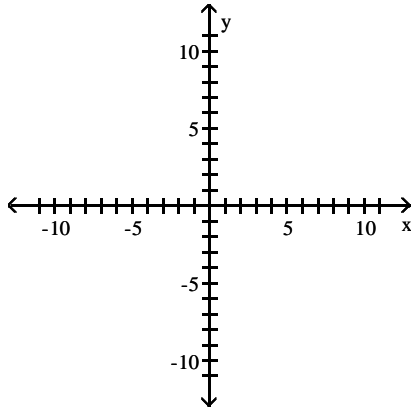

A)

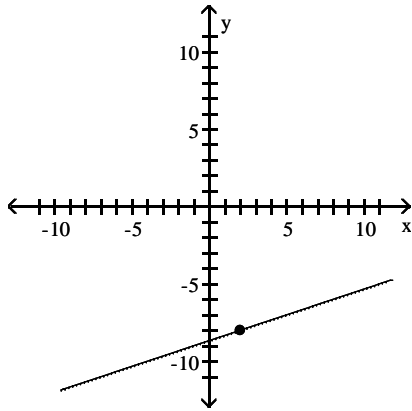

B)

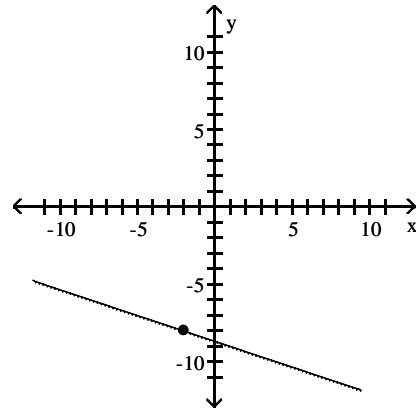

C)

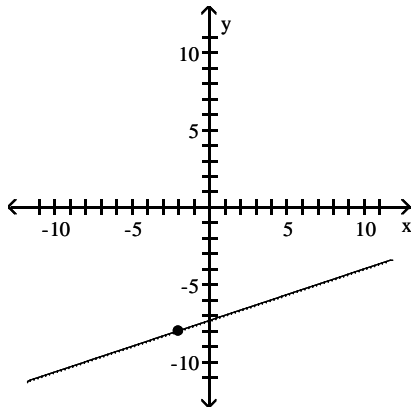

D)

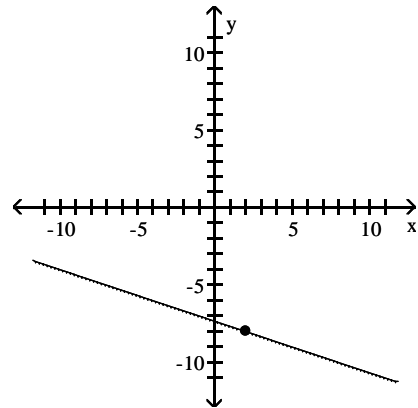

3)  $P = (-2, -2)$ ;  $m = -2$

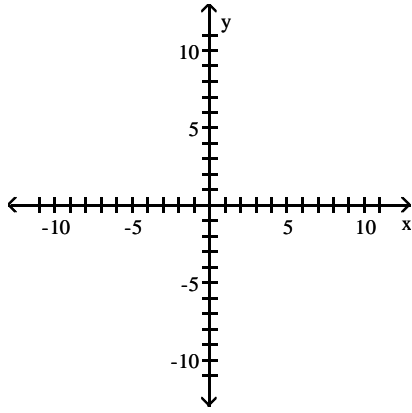

A)

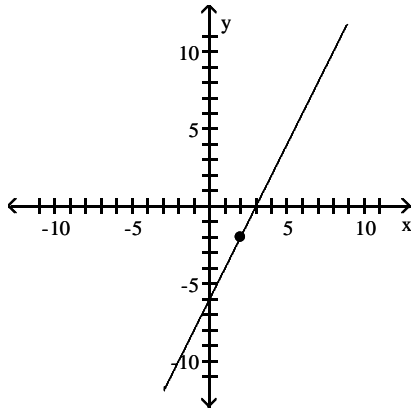

B)

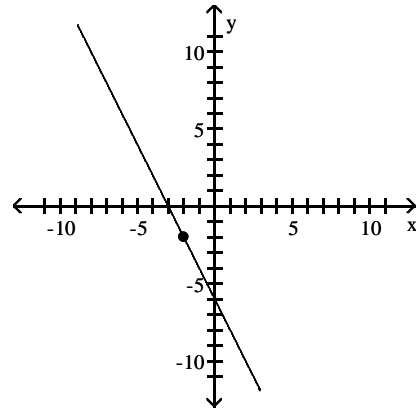

C)

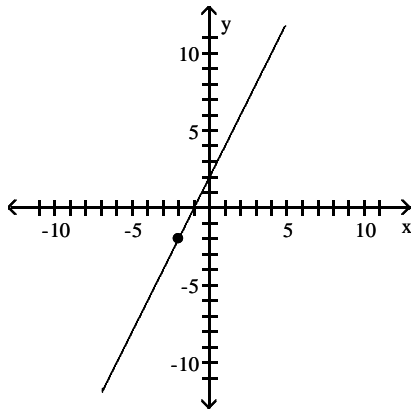

D)

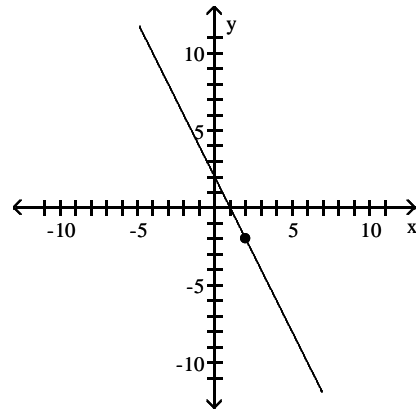

4)  $P = (0, 5)$ ;  $m = 1$

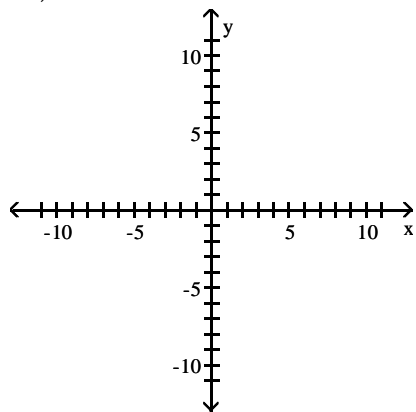

A)

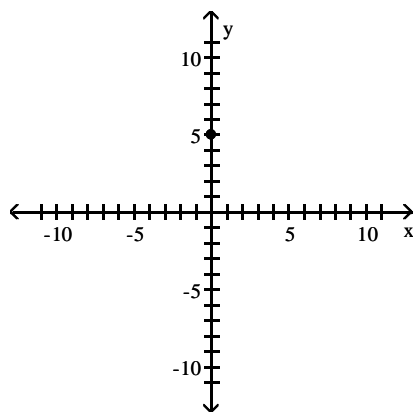

B)

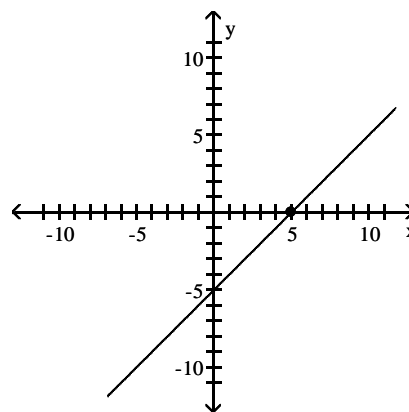

C)

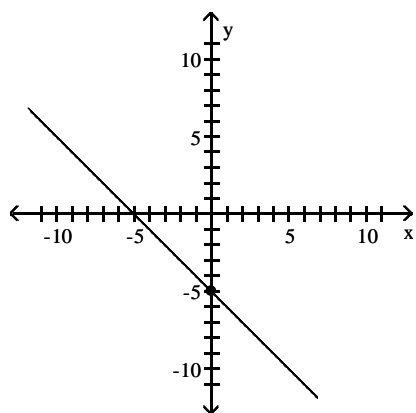

D)

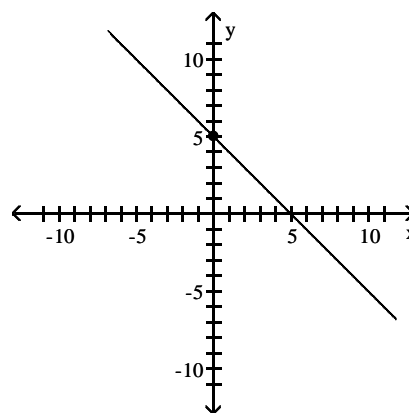

5)  $P = (0, 4)$ ;  $m = -\frac{2}{5}$

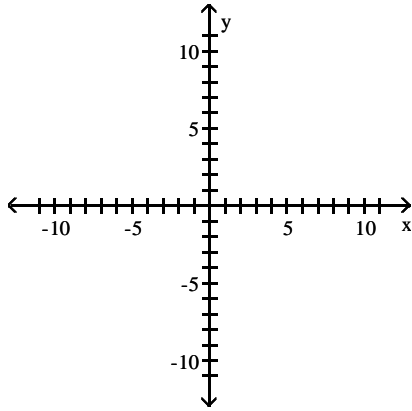

A)

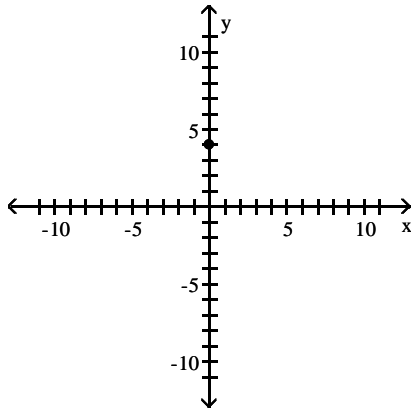

B)

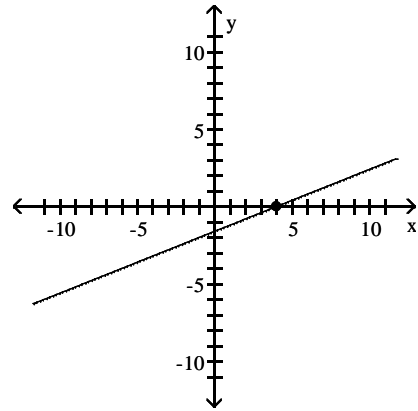

C)

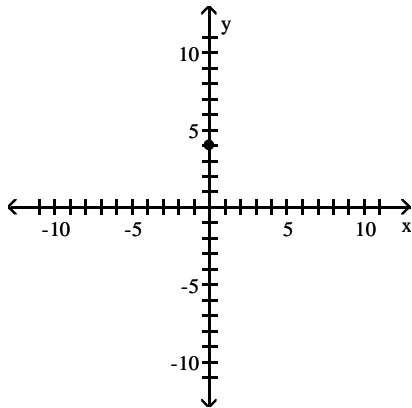

D)

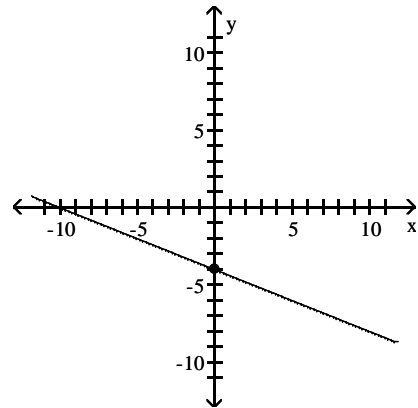

6)  $P = (-2, 0)$ ;  $m = \frac{1}{2}$

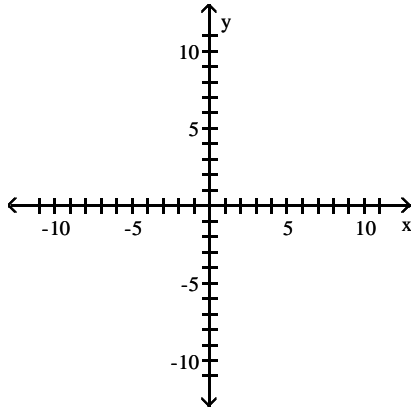

A)

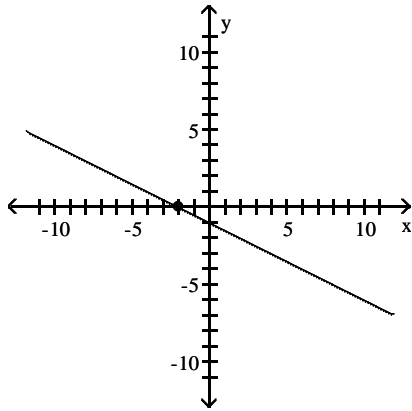

B)

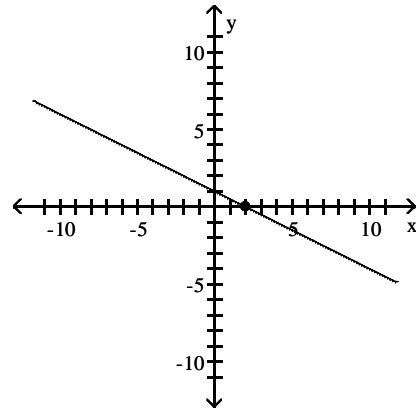

C)

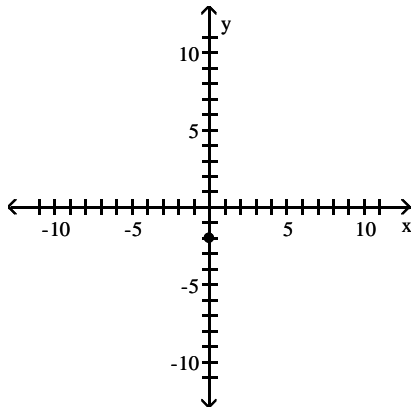

D)

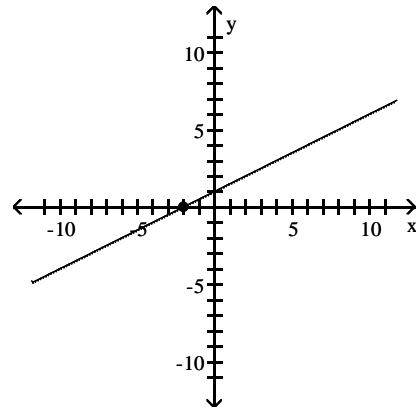

7)  $P = (4, 0)$ ;  $m = -\frac{2}{3}$

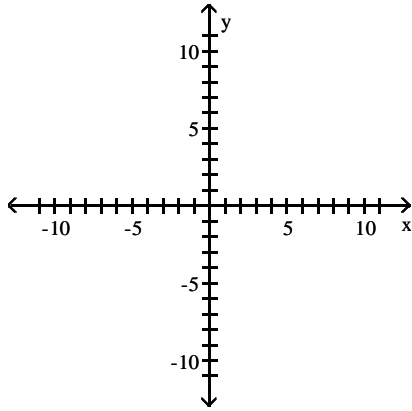

A)

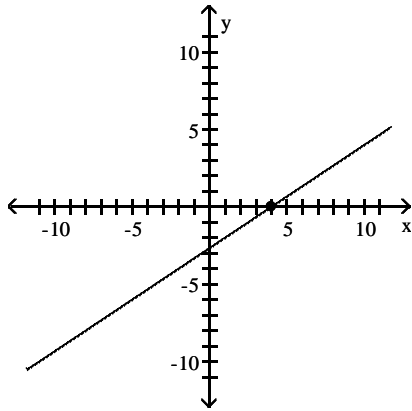

B)

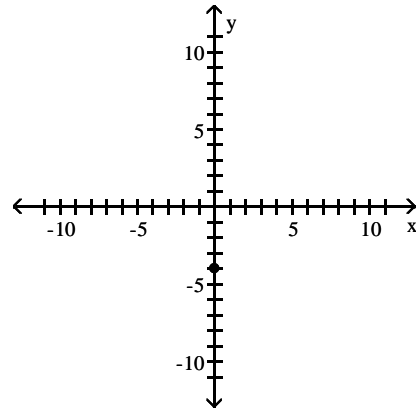

C)

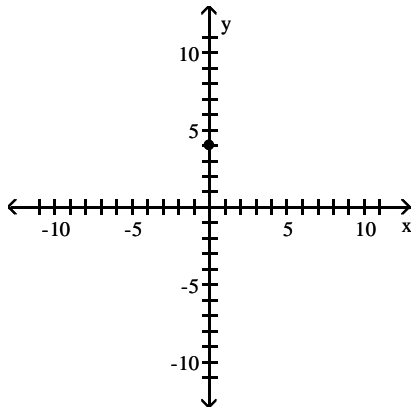

D)

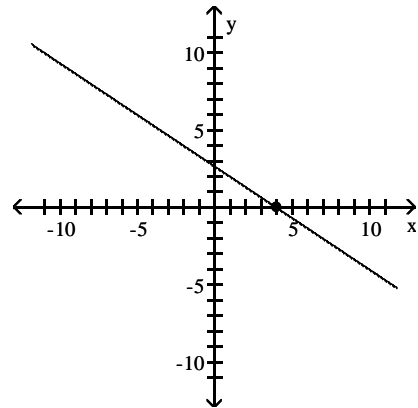



8)  $P = (-9, 4)$ ;  $m = 0$

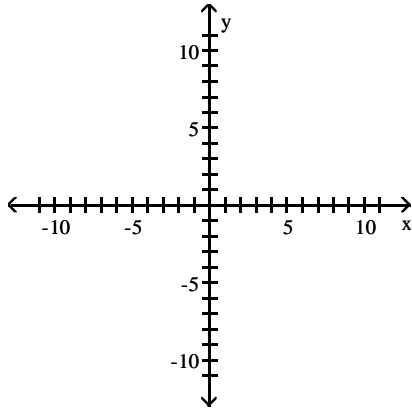

A)

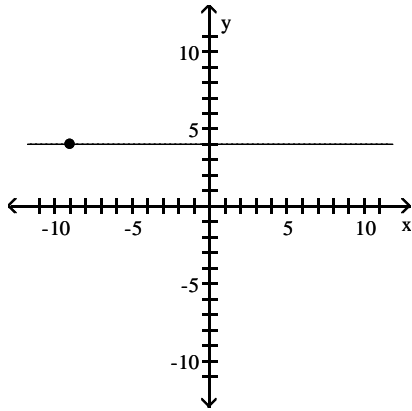

B)

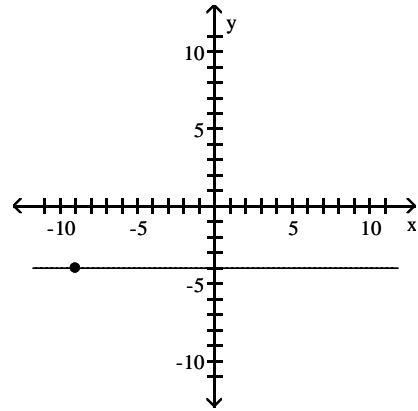

C)

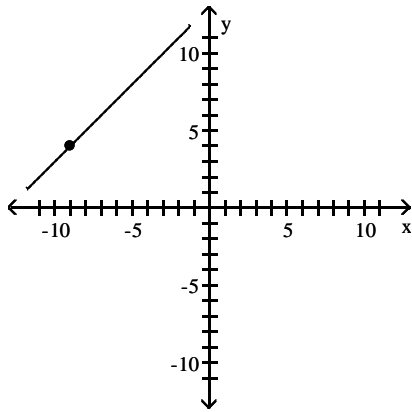

D)

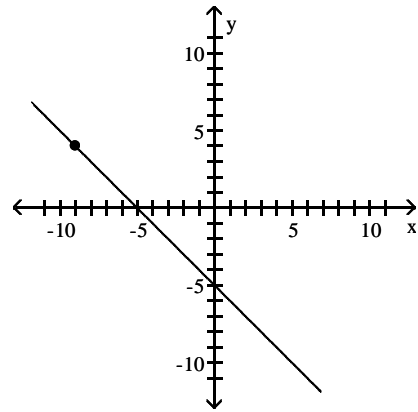

9)  $P = (-1, 6)$ ; slope undefined

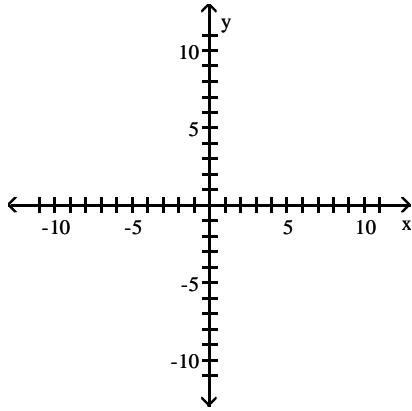

A)

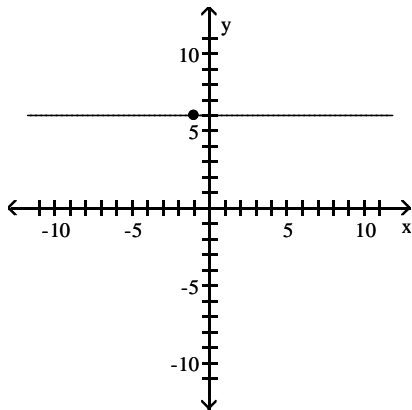

B)

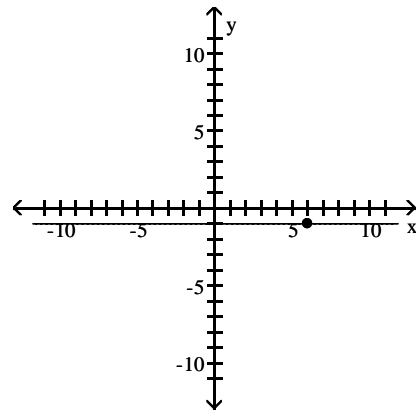

C)

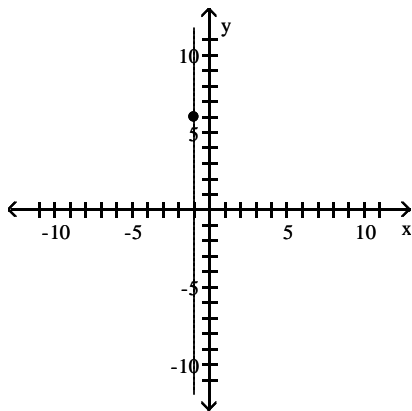

D)

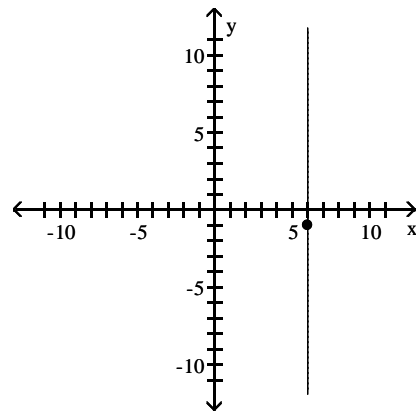

### 3 Find the Equation of a Vertical Line

MULTIPLE CHOICE. Choose the one alternative that best completes the statement or answers the question.

Find an equation for the line with the given properties.

1) Slope undefined; containing the point  $(-5, -2)$

A)  $x = -5$

B)  $y = -2$

C)  $x = -2$

D)  $y = -5$

2) Vertical line; containing the point  $(-2, -1)$

A)  $y = -2$

B)  $y = -1$

C)  $x = -1$

D)  $x = -2$

3) Slope undefined; containing the point  $\left(-\frac{7}{8}, 2\right)$

A)  $x = 2$

B)  $x = -\frac{7}{8}$

C)  $y = -\frac{7}{8}$

D)  $y = 2$

4) Vertical line; containing the point  $(3.6, -5.7)$

A)  $x = -5.7$

B)  $x = 2.1$

C)  $x = 0$

D)  $x = 3.6$

#### 4 Use the Point-Slope Form of a Line; Identify Horizontal Lines

MULTIPLE CHOICE. Choose the one alternative that best completes the statement or answers the question.

Find the slope-intercept form of the equation of the line with the given properties.

1) Horizontal; containing the point  $(-3, 7)$

A)  $y = 7$

B)  $x = -3$

C)  $y = -3$

D)  $x = 7$

2) Slope = 0; containing the point  $(-9, 5)$

A)  $y = 5$

B)  $x = 5$

C)  $x = -9$

D)  $y = -9$

3) Horizontal; containing the point  $\left(-\frac{1}{2}, 5\right)$

A)  $y = -\frac{1}{2}$

B)  $y = -5$

C)  $y = 5$

D)  $y = 0$

4) Horizontal; containing the point  $(0.6, 3.0)$

A)  $y = 3.6$

B)  $y = 0$

C)  $y = 3.0$

D)  $y = 0.6$

Find the slope of the line and sketch its graph.

5)  $y + 1 = 0$

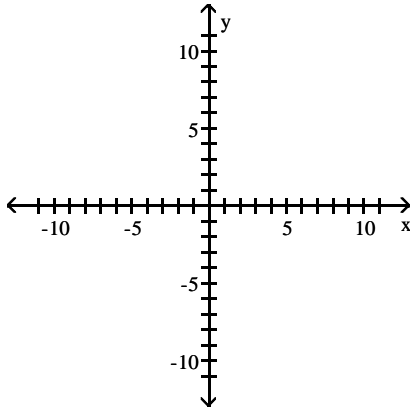

A) slope is undefined

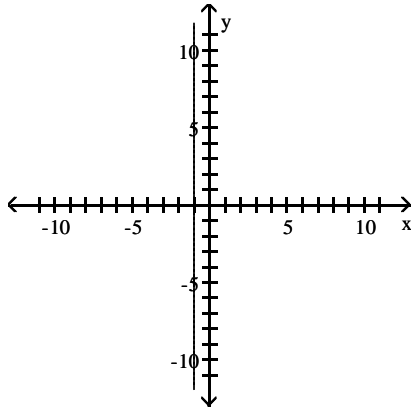

C) slope = 0

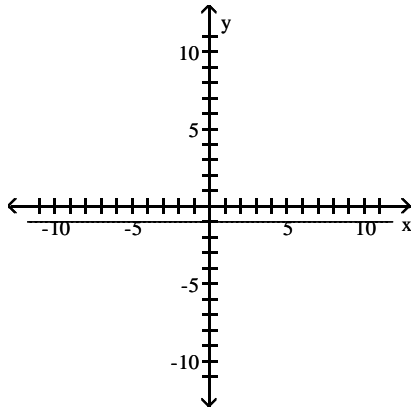

B) slope = - 1

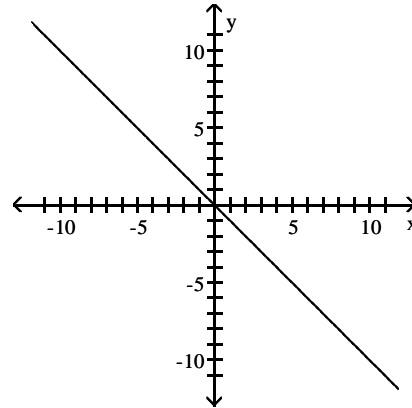

D) slope = -1

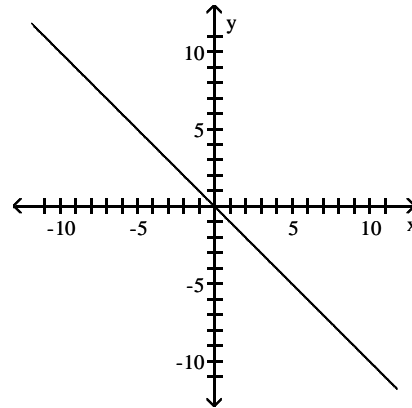

## 5 Find the Equation of a Line Given Two Points

MULTIPLE CHOICE. Choose the one alternative that best completes the statement or answers the question.

Find the equation of the line in slope-intercept form.

1)

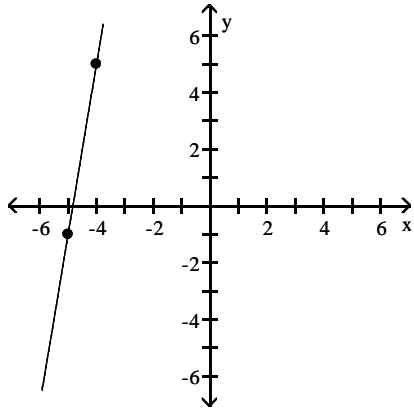

A)  $y = 6x - 26$

B)  $y = 6x - 19$

C)  $y = 6x + 29$

D)  $y = \frac{1}{6}x - \frac{1}{29}$

Find an equation for the line, in the indicated form, with the given properties.

2) Containing the points  $(-2, 6)$  and  $(-4, 3)$ ; slope-intercept form

A)  $y = \frac{3}{2}x + 9$

B)  $y = mx + 9$

C)  $y = -\frac{3}{2}x + 9$

D)  $y - 6 = \frac{3}{2}(x + 2)$

3) Containing the points  $(8, -5)$  and  $(-3, 7)$ ; general form

A)  $-12x + 11y = 41$

B)  $12x + 11y = 41$

C)  $-13x + 10y = -31$

D)  $13x - 10y = -31$

4) Containing the points  $(10, 0)$  and  $(0, -3)$ ; general form

A)  $3x - 10y = 30$

B)  $y = -\frac{3}{10}x + 10$

C)  $y = -\frac{3}{10}x - 3$

D)  $3x + 10y = 30$

5) Containing the points  $(-2, 8)$  and  $(5, -7)$ ; general form

A)  $15x - 7y = -26$

B)  $10x - 12y = -34$

C)  $-10x + 12y = -34$

D)  $-15x - 7y = -26$

6) Containing the points  $(8, -7)$  and  $(0, -4)$ ; general form

A)  $-3x + 8y = -32$

B)  $-15x - 4y = -16$

C)  $3x + 8y = -32$

D)  $15x + 4y = -16$

7) Containing the points  $(-3, 0)$  and  $(8, -9)$ ; general form

A)  $3x - 17y = -129$

B)  $-3x + 17y = -129$

C)  $-9x - 11y = 27$

D)  $9x - 11y = 27$

8) Containing the points  $(-3, 2)$  and  $(2, 9)$ ; general form

A)  $-7x - 5y = -31$

B)  $-5x - 7y = -53$

C)  $5x + 7y = -53$

D)  $7x - 5y = -31$

**Solve.**

9) The relationship between Celsius ( $^{\circ}\text{C}$ ) and Fahrenheit ( $^{\circ}\text{F}$ ) degrees of measuring temperature is linear. Find an equation relating  $^{\circ}\text{C}$  and  $^{\circ}\text{F}$  if  $10^{\circ}\text{C}$  corresponds to  $50^{\circ}\text{F}$  and  $30^{\circ}\text{C}$  corresponds to  $86^{\circ}\text{F}$ . Use the equation to find the Celsius measure of  $33^{\circ}\text{F}$ .

A)  $C = \frac{9}{5}F - 80; -\frac{103}{5}^{\circ}\text{C}$

B)  $C = \frac{5}{9}F + \frac{160}{9}; \frac{325}{9}^{\circ}\text{C}$

C)  $C = \frac{5}{9}F - 10; \frac{25}{3}^{\circ}\text{C}$

D)  $C = \frac{5}{9}F - \frac{160}{9}; \frac{5}{9}^{\circ}\text{C}$

10) A school has just purchased new computer equipment for \$17,000.00. The graph shows the depreciation of the equipment over 5 years. The point (0, 17,000) represents the purchase price and the point (5, 0) represents when the equipment will be replaced. Write a linear equation in slope-intercept form that relates the value of the equipment,  $y$ , to years after purchase  $x$ . Use the equation to predict the value of the equipment after 1 year.

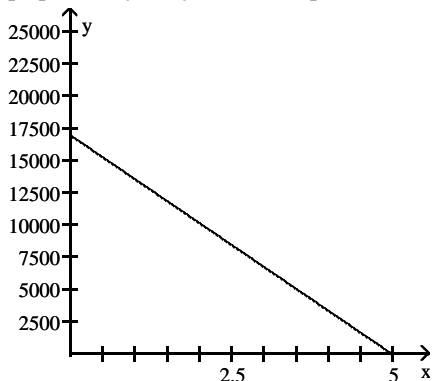

A)  $y = 17,000x + 5;$   
value after 1 years is \$13,600.00

B)  $y = 3400x - 17,000;$   
value after 1 years is \$13,600.00

C)  $y = -17,000x + 17,000;$   
value after 1 years is \$0.00

D)  $y = -3400x + 17,000;$   
value after 1 years is \$13,600.00;

11) The average value of a certain type of automobile was \$15,720 in 1991 and depreciated to \$4800 in 1996. Let  $y$  be the average value of the automobile in the year  $x$ , where  $x = 0$  represents 1991. Write a linear equation that relates the average value of the automobile,  $y$ , to the year  $x$ .

A)  $y = -2184x + 15,720$

B)  $y = -\frac{1}{2184}x - 4800$

C)  $y = -2184x - 6120$

D)  $y = -2184x + 4800$

12) An investment is worth \$2747 in 1991. By 1995 it has grown to \$3791. Let  $y$  be the value of the investment in the year  $x$ , where  $x = 0$  represents 1991. Write a linear equation that relates the value of the investment,  $y$ , to the year  $x$ .

A)  $y = -261x + 2747$

B)  $y = \frac{1}{261}x + 2747$

C)  $y = 261x + 2747$

D)  $y = -261x + 4835$

13) A faucet is used to add water to a large bottle that already contained some water. After it has been filling for 3 seconds, the gauge on the bottle indicates that it contains 16 ounces of water. After it has been filling for 10 seconds, the gauge indicates the bottle contains 44 ounces of water. Let  $y$  be the amount of water in the bottle  $x$  seconds after the faucet was turned on. Write a linear equation that relates the amount of water in the bottle,  $y$ , to the time  $x$ .

A)  $y = 4x + 34$

B)  $y = \frac{1}{4}x + \frac{61}{4}$

C)  $y = -4x + 28$

D)  $y = 4x + 4$

14) When making a telephone call using a calling card, a call lasting 5 minutes cost \$1.45. A call lasting 13 minutes cost \$3.05. Let  $y$  be the cost of making a call lasting  $x$  minutes using a calling card. Write a linear equation that relates the cost of a making a call,  $y$ , to the time  $x$ .

- A)  $y = -0.2x + 2.45$       B)  $y = 0.2x + 0.45$       C)  $y = 0.2x - 9.95$       D)  $y = 5x - \frac{471}{20}$

15) A vendor has learned that, by pricing carmel apples at \$1.50, sales will reach 113 carmel apples per day. Raising the price to \$2.00 will cause the sales to fall to 93 carmel apples per day. Let  $y$  be the number of carmel apples the vendor sells at  $x$  dollars each. Write a linear equation that relates the number of carmel apples sold per day,  $y$ , to the price  $x$ .

- A)  $y = 40x + 53$       B)  $y = -\frac{1}{40}x + \frac{9037}{80}$       C)  $y = -40x - 173$       D)  $y = -40x + 173$

16) A vendor has learned that, by pricing caramel apples at \$1.25, sales will reach 110 caramel apples per day. Raising the price to \$2.25 will cause the sales to fall to 58 caramel apples per day. Let  $y$  be the number of caramel apples the vendor sells at  $x$  dollars each. Write a linear equation that relates the number of caramel apples sold per day to the price  $x$ .

- A)  $y = -52x + 175$       B)  $y = -52x - 175$       C)  $y = -\frac{1}{52}x + \frac{22875}{208}$       D)  $y = 52x + 45$

## 6 Write the Equation of a Line in Slope-Intercept Form

MULTIPLE CHOICE. Choose the one alternative that best completes the statement or answers the question.

**Find the slope-intercept form of the equation of the line with the given properties.**

1) Slope = 2; containing the point  $(-4, -3)$

- A)  $y = -2x + 5$       B)  $y = 2x + 5$       C)  $y = -2x - 5$       D)  $y = 2x - 5$

2) Slope = 0; containing the point  $(-1, 5)$

- A)  $y = -1$       B)  $x = 5$       C)  $y = 5$       D)  $x = -1$

3) Slope = -9; y-intercept = 20

- A)  $y = 20x - 9$       B)  $y = -9x - 20$       C)  $y = -9x + 20$       D)  $y = 20x + 9$

4) x-intercept = 5; y-intercept = 6

- A)  $y = \frac{6}{5}x + 6$       B)  $y = -\frac{5}{6}x + 5$       C)  $y = -\frac{6}{5}x + 6$       D)  $y = -\frac{6}{5}x + 5$

**Write the equation in slope-intercept form.**

5)  $16x + 5y = 3$

- A)  $y = -\frac{16}{5}x + \frac{3}{5}$       B)  $y = \frac{16}{5}x + \frac{3}{5}$       C)  $y = \frac{16}{5}x - \frac{3}{5}$       D)  $y = 16x - 3$

6)  $6x + 5y = 2$

- A)  $y = \frac{5}{6}x - \frac{2}{6}$       B)  $y = \frac{12}{5}x + \frac{2}{5}$       C)  $y = \frac{6}{5}x + \frac{2}{5}$       D)  $y = 6x + 12$

7)  $8x - 5y = 8$

- A)  $y = 8x - 8$       B)  $y = \frac{5}{8}x + \frac{8}{8}$       C)  $y = \frac{8}{5}x + \frac{8}{5}$       D)  $y = \frac{8}{5}x - \frac{8}{5}$

8)  $x = 7y + 3$

A)  $y = \frac{1}{7}x - 3$

B)  $y = \frac{1}{7}x - \frac{3}{7}$

C)  $y = x - \frac{3}{7}$

D)  $y = 7x - 3$

**Solve.**

9) A truck rental company rents a moving truck one day by charging \$29 plus \$0.09 per mile. Write a linear equation that relates the cost  $C$ , in dollars, of renting the truck to the number  $x$  of miles driven. What is the cost of renting the truck if the truck is driven 160 miles?

A)  $C = 0.09x + 29$ ; \$43.40

B)  $C = 0.09x - 29$ ; \$14.60

C)  $C = 29x + 0.09$ ; \$4640.09

D)  $C = 0.09x + 29$ ; \$30.44

10) Each week a soft drink machine sells  $x$  cans of soda for \$0.75/soda. The cost to the owner of the soda machine for each soda is \$0.10. The weekly fixed cost for maintaining the soda machine is \$25/week. Write an equation that relates the weekly profit,  $P$ , in dollars to the number of cans sold each week. Then use the equation to find the weekly profit when 92 cans of soda are sold in a week.

A)  $P = 0.75x - 25$ ; \$44.00

B)  $P = 0.65x - 25$ ; \$34.80

C)  $P = 0.65x + 25$ ; \$84.80

D)  $P = 0.75x + 25$ ; \$94.00

11) Each day the commuter train transports  $x$  passengers to or from the city at \$1.75/passenger. The daily fixed cost for running the train is \$1200. Write an equation that relates the daily profit,  $P$ , in dollars to the number of passengers each day. Then use the equation to find the daily profit when the train has 920 passengers in a day.

A)  $P = 1.75x - 1200$ ; \$410

B)  $P = 1.75x$ ; \$1610

C)  $P = 1.75x + 1200$ ; \$2810

D)  $P = 1200 - 1.75x$ ; \$410

12) Each month a beauty salon gives  $x$  manicures for \$12.00/manicure. The cost to the owner of the beauty salon for each manicure is \$7.35. The monthly fixed cost to maintain a manicure station is \$120.00. Write an equation that relates the monthly profit, in dollars, to the number of manicures given each month. Then use the equation to find the monthly profit when 200 manicures are given in a month.

A)  $P = 7.35x - 120$ ; \$1350

B)  $P = 4.65x$ ; \$930

C)  $P = 4.65x - 120$ ; \$810

D)  $P = 12x - 120$ ; \$2280

13) Each month a gas station sells  $x$  gallons of gas at \$1.92/gallon. The cost to the owner of the gas station for each gallon of gas is \$1.32. The monthly fixed cost for running the gas station is \$37,000. Write an equation that relates the monthly profit, in dollars, to the number of gallons of gasoline sold. Then use the equation to find the monthly profit when 75,000 gallons of gas are sold in a month.

A)  $P = 1.92x - 37,000$ ; \$107,000

B)  $P = 0.60x - 37,000$ ; \$8000

C)  $P = 0.60x + 37,000$ ; \$82,000

D)  $P = 1.32x - 37,000$ ; \$62,000

## 7 Identify the Slope and $y$ -Intercept of a Line from Its Equation

MULTIPLE CHOICE. Choose the one alternative that best completes the statement or answers the question.

**Find the slope and  $y$ -intercept of the line.**

1)  $y = -\frac{6}{7}x + 1$

A) slope =  $\frac{6}{7}$ ;  $y$ -intercept =  $-1$

B) slope =  $1$ ;  $y$ -intercept =  $-\frac{6}{7}$

C) slope =  $-\frac{6}{7}$ ;  $y$ -intercept =  $1$

D) slope =  $-\frac{7}{6}$ ;  $y$ -intercept =  $-1$

2)  $x + y = 7$

A) slope =  $-1$ ;  $y$ -intercept =  $7$

B) slope =  $-1$ ;  $y$ -intercept =  $-7$

C) slope =  $1$ ;  $y$ -intercept =  $7$

D) slope =  $0$ ;  $y$ -intercept =  $7$



3)  $7x + y = -3$

A) slope =  $-\frac{1}{7}$ ; y-intercept =  $-\frac{3}{7}$

C) slope =  $-\frac{7}{3}$ ; y-intercept =  $-\frac{1}{3}$

B) slope = 7; y-intercept = -3

D) slope = -7; y-intercept = -3

4)  $-6x + 5y = 8$

A) slope =  $\frac{6}{5}$ ; y-intercept =  $\frac{8}{5}$

C) slope =  $\frac{12}{5}$ ; y-intercept =  $\frac{8}{5}$

B) slope =  $\frac{5}{6}$ ; y-intercept =  $-\frac{8}{6}$

D) slope = 6; y-intercept = 12

5)  $9x + 7y = 19$

A) slope = 9; y-intercept = 19

C) slope =  $\frac{9}{7}$ ; y-intercept =  $-\frac{19}{7}$

B) slope =  $-\frac{9}{7}$ ; y-intercept =  $\frac{19}{7}$

D) slope =  $\frac{9}{7}$ ; y-intercept =  $\frac{19}{7}$

6)  $5x - 7y = 6$

A) slope =  $\frac{5}{7}$ ; y-intercept =  $\frac{6}{7}$

C) slope =  $\frac{7}{5}$ ; y-intercept =  $\frac{6}{5}$

B) slope = 5; y-intercept = 6

D) slope =  $\frac{5}{7}$ ; y-intercept =  $-\frac{6}{7}$

7)  $12x - 6y = 72$

A) slope = 2; y-intercept = -12

C) slope = 12; y-intercept = 72

B) slope =  $\frac{1}{2}$ ; y-intercept = 6

D) slope = -2; y-intercept = 12

8)  $x + 13y = 1$

A) slope = -13; y-intercept = 13

C) slope =  $-\frac{1}{13}$ ; y-intercept =  $\frac{1}{13}$

B) slope =  $\frac{1}{13}$ ; y-intercept =  $\frac{1}{13}$

D) slope = 1; y-intercept = 1

9)  $-x + 2y = 18$

A) slope =  $\frac{1}{2}$ ; y-intercept = 9

C) slope = 2; y-intercept = -18

B) slope = -1; y-intercept = 18

D) slope =  $-\frac{1}{2}$ ; y-intercept = 9

10)  $y = -3$

A) slope = 0; no y-intercept

C) slope = 0; y-intercept = -3

B) slope = -3; y-intercept = 0

D) slope = 1; y-intercept = -3

11)  $x = 3$

A) slope = 3; y-intercept = 0

C) slope undefined; y-intercept = 3

B) slope undefined; no y-intercept

D) slope = 0; y-intercept = 3

12)  $y = 3x$

A) slope = 0; y-intercept = 3

B) slope = 3; y-intercept = 0

C) slope = -3; y-intercept = 0

D) slope =  $\frac{1}{3}$ ; y-intercept = 0

### 8 Graph Lines Written in General Form Using Intercepts

MULTIPLE CHOICE. Choose the one alternative that best completes the statement or answers the question.

Find the general form of the equation for the line with the given properties.

1) Slope =  $\frac{3}{5}$ ; y-intercept =  $\frac{9}{5}$

A)  $3x - 5y = -9$

B)  $y = \frac{3}{5}x - \frac{9}{5}$

C)  $y = \frac{3}{5}x + \frac{9}{5}$

D)  $3x + 5y = -9$

2) Slope =  $-\frac{3}{5}$ ; containing the point (2, 4)

A)  $3x + 5y = 26$

B)  $3x + 5y = -26$

C)  $3x - 5y = 26$

D)  $5x + 3y = -26$

3) Slope =  $-\frac{4}{5}$ ; containing the point (0, 4)

A)  $4x - 5y = 20$

B)  $5x + 4y = -20$

C)  $4x + 5y = 20$

D)  $4x + 5y = -20$

4) Slope =  $\frac{2}{9}$ ; containing (0, 2)

A)  $9x - 2y = -18$

B)  $-2x + 9y = -18$

C)  $-2x - 9y = 18$

D)  $-2x + 9y = 18$

Find the slope of the line and sketch its graph.

5)  $4x + 5y = 18$

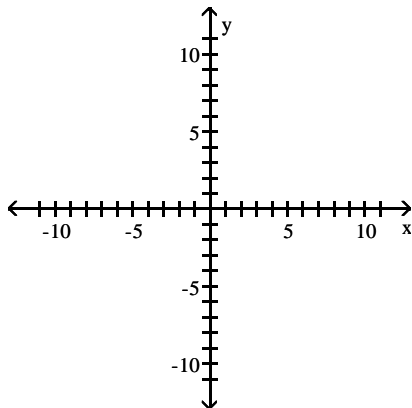

A) slope =  $-\frac{5}{4}$

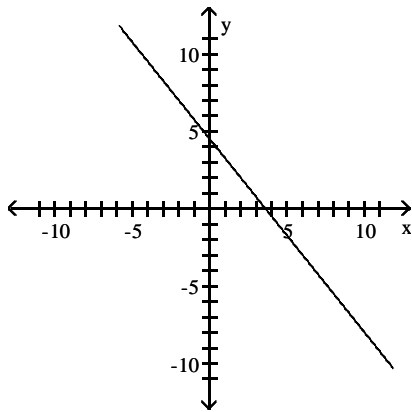

B) slope =  $\frac{5}{4}$

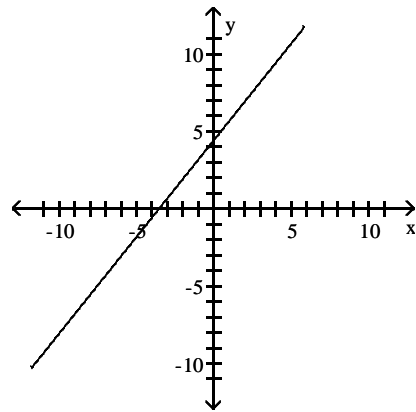

C) slope =  $\frac{4}{5}$

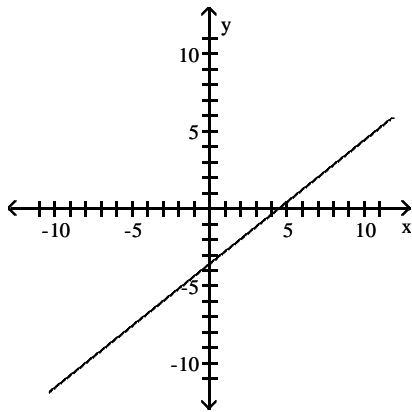

D) slope =  $-\frac{4}{5}$

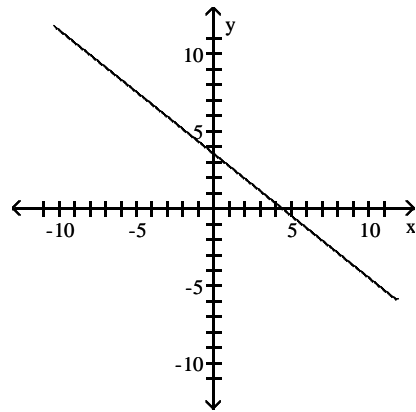

6)  $3x - 5y = -9$

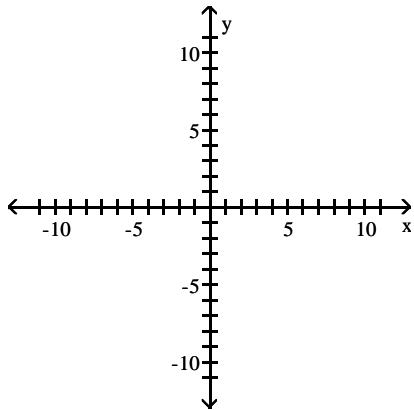

A) slope =  $-\frac{3}{5}$

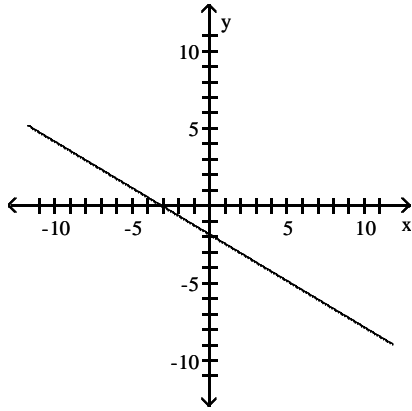

B) slope =  $\frac{3}{5}$

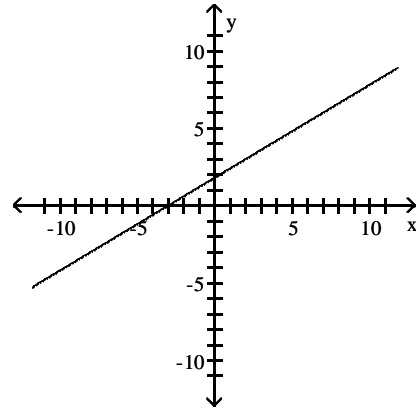

C) slope =  $\frac{5}{3}$

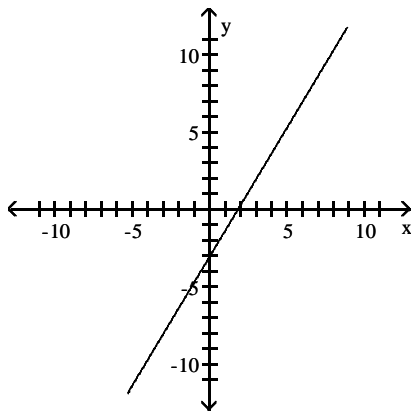

D) slope =  $-\frac{5}{3}$

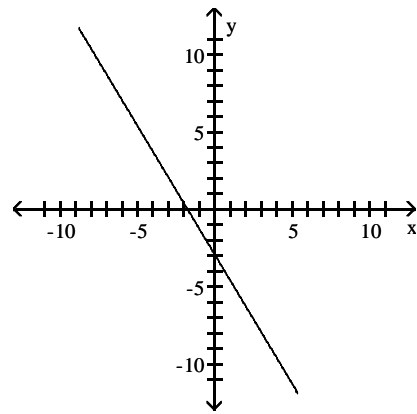

**Solve the problem.**

7) Find an equation in general form for the line graphed on a graphing utility.

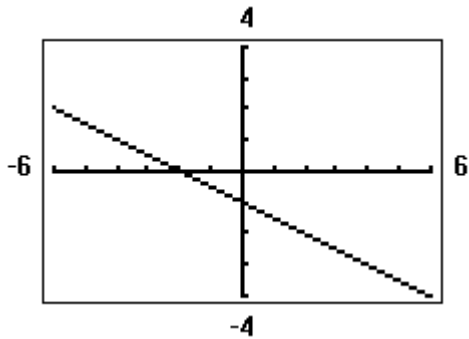

A)  $2x + y = -1$

B)  $y = -2x - 1$

C)  $y = -\frac{1}{2}x - 1$

D)  $x + 2y = -2$

## 9 Find Equations of Parallel Lines

MULTIPLE CHOICE. Choose the one alternative that best completes the statement or answers the question.

**Find an equation for the line with the given properties.**

- 1) The solid line L contains the point  $(2, -1)$  and is parallel to the dotted line whose equation is  $y = 2x$ . Give the equation for the line L in slope-intercept form.

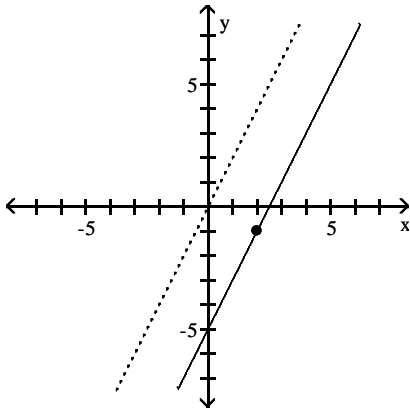

- A)  $y + 1 = 2(x - 2)$       B)  $y = 2x + b$       C)  $y = 2x - 3$       D)  $y = 2x - 5$
- 2) Parallel to the line  $y = 4x$ ; containing the point  $(8, 5)$   
 A)  $y - 5 = 4x - 8$       B)  $y = 4x - 27$       C)  $y = 4x + 27$       D)  $y = 4x$
- 3) Parallel to the line  $x + 5y = 4$ ; containing the point  $(0, 0)$   
 A)  $y = -\frac{1}{5}x$       B)  $y = \frac{1}{5}x$       C)  $y = \frac{3}{5}$       D)  $y = -\frac{1}{5}x + 4$
- 4) Parallel to the line  $-2x - y = 5$ ; containing the point  $(0, 0)$   
 A)  $y = \frac{1}{2}x + 5$       B)  $y = -\frac{1}{2}x$       C)  $y = \frac{1}{2}x$       D)  $y = -2x$
- 5) Parallel to the line  $y = 4$ ; containing the point  $(9, 1)$   
 A)  $y = 1$       B)  $y = 4$       C)  $y = 9$       D)  $y = -1$
- 6) Parallel to the line  $x = -2$ ; containing the point  $(7, 8)$   
 A)  $y = -2$       B)  $y = 8$       C)  $x = 7$       D)  $x = 8$
- 7) Parallel to the line  $9x + 5y = 14$ ; containing the point  $(6, -17)$   
 A)  $6x + 5y = 14$       B)  $9x + 5y = -31$       C)  $5x + 9y = -17$       D)  $9x - 5y = -31$
- 8) Parallel to the line  $5x + 6y = 4$ ; x-intercept = 2  
 A)  $5x + 6y = 10$       B)  $6x - 5y = -10$       C)  $5x + 6y = 12$       D)  $6x - 5y = 12$

## 10 Find Equations of Perpendicular Lines

MULTIPLE CHOICE. Choose the one alternative that best completes the statement or answers the question.

**Find an equation for the line with the given properties.**

- 1) The solid line L contains the point (4, 1) and is perpendicular to the dotted line whose equation is  $y = 2x$ . Give the equation of line L in slope-intercept form.

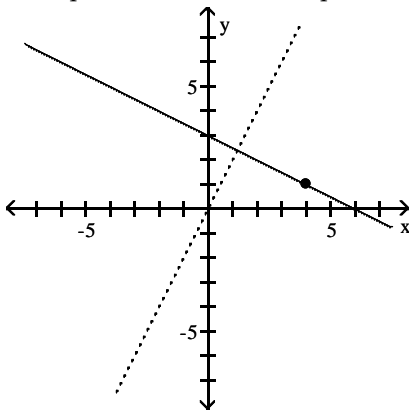

- A)  $y - 1 = -\frac{1}{2}(x - 4)$       B)  $y = -\frac{1}{2}x + 3$       C)  $y - 1 = 2(x - 4)$       D)  $y = \frac{1}{2}x + 3$
- 2) Perpendicular to the line  $y = 3x - 1$ ; containing the point  $(-4, 1)$
- A)  $y = -\frac{1}{3}x - \frac{1}{3}$       B)  $y = -3x - \frac{1}{3}$       C)  $y = \frac{1}{3}x - \frac{1}{3}$       D)  $y = 3x - \frac{1}{3}$
- 3) Perpendicular to the line  $y = \frac{1}{2}x + 9$ ; containing the point  $(5, -4)$
- A)  $y = 2x - 6$       B)  $y = -\frac{1}{2}x - 3$       C)  $y = -2x + 6$       D)  $y = -2x - 6$
- 4) Perpendicular to the line  $-4x - y = 8$ ; containing the point  $(0, -2)$
- A)  $y = \frac{1}{4}x + 8$       B)  $y = \frac{1}{4}x - 2$       C)  $y = -\frac{1}{4}x - 2$       D)  $y = -\frac{7}{4}$
- 5) Perpendicular to the line  $x - 2y = 7$ ; containing the point  $(5, 4)$
- A)  $y = -2x - 14$       B)  $y = -\frac{1}{2}x - 7$       C)  $y = 2x - 14$       D)  $y = -2x + 14$
- 6) Perpendicular to the line  $y = -4$ ; containing the point  $(7, 8)$
- A)  $y = 7$       B)  $x = 8$       C)  $x = 7$       D)  $y = 8$
- 7) Perpendicular to the line  $x = 3$ ; containing the point  $(4, 8)$
- A)  $x = 8$       B)  $y = 8$       C)  $x = 4$       D)  $y = 4$
- 8) Perpendicular to the line  $8x - 3y = 39$ ; containing the point  $(3, 5)$
- A)  $3x + 3y = 39$       B)  $3x - 8y = 49$       C)  $8x + 3 = 8$       D)  $3x + 8y = 49$
- 9) Perpendicular to the line  $7x - 8y = 19$ ; containing the point  $(-3, -11)$
- A)  $-8x + 7y = 19$       B)  $-8x - 7y = 101$       C)  $-8x + 7y = 101$       D)  $7x + 8y = 101$
- 10) Perpendicular to the line  $2x + 3y = 1$ ;  $y$ -intercept = 4
- A)  $3x - 2y = 12$       B)  $3x - 2y = -8$       C)  $2x + 3y = 8$       D)  $2x + 3y = 12$

Decide whether the pair of lines is parallel, perpendicular, or neither.

11)  $3x - 2y = 6$

$2x + 3y = 10$

A) parallel

B) perpendicular

C) neither

12)  $3x - 4y = -18$

$8x + 6y = 7$

A) parallel

B) perpendicular

C) neither

13)  $12x + 4y = 16$

$21x + 7y = 29$

A) parallel

B) perpendicular

C) neither

## 2.4 Circles

### 1 Write the Standard Form of the Equation of a Circle

MULTIPLE CHOICE. Choose the one alternative that best completes the statement or answers the question.

Write the standard form of the equation of the circle.

1)

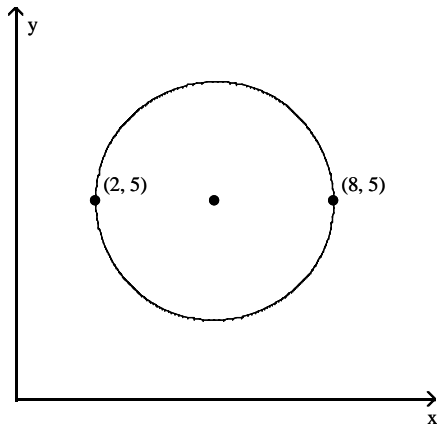

A)  $(x - 5)^2 + (y - 5)^2 = 9$

B)  $(x + 5)^2 + (y + 5)^2 = 3$

C)  $(x + 5)^2 + (y + 5)^2 = 9$

D)  $(x - 5)^2 + (y - 5)^2 = 3$

2)

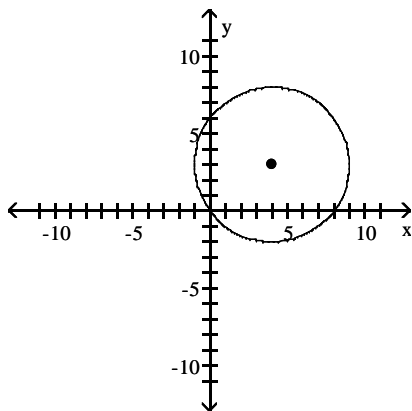

A)  $(x + 4)^2 + (y + 3)^2 = 25$

B)  $(x + 3)^2 + (y + 4)^2 = 25$

C)  $(x - 3)^2 + (y - 4)^2 = 25$

D)  $(x - 4)^2 + (y - 3)^2 = 25$

Write the standard form of the equation of the circle with radius  $r$  and center  $(h, k)$ .

3)  $r = 2$ ;  $(h, k) = (0, 0)$

A)  $(x - 2)^2 + (y - 2)^2 = 2$

C)  $x^2 + y^2 = 4$

B)  $(x - 2)^2 + (y - 2)^2 = 4$

D)  $x^2 + y^2 = 2$

4)  $r = 3$ ;  $(h, k) = (-6, 2)$

A)  $(x - 6)^2 + (y + 2)^2 = 3$

C)  $(x + 6)^2 + (y - 2)^2 = 3$

B)  $(x - 6)^2 + (y + 2)^2 = 9$

D)  $(x + 6)^2 + (y - 2)^2 = 9$

5)  $r = 8$ ;  $(h, k) = (-8, 0)$

A)  $x^2 + (y - 8)^2 = 8$

B)  $x^2 + (y + 8)^2 = 8$

C)  $(x - 8)^2 + y^2 = 64$

D)  $(x + 8)^2 + y^2 = 64$

6)  $r = 6$ ;  $(h, k) = (0, -2)$

A)  $(x + 2)^2 + y^2 = 36$

B)  $(x - 2)^2 + y^2 = 36$

C)  $x^2 + (y - 2)^2 = 6$

D)  $x^2 + (y + 2)^2 = 36$

7)  $r = \sqrt{5}$ ;  $(h, k) = (1, 4)$

A)  $(x + 4)^2 + (y + 1)^2 = 25$

C)  $(x - 4)^2 + (y - 1)^2 = 25$

B)  $(x + 1)^2 + (y + 4)^2 = 5$

D)  $(x - 1)^2 + (y - 4)^2 = 5$

8)  $r = \sqrt{5}$ ;  $(h, k) = (0, 6)$

A)  $x^2 + (y + 6)^2 = 5$

B)  $(x - 6)^2 + y^2 = 25$

C)  $x^2 + (y - 6)^2 = 5$

D)  $(x + 6)^2 + y^2 = 25$

Solve the problem.

9) Find the equation of a circle in standard form where  $C(6, -2)$  and  $D(-4, 4)$  are endpoints of a diameter.

A)  $(x + 1)^2 + (y + 1)^2 = 136$

B)  $(x - 1)^2 + (y - 1)^2 = 136$

C)  $(x + 1)^2 + (y + 1)^2 = 34$

D)  $(x - 1)^2 + (y - 1)^2 = 34$

10) Find the equation of a circle in standard form with center at the point  $(-3, 2)$  and tangent to the line  $y = 4$ .

A)  $(x - 3)^2 + (y + 2)^2 = 4$

B)  $(x + 3)^2 + (y - 2)^2 = 4$

C)  $(x + 3)^2 + (y - 2)^2 = 16$

D)  $(x - 3)^2 + (y + 2)^2 = 16$

11) Find the equation of a circle in standard form that is tangent to the line  $x = -3$  at  $(-3, 5)$  and also tangent to the line  $x = 9$ .

A)  $(x - 3)^2 + (y + 5)^2 = 36$

B)  $(x - 3)^2 + (y - 5)^2 = 36$

C)  $(x + 3)^2 + (y + 5)^2 = 36$

D)  $(x + 3)^2 + (y - 5)^2 = 36$

Find the center  $(h, k)$  and radius  $r$  of the circle with the given equation.

12)  $x^2 + y^2 = 4$

A)  $(h, k) = (0, 0)$ ;  $r = 4$

C)  $(h, k) = (2, 2)$ ;  $r = 4$

B)  $(h, k) = (2, 2)$ ;  $r = 2$

D)  $(h, k) = (0, 0)$ ;  $r = 2$

13)  $(x + 6)^2 + (y + 8)^2 = 49$

A)  $(h, k) = (-6, -8)$ ;  $r = 49$

C)  $(h, k) = (-8, -6)$ ;  $r = 49$

B)  $(h, k) = (-6, -8)$ ;  $r = 7$

D)  $(h, k) = (-8, -6)$ ;  $r = 7$

14)  $(x + 5)^2 + y^2 = 16$

A)  $(h, k) = (0, -5)$ ;  $r = 4$

C)  $(h, k) = (-5, 0)$ ;  $r = 16$

B)  $(h, k) = (0, -5)$ ;  $r = 16$

D)  $(h, k) = (-5, 0)$ ;  $r = 4$



15)  $x^2 + (y + 4)^2 = 25$

- A)  $(h, k) = (0, -4); r = 5$   
 C)  $(h, k) = (0, -4); r = 25$

- B)  $(h, k) = (-4, 0); r = 5$   
 D)  $(h, k) = (-4, 0); r = 25$

16)  $2(x + 4)^2 + 2(y + 1)^2 = 28$

- A)  $(h, k) = (-4, -1); r = \sqrt{14}$   
 C)  $(h, k) = (-4, -1); r = 2\sqrt{14}$

- B)  $(h, k) = (4, 1); r = \sqrt{14}$   
 D)  $(h, k) = (4, 1); r = 2\sqrt{14}$

**Solve the problem.**

17) Find the standard form of the equation of the circle. Assume that the center has integer coordinates and the radius is an integer.

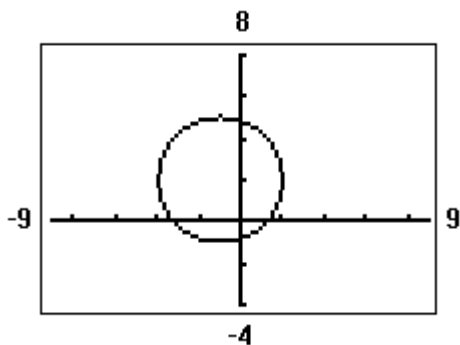

- A)  $x^2 + y^2 + 2x - 4y - 4 = 0$   
 C)  $(x + 1)^2 + (y - 2)^2 = 9$

- B)  $(x - 1)^2 + (y + 2)^2 = 9$   
 D)  $x^2 + y^2 - 2x + 4y - 4 = 0$

## 2 Graph a Circle

MULTIPLE CHOICE. Choose the one alternative that best completes the statement or answers the question.

Graph the circle with radius  $r$  and center  $(h, k)$ .

1)  $r = 2$ ;  $(h, k) = (0, 0)$

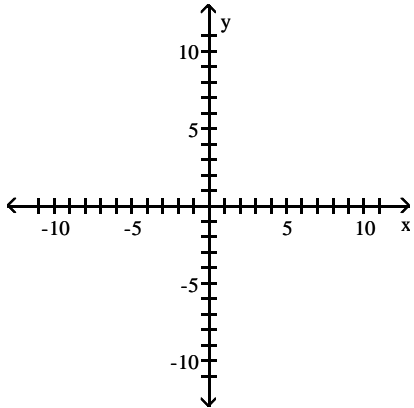

A)

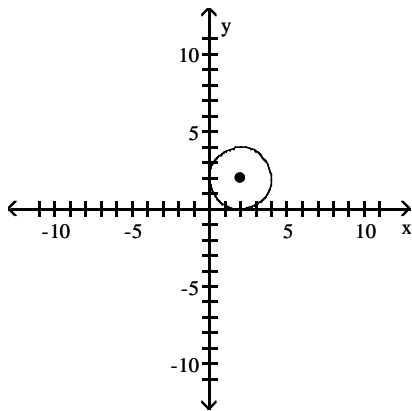

B)

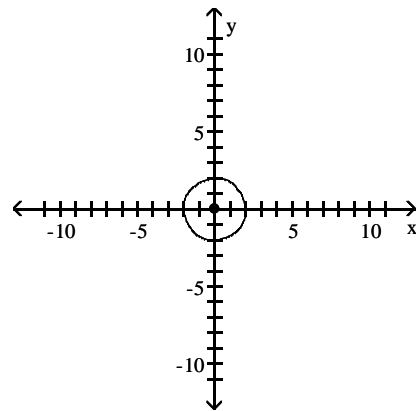

C)

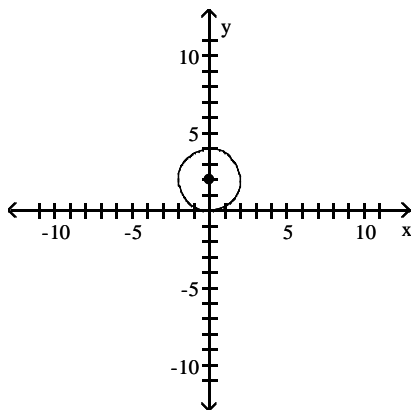

D)

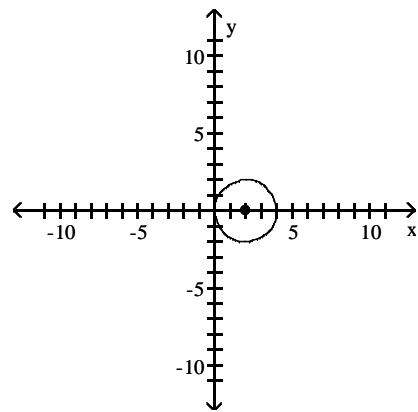

2)  $r = 4$ ;  $(h, k) = (0, 4)$

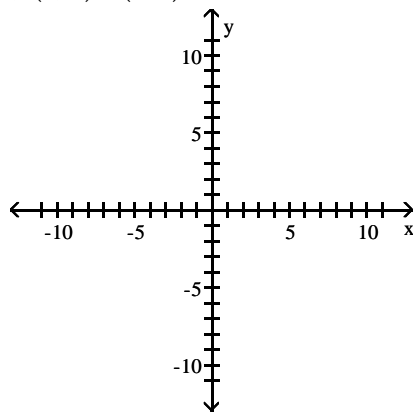

A)

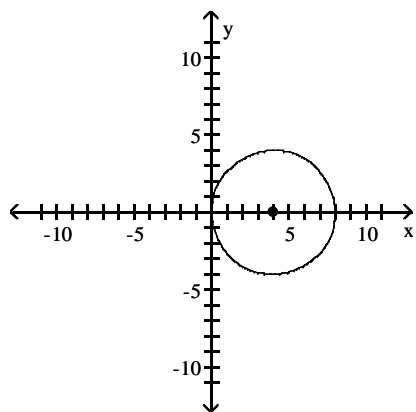

B)

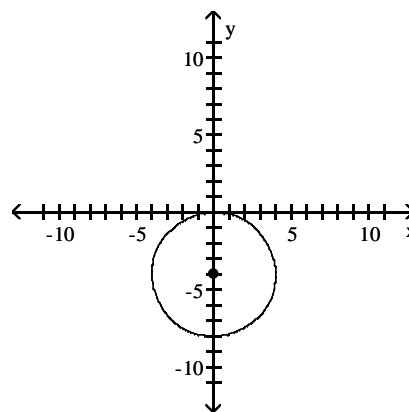

C)

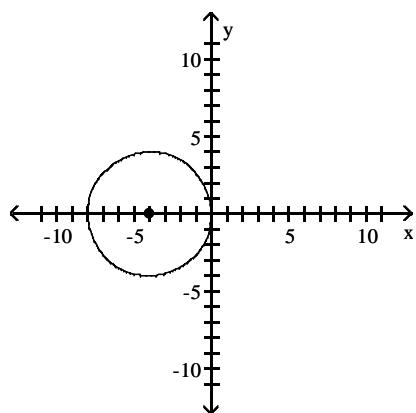

D)

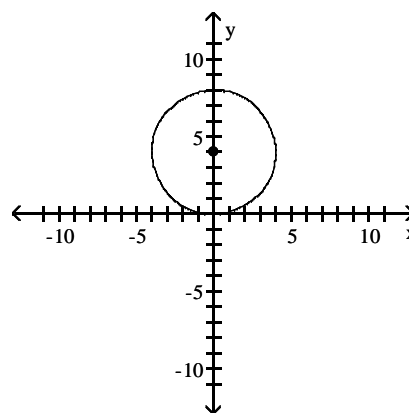

3)  $r = 3$ ;  $(h, k) = (3, 0)$

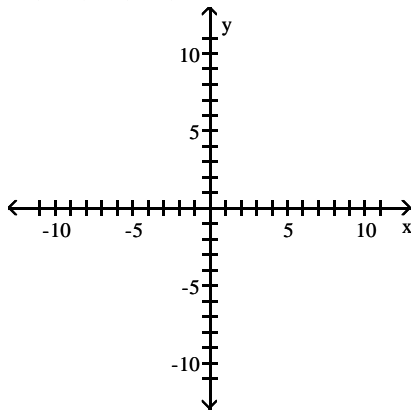

A)

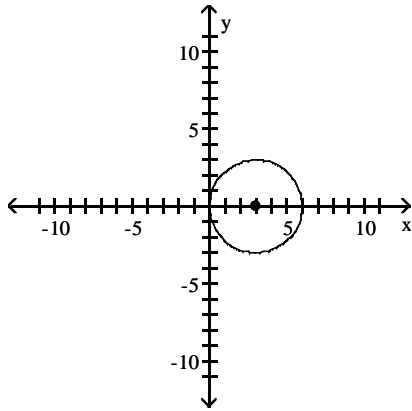

B)

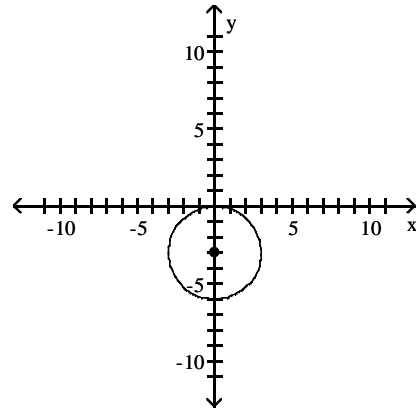

C)

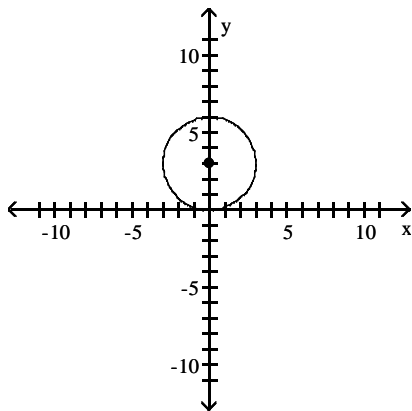

D)

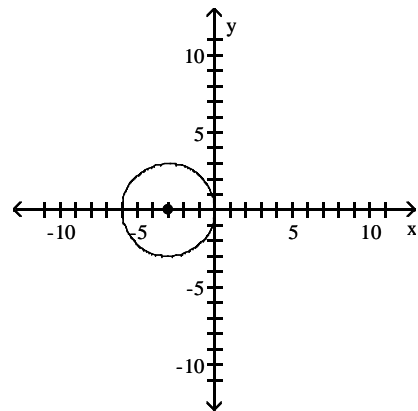

4)  $r = 3$ ;  $(h, k) = (5, -2)$

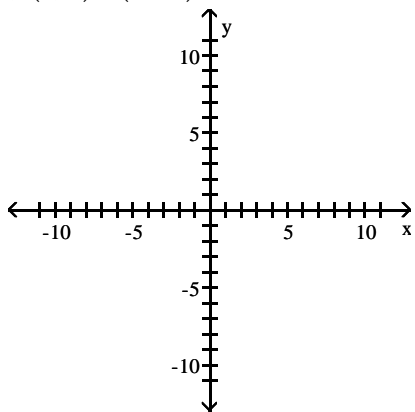

A)

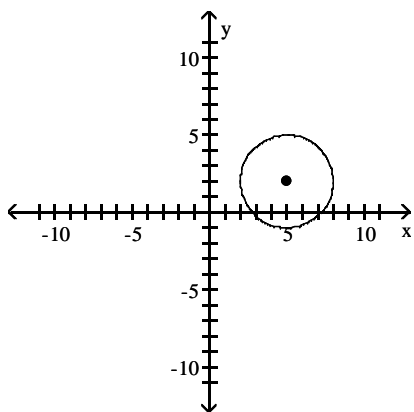

B)

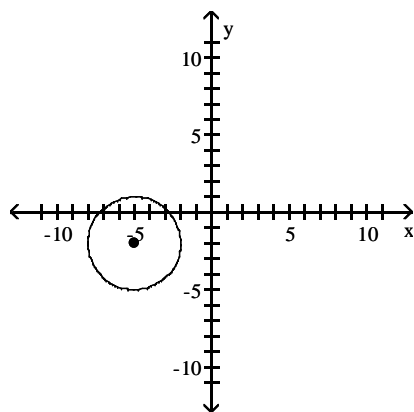

C)

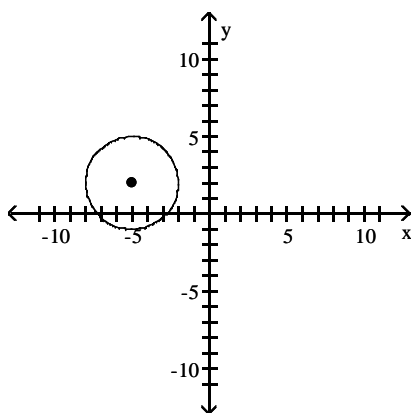

D)

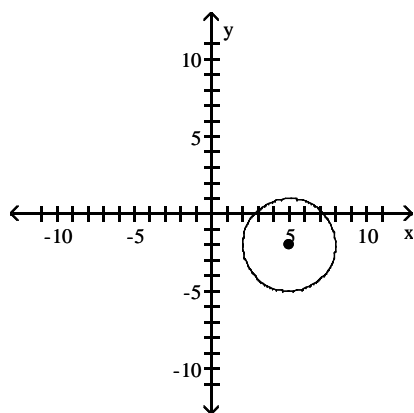

Graph the equation.

5)  $x^2 + y^2 = 16$

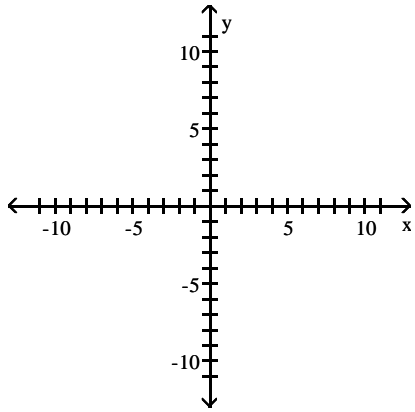

A)

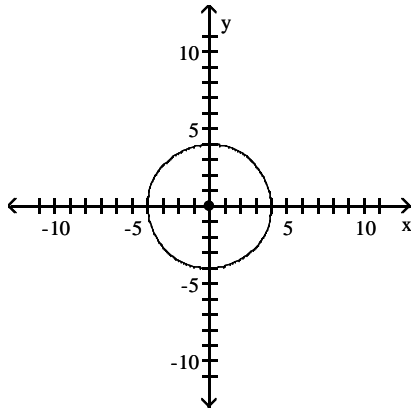

B)

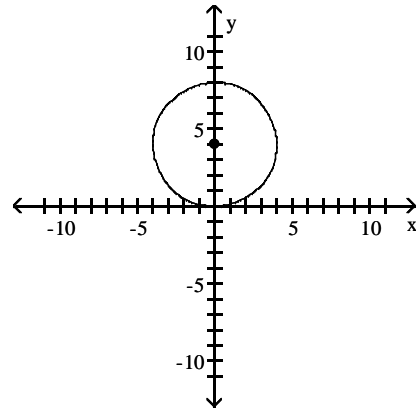

C)

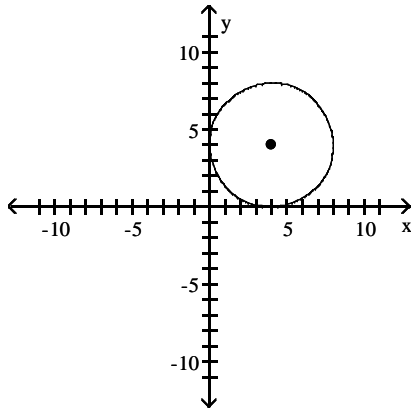

D)

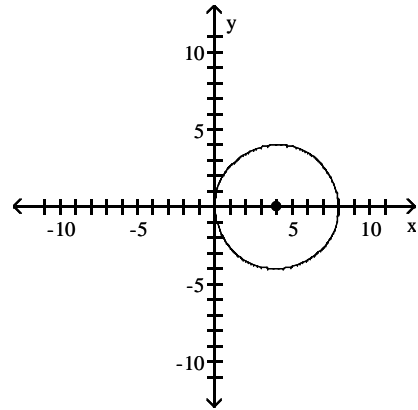

6)  $(x - 3)^2 + (y - 3)^2 = 4$

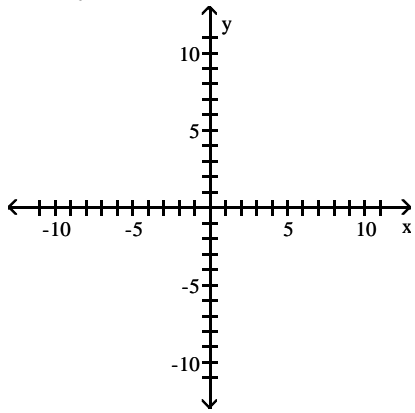

A)

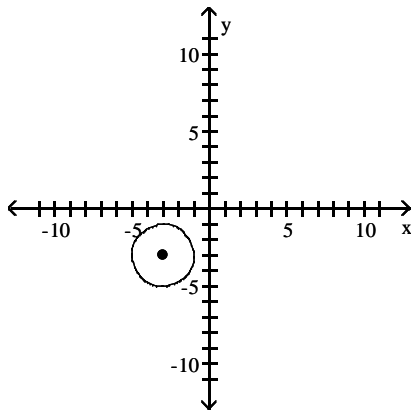

B)

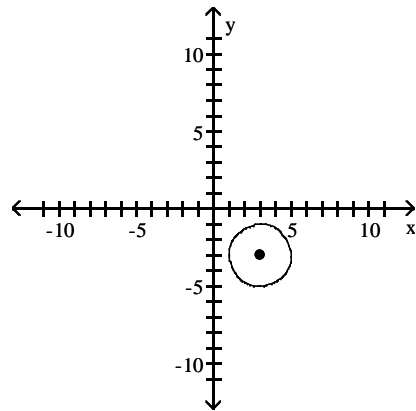

C)

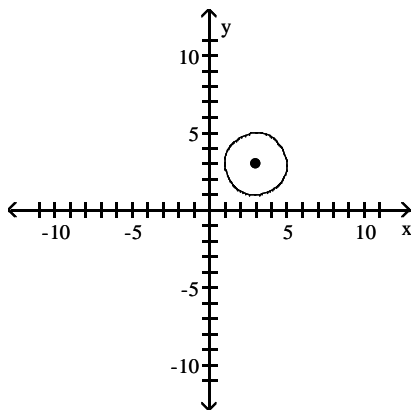

D)

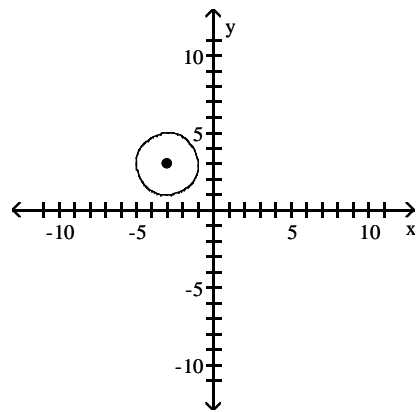

7)  $x^2 + (y - 1)^2 = 16$

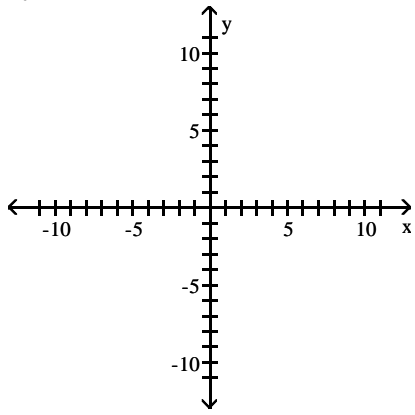

A)

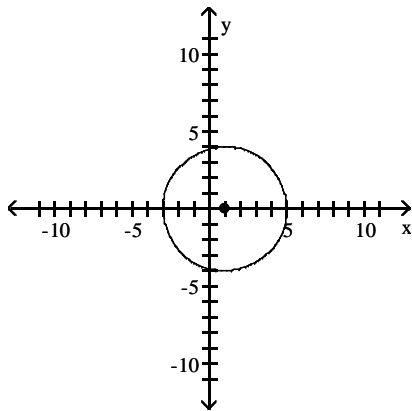

B)

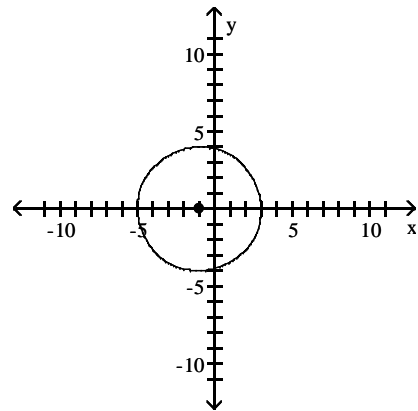

C)

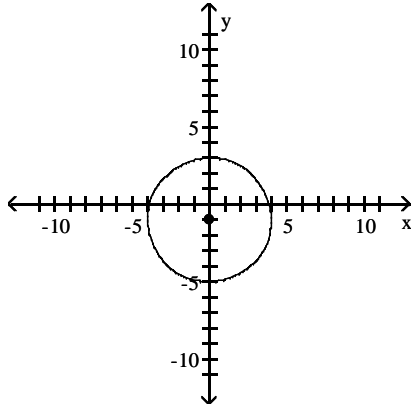

D)

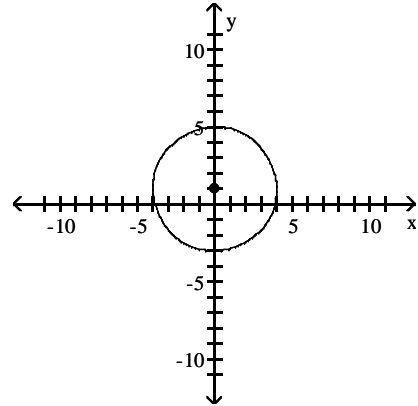



8)  $(x - 1)^2 + y^2 = 36$

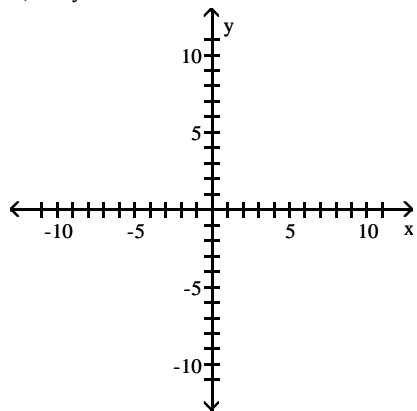

A)

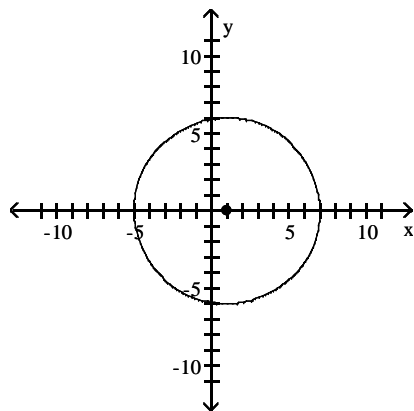

B)

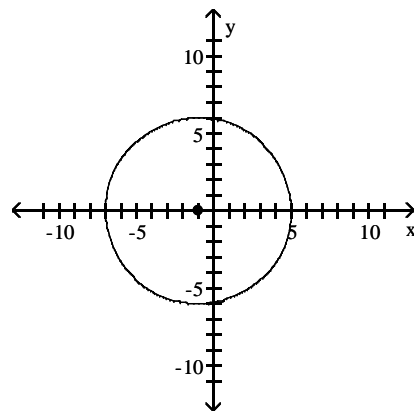

C)

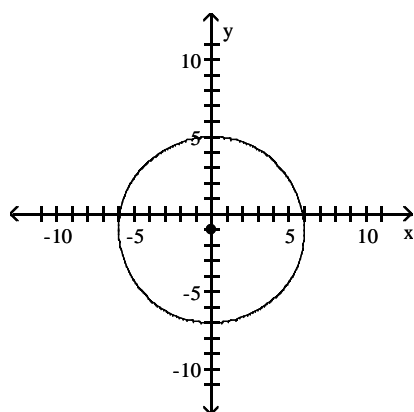

D)

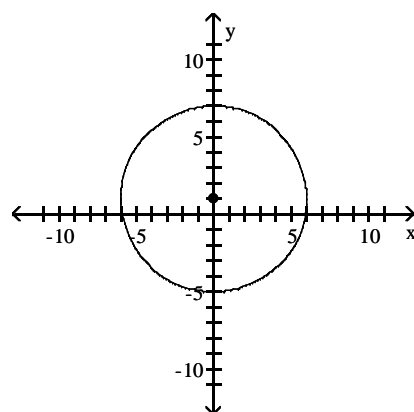

### 3 Work with the General Form of the Equation of a Circle

MULTIPLE CHOICE. Choose the one alternative that best completes the statement or answers the question.

Find the center  $(h, k)$  and radius  $r$  of the circle. Graph the circle.

1)  $x^2 + y^2 - 10x - 12y + 57 = 0$

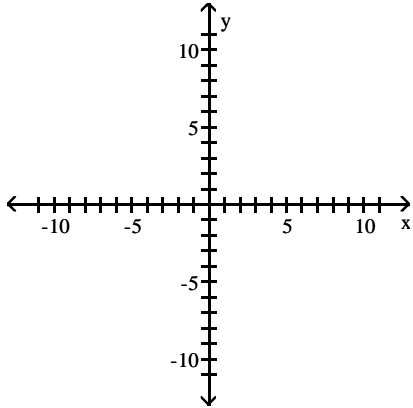

A)  $(h, k) = (-5, 6)$ ;  $r = 2$

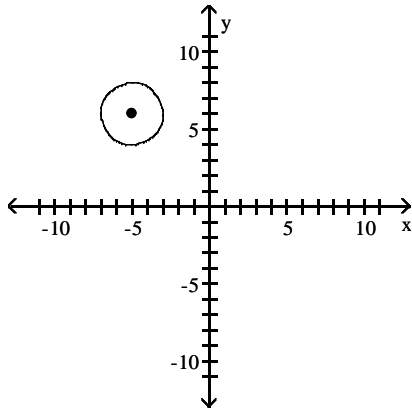

B)  $(h, k) = (5, -6)$ ;  $r = 2$

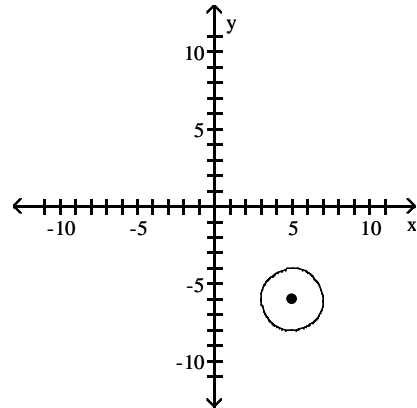

C)  $(h, k) = (5, 6)$ ;  $r = 2$

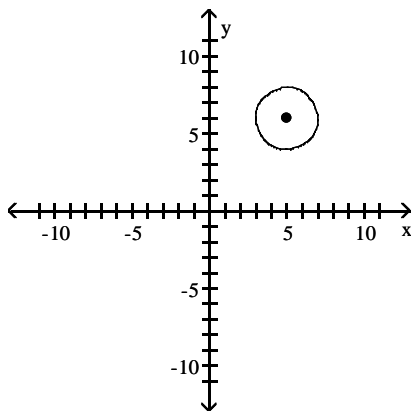

D)  $(h, k) = (-5, -6)$ ;  $r = 2$

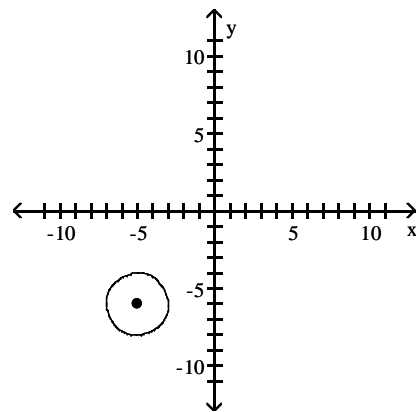

2)  $x^2 + y^2 + 10x + 6y + 30 = 0$

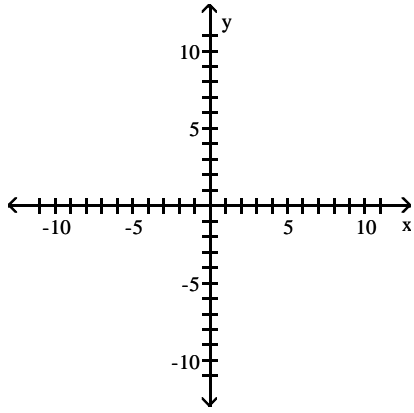

A)  $(h, k) = (5, 3); r = 2$

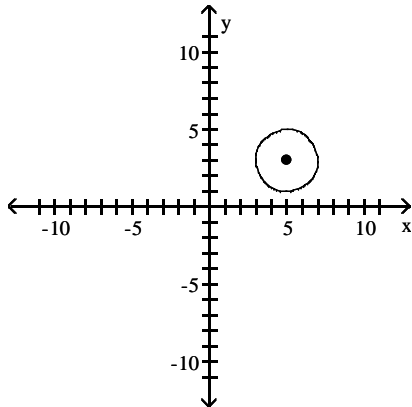

B)  $(h, k) = (-5, 3); r = 2$

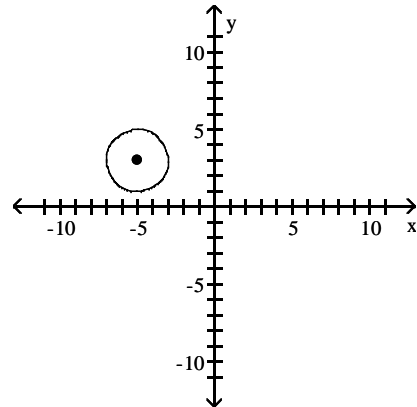

C)  $(h, k) = (-5, -3); r = 2$

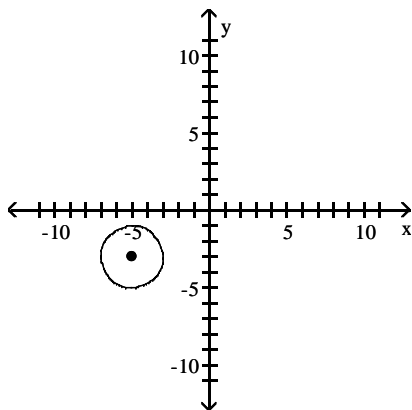

D)  $(h, k) = (5, -3); r = 2$

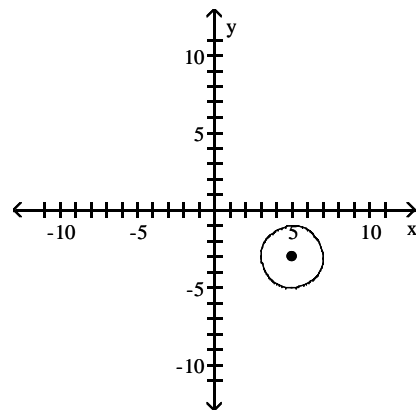

Find the center  $(h, k)$  and radius  $r$  of the circle with the given equation.

3)  $x^2 + 18x + 81 + (y + 3)^2 = 9$

A)  $(h, k) = (-3, -9); r = 3$

C)  $(h, k) = (3, 9); r = 9$

B)  $(h, k) = (-9, -3); r = 3$

D)  $(h, k) = (9, 3); r = 9$

4)  $x^2 - 10x + 25 + y^2 + 12y + 36 = 4$

A)  $(h, k) = (-6, 5); r = 2$

C)  $(h, k) = (-5, 6); r = 4$

B)  $(h, k) = (5, -6); r = 2$

D)  $(h, k) = (6, -5); r = 4$

5)  $x^2 + y^2 - 4x + 18y + 85 = 36$

A)  $(h, k) = (9, -2); r = 36$

C)  $(h, k) = (-9, 2); r = 6$

B)  $(h, k) = (2, -9); r = 6$

D)  $(h, k) = (-2, 9); r = 36$

6)  $x^2 + y^2 + 4x - 12y = -15$

A)  $(h, k) = (2, -6); r = 25$

C)  $(h, k) = (-2, 6); r = 5$

B)  $(h, k) = (6, -2); r = 5$

D)  $(h, k) = (-6, 2); r = 25$

7)  $4x^2 + 4y^2 - 12x + 16y - 5 = 0$

A)  $(h, k) = (-\frac{3}{2}, 2); r = \frac{3\sqrt{5}}{2}$

C)  $(h, k) = (\frac{3}{2}, -2); r = \frac{3\sqrt{5}}{2}$

B)  $(h, k) = (-\frac{3}{2}, 2); r = \frac{\sqrt{30}}{2}$

D)  $(h, k) = (\frac{3}{2}, -2); r = \frac{\sqrt{30}}{2}$

**Find the general form of the equation of the circle.**

8) Center at the point  $(-4, -3)$ ; containing the point  $(-3, 3)$

A)  $x^2 + y^2 - 6x + 6y - 12 = 0$

C)  $x^2 + y^2 + 6x - 6y - 17 = 0$

B)  $x^2 + y^2 + 6x + 8y - 17 = 0$

D)  $x^2 + y^2 + 8x + 6y - 12 = 0$

9) Center at the point  $(2, -3)$ ; containing the point  $(5, -3)$

A)  $x^2 + y^2 - 4x + 6y + 4 = 0$

C)  $x^2 + y^2 + 4x - 6y + 22 = 0$

B)  $x^2 + y^2 + 4x - 6y + 4 = 0$

D)  $x^2 + y^2 - 4x + 6y + 22 = 0$

10) Center at the point  $(5, 7)$ ; tangent to x-axis

A)  $x^2 + y^2 - 10x - 14y + 49 = 0$

C)  $x^2 + y^2 - 10x - 14y + 123 = 0$

B)  $x^2 + y^2 + 10x + 14y + 25 = 0$

D)  $x^2 + y^2 - 10x - 14y + 25 = 0$

**Solve the problem.**

11) If a circle of radius 1 is made to roll along the x-axis, what is the equation for the path of the center of the circle?

A)  $y = 0$

B)  $x = 1$

C)  $y = 2$

D)  $y = 1$

12) Earth is represented on a map of the solar system so that its surface is a circle with the equation

$x^2 + y^2 + 6x + 2y - 4215 = 0$ . A weather satellite circles 0.8 units above the Earth with the center of its circular orbit at the center of the Earth. Find the general form of the equation for the orbit of the satellite on this map.

A)  $x^2 + y^2 + 6x + 2y - 4319.64 = 0$

C)  $x^2 + y^2 + 6x + 2y - 54.36 = 0$

B)  $x^2 + y^2 - 6x - 2y - 4319.64 = 0$

D)  $x^2 + y^2 + 6x + 2y + 9.36 = 0$

13) Find an equation of the line containing the centers of the two circles

$x^2 + y^2 - 8x + 2y + 16 = 0$  and

$x^2 + y^2 + 2x + 6y + 6 = 0$

A)  $2x + 5y - 13 = 0$

B)  $2x - 5y - 13 = 0$

C)  $-2x - 5y - 13 = 0$

D)  $-4x - 3y - 13 = 0$

14) A wildlife researcher is monitoring a black bear that has a radio telemetry collar with a transmitting range of 20 miles. The researcher is in a research station with her receiver and tracking the bear's movements. If we put the origin of a coordinate system at the research station, what is the equation of all possible locations of the bear where the transmitter would be at its maximum range?

A)  $x^2 - y^2 = 20$

B)  $x^2 + y^2 = 20$

C)  $x^2 + y^2 = 400$

D)  $x^2 + y^2 = 40$

15) If a satellite is placed in a circular orbit of 330 kilometers above the Earth, what is the equation of the path of the satellite if the origin is placed at the center of the Earth (the diameter of the Earth is approximately 12,740 kilometers)?

A)  $x^2 + y^2 = 40,576,900$

C)  $x^2 + y^2 = 170,824,900$

B)  $x^2 + y^2 = 108,900$

D)  $x^2 + y^2 = 44,890,000$

- 16) A power outage affected all homes and businesses within a 11 mi radius of the power station. If the power station is located 12 mi north of the center of town, find an equation of the circle consisting of the furthest points from the station affected by the power outage.
- A)  $x^2 + (y - 12)^2 = 11$                       B)  $x^2 + (y + 12)^2 = 121$   
 C)  $x^2 + y^2 = 121$                                 D)  $x^2 + (y - 12)^2 = 121$
- 17) A power outage affected all homes and businesses within a 5 mi radius of the power station. If the power station is located 3 mi west and 3 mi north of the center of town, find an equation of the circle consisting of the furthest points from the station affected by the power outage.
- A)  $(x - 3)^2 + (y + 3)^2 = 25$                       B)  $(x - 3)^2 + (y - 3)^2 = 25$   
 C)  $(x + 3)^2 + (y + 3)^2 = 25$                       D)  $(x + 3)^2 + (y - 3)^2 = 25$
- 18) A Ferris wheel has a diameter of 360 feet and the bottom of the Ferris wheel is 9 feet above the ground. Find the equation of the wheel if the origin is placed on the ground directly below the center of the wheel, as illustrated.

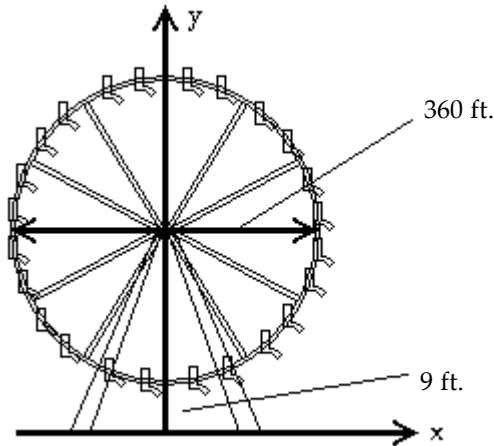

- A)  $x^2 + (y - 180)^2 = 32,400$                       B)  $x^2 + (y - 180)^2 = 129,600$   
 C)  $x^2 + (y - 189)^2 = 32,400$                       D)  $x^2 + y^2 = 32,400$

## 2.5 Variation

### 1 Construct a Model Using Direct Variation

MULTIPLE CHOICE. Choose the one alternative that best completes the statement or answers the question.

Write a general formula to describe the variation.

- 1)  $v$  varies directly with  $t$ ;  $v = 9$  when  $t = 20$

A)  $v = \frac{20}{9t}$

B)  $v = \frac{9}{20}t$

C)  $v = \frac{9}{20t}$

D)  $v = \frac{20}{9}t$

- 2)  $A$  varies directly with  $t^2$ ;  $A = 100$  when  $t = 5$

A)  $A = \frac{4}{t^2}$

B)  $A = \frac{20}{t^2}$

C)  $A = 4t^2$

D)  $A = 20t^2$

- 3)  $z$  varies directly with the sum of the squares of  $x$  and  $y$ ;  $z = 10$  when  $x = 6$  and  $y = 8$

A)  $z = \frac{1}{10}(x^2 + y^2)$

B)  $z = \frac{1}{20}(x^2 + y^2)$

C)  $z = \frac{1}{100}(x^2 + y^2)$

D)  $z^2 = x^2 + y^2$

If  $y$  varies directly as  $x$ , write a general formula to describe the variation.

4)  $y = 7$  when  $x = 42$

A)  $y = 6x$

B)  $y = x + 35$

C)  $y = \frac{1}{6}x$

D)  $y = \frac{1}{7}x$

5)  $y = 28$  when  $x = 16$

A)  $y = 4x$

B)  $y = \frac{7}{4}x$

C)  $y = \frac{4}{7}x$

D)  $y = x + 12$

6)  $y = 7$  when  $x = \frac{1}{6}$

A)  $y = \frac{1}{7}x$

B)  $y = 42x$

C)  $y = x + \frac{41}{6}$

D)  $y = \frac{1}{42}x$

7)  $y = 1.6$  when  $x = 0.4$

A)  $y = x + 1.2$

B)  $y = 0.25x$

C)  $y = 4x$

D)  $y = 0.4x$

8)  $y = 0.2$  when  $x = 1.6$

A)  $y = x - 1.4$

B)  $y = 0.2x$

C)  $y = 0.125x$

D)  $y = 8x$

Write a general formula to describe the variation.

9) The volume  $V$  of a right circular cone varies directly with the square of its base radius  $r$  and its height  $h$ . The constant of proportionality is  $\frac{1}{3}\pi$ .

A)  $V = \frac{1}{3}\pi r^2 h$

B)  $V = \frac{1}{3}\pi r^2 h^2$

C)  $V = \frac{1}{3}r^2 h$

D)  $V = \frac{1}{3}\pi r h$

10) The surface area  $S$  of a right circular cone varies directly as the radius  $r$  times the square root of the sum of the squares of the base radius  $r$  and the height  $h$ . The constant of proportionality is  $\pi$ .

A)  $S = \pi r \sqrt{r^2 h^2}$

B)  $S = \pi r \sqrt{r^2 + h^2}$

C)  $S = \pi \sqrt{r^2 + h^2}$

D)  $S = \pi r \sqrt{r^2 h}$

Solve the problem.

11) In simplified form, the period of vibration  $P$  for a pendulum varies directly as the square root of its length  $L$ . If  $P$  is 1.25 sec. when  $L$  is 25 in., what is the period when the length is 144 in.?

A) 48 sec

B) 576 sec

C) 36 sec

D) 3 sec

12) The amount of water used to take a shower is directly proportional to the amount of time that the shower is in use. A shower lasting 16 minutes requires 6.4 gallons of water. Find the amount of water used in a shower lasting 5 minutes.

A) 12.5 gal

B) 2 gal

C) 20.48 gal

D) 1.28 gal

13) If the resistance in an electrical circuit is held constant, the amount of current flowing through the circuit is directly proportional to the amount of voltage applied to the circuit. When 6 volts are applied to a circuit, 60 milliamperes (mA) of current flow through the circuit. Find the new current if the voltage is increased to 9 volts.

A) 90 mA

B) 100 mA

C) 54 mA

D) 81 mA

14) The amount of gas that a helicopter uses is directly proportional to the number of hours spent flying. The helicopter flies for 4 hours and uses 20 gallons of fuel. Find the number of gallons of fuel that the helicopter uses to fly for 6 hours.

A) 30 gal

B) 24 gal

C) 35 gal

D) 36 gal

15) The distance that an object falls when it is dropped is directly proportional to the square of the amount of time since it was dropped. An object falls 39.2 meters in 2 seconds. Find the distance the object falls in 4 seconds.

- A) 156.8 m                      B) 39.2 m                      C) 8 m                      D) 78.4 m

## 2 Construct a Model Using Inverse Variation

MULTIPLE CHOICE. Choose the one alternative that best completes the statement or answers the question.

**Write a general formula to describe the variation.**

1) A varies inversely with  $x^2$ ;  $A = 10$  when  $x = 2$

- A)  $A = \frac{5}{2}x^2$                       B)  $A = \frac{40}{x^2}$                       C)  $A = 20x^2$                       D)  $A = \frac{20}{x^2}$

**Write an equation that expresses the relationship. Use k as the constant of variation.**

2) g varies inversely as b.

- A)  $g = kb$                       B)  $g = \frac{b}{k}$                       C)  $kg = b$                       D)  $g = \frac{k}{b}$

3) c varies inversely as the square of v.

- A)  $c = \frac{\sqrt{v}}{k}$                       B)  $c = \frac{v^2}{k}$                       C)  $c = \frac{k}{v^2}$                       D)  $c = \frac{k}{\sqrt{v}}$

**If y varies inversely as x, write a general formula to describe the variation.**

4)  $y = 9$  when  $x = 5$

- A)  $y = \frac{9}{5}x$                       B)  $y = \frac{x}{45}$                       C)  $y = \frac{1}{45x}$                       D)  $y = \frac{45}{x}$

5)  $y = 15$  when  $x = 8$

- A)  $y = \frac{1}{120x}$                       B)  $y = \frac{120}{x}$                       C)  $y = \frac{x}{120}$                       D)  $y = \frac{15}{8}x$

6)  $y = 36$  when  $x = \frac{1}{4}$

- A)  $y = 144x$                       B)  $y = \frac{9}{x}$                       C)  $y = \frac{x}{9}$                       D)  $y = \frac{1}{9x}$

7)  $y = \frac{1}{8}$  when  $x = 32$

- A)  $y = \frac{1}{4x}$                       B)  $y = \frac{1}{256}x$                       C)  $y = \frac{4}{x}$                       D)  $y = \frac{x}{4}$

8)  $y = 0.2$  when  $x = 0.4$

- A)  $y = \frac{0.08}{x}$                       B)  $y = \frac{12.5}{x}$                       C)  $y = 12.5x$                       D)  $y = 0.5x$

**Solve the problem.**

9) x varies inversely as v, and  $x = 8$  when  $v = 4$ . Find x when  $v = 16$ .

- A)  $x = 2$                       B)  $x = 16$                       C)  $x = 4$                       D)  $x = 8$

10) x varies inversely as  $y^2$ , and  $x = 5$  when  $y = 12$ . Find x when  $y = 2$ .

- A)  $x = 150$                       B)  $x = 6$                       C)  $x = 180$                       D)  $x = 20$

- 11) When the temperature stays the same, the volume of a gas is inversely proportional to the pressure of the gas. If a balloon is filled with 72 cubic inches of a gas at a pressure of 14 pounds per square inch, find the new pressure of the gas if the volume is decreased to 12 cubic inches.
- A) 78 psi                      B) 70 psi                      C)  $\frac{6}{7}$  psi                      D) 84 psi
- 12) The amount of time it takes a swimmer to swim a race is inversely proportional to the average speed of the swimmer. A swimmer finishes a race in 30 seconds with an average speed of 5 feet per second. Find the average speed of the swimmer if it takes 25 seconds to finish the race.
- A) 8 ft/sec                      B) 6 ft/sec                      C) 5 ft/sec                      D) 7 ft/sec
- 13) If the force acting on an object stays the same, then the acceleration of the object is inversely proportional to its mass. If an object with a mass of 27 kilograms accelerates at a rate of 7 meters per second per second ( $\text{m/sec}^2$ ) by a force, find the rate of acceleration of an object with a mass of 9 kilograms that is pulled by the same force.
- A)  $\frac{7}{3}$   $\text{m/sec}^2$                       B) 18  $\text{m/sec}^2$                       C) 14  $\text{m/sec}^2$                       D) 21  $\text{m/sec}^2$
- 14) If the voltage,  $V$ , in an electric circuit is held constant, the current,  $I$ , is inversely proportional to the resistance,  $R$ . If the current is 350 milliamperes (mA) when the resistance is 5 ohms, find the current when the resistance is 35 ohms.
- A) 2443 mA                      B) 2450 mA                      C) 50 mA                      D) 250 mA
- 15) While traveling at a constant speed in a car, the centrifugal acceleration passengers feel while the car is turning is inversely proportional to the radius of the turn. If the passengers feel an acceleration of 6 feet per second per second ( $\text{ft/sec}^2$ ) when the radius of the turn is 100 feet, find the acceleration the passengers feel when the radius of the turn is 200 feet.
- A) 4  $\text{ft/sec}^2$                       B) 3  $\text{ft/sec}^2$                       C) 6  $\text{ft/sec}^2$                       D) 5  $\text{ft/sec}^2$

### 3 Construct a Model Using Joint Variation or Combined Variation

MULTIPLE CHOICE. Choose the one alternative that best completes the statement or answers the question.

Write a general formula to describe the variation.

- 1) The square of  $G$  varies directly with the cube of  $x$  and inversely with the square of  $y$ ;  $G = 4$  when  $x = 3$  and  $y = 6$

A)  $G^2 = 12 \frac{y^3}{x^2}$                       B)  $G^2 = \frac{4}{243} (x^3 + y^2)$                       C)  $G^2 = 8 \frac{x^3}{y^2}$                       D)  $G^2 = \frac{64}{3} \frac{x^3}{y^2}$

- 2)  $R$  varies directly with  $g$  and inversely with the square of  $h$ ;  $R = 3$  when  $g = 3$  and  $h = 5$ .

A)  $R = 5 \frac{h^2}{g}$                       B)  $R = 25 \frac{g}{h^2}$                       C)  $R = 25gh^2$                       D)  $R = 5 \frac{g}{h^2}$

- 3)  $z$  varies jointly as the cube root of  $x$  and the square of  $y$ ;  $z = 5$  when  $x = 8$  and  $y = 5$ .

A)  $z = \frac{1}{10} \sqrt[3]{xy^2}$                       B)  $z = 10 \sqrt[3]{xy^2}$                       C)  $z = \frac{2}{125} \frac{\sqrt[3]{x}}{y^2}$                       D)  $z = \frac{125}{2} \frac{\sqrt[3]{x}}{y^2}$

- 4) The centrifugal force  $F$  of an object speeding around a circular course varies directly as the product of the object's mass  $m$  and the square of its velocity  $v$  and inversely as the radius of the turn  $r$ .

A)  $F = \frac{km^2v}{r}$                       B)  $F = \frac{kmv}{r}$                       C)  $F = \frac{kmr}{v^2}$                       D)  $F = \frac{kmv^2}{r}$



- 5) The safety load  $\lambda$  of a beam with a rectangular cross section that is supported at each end varies directly as the product of the width  $W$  and the square of the depth  $D$  and inversely as the length  $L$  of the beam between the supports.

A)  $\lambda = \frac{kWD}{L}$

B)  $\lambda = \frac{kL}{WD^2}$

C)  $\lambda = \frac{kWD^2}{L}$

D)  $\lambda = \frac{k(W + D^2)}{L}$

- 6) The illumination  $I$  produced on a surface by a source of light varies directly as the candlepower  $c$  of the source and inversely as the square of the distance  $d$  between the source and the surface.

A)  $I = kcd^2$

B)  $I = \frac{kd^2}{c}$

C)  $I = \frac{kc^2}{d^2}$

D)  $I = \frac{kc}{d^2}$

**Solve the problem.**

- 7) The volume  $V$  of a given mass of gas varies directly as the temperature  $T$  and inversely as the pressure  $P$ . A measuring device is calibrated to give  $V = 240 \text{ in}^3$  when  $T = 240^\circ$  and  $P = 10 \text{ lb/in}^2$ . What is the volume on this device when the temperature is  $360^\circ$  and the pressure is  $25 \text{ lb/in}^2$ ?

A)  $V = 14.4 \text{ in}^3$

B)  $V = 144 \text{ in}^3$

C)  $V = 174 \text{ in}^3$

D)  $V = 114 \text{ in}^3$

- 8) The time in hours it takes a satellite to complete an orbit around the earth varies directly as the radius of the orbit (from the center of the earth) and inversely as the orbital velocity. If a satellite completes an orbit 790 miles above the earth in 16 hours at a velocity of 35,000 mph, how long would it take a satellite to complete an orbit if it is at 1100 miles above the earth at a velocity of 27,000 mph? (Use 3960 miles as the radius of the earth.)

A) 220.94 hr

B) 4.8 hr

C) 22.09 hr

D) 28.88 hr

- 9) The pressure of a gas varies jointly as the amount of the gas (measured in moles) and the temperature and inversely as the volume of the gas. If the pressure is 1302 kiloPascals (kPa) when the number of moles is 4, the temperature is  $310^\circ$  Kelvin, and the volume is 480 cc, find the pressure when the number of moles is 2, the temperature is  $340^\circ$  K, and the volume is 240 cc.

A) 1344 kPa

B) 2856 kPa

C) 3024 kPa

D) 1428 kPa

- 10) Body-mass index, or BMI, takes both weight and height into account when assessing whether an individual is underweight or overweight. BMI varies directly as one's weight, in pounds, and inversely as the square of one's height, in inches. In adults, normal values for the BMI are between 20 and 25. A person who weighs 162 pounds and is 71 inches tall has a BMI of 22.59. What is the BMI, to the nearest tenth, for a person who weighs 127 pounds and who is 66 inches tall?

A) 20.8

B) 19.8

C) 20.1

D) 20.5

- 11) The amount of paint needed to cover the walls of a room varies jointly as the perimeter of the room and the height of the wall. If a room with a perimeter of 60 feet and 8-foot walls requires 4.8 quarts of paint, find the amount of paint needed to cover the walls of a room with a perimeter of 65 feet and 10-foot walls.

A) 6.5 qt

B) 13 qt

C) 65 qt

D) 650 qt

- 12) The power that a resistor must dissipate is jointly proportional to the square of the current flowing through the resistor and the resistance of the resistor. If a resistor needs to dissipate 144 watts of power when 6 amperes of current is flowing through the resistor whose resistance is 4 ohms, find the power that a resistor needs to dissipate when 2 amperes of current are flowing through a resistor whose resistance is 3 ohms.

A) 12 watts

B) 18 watts

C) 36 watts

D) 6 watts

- 13) While traveling in a car, the centrifugal force a passenger experiences as the car drives in a circle varies jointly as the mass of the passenger and the square of the speed of the car. If a passenger experiences a force of 230.4 newtons (N) when the car is moving at a speed of 80 kilometers per hour and the passenger has a mass of 40 kilograms, find the force a passenger experiences when the car is moving at 80 kilometers per hour and the passenger has a mass of 60 kilograms.
- A) 384 N                      B) 307.2 N                      C) 345.6 N                      D) 448 N
- 14) The amount of simple interest earned on an investment over a fixed amount of time is jointly proportional to the principle invested and the interest rate. A principle investment of \$1200.00 with an interest rate of 3% earned \$108.00 in simple interest. Find the amount of simple interest earned if the principle is \$2100.00 and the interest rate is 8%.
- A) \$50,400.00                      B) \$504.00                      C) \$189.00                      D) \$288.00
- 15) The voltage across a resistor is jointly proportional to the resistance of the resistor and the current flowing through the resistor. If the voltage across a resistor is 18 volts (V) for a resistor whose resistance is 2 ohms and when the current flowing through the resistor is 9 amperes, find the voltage across a resistor whose resistance is 3 ohms and when the current flowing through the resistor is 7 amperes.
- A) 21 V                      B) 27 V                      C) 63 V                      D) 14 V

## Ch. 2 Graphs

### Answer Key

#### 2.1 The Distance and Midpoint Formulas

##### 1 Rectangular Coordinates

- 1) A
- 2) B
- 3) C
- 4) D
- 5) A
- 6) C
- 7) C
- 8) A
- 9) C
- 10) B
- 11) A
- 12) C
- 13) B
- 14) A
- 15) A
- 16) C
- 17) C
- 18) D

##### 2 Use the Distance Formula

- 1) A
- 2) A
- 3) A
- 4) B
- 5) D
- 6) D
- 7) B
- 8) C
- 9) D
- 10) B
- 11) D
- 12) D
- 13) A
- 14) A
- 15) B
- 16) B
- 17) D
- 18) A
- 19) D
- 20) D
- 21) D
- 22) D
- 23) D

##### 3 Use the Midpoint Formula

- 1) B
- 2) D
- 3) B
- 4) D
- 5) B
- 6) A

- 7) C
- 8) A
- 9) C
- 10) D
- 11) B

## 2.2 Graphs of Equations in Two Variables; Intercepts; Symmetry

### 1 Graph Equations by Plotting Points

- 1) B
- 2) A
- 3) A
- 4) A
- 5) A
- 6) A
- 7) A
- 8) D
- 9) B
- 10) D

### 2 Find Intercepts from a Graph

- 1) D
- 2) D
- 3) D
- 4) D
- 5) C
- 6) A
- 7) C
- 8) C

### 3 Find Intercepts from an Equation

- 1) B
- 2) C
- 3) A
- 4) A
- 5) D
- 6) B
- 7) C
- 8) D
- 9) A
- 10) B
- 11) D
- 12) C
- 13) B

### 4 Test an Equation for Symmetry with Respect to the $x$ -Axis, the $y$ -Axis, and the Origin

- 1) C
- 2) D
- 3) C
- 4) C
- 5) B
- 6) D
- 7) B
- 8) A
- 9) C
- 10) D
- 11) B
- 12) A
- 13) D

- 14) E
- 15) C
- 16) C
- 17) A
- 18) D
- 19) D
- 20) E
- 21) A
- 22) A
- 23) A
- 24) E
- 25) A
- 26) E
- 27) A
- 28) B

**5 Know How to Graph Key Equations**

- 1) B
- 2) B
- 3) A
- 4) A

**2.3 Lines**

**1 Calculate and Interpret the Slope of a Line**

- 1) A
- 2) C
- 3) D
- 4) D
- 5) D
- 6) A
- 7) A
- 8) B
- 9) D
- 10) B

**2 Graph Lines Given a Point and the Slope**

- 1) C
- 2) C
- 3) B
- 4) A
- 5) C
- 6) D
- 7) D
- 8) A
- 9) C

**3 Find the Equation of a Vertical Line**

- 1) A
- 2) D
- 3) B
- 4) D

**4 Use the Point-Slope Form of a Line; Identify Horizontal Lines**

- 1) A
- 2) A
- 3) C
- 4) C
- 5) C

**5 Find the Equation of a Line Given Two Points**

- 1) C
- 2) A
- 3) B
- 4) A
- 5) D
- 6) C
- 7) C
- 8) D
- 9) D
- 10) D
- 11) A
- 12) C
- 13) D
- 14) B
- 15) D
- 16) A

**6 Write the Equation of a Line in Slope-Intercept Form**

- 1) B
- 2) C
- 3) C
- 4) C
- 5) A
- 6) C
- 7) D
- 8) B
- 9) A
- 10) B
- 11) A
- 12) C
- 13) B

**7 Identify the Slope and y-Intercept of a Line from Its Equation**

- 1) C
- 2) A
- 3) D
- 4) A
- 5) B
- 6) D
- 7) A
- 8) C
- 9) A
- 10) C
- 11) B
- 12) B

**8 Graph Lines Written in General Form Using Intercepts**

- 1) A
- 2) A
- 3) C
- 4) D
- 5) D
- 6) B
- 7) D

**9 Find Equations of Parallel Lines**

- 1) D

- 2) B
- 3) A
- 4) D
- 5) A
- 6) C
- 7) B
- 8) A

**10 Find Equations of Perpendicular Lines**

- 1) B
- 2) A
- 3) C
- 4) B
- 5) D
- 6) C
- 7) B
- 8) D
- 9) B
- 10) B
- 11) B
- 12) B
- 13) A

**2.4 Circles**

**1 Write the Standard Form of the Equation of a Circle**

- 1) A
- 2) D
- 3) C
- 4) D
- 5) D
- 6) D
- 7) D
- 8) C
- 9) D
- 10) B
- 11) B
- 12) D
- 13) B
- 14) D
- 15) A
- 16) A
- 17) C

**2 Graph a Circle**

- 1) B
- 2) D
- 3) A
- 4) D
- 5) A
- 6) C
- 7) D
- 8) A

**3 Work with the General Form of the Equation of a Circle**

- 1) C
- 2) C
- 3) B
- 4) B

- 5) B
- 6) C
- 7) D
- 8) D
- 9) A
- 10) D
- 11) D
- 12) A
- 13) B
- 14) C
- 15) D
- 16) D
- 17) D
- 18) C

## 2.5 Variation

### 1 Construct a Model Using Direct Variation

- 1) B
- 2) C
- 3) A
- 4) C
- 5) B
- 6) B
- 7) C
- 8) C
- 9) A
- 10) B
- 11) D
- 12) B
- 13) A
- 14) A
- 15) A

### 2 Construct a Model Using Inverse Variation

- 1) B
- 2) D
- 3) C
- 4) D
- 5) B
- 6) B
- 7) C
- 8) A
- 9) A
- 10) C
- 11) D
- 12) B
- 13) D
- 14) C
- 15) B

### 3 Construct a Model Using Joint Variation or Combined Variation

- 1) D
- 2) B
- 3) A
- 4) D
- 5) C
- 6) D



- 7) B
- 8) C
- 9) D
- 10) D
- 11) A
- 12) A
- 13) C
- 14) B
- 15) A