

TEST BANK



Blitzer

COLLEGE ALGEBRA^{5e}



Ch. 2 Functions and Graphs

2.1 Basics of Functions and Their Graphs

1 Find the Domain and Range of a Relation

MULTIPLE CHOICE. Choose the one alternative that best completes the statement or answers the question.

Give the domain and range of the relation.

1) $\{(3, -9), (-6, -5), (1, 3), (1, 8)\}$

A) domain = $\{1, 3, -6\}$; range = $\{3, -9, -5, 8\}$

B) domain = $\{3, -9, -5, 8\}$; range = $\{1, 3, -6\}$

C) domain = $\{1, 3, -6, 11\}$; range = $\{3, -9, -5, 8\}$

D) domain = $\{1, 3, -6, -1\}$; range = $\{3, -9, -5, 8\}$

2) $\{(-4, 4), (12, 2), (7, -5), (7, -2)\}$

A) domain = $\{12, 7, -4\}$; range = $\{2, -5, 4, -2\}$

B) domain = $\{12, 7, -4, -7\}$; range = $\{2, -5, 4, -2\}$

C) domain = $\{12, 7, -4, 17\}$; range = $\{2, -5, 4, -2\}$

D) domain = $\{2, -5, 4, -2\}$; range = $\{12, 7, -4\}$

3) $\{(2, -1), (-5, -7), (-1, -2), (10, -4)\}$

A) domain = $\{-1, -5, 10, 2\}$; range = $\{-2, -7, -4, -1\}$

B) domain = $\{-2, -7, -4, -1\}$; range = $\{-1, -5, 10, 2\}$

C) domain = $\{-1, -5, 10, 2\}$; range = $\{-2, 1, -7, -4, -1\}$

D) domain = $\{-1, -5, 10, 2\}$; range = $\{-2, -2, -7, -4, -1\}$

4) $\{(4, -8), (4, 4), (9, 7), (1, -3), (7, 8)\}$

A) domain = $\{1, 4, 9, 7\}$; range = $\{-3, 4, 7, 8, -8\}$

B) domain = $\{1, -4, 4, 9, 7\}$; range = $\{-3, 4, 7, 8, -8\}$

C) domain = $\{1, 14, 4, 9, 7\}$; range = $\{-3, 4, 7, 8, -8\}$

D) domain = $\{-3, 4, 7, 8, -8\}$; range = $\{1, 1, 4, 9, 7\}$

5) $\{(1, -2), (-3, -1), (-3, 0), (-2, 1), (6, 3)\}$

A) domain: $\{1, -2, -3, 6\}$; range: $\{-2, -1, 0, 1, 3\}$

B) domain: $\{-2, -1, 1, 3\}$; range: $\{1, -2, -3, 6\}$

C) domain: $\{-2, -1, 0, 1, 3\}$; range: $\{1, -2, -3, 6\}$

D) domain: $\{1, -2, -3, 6\}$; range: $\{-2, -1, 1, 3\}$

6) $\{(-12, 6), (2, 2), (-8, -1), (5, 3), (-10, -4)\}$

A) domain = $\{2, 5, -10, -8, -12\}$; range = $\{2, 3, -4, -1, 6\}$

B) domain = $\{2, 3, -4, -1, 6\}$; range = $\{2, 5, -10, -8, -12\}$

C) domain = $\{2, 2, 5, 3, -10\}$; range = $\{-4, -8, -1, -12, 6\}$

D) domain = $\{-4, -8, -1, -12, 6\}$; range = $\{2, 2, 5, 3, -10\}$

7) $\{(-4, 18), (-3, 11), (0, 2), (3, 11), (5, 27)\}$

A) domain: $\{-4, -3, 0, 3, 5\}$; range: $\{18, 11, 2, 27\}$

B) domain: $\{-4, -3, 3, 5\}$; range: $\{18, 11, 2, 27\}$

C) domain: $\{18, 11, 2, 27\}$; range: $\{-4, -3, 0, 3, 5\}$

D) domain: $\{18, 11, 2, 27\}$; range: $\{-4, -3, 3, 5\}$

2 Determine Whether a Relation is a Function

MULTIPLE CHOICE. Choose the one alternative that best completes the statement or answers the question.

Determine whether the relation is a function.

- 1) $\{(-2, -7), (3, -5), (6, -4), (9, -6), (10, -1)\}$
A) Function
B) Not a function
- 2) $\{(-5, -4), (-2, 9), (-1, -2), (-1, 7)\}$
A) Not a function
B) Function
- 3) $\{(-7, -1), (-7, 2), (-1, 8), (3, 3), (10, -7)\}$
A) Not a function
B) Function
- 4) $\{(1, -3), (1, 1), (6, -8), (9, -3), (11, -3)\}$
A) Not a function
B) Function
- 5) $\{(-6, -9), (-2, 1), (1, -1), (7, -7)\}$
A) Function
B) Not a function
- 6) $\{(-9, 1), (-9, 9), (1, -5), (6, -6), (9, -5)\}$
A) Not a function
B) Function
- 7) $\{(-6, 6), (-4, 1), (1, 9), (3, 2)\}$
A) Function
B) Not a function
- 8) $\{(-6, 1), (-2, 1), (2, 6), (2, -2)\}$
A) Not a function
B) Function
- 9) $\{(-5, -2), (-1, 2), (3, 8), (7, -1)\}$
A) Function
B) Not a function
- 10) $\{(-3, -3), (3, -4), (6, 2), (9, -4), (10, -4)\}$
A) Function
B) Not a function

3 Determine Whether an Equation Represents a Function

MULTIPLE CHOICE. Choose the one alternative that best completes the statement or answers the question.

Determine whether the equation defines y as a function of x .

- 1) $x + y = 9$
A) y is a function of x
B) y is not a function of x
- 2) $2x + 4y = 5$
A) y is a function of x
B) y is not a function of x

3) $x^2 + y = 81$

A) y is a function of x

B) y is not a function of x

4) $x + y^2 = 49$

A) y is a function of x

B) y is not a function of x

5) $x^2 + y^2 = 1$

A) y is a function of x

B) y is not a function of x

6) $y^2 = 7x$

A) y is a function of x

B) y is not a function of x

7) $x = y^2$

A) y is a function of x

B) y is not a function of x

8) $y = x^2$

A) y is a function of x

B) y is not a function of x

9) $y = -\sqrt{x+7}$

A) y is a function of x

B) y is not a function of x

10) $y = \sqrt{4x+3}$

A) y is a function of x

B) y is not a function of x

11) $x + y^3 = 64$

A) y is a function of x

B) y is not a function of x

12) $xy - 5y = 1$

A) y is a function of x

B) y is not a function of x

13) $|x| - y = 3$

A) y is a function of x

B) y is not a function of x

4 Evaluate a Function

MULTIPLE CHOICE. Choose the one alternative that best completes the statement or answers the question.

Evaluate the function at the given value of the independent variable and simplify.

1) $f(x) = -3x - 8$; $f(-2)$

A) -2

B) 22

C) 14

D) -11

2) $f(x) = x^2 - 1$; $f(x - 2)$

A) $x^2 - 4x + 3$

B) $x^2 + 4$

C) $x^2 - 4x + 4$

D) $x^2 - 3$

- 3) $f(x) = 4x^2 + 5x - 6$; $f(x - 1)$
 A) $4x^2 - 3x - 7$ B) $-3x^2 + 4x - 7$ C) $4x^2 - 3x + 3$ D) $4x^2 - 19x + 3$
- 4) $g(x) = 3x + 2$; $g(x - 1)$
 A) $3x - 1$ B) $3x + 2$ C) $3x + 1$ D) $\frac{1}{3}x + 2$
- 5) $h(x) = |x - 2|$; $h(13)$
 A) 11 B) -15 C) 15 D) -11
- 6) $f(x) = \sqrt{x + 11}$; $f(-2)$
 A) 3 B) -3 C) 1.73 D) not a real number
- 7) $f(x) = \frac{x^2 - 6}{x^3 - 7x}$; $f(5)$
 A) $\frac{19}{90}$ B) $\frac{19}{125}$ C) $\frac{19}{118}$ D) $\frac{5}{18}$
- 8) $f(x) = \frac{x^3 + 7}{x^2 - 2}$; $f(-2)$
 A) $-\frac{1}{2}$ B) $-\frac{1}{4}$ C) -4 D) $\frac{11}{2}$

Solve the problem.

- 9) The function $P(x) = 0.9x - 94$ models the relationship between the number of pretzels x that a certain vendor sells and the profit the vendor makes. Find $P(700)$, the profit the vendor makes from selling 700 pretzels.
 A) \$536 B) \$630 C) \$724 D) \$606
- 10) The total cost in dollars for a certain company to produce x empty jars to be used by a jelly producer is given by the function $C(x) = 0.4x + 18,000$. Find $C(80,000)$, the cost of producing 80,000 jars.
 A) \$50,000 B) \$32,000 C) \$18.40 D) \$80,018

5 Graph Functions by Plotting Points

MULTIPLE CHOICE. Choose the one alternative that best completes the statement or answers the question.

Graph the given functions on the same rectangular coordinate system. Describe how the graph of g is related to the graph of f .

1) $f(x) = x$, $g(x) = x + 4$

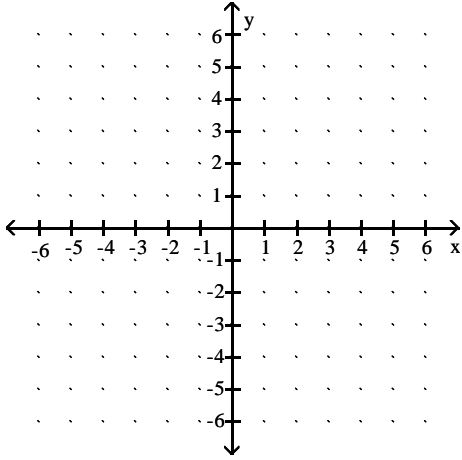

A) g shifts the graph of f vertically up 4 units

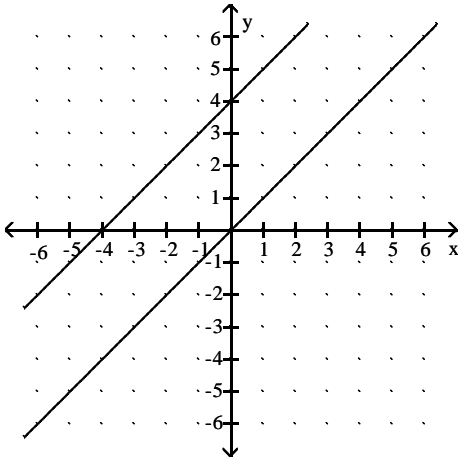

B) g shifts the graph of f vertically down 4 units

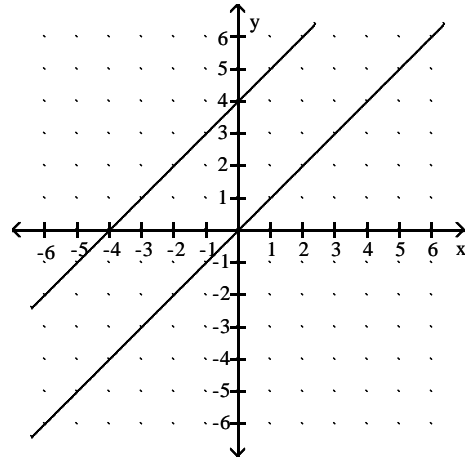

C) g shifts the graph of f vertically down 4 units

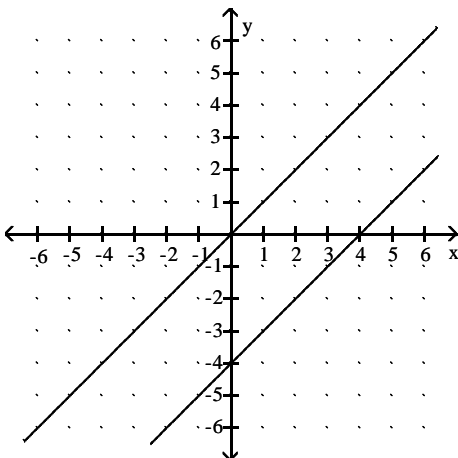

D) g shifts the graph of f vertically up 4 units

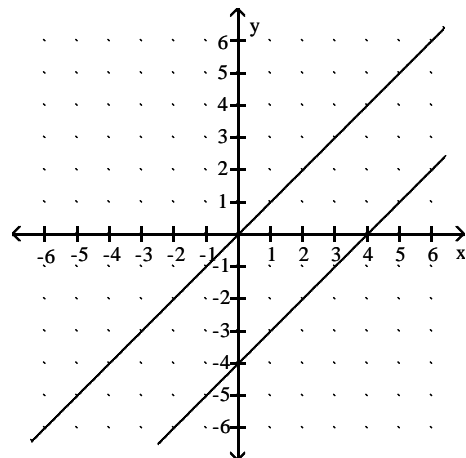

2) $f(x) = x, g(x) = x - 3$

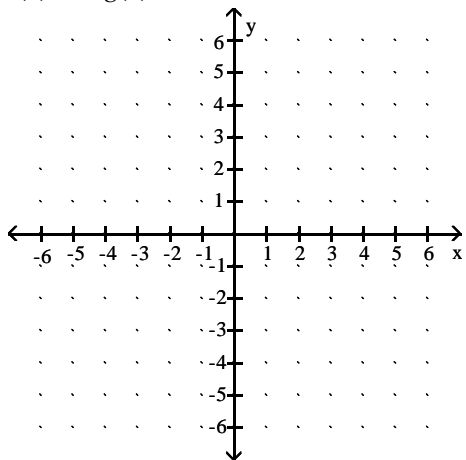

A) g shifts the graph of f vertically down 3 units

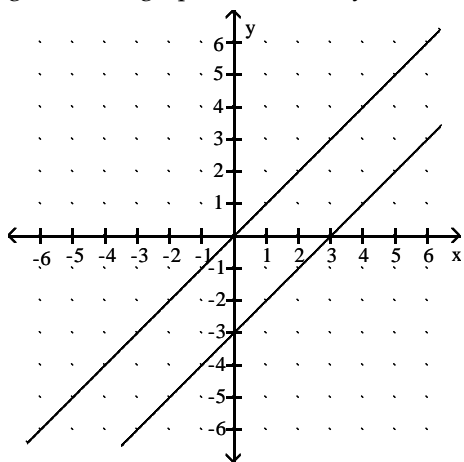

B) g shifts the graph of f vertically down 3 units

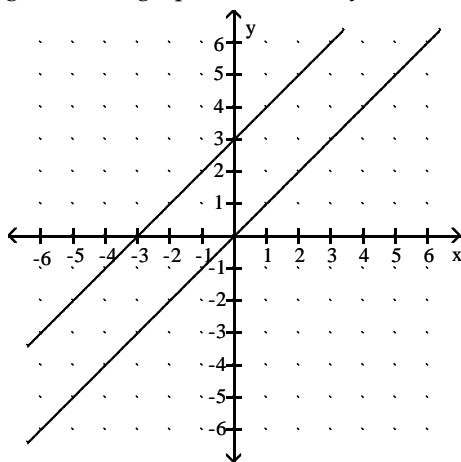

C) g shifts the graph of f vertically up 3 units

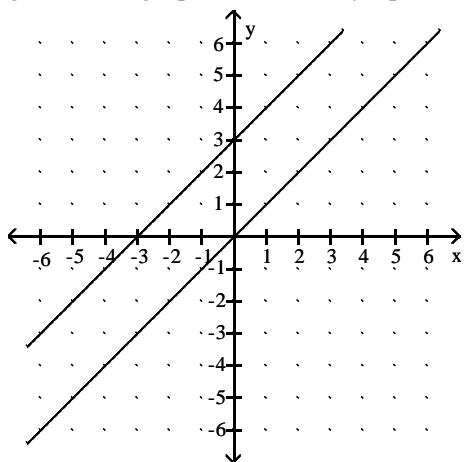

D) g shifts the graph of f vertically up 3 units

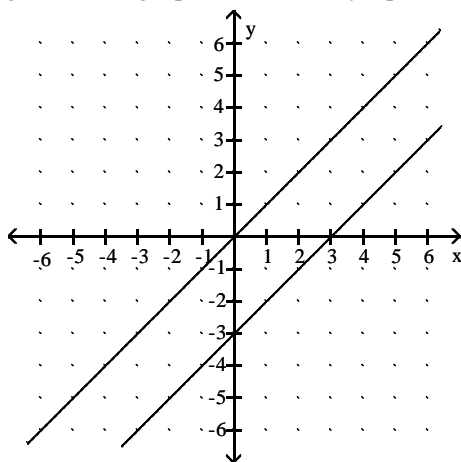

3) $f(x) = -2x$, $g(x) = -2x - 3$

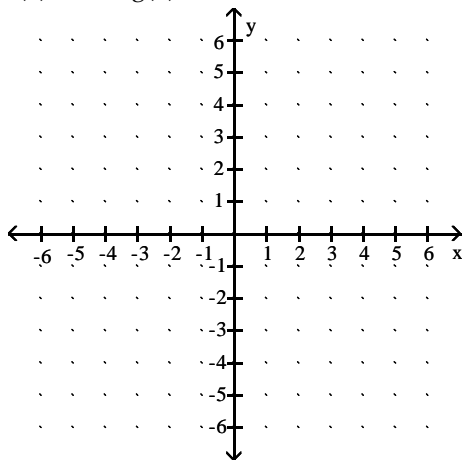

A) g shifts the graph of f vertically down 3 units

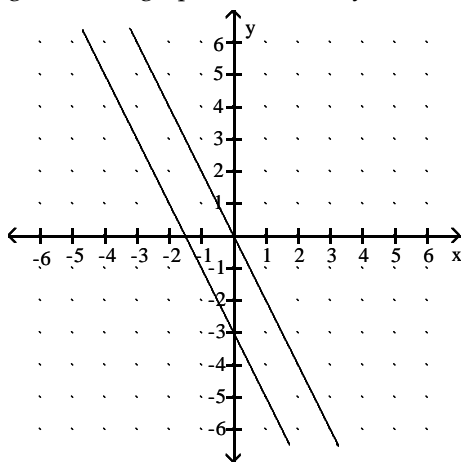

B) g shifts the graph of f vertically down 3 units

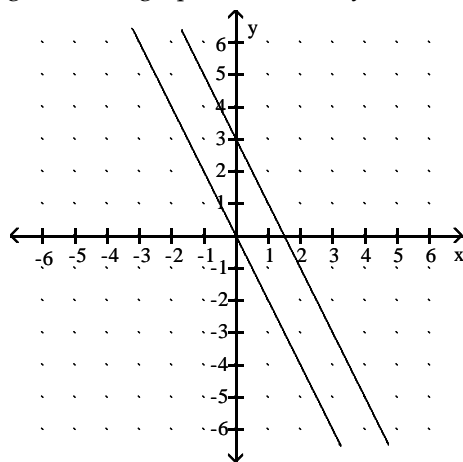

C) g shifts the graph of f vertically up 3 units

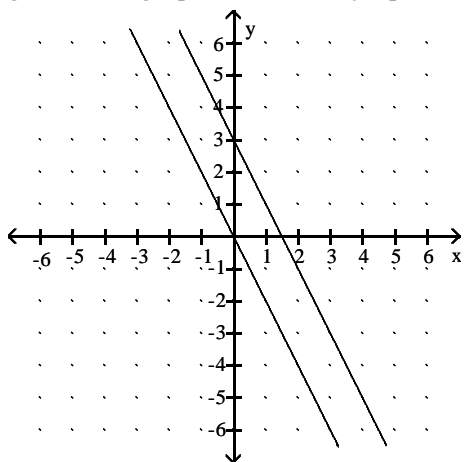

D) g shifts the graph of f vertically up 3 units

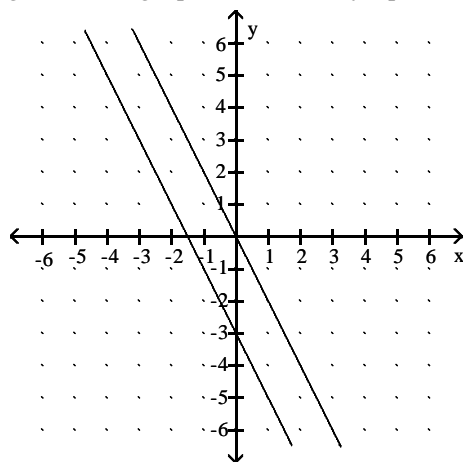

4) $f(x) = x^2$, $g(x) = x^2 + 2$

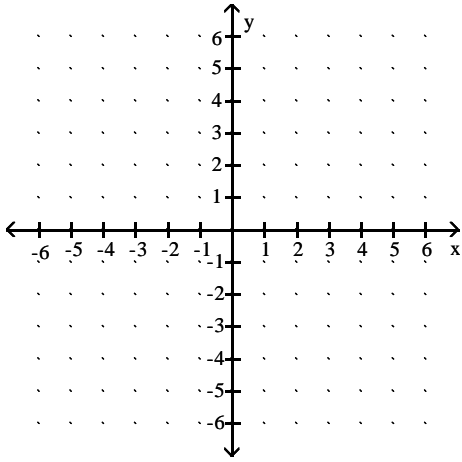

A) g shifts the graph of f vertically up 2 units

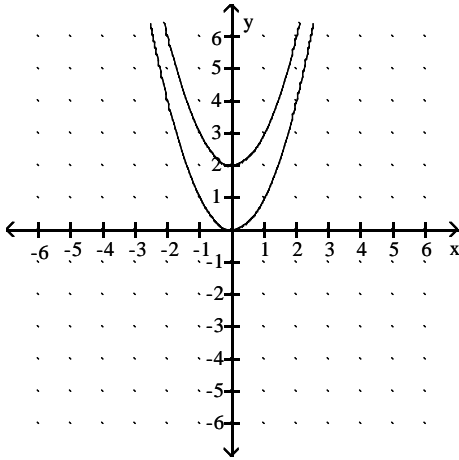

B) g shifts the graph of f vertically down 2 units

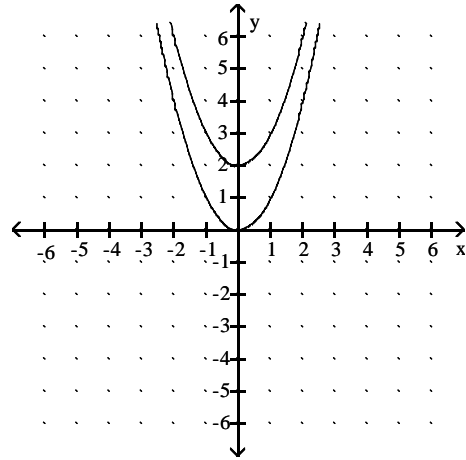

C) g shifts the graph of f vertically down 2 units

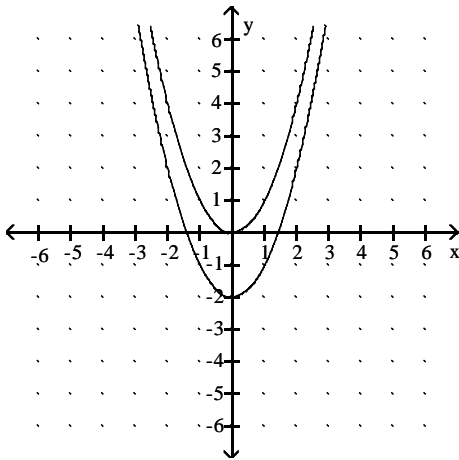

D) g shifts the graph of f vertically up 2 units

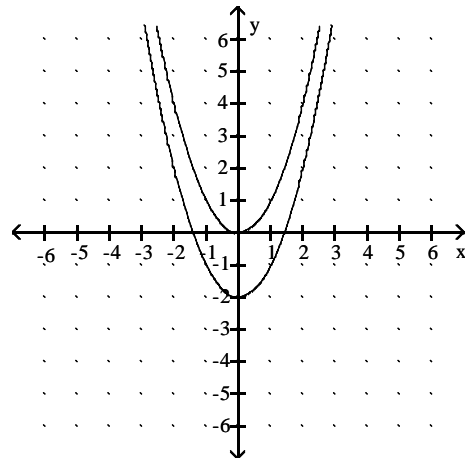

5) $f(x) = 2x^2$, $g(x) = 2x^2 - 1$

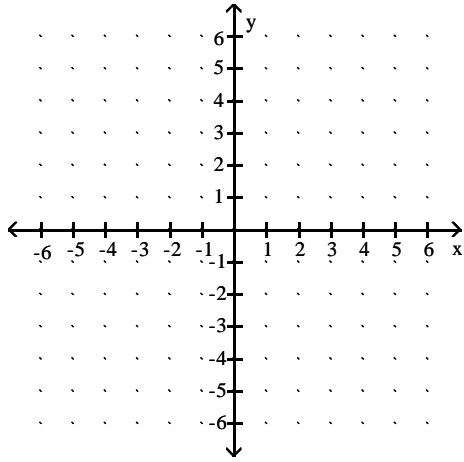

A) g shifts the graph of f vertically down 1 unit

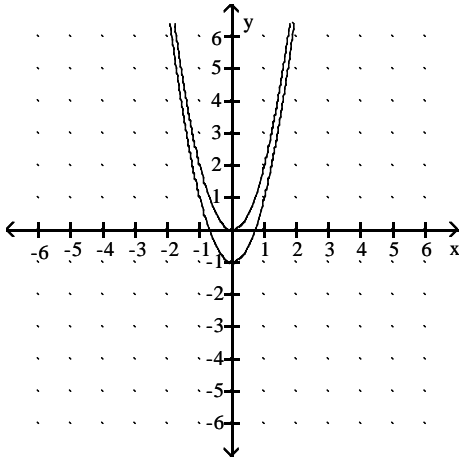

B) g shifts the graph of f vertically down 1 unit

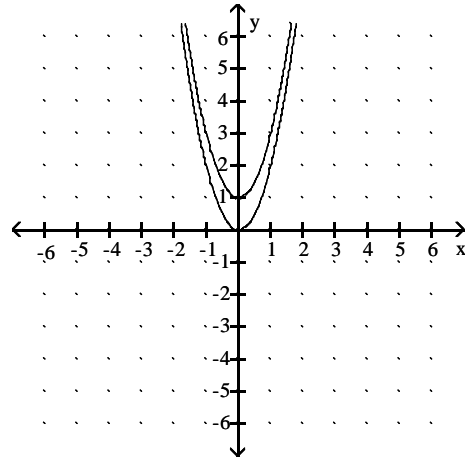

C) g shifts the graph of f vertically up 1 unit

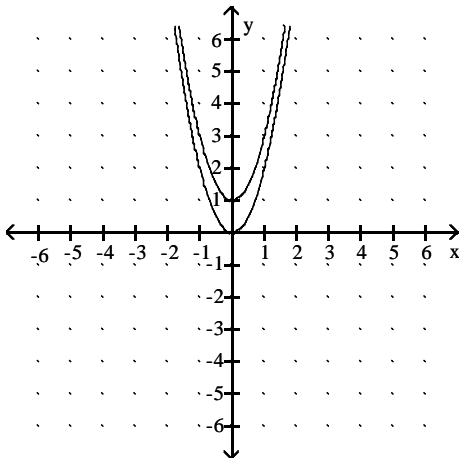

D) g shifts the graph of f vertically up 1 unit

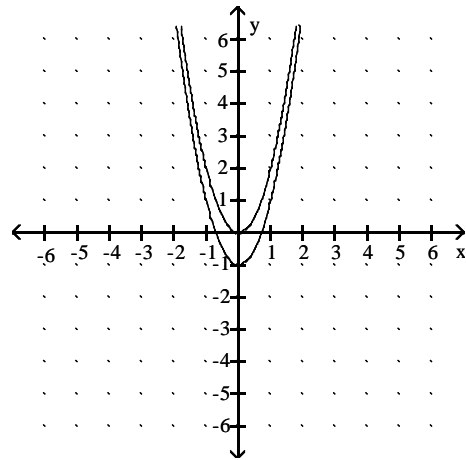

6) $f(x) = |x|$, $g(x) = |x| + 3$

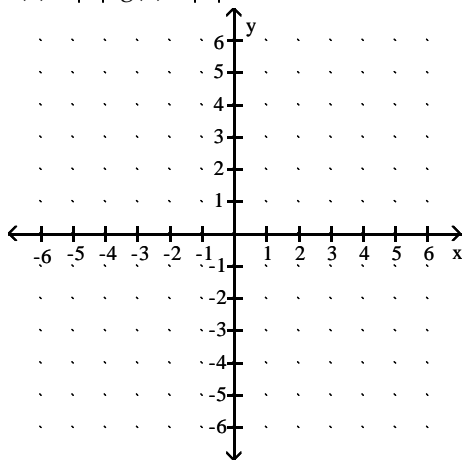

A) g shifts the graph of f vertically up 3 units

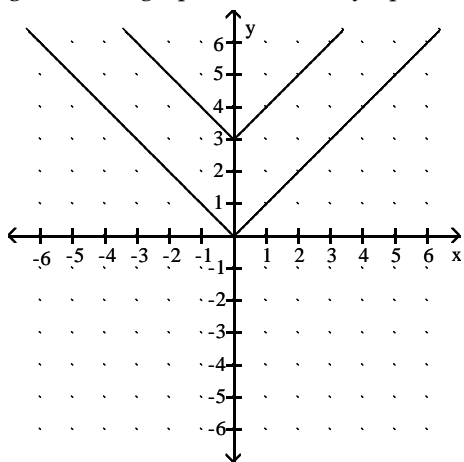

B) g shifts the graph of f vertically down 3 units

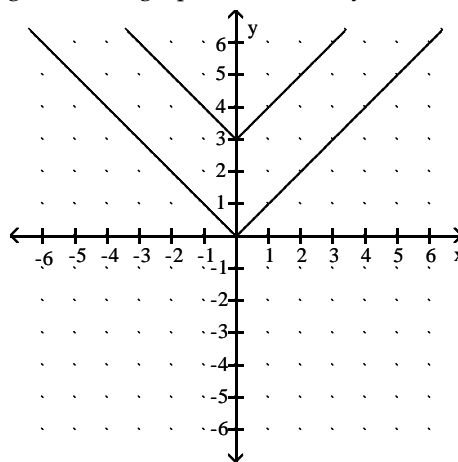

C) g shifts the graph of f vertically down 3 units

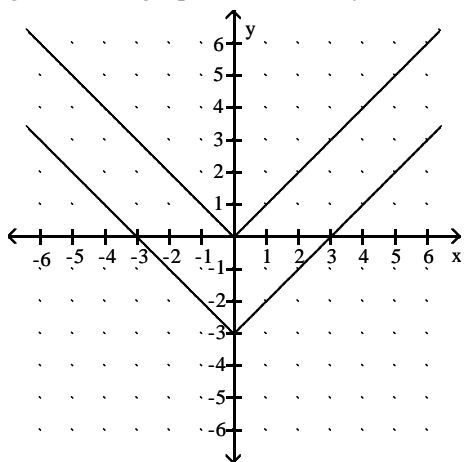

D) g shifts the graph of f vertically up 3 units

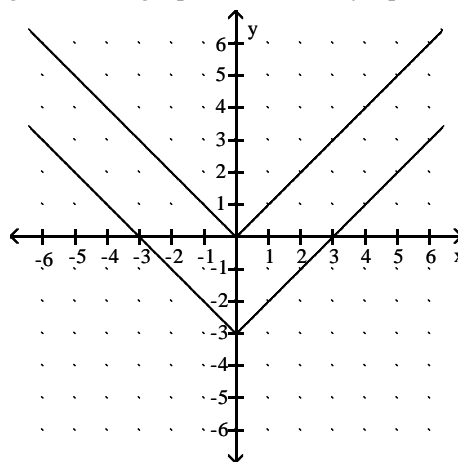

7) $f(x) = |x|$, $g(x) = |x| - 2$

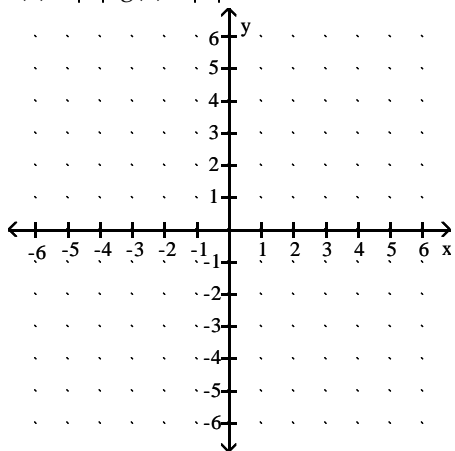

A) g shifts the graph of f vertically down 2 units

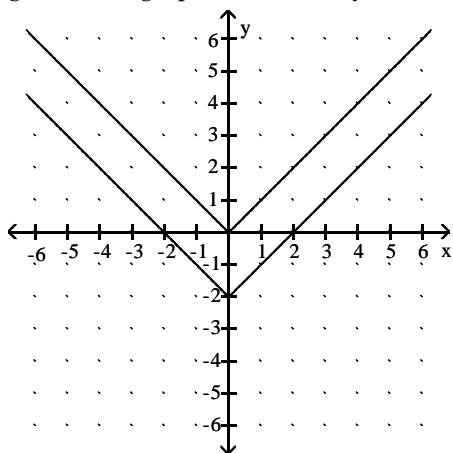

B) g shifts the graph of f vertically up 2 units

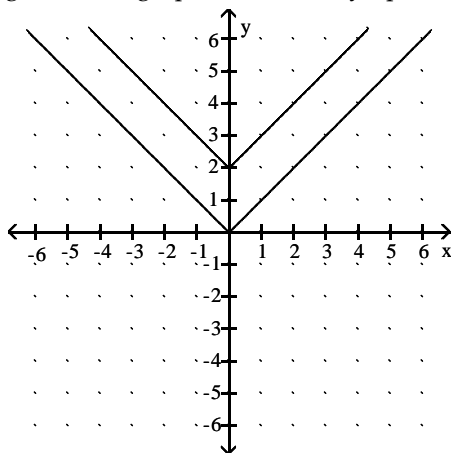

C) g shifts the graph of f vertically down 2 units

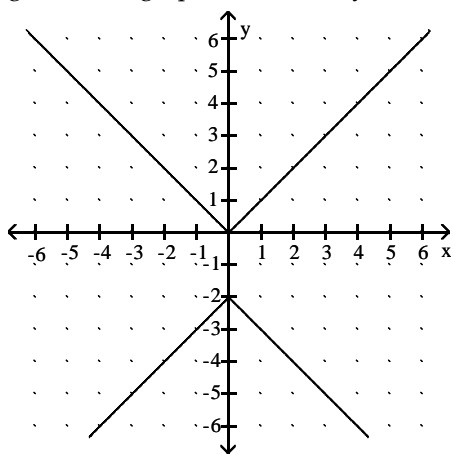

D) g shifts the graph of f vertically up 2 units

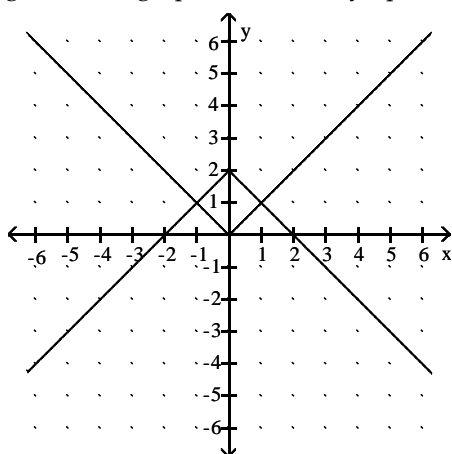

8) $f(x) = x^3$, $g(x) = x^3 + 3$

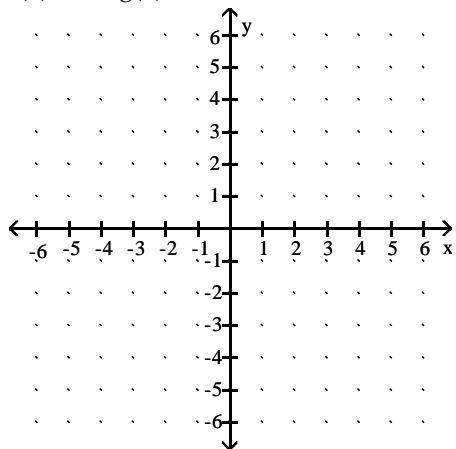

A) g shifts the graph of f vertically up 3 units

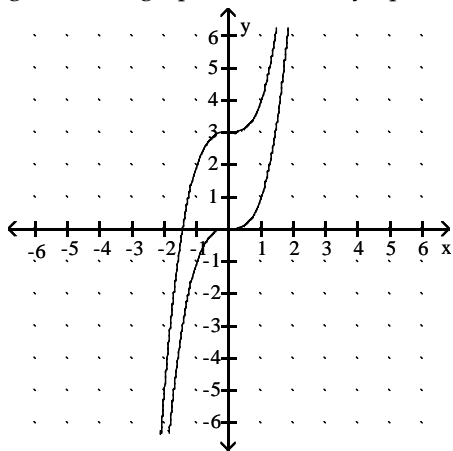

B) g shifts the graph of f vertically down 3 units

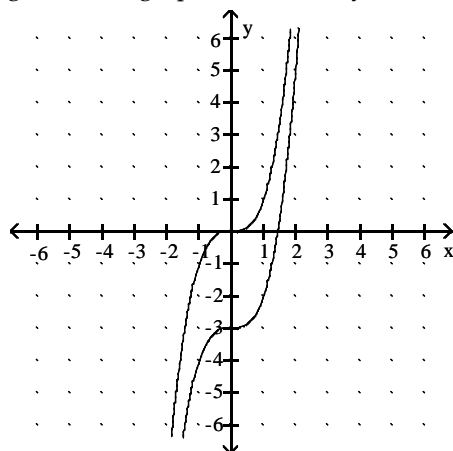

C) g shifts the graph of f vertically up 3 units

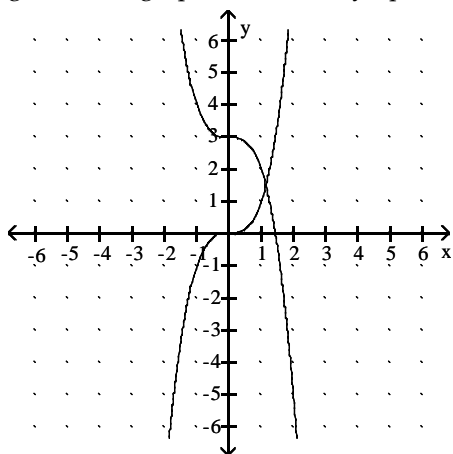

D) g shifts the graph of f vertically down 3 units

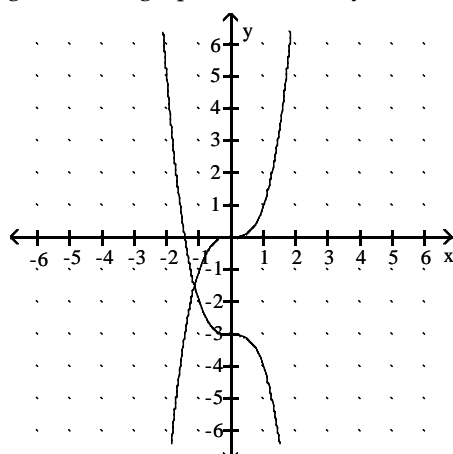

9) $f(x) = \sqrt{x}$, $g(x) = \sqrt{x} + 4$

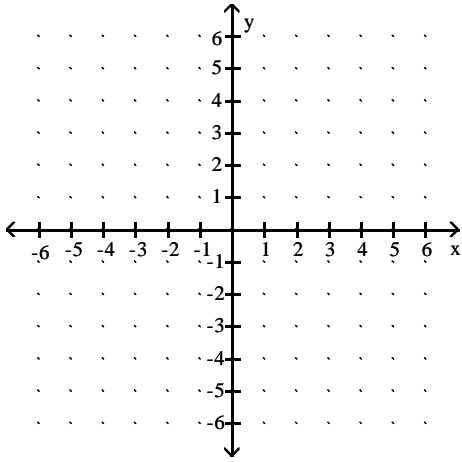

A) g shifts the graph of f vertically up 4 units

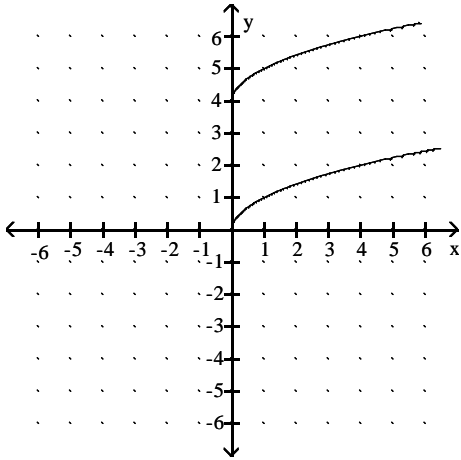

B) g shifts the graph of f vertically down 4 units

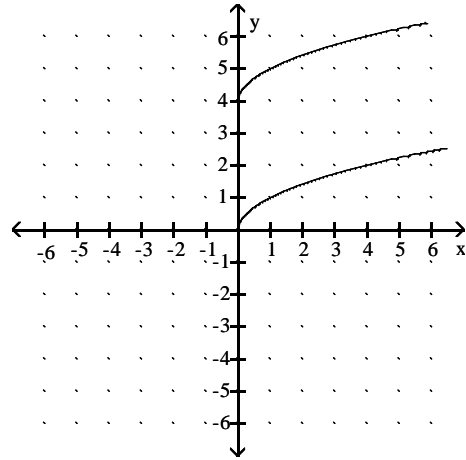

C) g shifts the graph of f vertically down 4 units

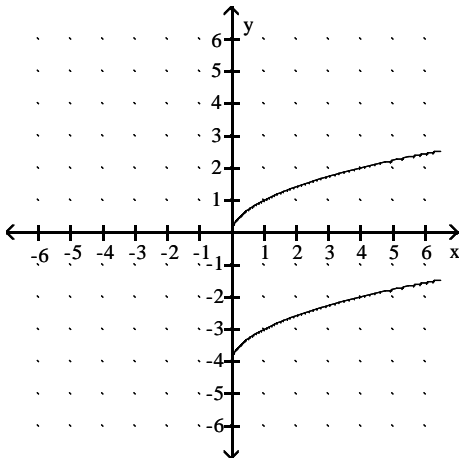

D) g shifts the graph of f vertically up 4 units

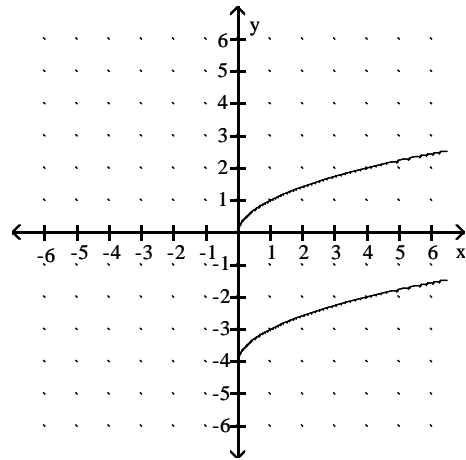

10) $f(x) = \sqrt{x}$, $g(x) = \sqrt{x} - 4$

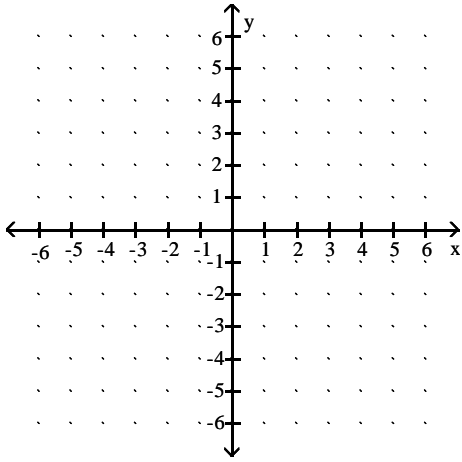

A) g shifts the graph of f vertically down 4 units

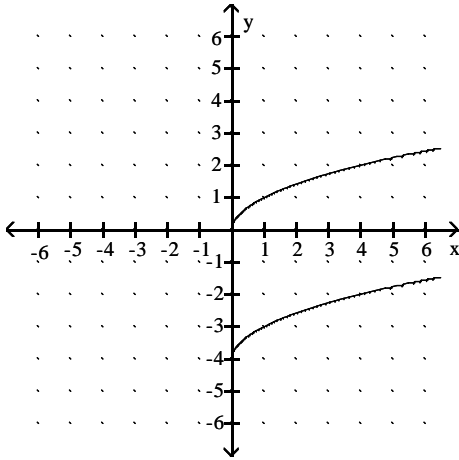

B) g shifts the graph of f vertically up 4 units

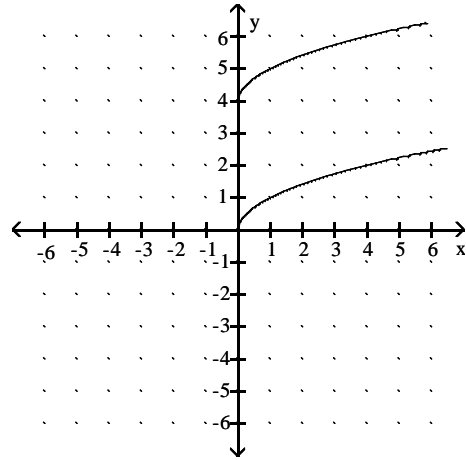

C) g shifts the graph of f vertically down 4 units

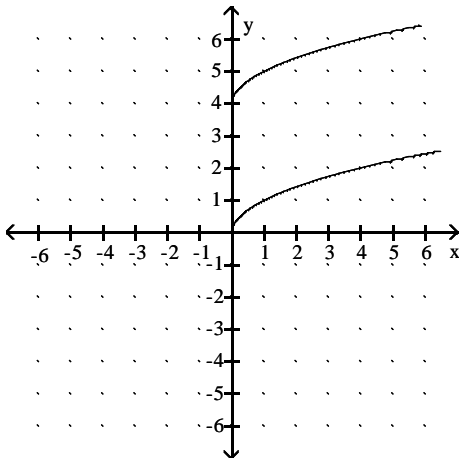

D) g shifts the graph of f vertically up 4 units

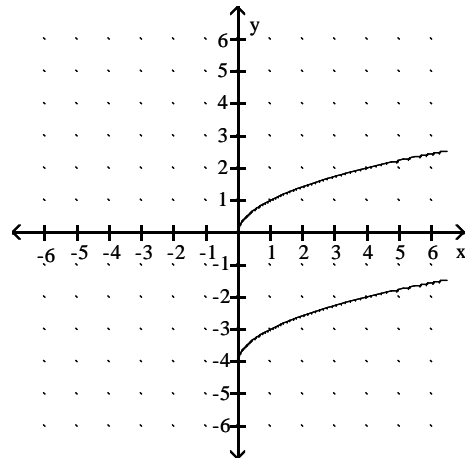

11) $f(x) = \sqrt{x}$, $g(x) = \sqrt{x+3}$

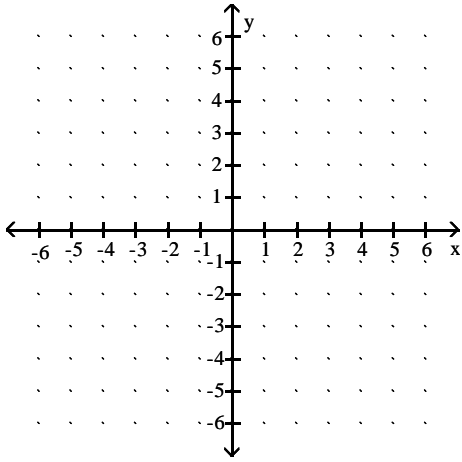

A) g shifts the graph of f 3 units to the left

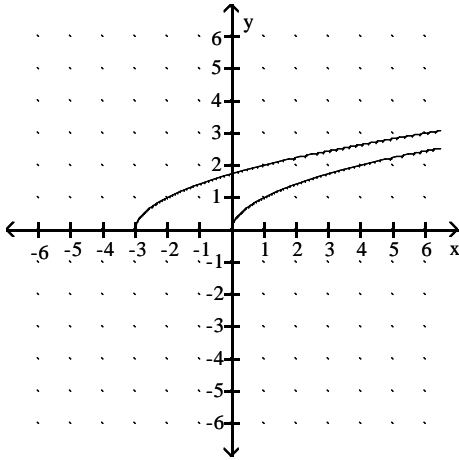

B) g shifts the graph of f 3 units to the right

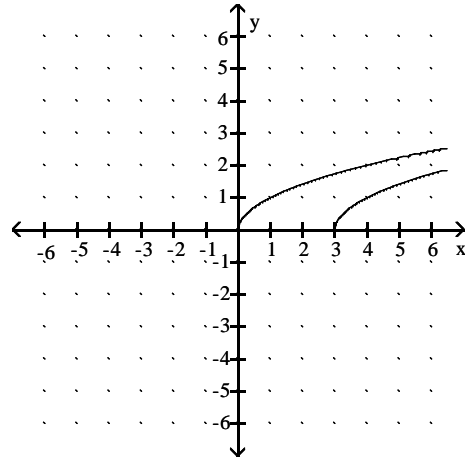

C) g shifts the graph of f vertically up 3 units

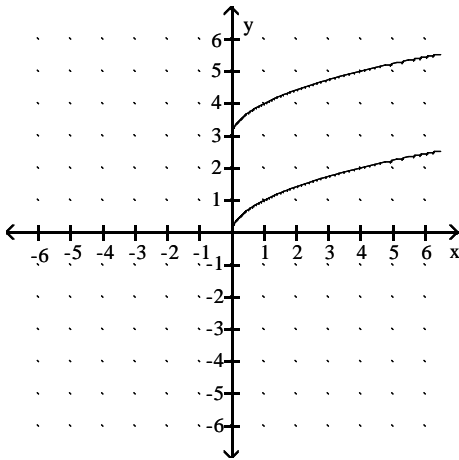

D) g shifts the graph of f vertically down 3 units

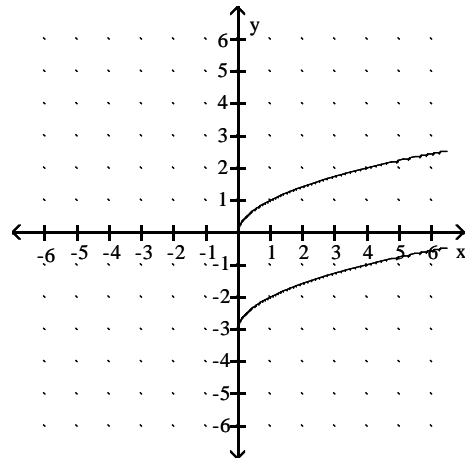

12) $f(x) = \sqrt{x}$, $g(x) = \sqrt{x-1}$

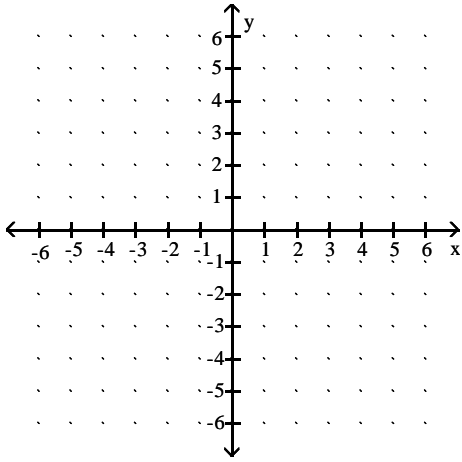

A) g shifts the graph of f 1 unit to the right

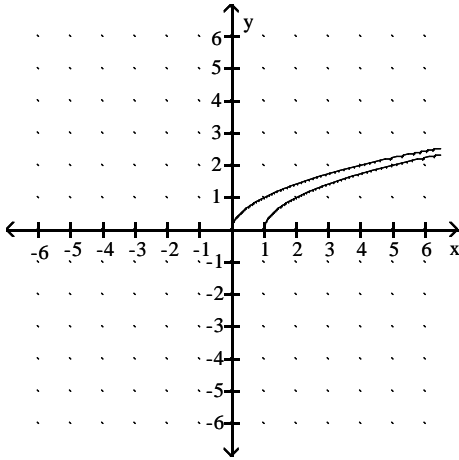

B) g shifts the graph of f 1 unit to the left

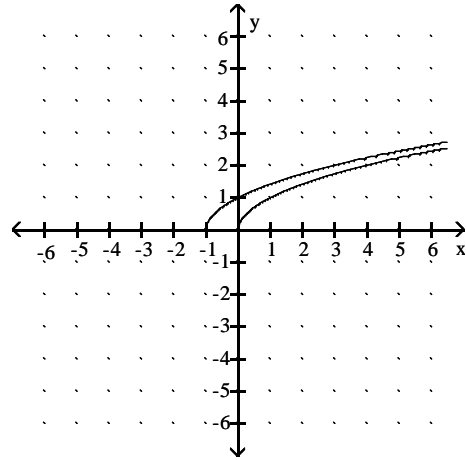

C) g shifts the graph of f vertically up 1 unit

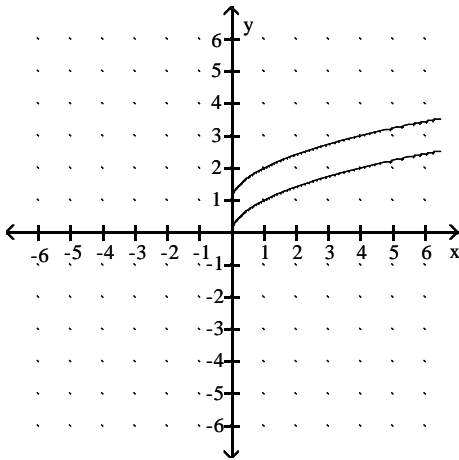

D) g shifts the graph of f vertically down 1 unit

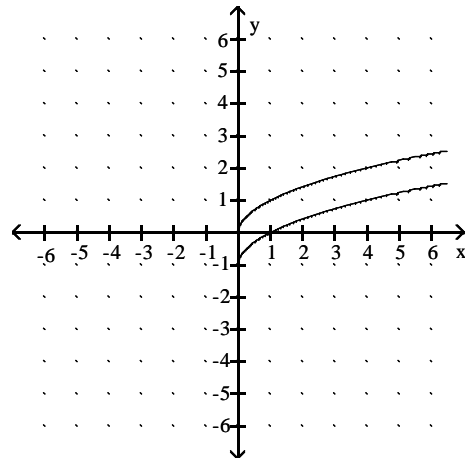

6 Use the Vertical Line Test to Identify Functions

MULTIPLE CHOICE. Choose the one alternative that best completes the statement or answers the question.

Use the vertical line test to determine whether or not the graph is a graph in which y is a function of x .

1)

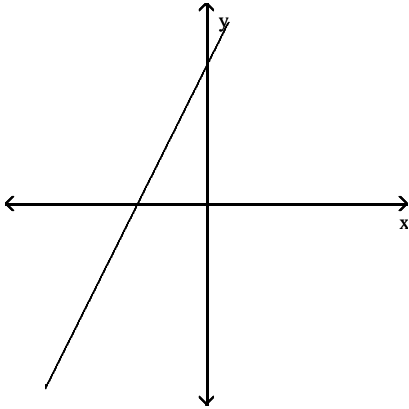

A) function

B) not a function

2)

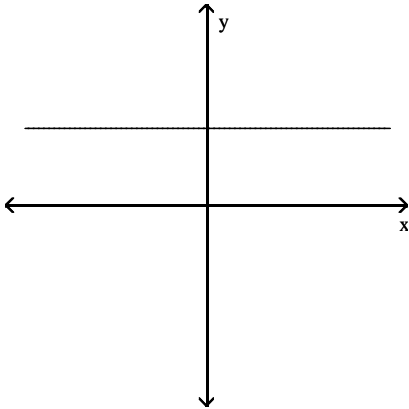

A) function

B) not a function

3)

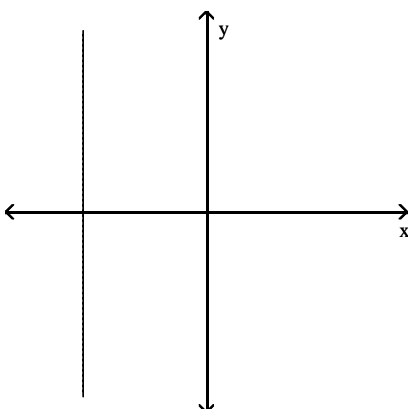

A) not a function

B) function

4)

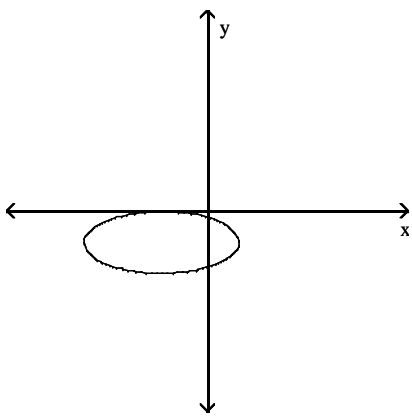

A) not a function

B) function

5)

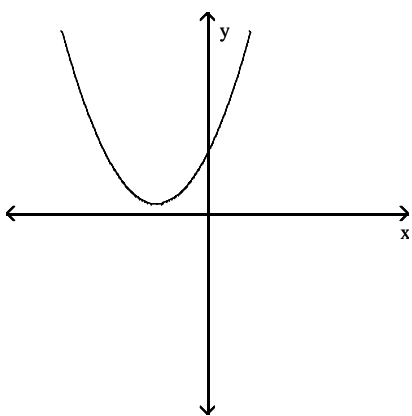

A) function

B) not a function

6)

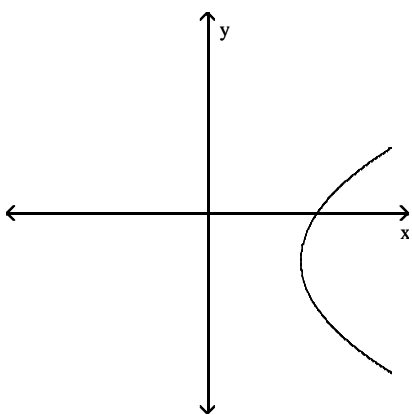

A) not a function

B) function

7)

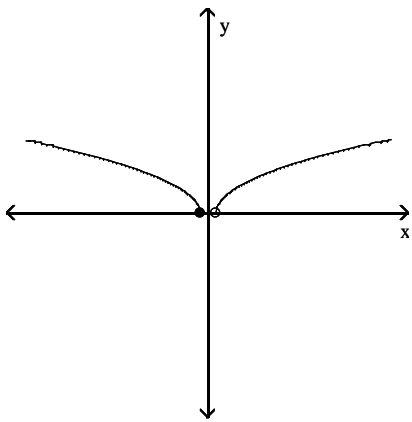

A) function

B) not a function

8)

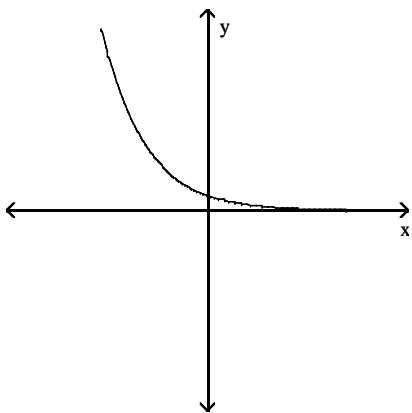

A) function

B) not a function

9)

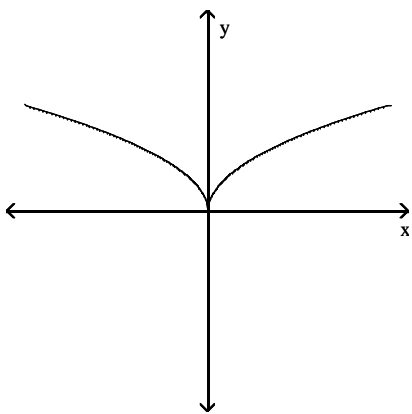

A) function

B) not a function

10)

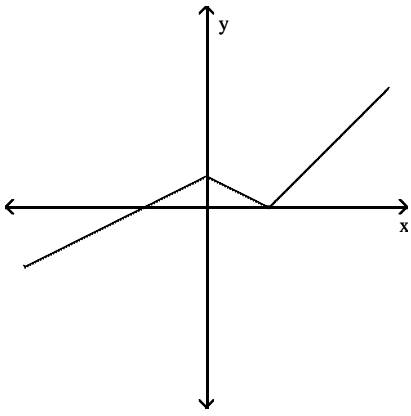

A) function

B) not a function

11)

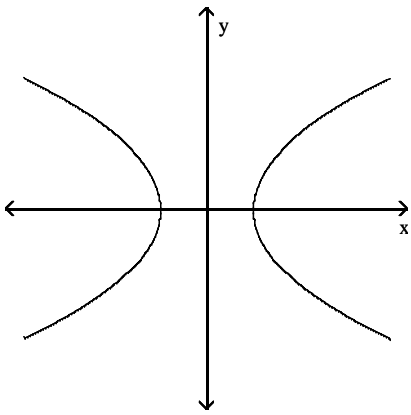

A) not a function

B) function

12)

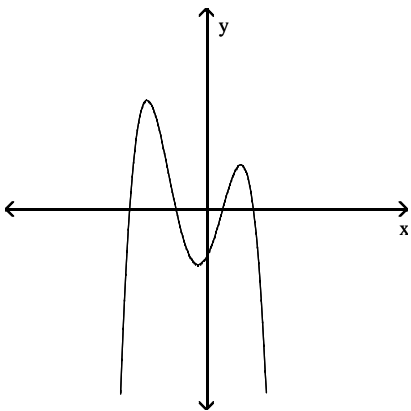

A) function

B) not a function

13)

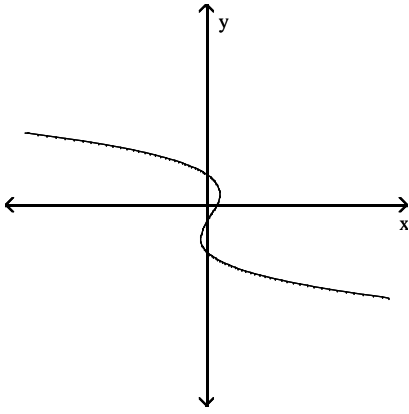

A) not a function

B) function

7 Obtain Information About a Function from Its Graph

MULTIPLE CHOICE. Choose the one alternative that best completes the statement or answers the question.

Use the graph to find the indicated function value.

1) $y = f(x)$. Find $f(-1)$

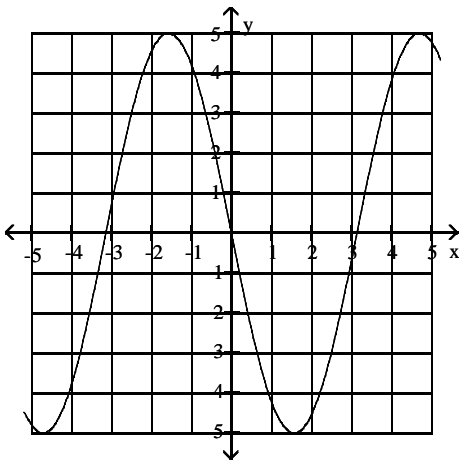

A) 4.2

B) -4.2

C) 0.2

D) -0.2

2) $y = f(x)$. Find $f(3)$.

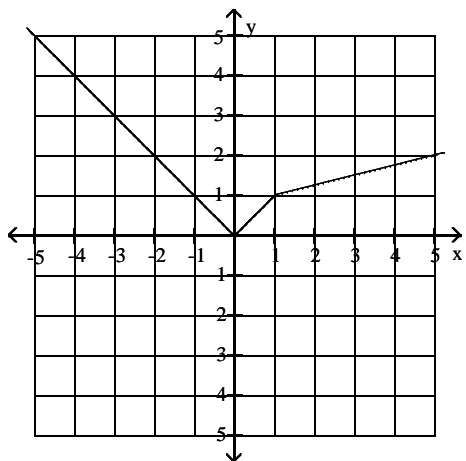

A) 1.5

B) 3

C) 9

D) -3

3) $y = f(x)$. Find $f(-5)$.

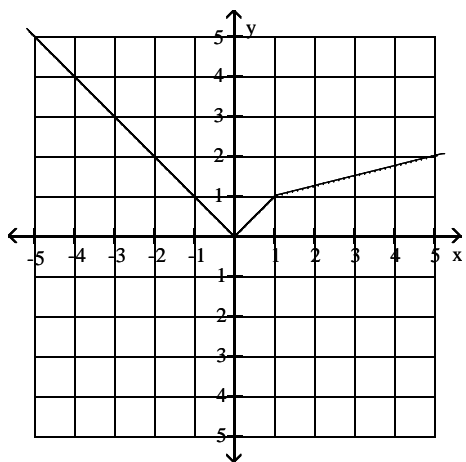

A) 5

B) -5

C) 17

D) 2

4) $y = f(x)$. Find $f(5)$

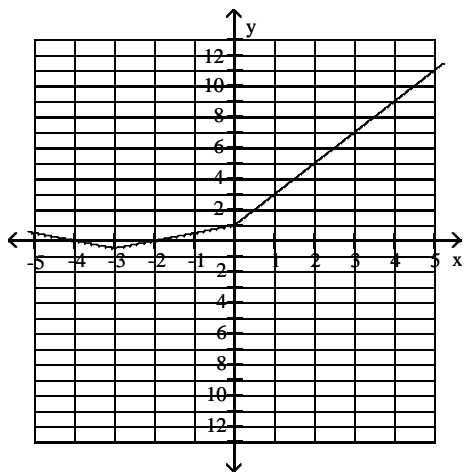

A) 11

B) 9

C) -11

D) 2

5) $y = f(x)$. Find $f(-5)$

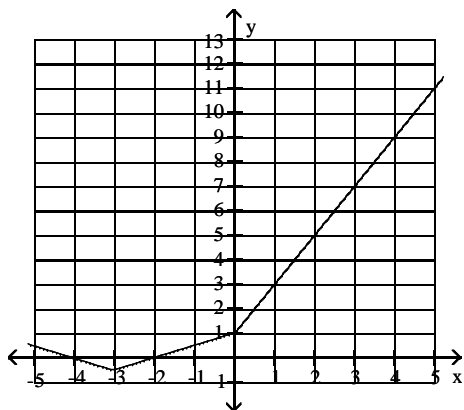

A) 0.5

B) 11

C) 4.5

D) 3.5

8 Identify the Domain and Range of a Function from Its Graph

MULTIPLE CHOICE. Choose the one alternative that best completes the statement or answers the question.

Use the graph to determine the function's domain and range.

1)

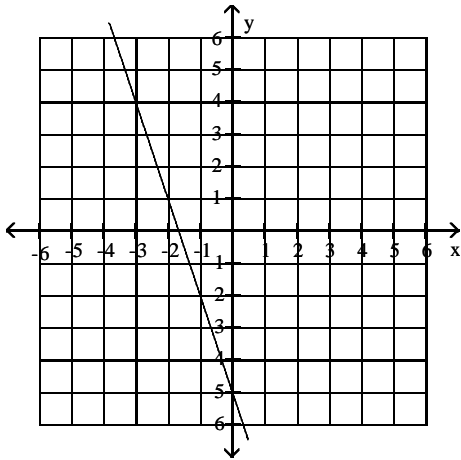

A) domain: $(-\infty, \infty)$
range: $(-\infty, \infty)$

B) domain: $(-\infty, \infty)$
range: $y = -5$

C) domain: $x = -\frac{5}{3}$
range: $(-\infty, \infty)$

D) domain: $x = -\frac{5}{3}$
range: $y = -5$

2)

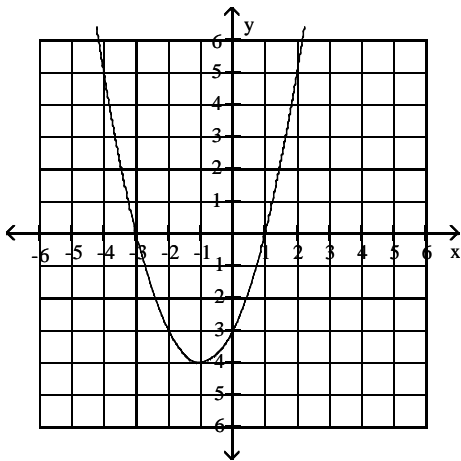

A) domain: $(-\infty, \infty)$
range: $[-4, \infty)$

B) domain: $[-1, \infty)$
range: $[-4, \infty)$

C) domain: $(-\infty, \infty)$
range: $(-\infty, \infty)$

D) domain: $(-\infty, -1)$ or $(-1, \infty)$
range: $(-\infty, -4)$ or $(-4, \infty)$

3)

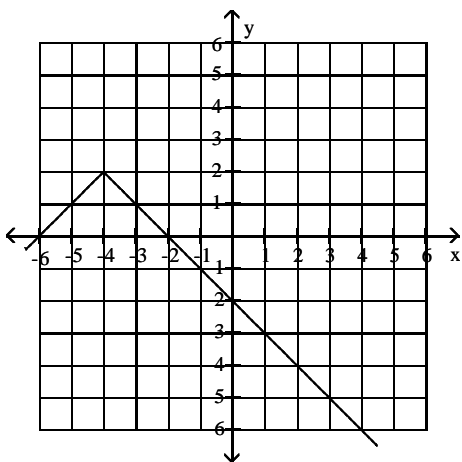

A) domain: $(-\infty, \infty)$
range: $(-\infty, 2]$

C) domain: $(-\infty, -4]$
range: $(-\infty, 2]$

B) domain: $(-\infty, \infty)$
range: $(-\infty, \infty)$

D) domain: $(-\infty, -4)$ or $(-4, \infty)$
range: $(-\infty, 2)$ or $(2, \infty)$

4)

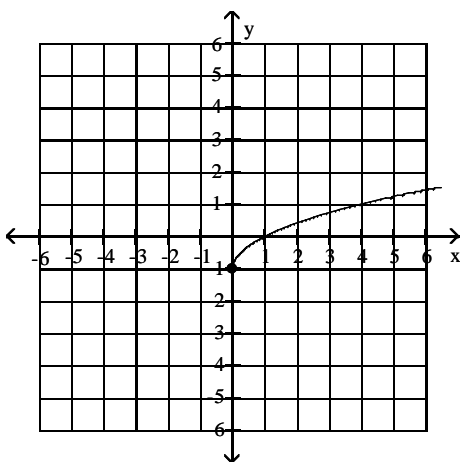

A) domain: $[0, \infty)$
range: $[-1, \infty)$

B) domain: $[0, \infty)$
range: $(-\infty, \infty)$

C) domain: $(-\infty, \infty)$
range: $[-1, \infty)$

D) domain: $[0, \infty)$
range: $[0, \infty)$

5)

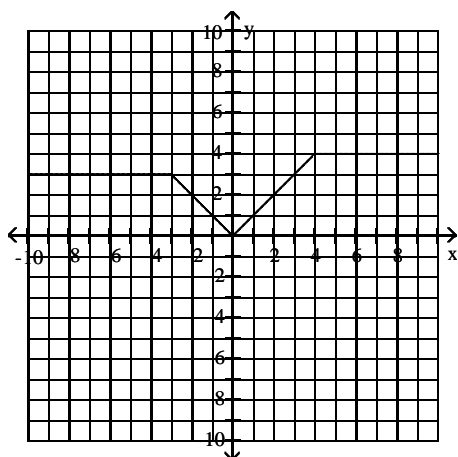

A) domain: $(-\infty, \infty)$
range: $[0, 4]$

B) domain: $(-\infty, \infty)$
range: $[3, 4]$

C) domain: $[0, 4]$
range: $(-\infty, \infty)$

D) domain: $[3, 4]$
range: $(-\infty, \infty)$

9 Identify Intercepts from a Function's Graph.

MULTIPLE CHOICE. Choose the one alternative that best completes the statement or answers the question.

Identify the intercepts.

1)

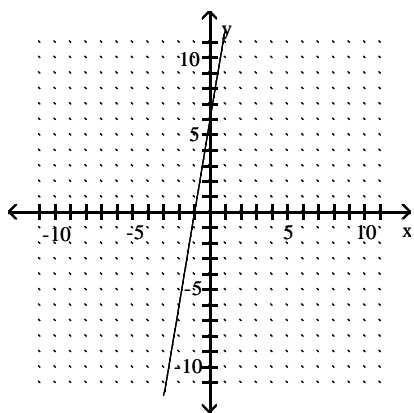

A) $(-1, 0), (0, 6)$

B) $(1, 0), (0, 6)$

C) $(-1, 0), (0, -6)$

D) $(-6, 0), (0, 6)$

2)

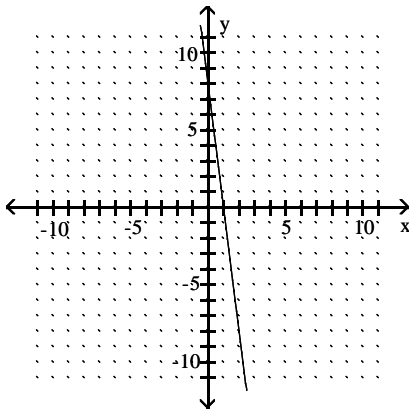

A) $(1, 0), (0, 8)$

B) $(-1, 0), (0, 8)$

C) $(1, 0), (0, -8)$

D) $(-8, 0), (0, 8)$

3)

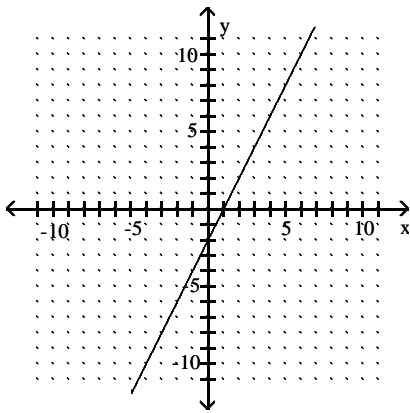

A) $(1, 0), (0, -2)$

B) $(-1, 0), (0, -2)$

C) $(1, 0), (0, 2)$

D) $(-2, 0), (0, 2)$

4)

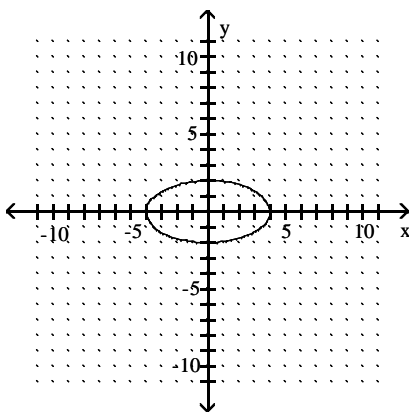

A) $(4, 0), (-4, 0), (0, 2), (0, -2)$

B) $(4, 0), (-4, 0)$

C) $(0, 2), (0, -2)$

D) $(2, 0), (-2, 0), (0, 4), (0, -4)$

5)

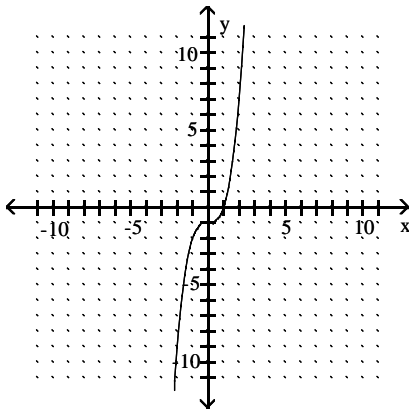

A) $(1, 0), (0, -1)$

B) $(1, 0), (0, 1)$

C) $(-1, 0), (0, -1)$

D) $(1, 1), (-1, -1)$

6)

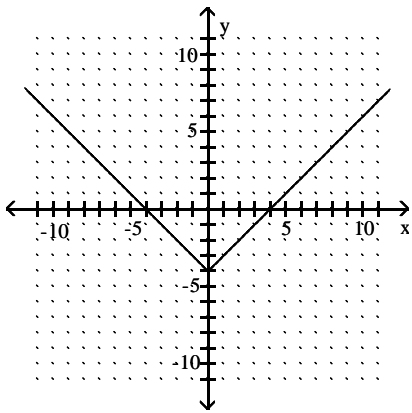

A) $(4, 0), (-4, 0), (0, -4)$

B) $(4, 0), (-4, 0)$

C) $(0, -4)$

D) $(4, 0), (-4, 0), (0, 0)$

2.2 More on Functions and Their Graphs

1 Identify Intervals on Which a Function Increases, Decreases, or is Constant

MULTIPLE CHOICE. Choose the one alternative that best completes the statement or answers the question.

Identify the intervals where the function is changing as requested.

1) Increasing

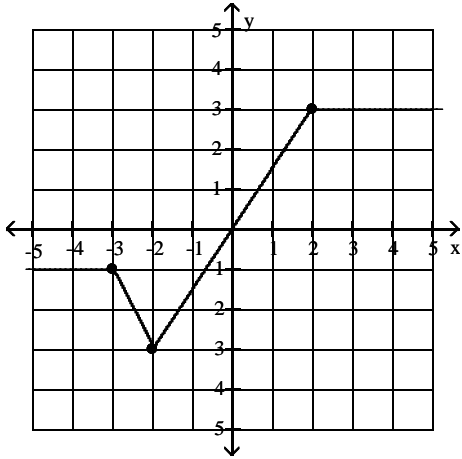

A) $(-2, 2)$

B) $(-3, 3)$

C) $(-2, \infty)$

D) $(-3, \infty)$

2) Constant

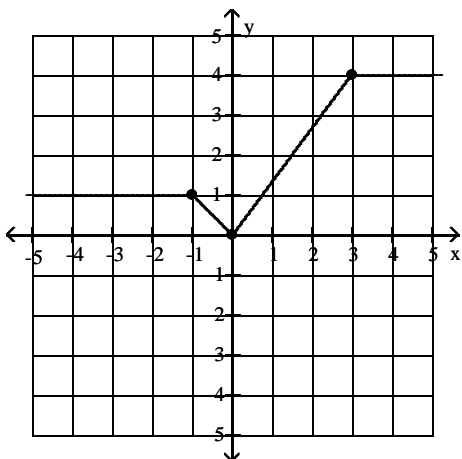

A) $(-\infty, -1)$ or $(3, \infty)$

B) $(-1, 0)$

C) $(3, \infty)$

D) $(-\infty, 0)$

3) Increasing

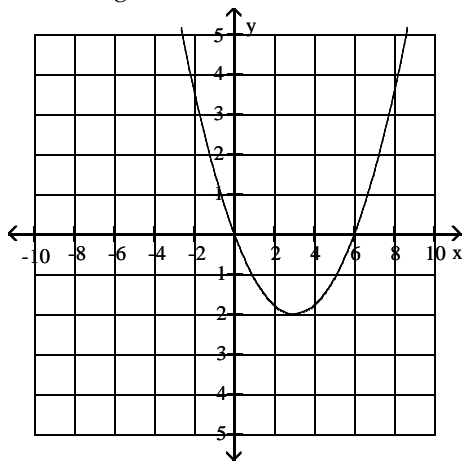

A) $(3, \infty)$

B) $(3, 6)$

C) $(-2, \infty)$

D) $(-2, 0)$

4) Increasing

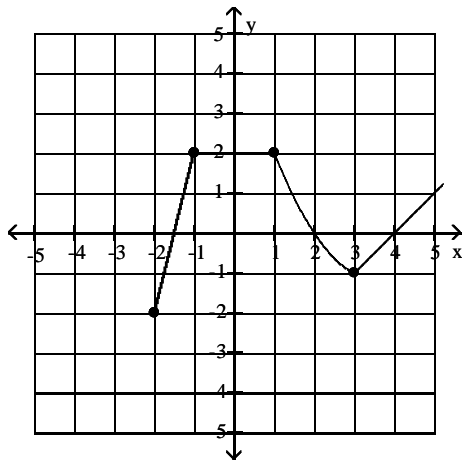

A) $(-2, -1)$ or $(3, \infty)$

B) $(-1, \infty)$

C) $(-2, 1)$

D) $(-1, 3)$

5) Increasing

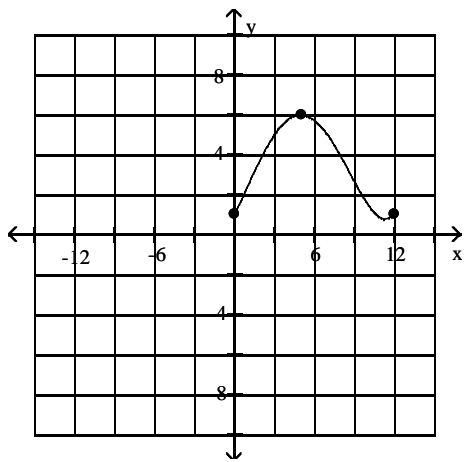

A) $(0, 5)$

B) $(1, 6)$

C) $(0, 6)$

D) $(1, 5)$

6) Increasing

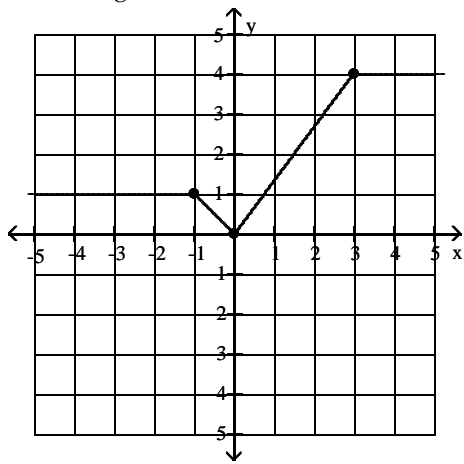

A) $(0, 3)$

B) $(-\infty, 0)$

C) $(-\infty, -1)$

D) $(-1, 0)$

7) Decreasing

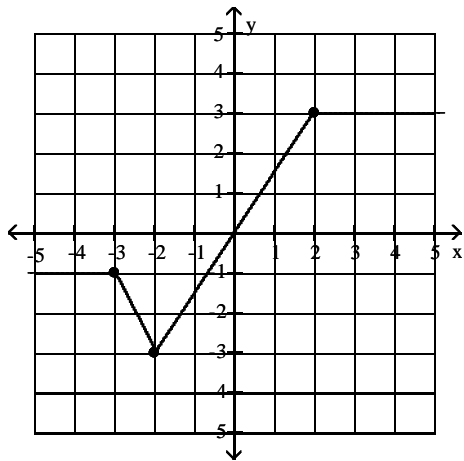

A) $(-3, -2)$

B) $(0, -2)$

C) $(-\infty, -3)$

D) $(-\infty, -2)$

8) Decreasing

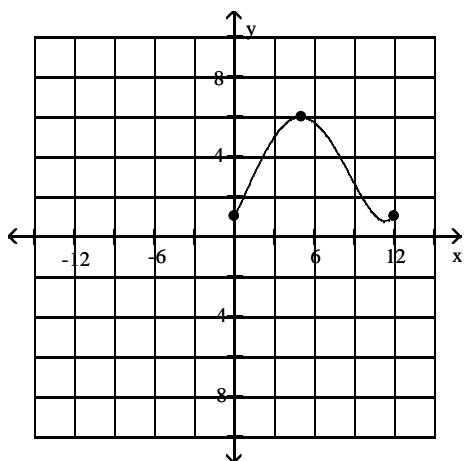

A) $(5, 12)$

B) $(6, 1)$

C) $(5, 1)$

D) $(6, 12)$

9) Decreasing

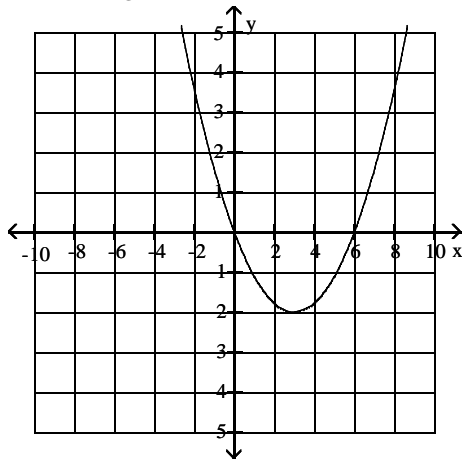

A) $(-\infty, 3)$

B) $(-\infty, -2)$

C) $(0, 3)$

D) $(0, -2)$

10) Constant

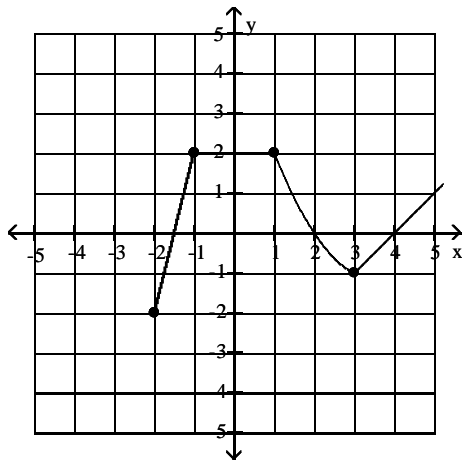

A) $(-1, 1)$

B) $(1, 2)$

C) $(-2, -1)$

D) $(2, \infty)$

2 Use Graphs to Locate Relative Maxima or Minima

MULTIPLE CHOICE. Choose the one alternative that best completes the statement or answers the question.

The graph of a function f is given. Use the graph to answer the question.

- 1) Find the numbers, if any, at which f has a relative maximum. What are the relative maxima?

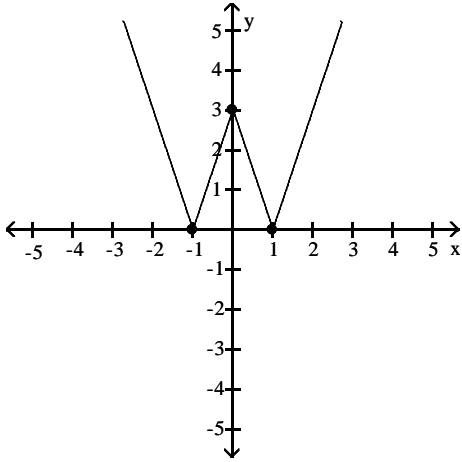

- A) f has a relative maximum at $x = 0$; the relative maximum is 3
 - B) f has a relative maximum at $x = -1$ and 1; the relative maximum is 0
 - C) f has a relative maximum at $x = 1$; the relative maximum is 3
 - D) f has no relative maximum
- 2) Find the numbers, if any, at which f has a relative minimum. What are the relative minima?

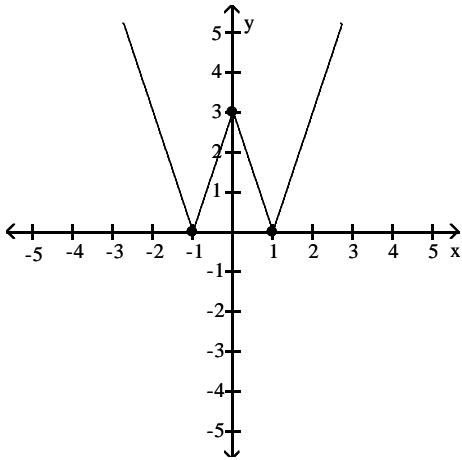

- A) f has a relative minimum at $x = -1$ and 1; the relative minimum is 0
- B) f has a relative minimum at $x = 0$; the relative minimum is 3
- C) f has a relative minimum at $x = -1$; the relative minimum is 0
- D) f has no relative minimum

3) $f(x) = x^4 - x^3$

A) Neither

B) Even

C) Odd

4) $f(x) = -5x^5 + x^3$

A) Odd

B) Even

C) Neither

5) $f(x) = x^3 + x^2 + 4$

A) Neither

B) Even

C) Odd

Use possible symmetry to determine whether the graph is the graph of an even function, an odd function, or a function that is neither even nor odd.

6)

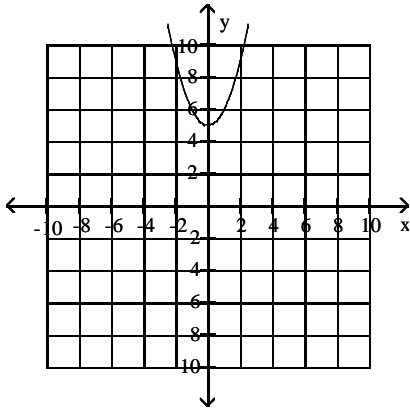

A) Even

B) Odd

C) Neither

7)

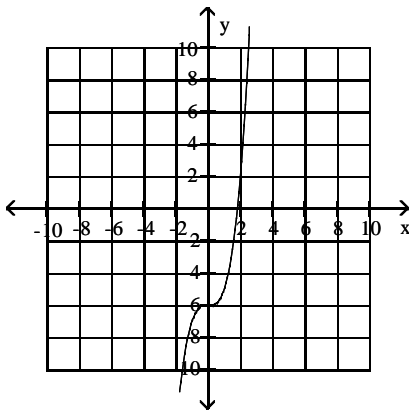

A) Neither

B) Odd

C) Even

8)

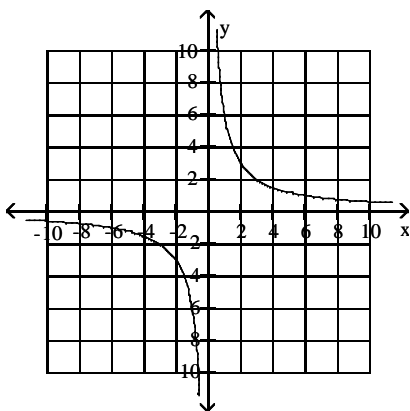

A) Odd

B) Even

C) Neither

4 Understand and Use Piecewise Functions

MULTIPLE CHOICE. Choose the one alternative that best completes the statement or answers the question.

Evaluate the piecewise function at the given value of the independent variable.

$$1) f(x) = \begin{cases} 3x + 1 & \text{if } x < -1 \\ -2x - 5 & \text{if } x \geq -1 \end{cases}; f(2)$$

A) -9

B) 1

C) -3

D) -8

$$2) f(x) = \begin{cases} x - 3 & \text{if } x > -5 \\ -(x - 3) & \text{if } x \leq -5 \end{cases}; f(-8)$$

A) 11

B) -11

C) -8

D) 20

$$3) g(x) = \begin{cases} \frac{x^2 + 5}{x + 3} & \text{if } x \neq -3 \\ x - 7 & \text{if } x = -3 \end{cases}; g(-5)$$

A) -15

B) -12

C) 0

D) -5

$$4) h(x) = \begin{cases} \frac{x^2 - 3}{x + 5} & \text{if } x \neq -5 \\ x - 1 & \text{if } x = -5 \end{cases}; h(-5)$$

A) -6

B) undefined

C) -4

D) 6

Graph the function.

$$5) f(x) = \begin{cases} x + 1 & \text{if } x < 1 \\ 4 & \text{if } x \geq 1 \end{cases}$$

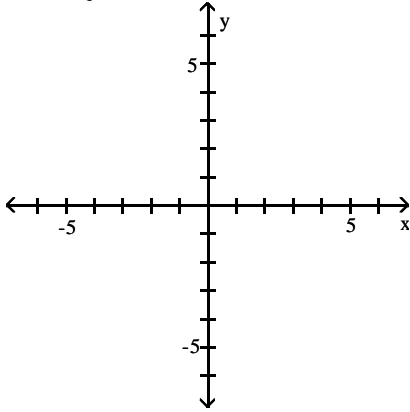

A)

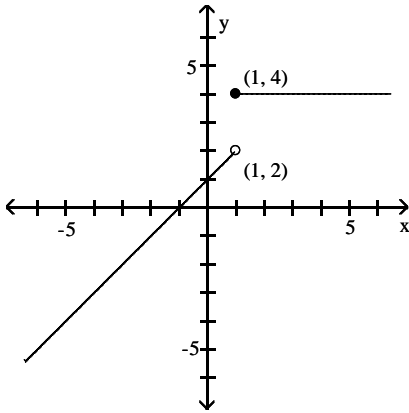

B)

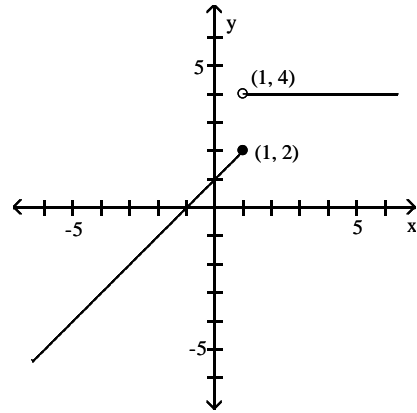

C)

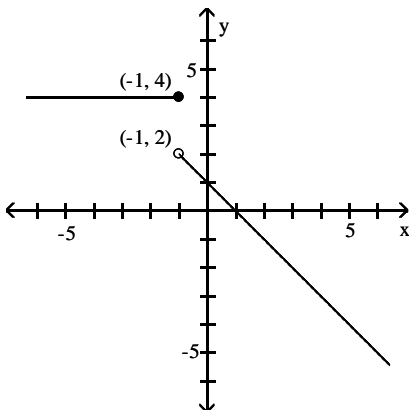

D)

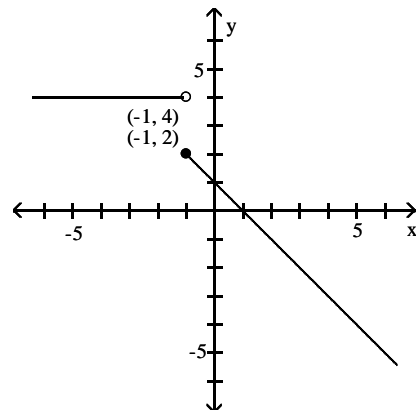

$$6) f(x) = \begin{cases} -x + 3 & \text{if } x < 2 \\ 2x - 3 & \text{if } x \geq 2 \end{cases}$$

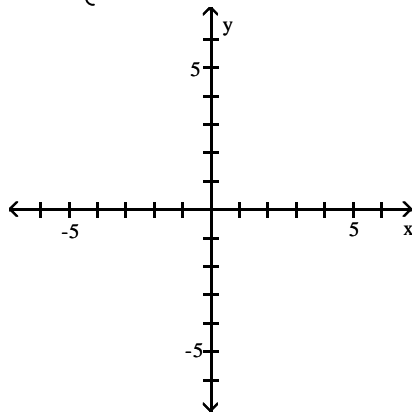

A)

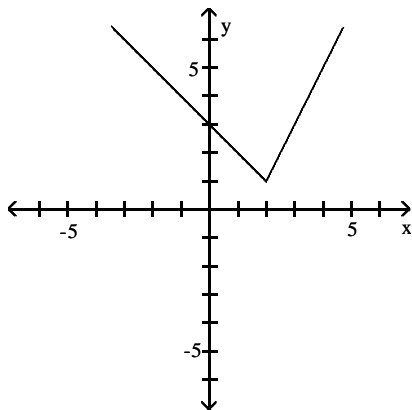

B)

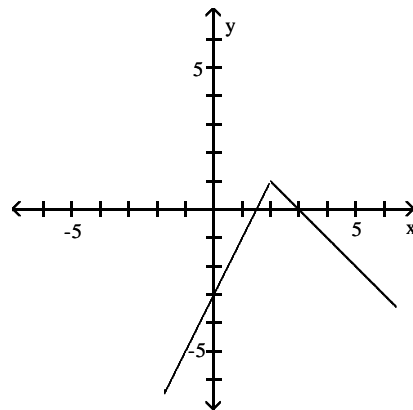

C)

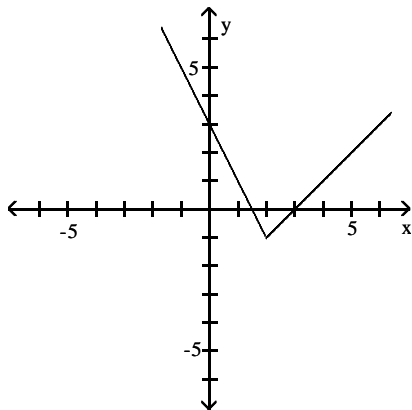

D)

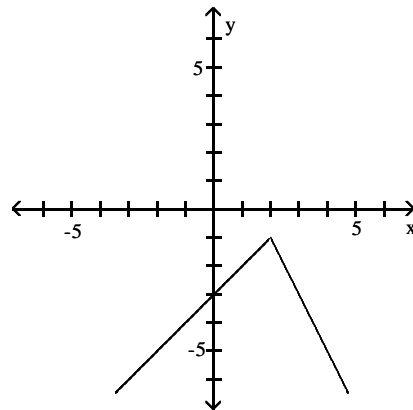

$$7) f(x) = \begin{cases} x + 1 & \text{if } -8 \leq x < 5 \\ -8 & \text{if } x = 5 \\ -x + 8 & \text{if } x > 5 \end{cases}$$

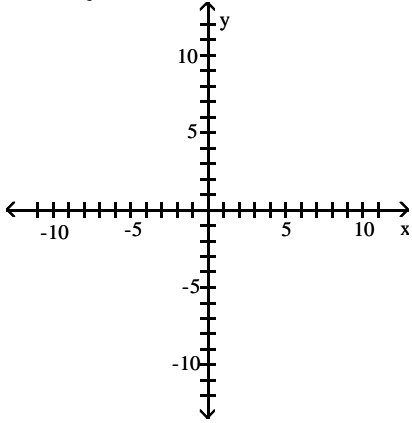

A)

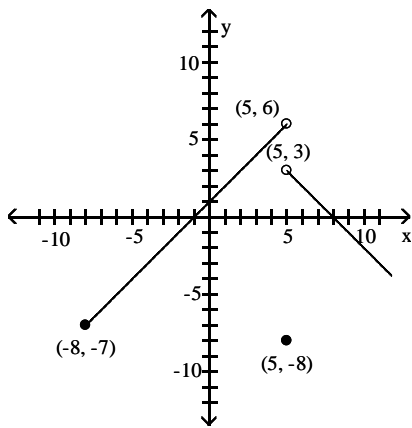

B)

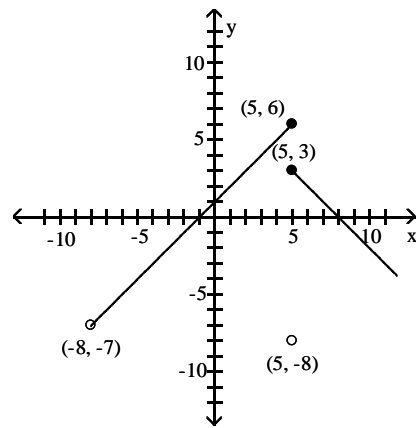

C)

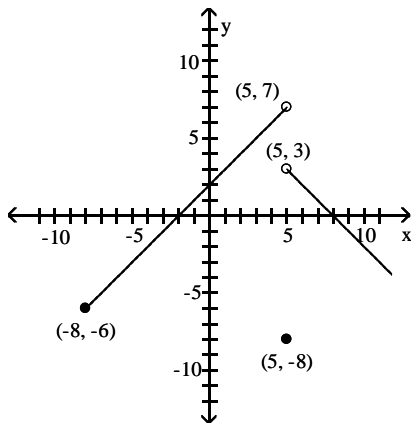

D)

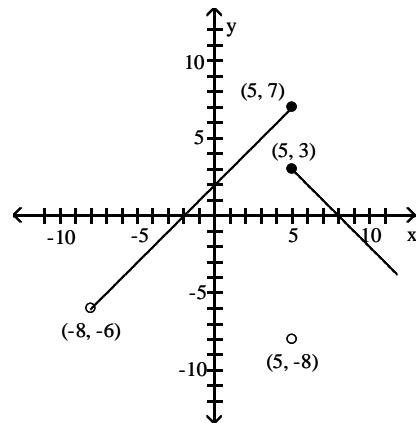

Based on the graph, find the range of $y = f(x)$.

$$8) f(x) = \begin{cases} -\frac{1}{5}x & \text{if } x \neq 0 \\ -8 & \text{if } x = 0 \end{cases}$$

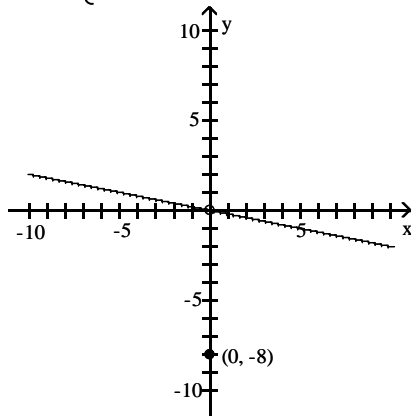

- A) $(-\infty, 0)$ or $(0, \infty)$
 C) $(-10, 10)$

- B) $(-\infty, \infty)$
 D) $(-\infty, 0)$ or $\{0\}$ or $(0, \infty)$

$$9) f(x) = \begin{cases} 4 & \text{if } -4 \leq x < -3 \\ |x| & \text{if } -3 \leq x < 8 \\ \sqrt{x} & \text{if } 8 \leq x \leq 12 \end{cases}$$

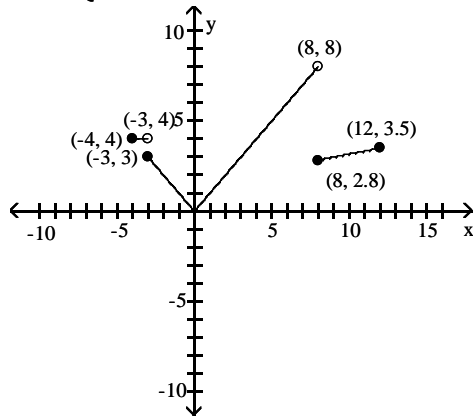

- A) $[0, 8)$ B) $[0, \infty)$ C) $[0, \sqrt{12}]$ D) $[0, 8]$

Solve the problem.

- 10) Suppose a car rental company charges \$102 for the first day and \$52 for each additional or partial day. Let $S(x)$ represent the cost of renting a car for x days. Find the value of $S(3.5)$.
 A) \$258 B) \$232 C) \$284 D) \$182
- 11) Suppose a life insurance policy costs \$20 for the first unit of coverage and then \$5 for each additional unit of coverage. Let $C(x)$ be the cost for insurance of x units of coverage. What will 10 units of coverage cost?
 A) \$65 B) \$70 C) \$50 D) \$30
- 12) A salesperson gets a commission of \$600 for the first \$10,000 of sales, and then \$300 for each additional \$10,000 or partial of sales. Let $S(x)$ represent the commission on x dollars of sales. Find the value of $S(45,000)$.
 A) \$1800 B) \$1650 C) 1950 D) \$1350

SHORT ANSWER. Write the word or phrase that best completes each statement or answers the question.

- 13) A gas company has the following rate schedule for natural gas usage in single-family residences:

| | |
|--------------------------|-----------------|
| Monthly service charge | \$8.80 |
| Per therm service charge | |
| 1st 25 therms | \$0.6686/therm |
| Over 25 therms | \$0.85870/therm |

What is the charge for using 25 therms in one month?
 What is the charge for using 45 therms in one month?
 Construct a function that gives the monthly charge C for x therms of gas.

- 14) An electric company has the following rate schedule for electricity usage in single-family residences:

| | |
|-----------------------------|--------------|
| Monthly service charge | \$4.93 |
| Per kilowatt service charge | |
| 1st 300 kilowatts | \$0.11589/kW |
| Over 300 kilowatts | \$0.13321/kW |

What is the charge for using 300 kilowatts in one month?
 What is the charge for using 375 kilowatts in one month?
 Construct a function that gives the monthly charge C for x kilowatts of electricity.

- 15) One Internet service provider has the following rate schedule for high-speed Internet service:

| | |
|------------------------|-------------|
| Monthly service charge | \$18.00 |
| 1st 50 hours of use | free |
| Next 50 hours of use | \$0.25/hour |
| Over 100 hours of use | \$1.00/hour |

What is the charge for 50 hours of high-speed Internet use in one month?
 What is the charge for 75 hours of high-speed Internet use in one month?
 What is the charge for 135 hours of high-speed Internet use in one month?

- 16) The wind chill factor represents the equivalent air temperature at a standard wind speed that would produce the same heat loss as the given temperature and wind speed. One formula for computing the equivalent temperature is

$$W(t) = \begin{cases} t & \text{if } 0 \leq v < 1.79 \\ 33 - \frac{(10.45 + 10\sqrt{v} - v)(33 - t)}{22.04} & \text{if } 1.79 \leq v < 20 \\ 33 - 1.5958(33 - t) & \text{if } v \geq 20 \end{cases}$$

where v represents the wind speed (in meters per second) and t represents the air temperature ($^{\circ}\text{C}$). Compute the wind chill for an air temperature of 15°C and a wind speed of 12 meters per second. (Round the answer to one decimal place.)

17) A cellular phone plan had the following schedule of charges:

| | |
|---|--------------------|
| Basic service, including 100 minutes of calls | \$20.00 per month |
| 2nd 100 minutes of calls | \$0.075 per minute |
| Additional minutes of calls | \$0.10 per minute |

What is the charge for 200 minutes of calls in one month?

What is the charge for 250 minutes of calls in one month?

Construct a function that relates the monthly charge C for x minutes of calls.

5 Find and Simplify a Function's Difference Quotient

MULTIPLE CHOICE. Choose the one alternative that best completes the statement or answers the question.

Find and simplify the difference quotient $\frac{f(x+h) - f(x)}{h}$, $h \neq 0$ for the given function.

1) $f(x) = 6x - 2$

A) 6

B) $6 + \frac{-4}{h}$

C) $6 + \frac{12(x-2)}{h}$

D) 0

2) $f(x) = 7x^2$

A) $7(2x+h)$

B) $\frac{14}{h} + x + 7h$

C) $\frac{7(2x^2 + 2xh + h^2)}{h}$

D) 7

3) $f(x) = 5$

A) 0

B) 1

C) $1 + \frac{10}{h}$

D) 5

4) $f(x) = \frac{1}{6x}$

A) $\frac{-1}{6x(x+h)}$

B) $\frac{-1}{x(x+h)}$

C) $\frac{1}{6x}$

D) 0

5) $f(x) = x^2 + 2x - 3$

A) $2x + h + 2$

B) $\frac{2x^2 + 2x + 2xh + h^2 + h - 6}{h}$

C) $2x + h - 3$

D) 1

2.3 Linear Functions and Slope

1 Calculate a Line's Slope

MULTIPLE CHOICE. Choose the one alternative that best completes the statement or answers the question.

Find the slope of the line that goes through the given points.

1) $(3, -5), (-9, -8)$

A) $\frac{1}{4}$

B) 4

C) $\frac{13}{6}$

D) $-\frac{1}{4}$

- 2) $(-7, 6), (-7, -9)$
 A) Undefined B) 0 C) $\frac{3}{14}$ D) $-\frac{15}{14}$
- 3) $(-1, 4), (5, 4)$
 A) 0 B) Undefined C) 2 D) $\frac{4}{3}$
- 4) $(-2, -6), (-9, -17)$
 A) $\frac{11}{7}$ B) $\frac{7}{11}$ C) $\frac{23}{11}$ D) $-\frac{11}{7}$
- 5) $(-8, 8), (-5, 2)$
 A) -2 B) $\frac{16}{7}$ C) $-\frac{1}{2}$ D) $\frac{7}{16}$
- 6) $(-3, -7), (9, -7)$
 A) 0 B) 1 C) 4 D) -4
- 7) $(0, -2)$ and $(\frac{3}{5}, -4)$
 A) $-\frac{10}{3}$ B) -10 C) $-\frac{3}{10}$ D) $\frac{3}{10}$
- 8) $(\frac{2}{5}, 1)$ and $(\frac{2}{5}, -1)$
 A) Undefined B) 0 C) $-\frac{3}{5}$ D) $-\frac{5}{3}$

2 Write the Point-Slope Form of the Equation of a Line

MULTIPLE CHOICE. Choose the one alternative that best completes the statement or answers the question.

Use the given conditions to write an equation for the line in point-slope form.

- 1) Slope = -4, passing through $(7, 4)$
 A) $y - 4 = -4(x - 7)$ B) $y + 4 = -4(x + 7)$ C) $x - 4 = -4(y - 7)$ D) $y = -4x + 32$
- 2) Slope = 4, passing through $(-3, 7)$
 A) $y - 7 = 4(x + 3)$ B) $y + 7 = 4(x - 3)$ C) $x - 7 = 4(y + 3)$ D) $y = 4x + 19$
- 3) Slope = $\frac{6}{7}$, passing through $(8, 7)$
 A) $y - 7 = \frac{6}{7}(x - 8)$ B) $y + 7 = \frac{6}{7}(x + 8)$ C) $x - 7 = \frac{6}{7}(y - 8)$ D) $y = \frac{6}{7}x + 8$

4) Passing through (5, 8) and (3, 4)

A) $y - 8 = 2(x - 5)$ or $y - 4 = 2(x - 3)$

C) $y + 8 = 2(x + 5)$ or $y + 4 = 2(x + 3)$

B) $y - 8 = 2(x - 3)$ or $y - 4 = 2(x - 5)$

D) $y - 8 = 5(x + 5)$ or $y - 4 = 3(x - 8)$

5) Passing through (-2, -2) and (-5, -3)

A) $y + 2 = \frac{1}{3}(x + 2)$ or $y + 3 = \frac{1}{3}(x + 5)$

C) $y - 2 = \frac{1}{3}(x - 2)$ or $y - 3 = \frac{1}{3}(x - 5)$

B) $y + 2 = \frac{1}{3}(x + 5)$ or $y + 3 = \frac{1}{3}(x + 2)$

D) $y + 2 = \frac{1}{3}x - 2$ or $y + 3 = \frac{1}{3}x + 2$

6) Passing through (1, -5) with x-intercept = -1

A) $y + 5 = -\frac{5}{2}(x - 1)$ or $y = -\frac{5}{2}(x + 1)$

C) $y + 5 = -\frac{5}{2}(x - 1)$ or $y = -\frac{5}{2}(x - 1)$

B) $y - 5 = -\frac{5}{2}(x + 1)$ or $y = -\frac{5}{2}(x + 1)$

D) $y - 1 = -\frac{5}{2}x$ or $y - 5 = -\frac{5}{2}(x + 1)$

3 Write and Graph the Slope-Intercept Form of the Equation of a Line

MULTIPLE CHOICE. Choose the one alternative that best completes the statement or answers the question.

Use the given conditions to write an equation for the line in slope-intercept form.

1) Slope = -4, passing through (8, 4)

A) $y = -4x + 36$

B) $y = -4x - 36$

C) $y - 4 = -4x - 8$

D) $y - 4 = x - 8$

2) Slope = -3, passing through (-5, 3)

A) $y = -3x - 12$

B) $y = -3x + 12$

C) $y - 3 = -3x + 5$

D) $y - 3 = x + 5$

3) Slope = $\frac{2}{3}$, passing through (7, 3)

A) $y = \frac{2}{3}x - \frac{5}{3}$

B) $y = \frac{2}{3}x + \frac{5}{3}$

C) $y = mx - \frac{5}{3}$

D) $y = \frac{2}{3}x + 7$

4) Slope = $\frac{3}{4}$, y-intercept = 2

A) $f(x) = \frac{3}{4}x + 2$

B) $f(x) = -\frac{3}{4}x - 2$

C) $f(x) = \frac{3}{4}x - 2$

D) $f(x) = \frac{4}{3}x + \frac{8}{3}$

5) Passing through (4, 8) and (7, 3)

A) $y = -\frac{5}{3}x + \frac{44}{3}$

B) $y = mx + \frac{44}{3}$

C) $y - 8 = -\frac{5}{3}(x - 4)$

D) $y = \frac{5}{3}x + \frac{44}{3}$

6) Passing through (1, -7) and (-1, 2)

A) $y = -\frac{9}{2}x - \frac{5}{2}$

B) $y = mx - \frac{5}{2}$

C) $y + 7 = -\frac{9}{2}(x - 1)$

D) $y = \frac{9}{2}x - \frac{5}{2}$

7) Passing through $(-8, -2)$ and $(-5, -7)$

A) $y = -\frac{5}{3}x - \frac{46}{3}$

B) $y = mx - \frac{46}{3}$

C) $y + 2 = -\frac{5}{3}(x + 8)$

D) $y = \frac{5}{3}x - \frac{46}{3}$

Graph the line whose equation is given.

8) $y = 2x - 2$

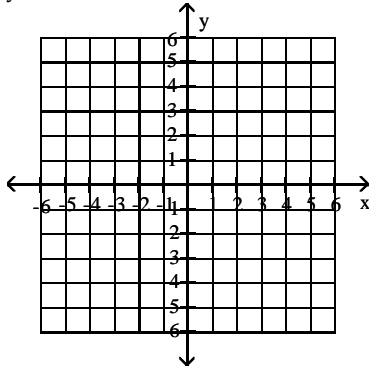

A)

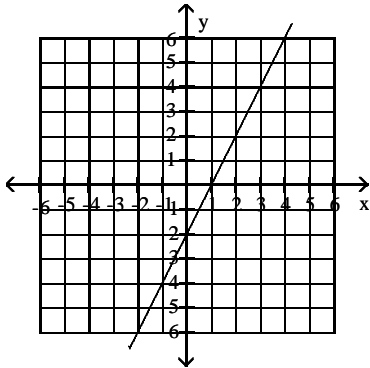

B)

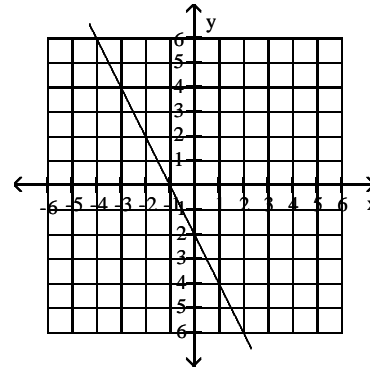

C)

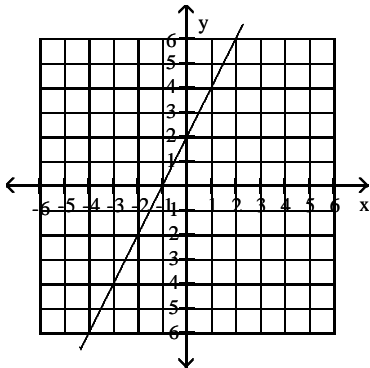

D)

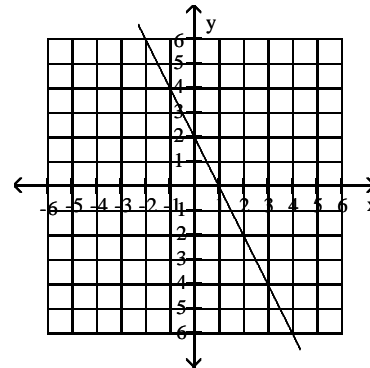

9) $y = -3x - 3$

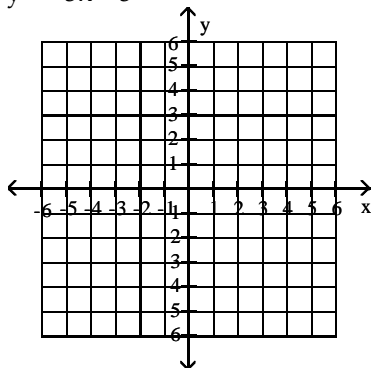

A)

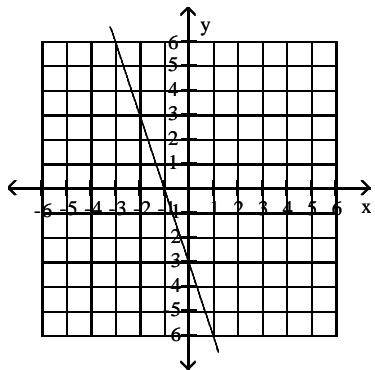

B)

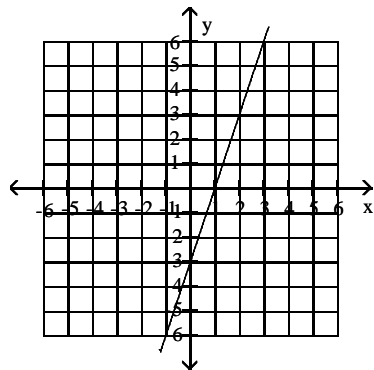

C)

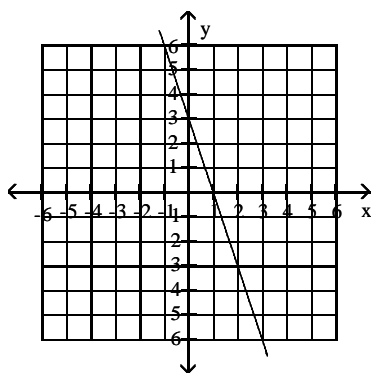

D)

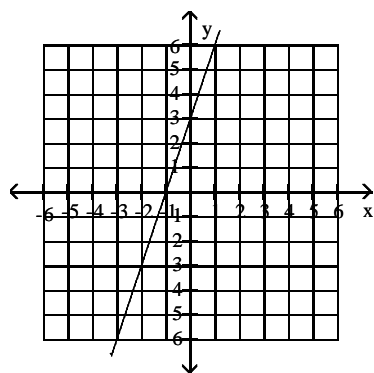

$$10) y = \frac{3}{5}x + 1$$

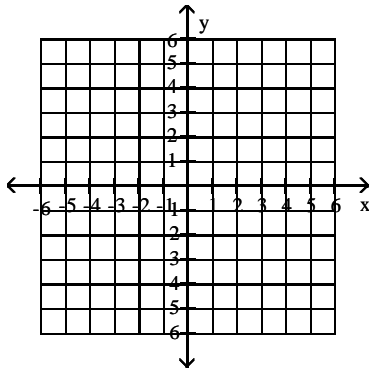

A)

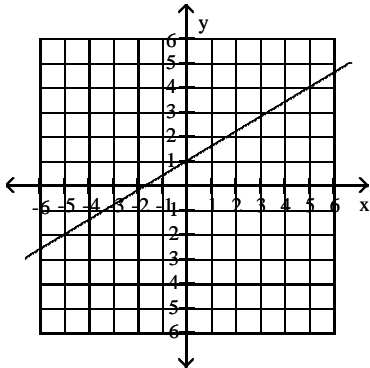

B)

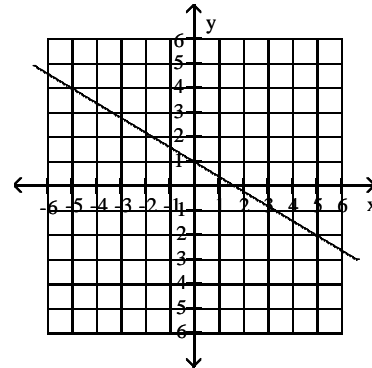

C)

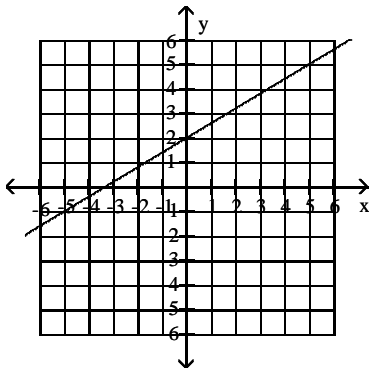

D)

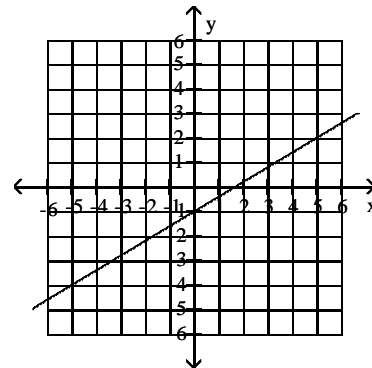

11) $y = -\frac{3}{5}x - 1$

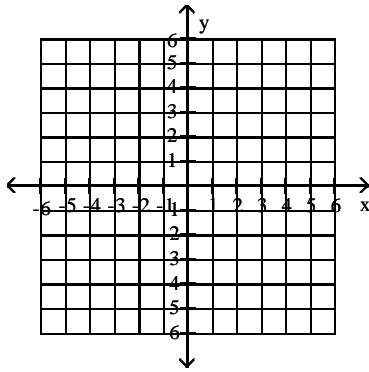

A)

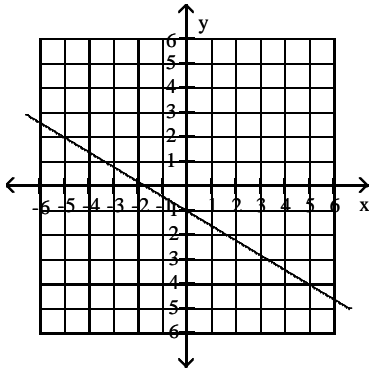

B)

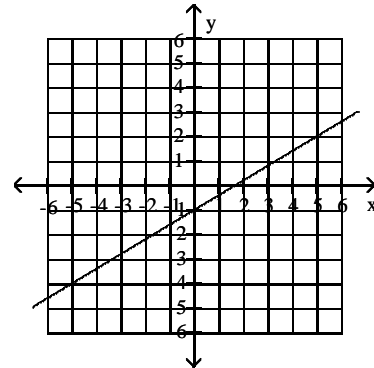

C)

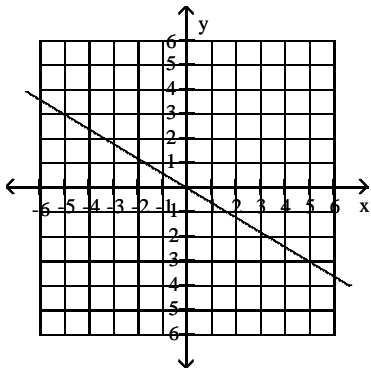

D)

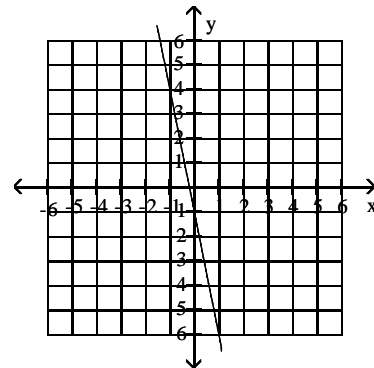

4 Graph Horizontal or Vertical Lines

MULTIPLE CHOICE. Choose the one alternative that best completes the statement or answers the question.

Graph the equation in the rectangular coordinate system.

1) $x = 5$

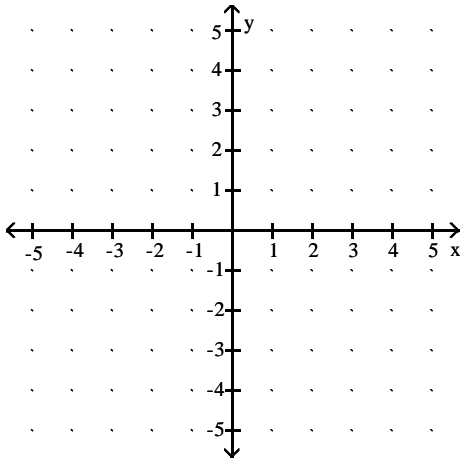

A)

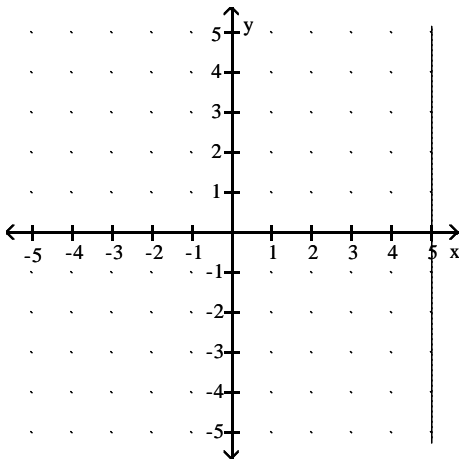

B)

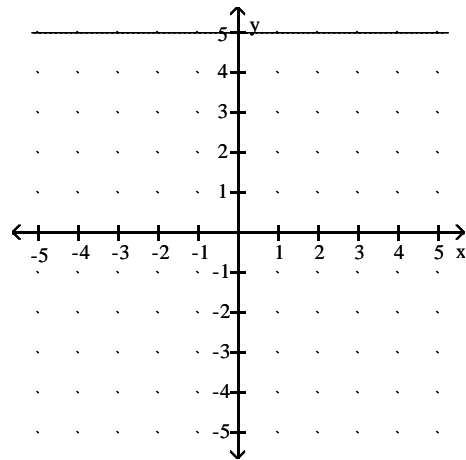

C)

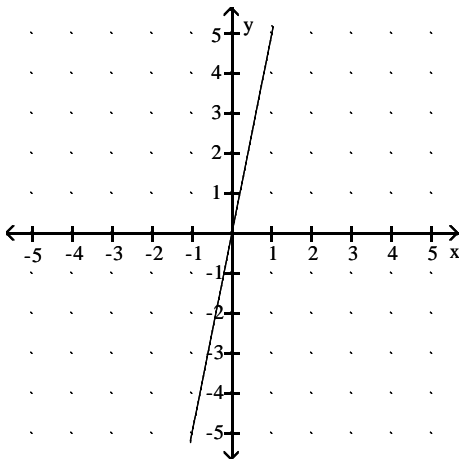

D)

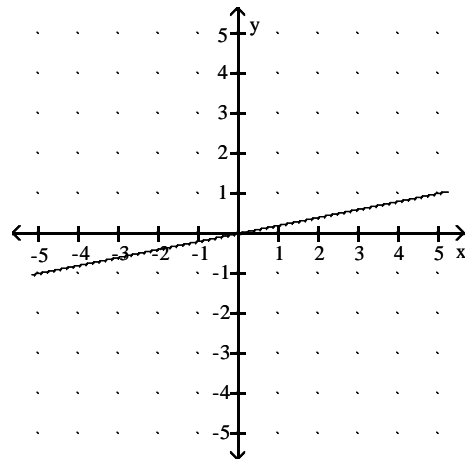

2) $y = 5$

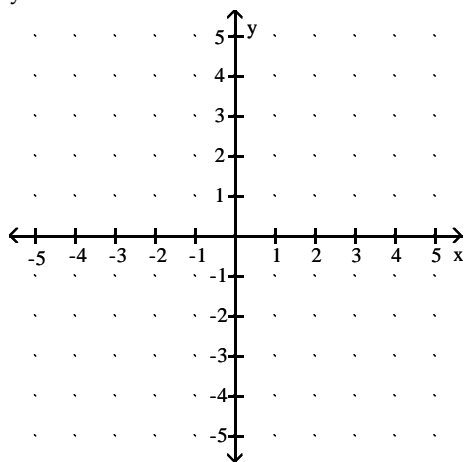

A)

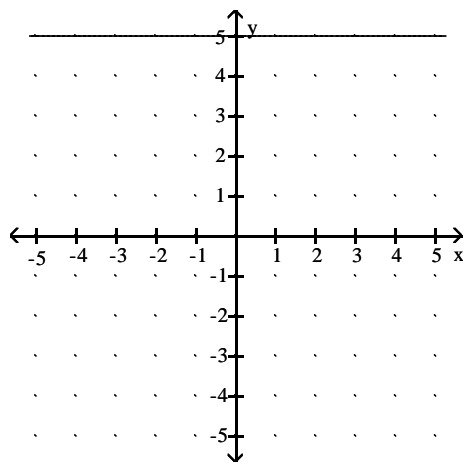

B)

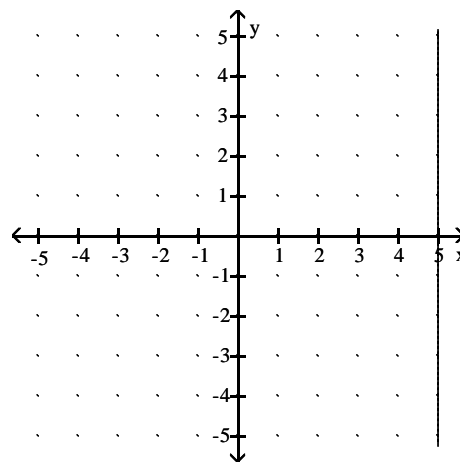

C)

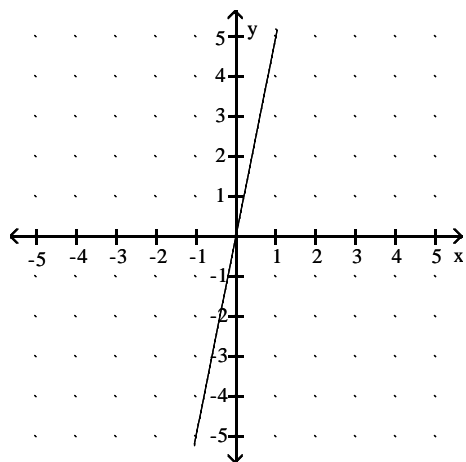

D)

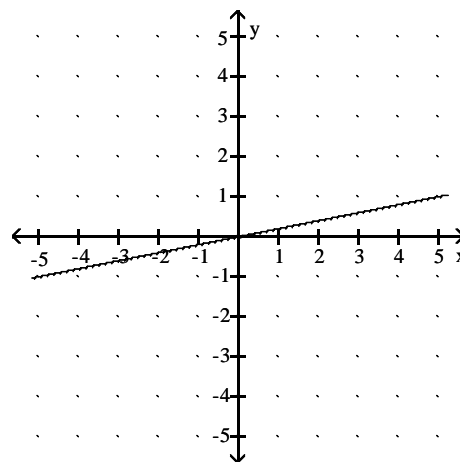

3) $f(x) = -3$

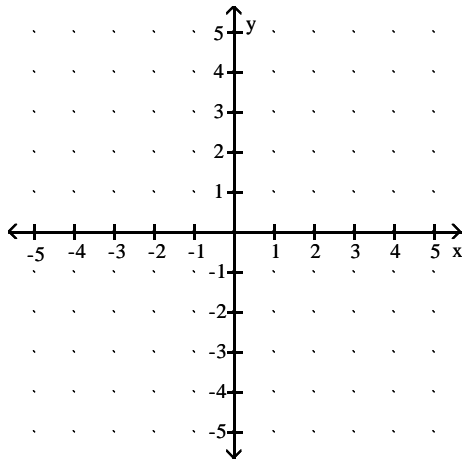

A)

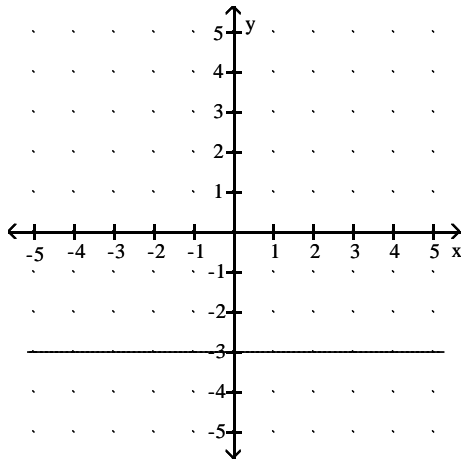

B)

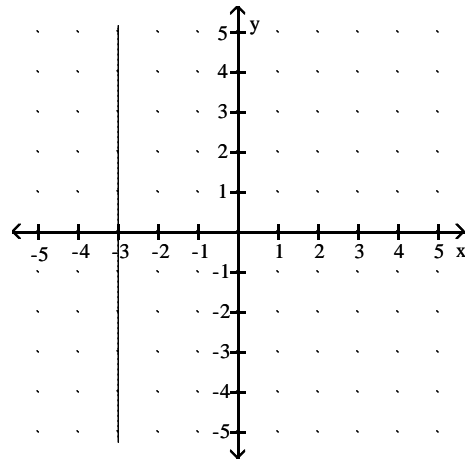

C)

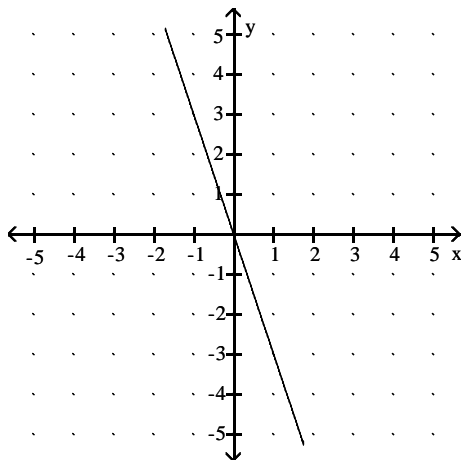

D)

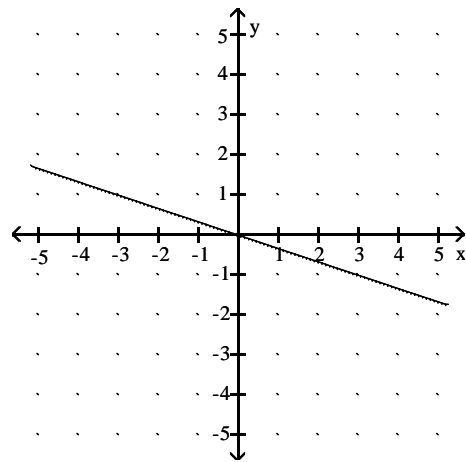

4) $3y = 3$

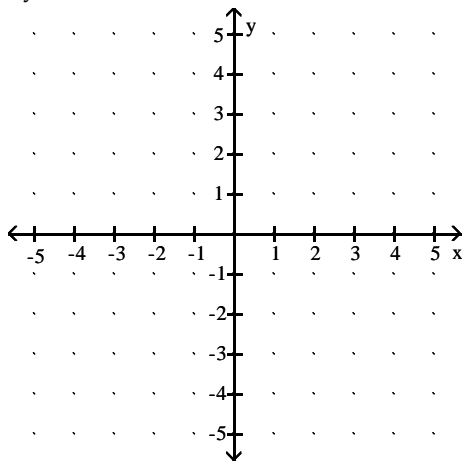

A)

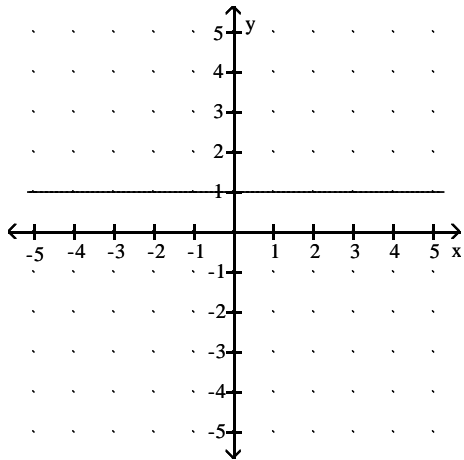

B)

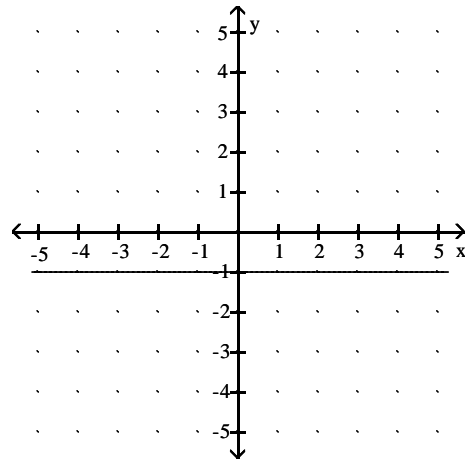

C)

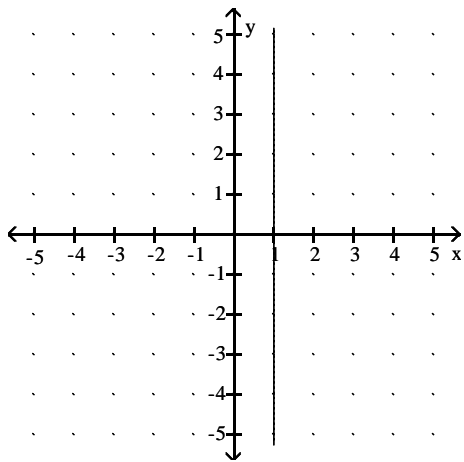

D)

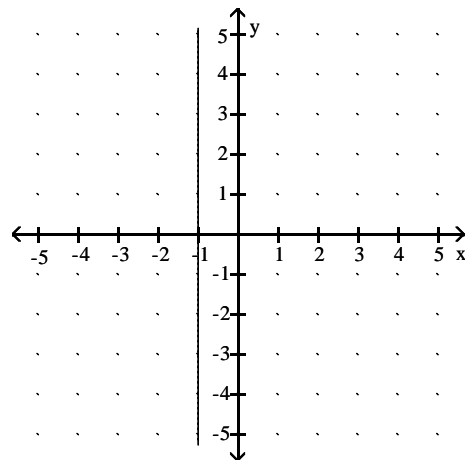

5) $4x = 8$

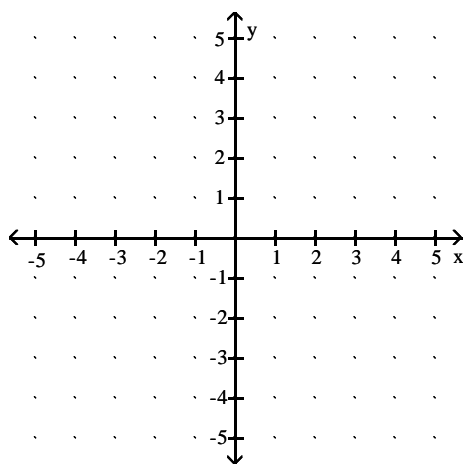

A)

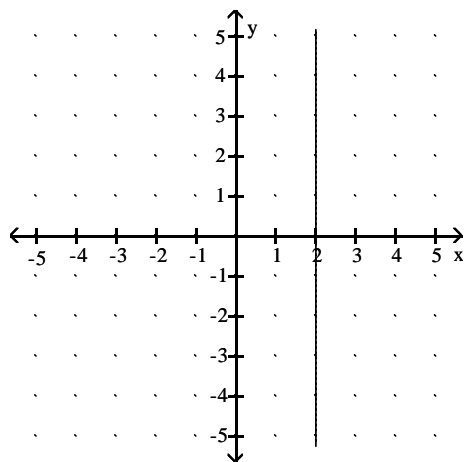

B)

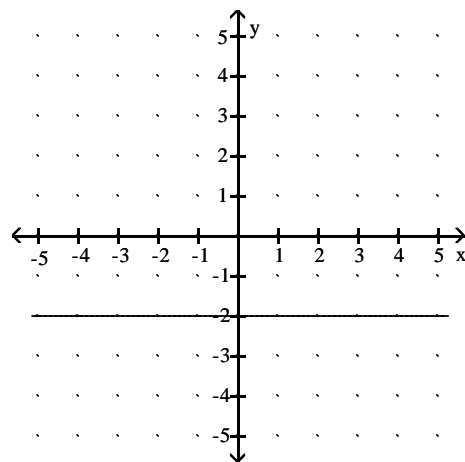

C)

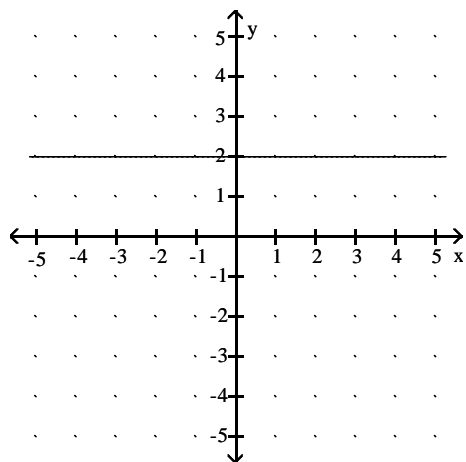

D)

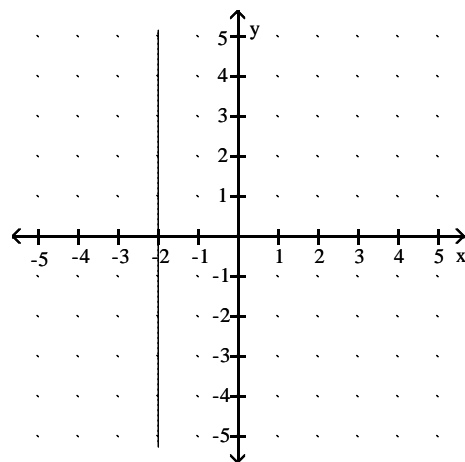

6) $2y = 6$

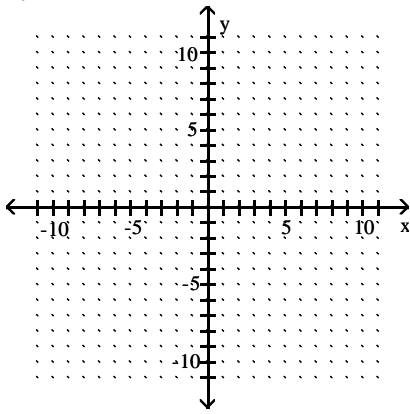

A)

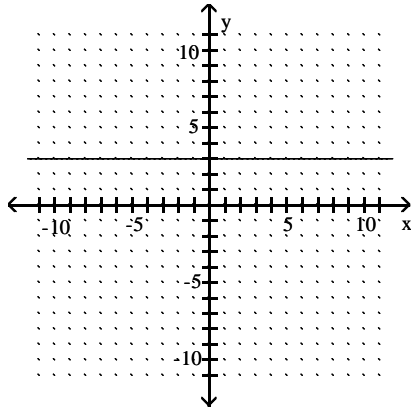

B)

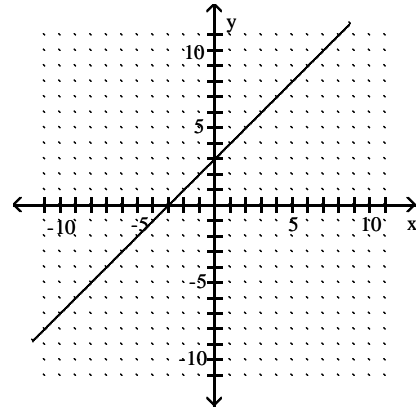

C)

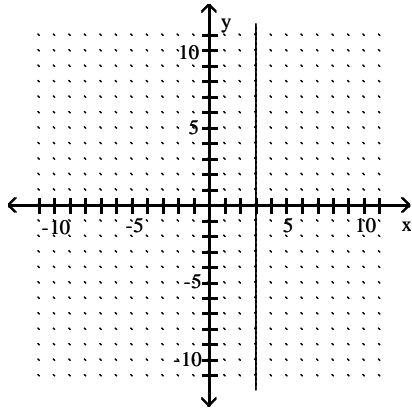

D)

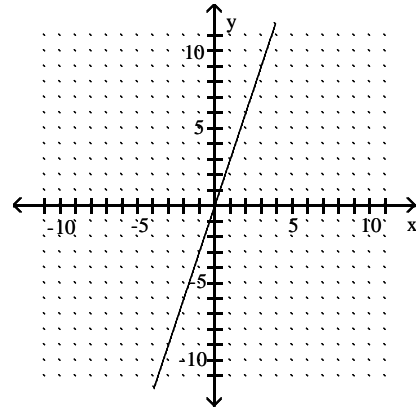

7) $6x - 8 = -38$

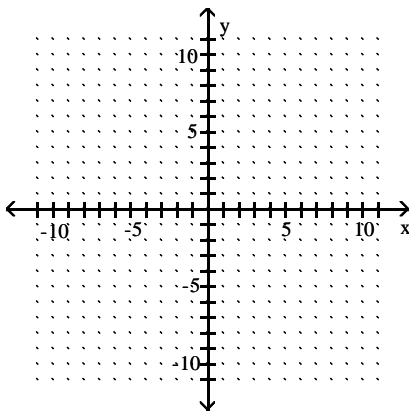

A)

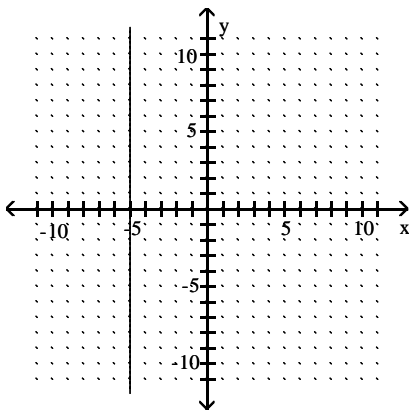

B)

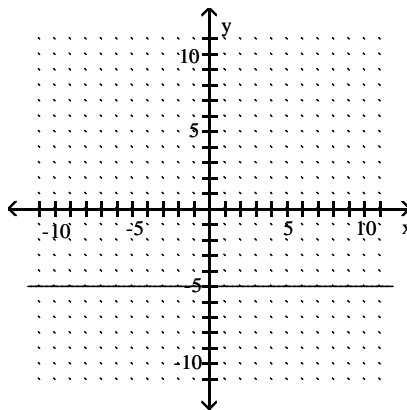

C)

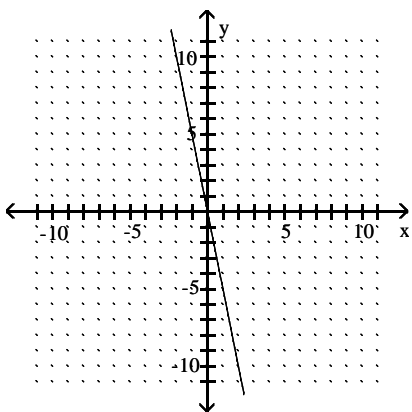

D)

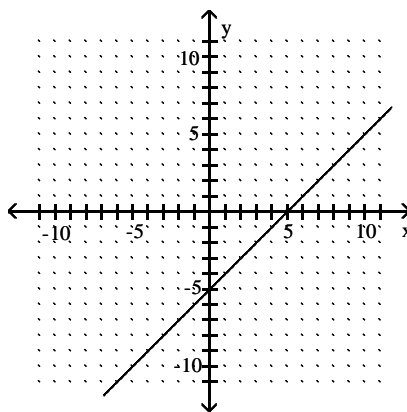

5 Recognize and Use the General Form of a Line's Equation

MULTIPLE CHOICE. Choose the one alternative that best completes the statement or answers the question.

Determine the slope and the y-intercept of the graph of the equation.

1) $y - 8 = 0$

A) $m = 0; (0, 8)$

B) $m = 8; (0, 0)$

C) $m = 1; (0, 8)$

D) $m = 0; \text{no } y\text{-intercept}$

2) $x + y - 2 = 0$

A) $m = -1; (0, 2)$

B) $m = 1; (0, 2)$

C) $m = 0; (0, 2)$

D) $m = -1; (0, -2)$

3) $6x + y + 11 = 0$

A) $m = -6; (0, -11)$

B) $m = -\frac{1}{6}; \left(0, -\frac{11}{6}\right)$

C) $m = 6; (0, -11)$

D) $m = -\frac{6}{11}; \left(0, -\frac{1}{11}\right)$

4) $7x - 10y - 70 = 0$

A) $m = \frac{7}{10}; (0, -7)$

B) $m = -\frac{7}{10}; (0, 7)$

C) $m = \frac{10}{7}; (0, 10)$

D) $m = 7; (0, 70)$

5) $x + 6y - 1 = 0$

A) $m = -\frac{1}{6}; \left(0, \frac{1}{6}\right)$

B) $m = 1; (0, 1)$

C) $m = \frac{1}{6}; \left(0, \frac{1}{6}\right)$

D) $m = -6; (0, 6)$

6) $-x + 11y - 33 = 0$

A) $m = \frac{1}{11}; (0, 3)$

B) $m = -\frac{1}{11}; (0, 3)$

C) $m = -1; (0, 33)$

D) $m = 11; (0, -33)$

Graph the equation.

7) $2x + 3y - 10 = 0$

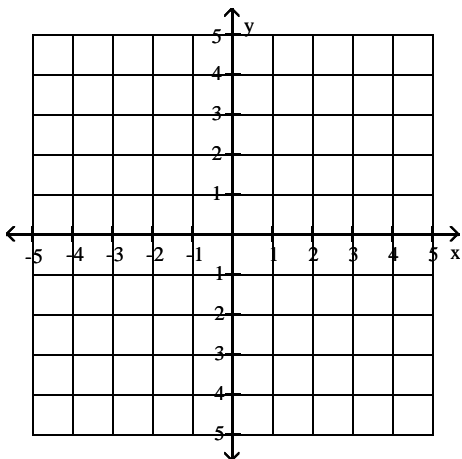

A)

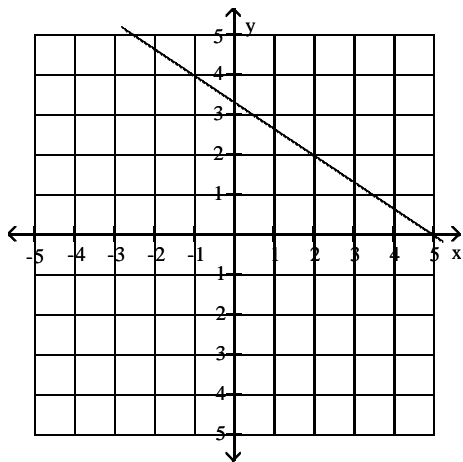

B)

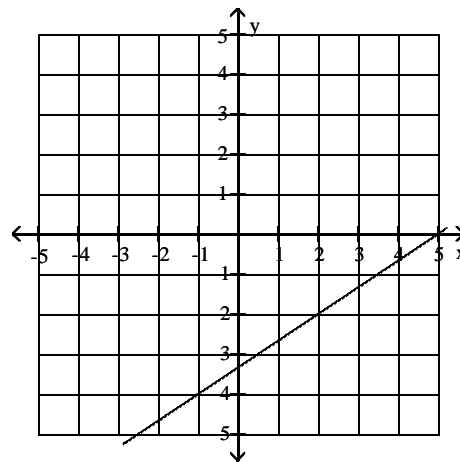

C)

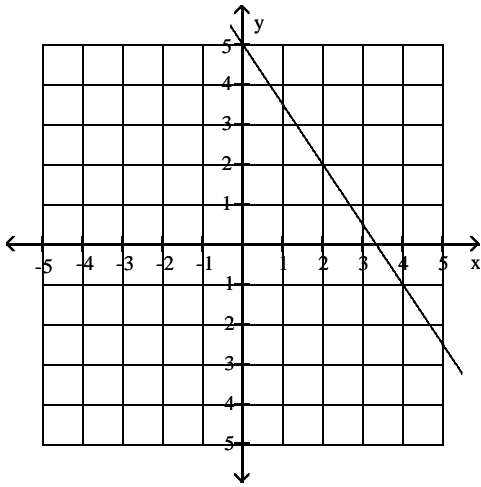

D)

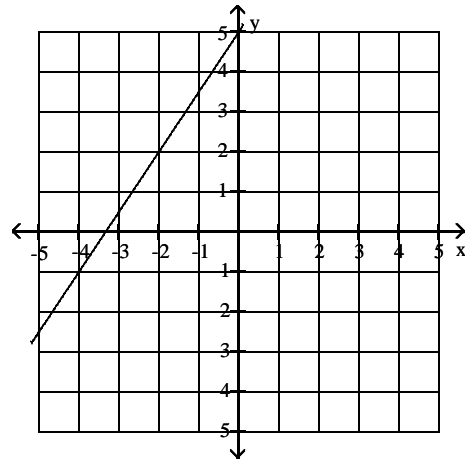

8) $3x - 4y + 7 = 0$

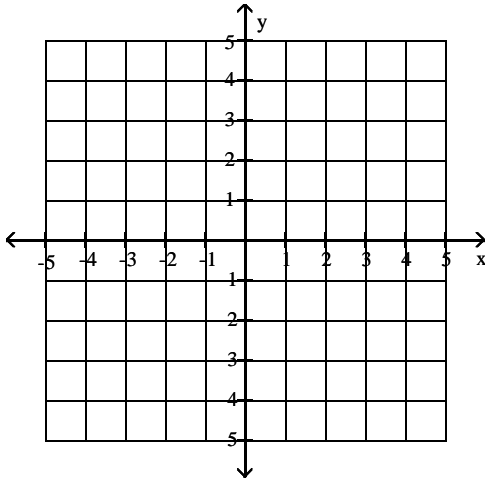

A)

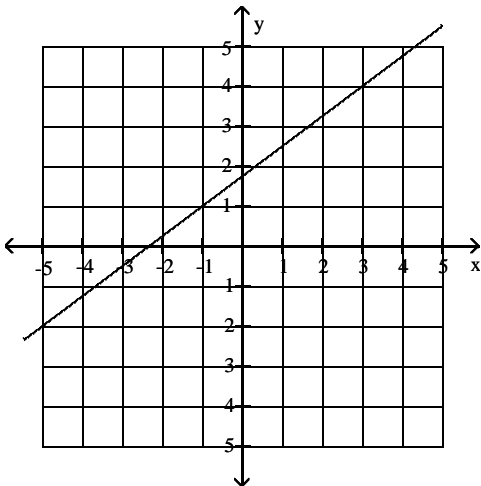

B)

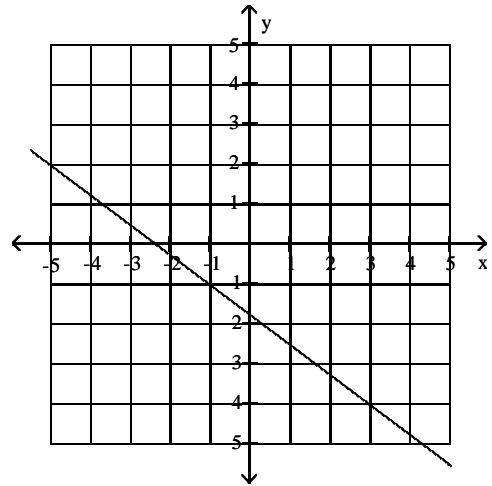

C)

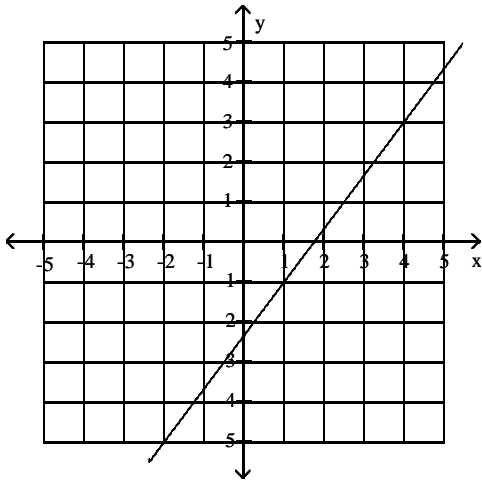

D)

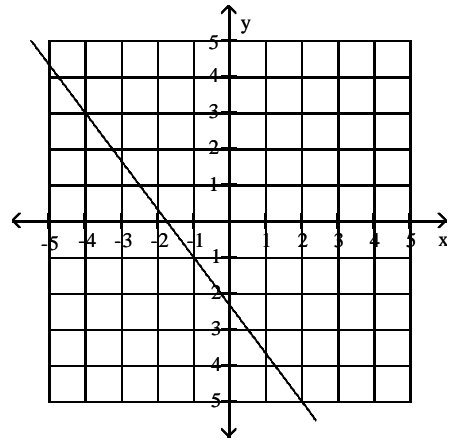

9) $3x - 4y + 14 = 0$

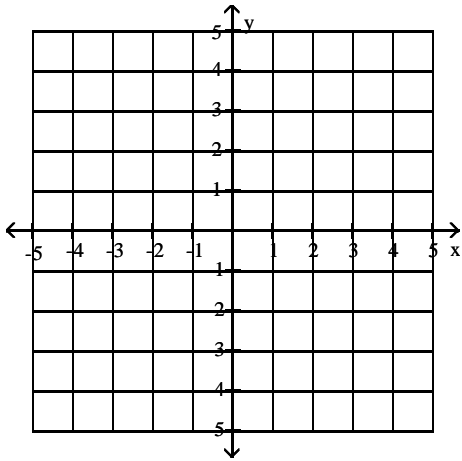

A)

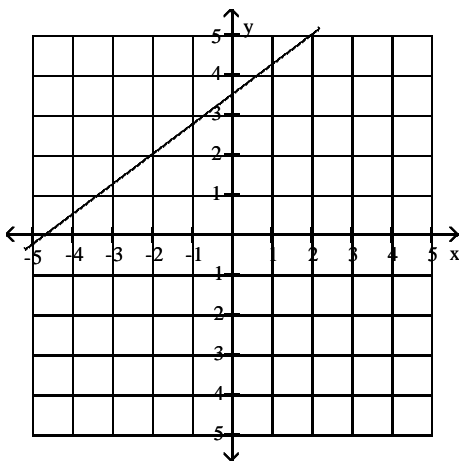

B)

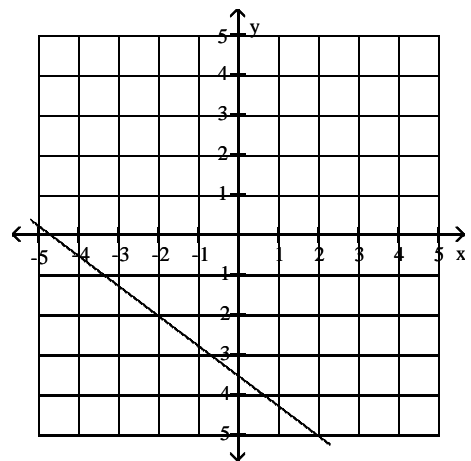

C)

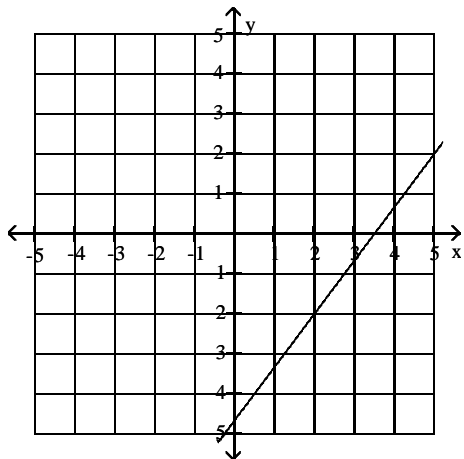

D)

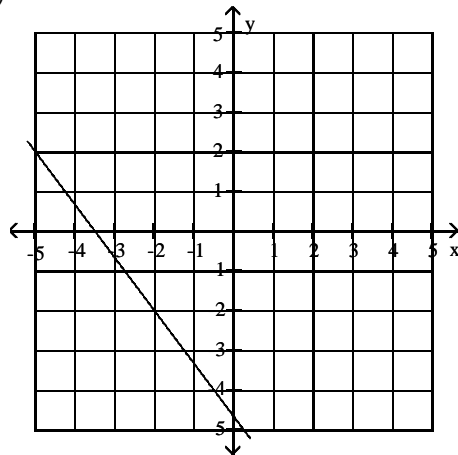

10) $-4y + 3x + 3 = 0$

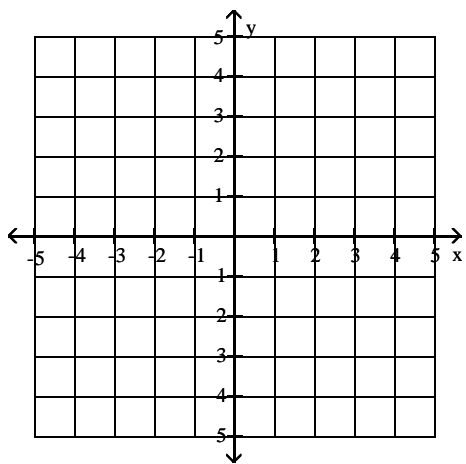

A)

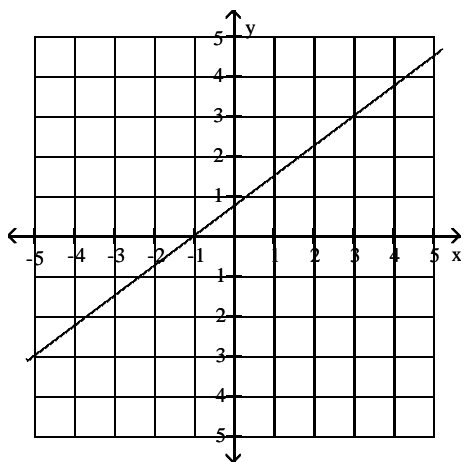

B)

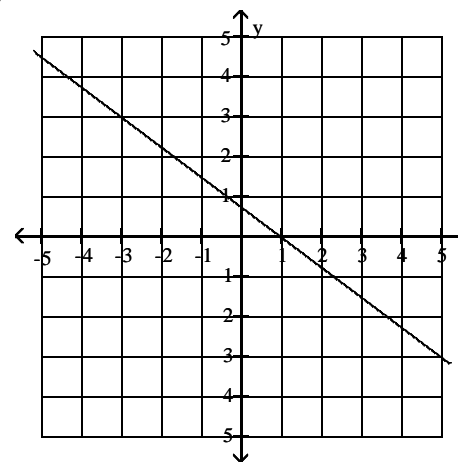

C)

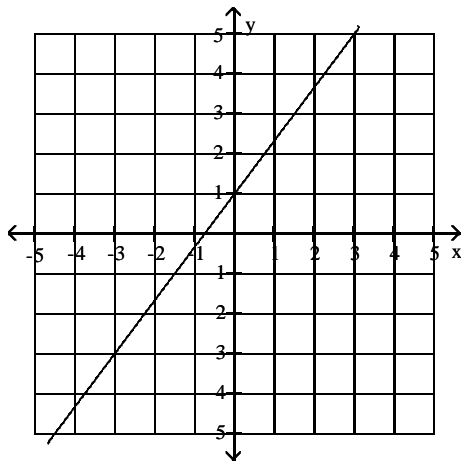

D)

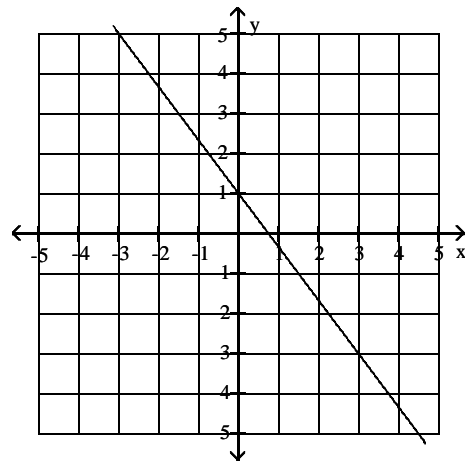

6 Use Intercepts to Graph the General Form of a Line's Equation

MULTIPLE CHOICE. Choose the one alternative that best completes the statement or answers the question.

Graph the linear function by plotting the x- and y-intercepts.

1) $-\frac{1}{2}x + y - 4 = 0$

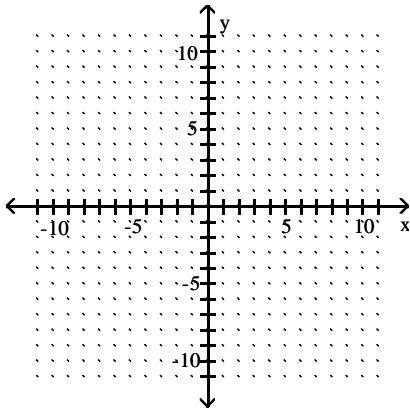

A) intercepts: (0, 4), (-8, 0)

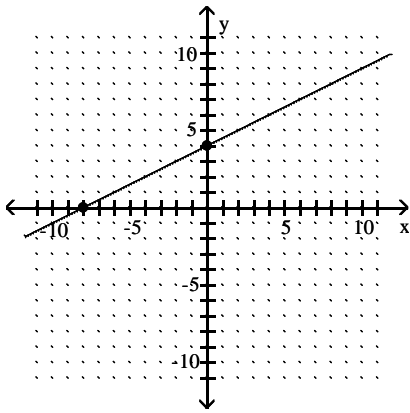

B) intercepts: (0, 4), (8, 0)

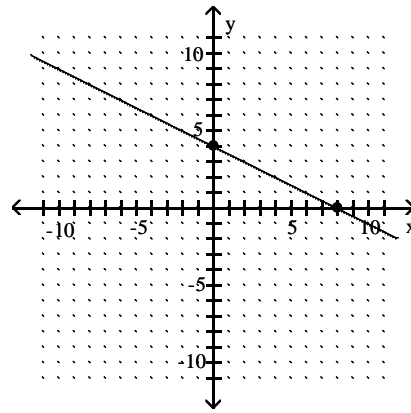

C) intercepts: (0, 4), (-4, 0)

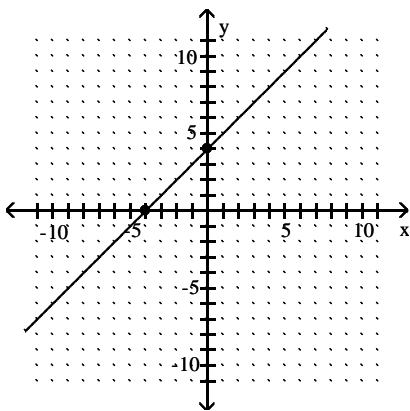

D) intercepts: (0, -8), (8, 0)

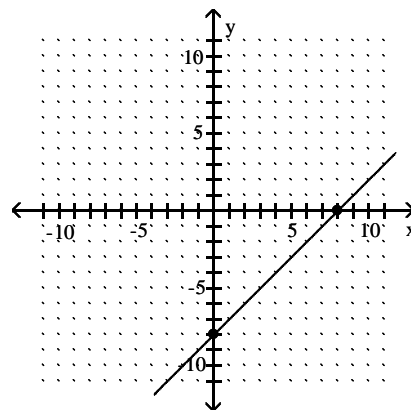

$$2) \frac{1}{3}x + y - 2 = 0$$

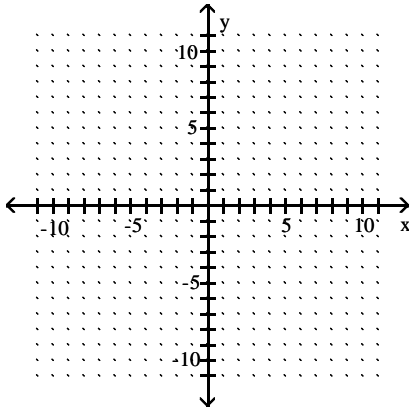

A) intercepts: (0, 2), (6, 0)

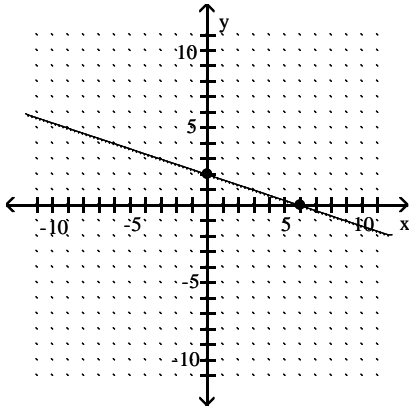

B) intercepts: (0, 2), (-6, 0)

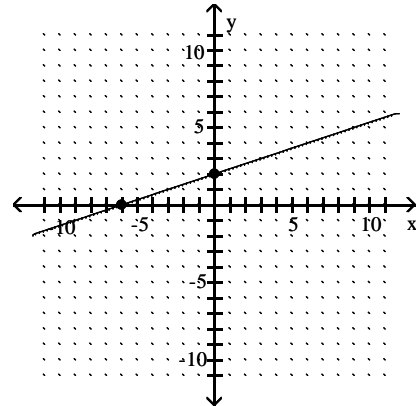

C) intercepts: (0, 2), (-2, 0)

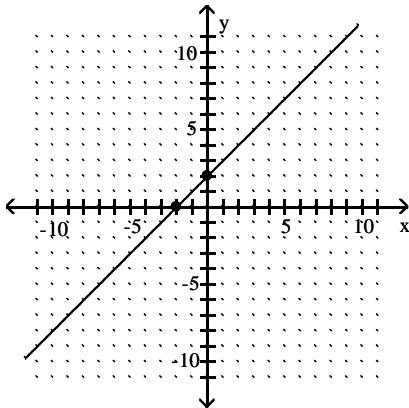

D) intercepts: (0, -6), (6, 0)

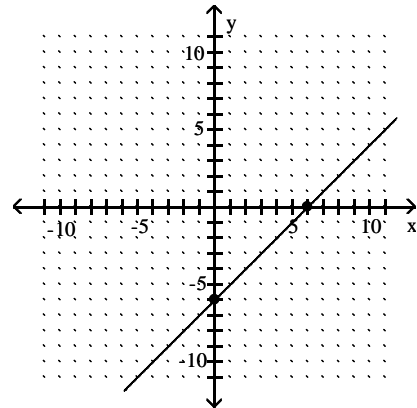

3) $-4x - 24y - 24 = 0$

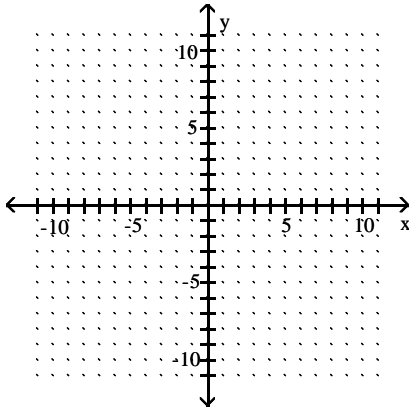

A) intercepts: $(0, -1), (-6, 0)$

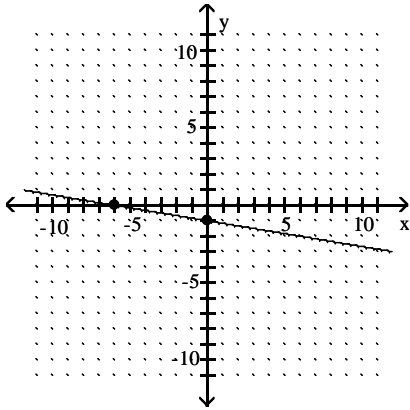

B) intercepts: $(0, -1), (6, 0)$

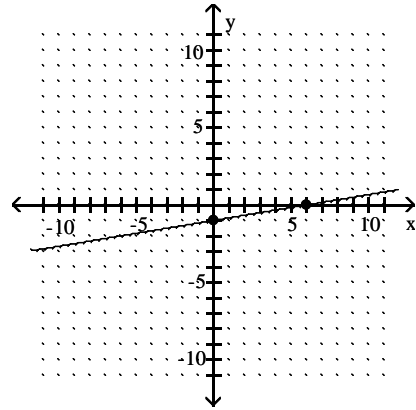

C) intercepts: $(0, -6), (-1, 0)$

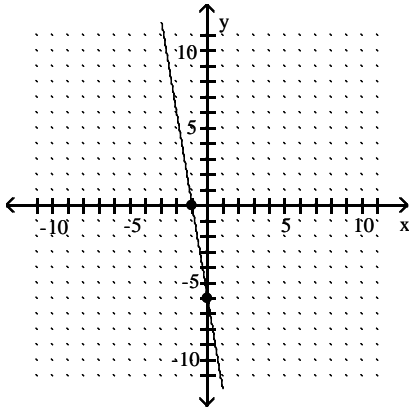

D) intercepts: $(0, 6), (1, 0)$

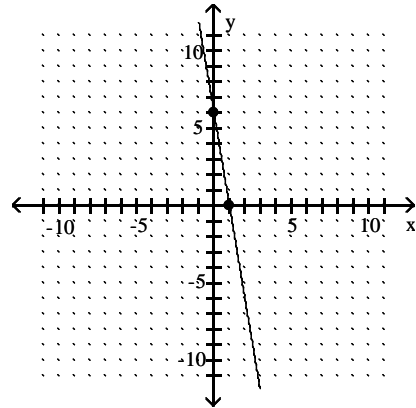

4) $3x - 6y - 18 = 0$

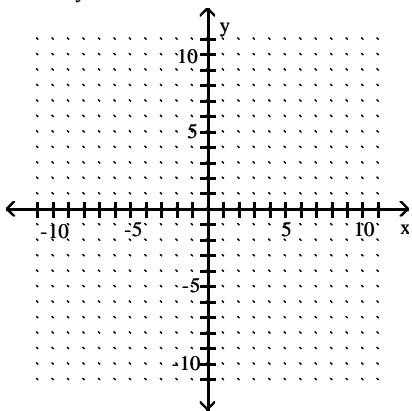

A) intercepts: $(0, -3), (6, 0)$

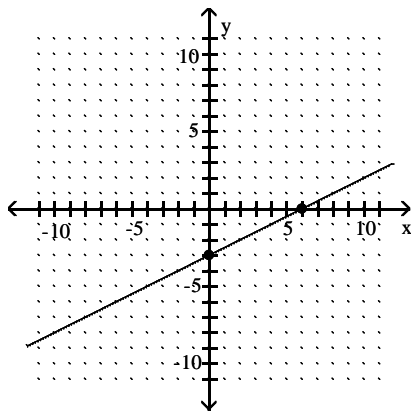

B) intercepts: $(0, -3), (-6, 0)$

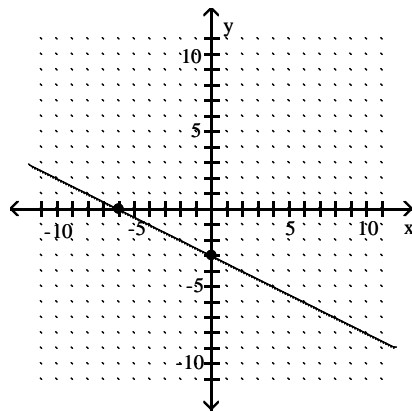

C) intercepts: $(0, 6), (-3, 0)$

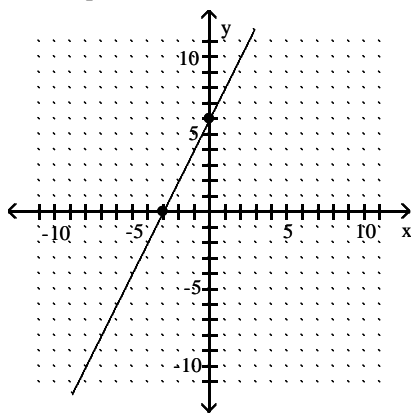

D) intercepts: $(0, -6), (3, 0)$

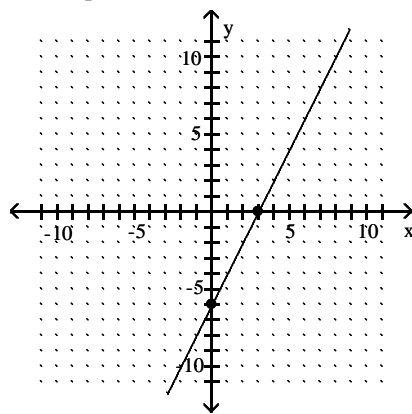

5) $20x + 50y - 100 = 0$

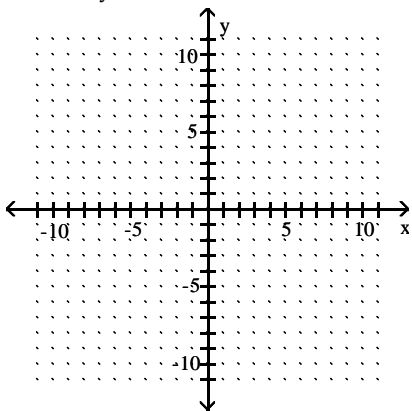

A) intercepts: $(0, 2), (5, 0)$

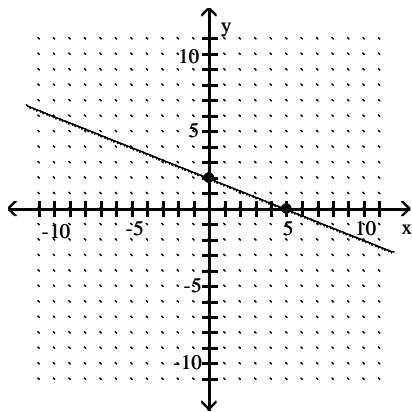

B) intercepts: $(0, -2), (-5, 0)$

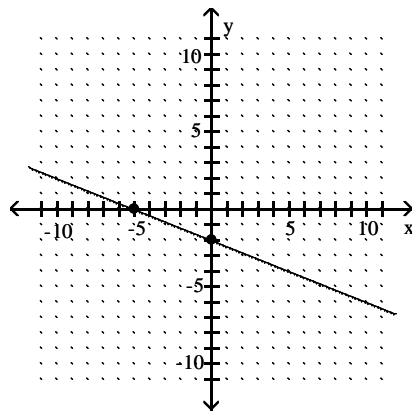

C) intercepts: $(0, 2), (-5, 0)$

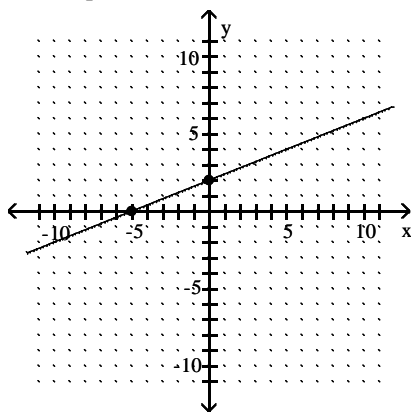

D) intercepts: $(0, -2), (5, 0)$

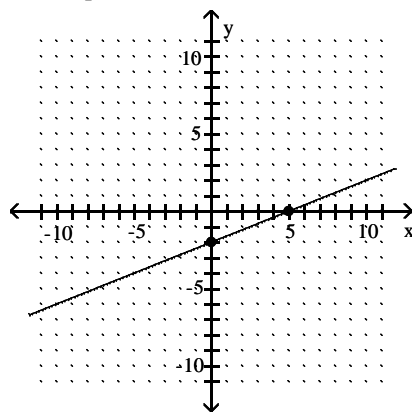

7 Model Data with Linear Functions and Make Predictions

MULTIPLE CHOICE. Choose the one alternative that best completes the statement or answers the question.

Solve.

- 1) A school has just purchased new computer equipment for \$17,000.00. The graph shows the depreciation of the equipment over 5 years. The point (0, 17,000) represents the purchase price and the point (5, 0) represents when the equipment will be replaced. Write a linear equation in slope-intercept form that models the value of the equipment, y , x years after purchase. Use the model to predict the value of the equipment after 1 years?

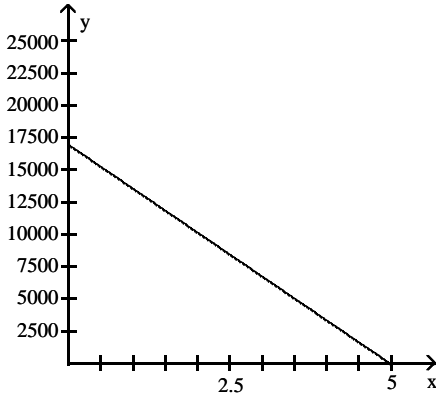

- A) $y = -3400x + 17,000$;
value after 1 years is \$13,600.00;
- B) $y = 17,000x + 5$;
value after 1 years is \$13,600.00
- C) $y = 3400x - 17,000$;
value after 1 years is \$13,600.00
- D) $y = -17,000x + 17,000$;
value after 1 years is \$0.00
- 2) The average value of a certain type of automobile was \$14,280 in 1992 and depreciated to \$5460 in 1997. Let y be the average value of the automobile in the year x , where $x = 0$ represents 1992. Write a linear equation that models the value of the automobile in terms of the year x .
- A) $y = -1764x + 14,280$
- B) $y = -1764x + 5460$
- C) $y = -1764x - 3360$
- D) $y = -\frac{1}{1764}x - 5460$
- 3) An investment is worth \$3329 in 1994. By 1997 it has grown to \$4934. Let y be the value of the investment in the year x , where $x = 0$ represents 1994. Write a linear equation that models the value of the investment in the year x .
- A) $y = 535x + 3329$
- B) $y = \frac{1}{535}x + 3329$
- C) $y = -535x + 6539$
- D) $y = -535x + 3329$
- 4) A faucet is used to add water to a large bottle that already contained some water. After it has been filling for 5 seconds, the gauge on the bottle indicates that it contains 13 ounces of water. After it has been filling for 13 seconds, the gauge indicates the bottle contains 29 ounces of water. Let y be the amount of water in the bottle x seconds after the faucet was turned on. Write a linear equation that models the amount of water in the bottle in terms of x .
- A) $y = 2x + 3$
- B) $y = \frac{1}{2}x + \frac{21}{2}$
- C) $y = -2x + 23$
- D) $y = 2x + 16$

5) When making a telephone call using a calling card, a call lasting 6 minutes cost \$1.65. A call lasting 15 minutes cost \$3.45. Let y be the cost of making a call lasting x minutes using a calling card. Write a linear equation that models the cost of a making a call lasting x minutes.

A) $y = 0.2x + 0.45$

B) $y = 5x - \frac{567}{20}$

C) $y = -0.2x + 2.85$

D) $y = 0.2x - 11.55$

6) A vendor has learned that, by pricing pretzels at \$1.00, sales will reach 92 pretzels per day. Raising the price to \$1.50 will cause the sales to fall to 72 pretzels per day. Let y be the number of pretzels the vendor sells at x dollars each. Write a linear equation that models the number of pretzels sold per day when the price is x dollars each.

A) $y = -40x + 132$

B) $y = -\frac{1}{40}x + \frac{3679}{40}$

C) $y = 40x + 52$

D) $y = -40x - 132$

7) The average value of a certain type of automobile was \$13,320 in 1995 and depreciated to \$4020 in 2000. Let y be the average value of the automobile in the year x , where $x = 0$ represents 1995. Write a linear equation that models the value of the automobile in terms of the year x .

A) $y = -1860x + 13,320$

B) $y = -1860x + 4020$

C) $y = -1860x - 5280$

D) $y = -\frac{1}{1860}x - 4020$

8) An investment is worth \$2882 in 1995. By 1998 it has grown to \$4460. Let y be the value of the investment in the year x , where $x = 0$ represents 1995. Write a linear equation that models the value of the investment in the year x .

A) $y = 526x + 2882$

B) $y = \frac{1}{526}x + 2882$

C) $y = -526x + 6038$

D) $y = -526x + 2882$

9) When making a telephone call using a calling card, a call lasting 4 minutes cost \$2.00. A call lasting 14 minutes cost \$6.00. Let y be the cost of making a call lasting x minutes using a calling card. Write a linear equation that models the cost of making a call lasting x minutes.

A) $y = 0.4x + 0.4$

B) $y = \frac{5}{2}x - 8$

C) $y = -0.4x + 3.6$

D) $y = 0.4x - 8$

10) A vendor has learned that, by pricing pretzels at \$1.50, sales will reach 113 pretzels per day. Raising the price to \$2.00 will cause the sales to fall to 89 pretzels per day. Let y be the number of pretzels the vendor sells at x dollars each. Write a linear equation that models the number of pretzels sold per day when the price is x dollars each.

A) $y = -48x + 185$

B) $y = -\frac{1}{48}x + \frac{3615}{32}$

C) $y = 48x + 41$

D) $y = -48x - 185$

2.4 More on Slope

1 Find Slopes and Equations of Parallel and Perpendicular Lines

MULTIPLE CHOICE. Choose the one alternative that best completes the statement or answers the question.

Find an equation for the line with the given properties.

- 1) The solid line L contains the point $(-1, 4)$ and is perpendicular to the dotted line whose equation is $y = 2x$. Give the equation of line L in slope-intercept form.

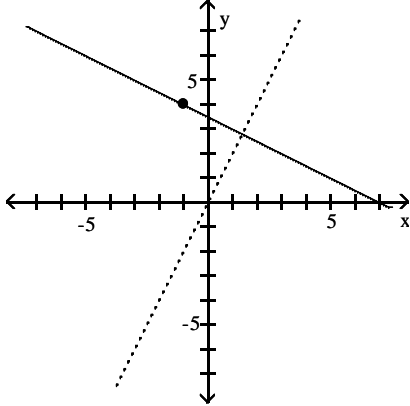

A) $y = -\frac{1}{2}x + \frac{7}{2}$

B) $y - 4 = -\frac{1}{2}(x + 1)$

C) $y = \frac{1}{2}x + \frac{7}{2}$

D) $y - 4 = 2(x + 1)$

- 2) The solid line L contains the point $(3, 2)$ and is parallel to the dotted line whose equation is $y = 2x$. Give the equation for the line L in slope-intercept form.

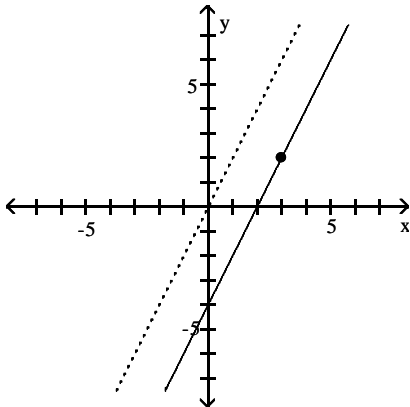

A) $y = 2x - 4$

B) $y = 2x - 1$

C) $y - 2 = 2(x - 3)$

D) $y = 2x + b$

Use the given conditions to write an equation for the line in the indicated form.

- 3) Passing through $(4, 3)$ and parallel to the line whose equation is $y = 2x - 6$;
point-slope form

A) $y - 3 = 2(x - 4)$

B) $y - 4 = 2(x - 3)$

C) $y - 3 = x - 4$

D) $y = 2x$

- 4) Passing through $(5, 3)$ and perpendicular to the line whose equation is $y = 2x + 7$;
point-slope form

A) $y - 3 = -\frac{1}{2}(x - 5)$

B) $y - 3 = \frac{1}{2}(x + 5)$

C) $y - 5 = \frac{1}{2}(x - 3)$

D) $y = -2x - 11$

5) Passing through (2, 3) and parallel to the line whose equation is $y = -2x + 3$;
point-slope form

A) $y - 3 = -2(x - 2)$

B) $y - 2 = -2(x - 3)$

C) $y - 3 = x - 2$

D) $y = 2x$

6) Passing through (4, -4) and parallel to the line whose equation is $y = -2x + 5$;
slope-intercept form

A) $y = -2x + 4$

B) $y = 2x - 4$

C) $y = -2x - 4$

D) $y = -\frac{1}{2}x - 2$

7) Passing through (2, 5) and perpendicular to the line whose equation is $y = \frac{1}{6}x + 8$;

slope-intercept form

A) $y = -6x + 17$

B) $y = 6x - 17$

C) $y = -6x - 17$

D) $y = -\frac{1}{6}x - \frac{17}{6}$

8) Passing through (2, 3) and parallel to the line whose equation is $y = -\frac{1}{9}x + 9$;

slope-intercept form

A) $y = -\frac{1}{9}x + \frac{29}{9}$

B) $y = \frac{1}{9}x - \frac{29}{9}$

C) $y = -\frac{1}{9}x - \frac{29}{9}$

D) $y = -9x - 29$

9) Passing through (4, 4) and parallel to the line whose equation is $2x + y - 7 = 0$;
slope-intercept form

A) $y = -2x + 12$

B) $y = 2x - 12$

C) $y = -2x - 12$

D) $y = -\frac{1}{2}x - 6$

10) Passing through (3, 2) and perpendicular to the line whose equation is $-4x + y - 8 = 0$;
slope-intercept form

A) $y = -\frac{1}{4}x + \frac{11}{4}$

B) $y = \frac{1}{4}x - \frac{11}{4}$

C) $y = -\frac{1}{4}x - \frac{11}{4}$

D) $y = -4x - 11$

2 Interpret Slope as Rate of Change

MULTIPLE CHOICE. Choose the one alternative that best completes the statement or answers the question.

Find the slope then describe what it means in terms of the rate of change of the dependent variable per unit change in the independent variable.

1) The linear function $f(x) = 4.5x + 24$ represents the percentage of people, $f(x)$, who graduated from college x years after 1998.

A) $m = 4.5$; the percentage of people graduating from college has increased at a rate of 4.5% per year after 1998.

B) $m = -4.5$; the percentage of people graduating from college has decreased at a rate of 4.5% per year after 1998.

C) $m = 24$; the percentage of people graduating from college has increased at a rate of 24% per year after 1998.

D) $m = 4.5$; the percentage of people graduating from college has decreased at a rate of 4.5% per year after 1998.

- 2) The linear function $f(x) = -8.7x + 38$ models the percentage of people, $f(x)$, who eat at fast food restaurants each week x years after 1998.
- A) $m = -8.7$; the percentage of people eating at fast food restaurants each week has decreased at a rate of -8.7% per year after 1998.
 - B) $m = 8.7$; the percentage of people eating at fast food restaurants each week has increased at a rate of -8.7% per year after 1998.
 - C) $m = 38$; the percentage of people eating at fast food restaurants each week has increased at a rate of -8.7% per year after 1998.
 - D) $m = 8.7$; the percentage of people eating at fast food restaurants each week has increased at a rate of 8.7% per year after 1998.

3 Find a Function's Average Rate of Change

MULTIPLE CHOICE. Choose the one alternative that best completes the statement or answers the question.

Find the average rate of change of the function from x_1 to x_2 .

- 1) $f(x) = \sqrt{2x}$ from $x_1 = 2$ to $x_2 = 8$
- A) $\frac{1}{3}$ B) 2 C) 7 D) $-\frac{3}{10}$
- 2) $f(x) = -3x^2 - x$ from $x_1 = 5$ to $x_2 = 6$
- A) -34 B) -2 C) $\frac{1}{2}$ D) $-\frac{1}{6}$
- 3) $f(x) = 5x + 7$ from $x_1 = -1$ to $x_2 = 0$
- A) 5 B) -28 C) $\frac{1}{2}$ D) $-\frac{1}{6}$

Solve the problem.

- 4) From April through December 2000, the stock price of QRS Company had a roller coaster ride. The chart below indicates the price of the stock at the beginning of each month during that period. Find the monthly average rate of change in price between June and September.

| Month | Price |
|-------------------|-------|
| April ($x = 1$) | 114 |
| May | 108 |
| June | 87 |
| July | 100 |
| August | 95 |
| September | 112 |
| October | 93 |
| November | 86 |
| December | 64 |

- A) \$8.33 per month B) $-\$8.33$ per month C) \$12.50 per month D) $-\$12.50$ per month

- 5) Along with incomes, people's charitable contributions have steadily increased over the past few years. The table below shows the average deduction for charitable contributions reported on individual income tax returns for the period 1993 to 1998. Find the average annual increase between 1995 and 1997.

| Year | Charitable Contributions |
|------|--------------------------|
| 1993 | \$1730 |
| 1994 | \$2400 |
| 1995 | \$2470 |
| 1996 | \$2790 |
| 1997 | \$3050 |
| 1998 | \$3200 |

- A) \$290 per year B) \$580 per year C) \$365 per year D) \$325 per year
- 6) A deep sea diving bell is being lowered at a constant rate. After 11 minutes, the bell is at a depth of 300 ft. After 40 minutes the bell is at a depth of 1500 ft. What is the average rate of lowering per minute? Round to the nearest hundredth is needed.
- A) 41.4 ft per minute B) 0.02 ft per minute C) 30.0 ft per minute D) 37.5 ft per minute

2.5 Transformations of Functions

1 Recognize Graphs of Common Functions

MULTIPLE CHOICE. Choose the one alternative that best completes the statement or answers the question.

Use the shape of the graph to name the function.

1)

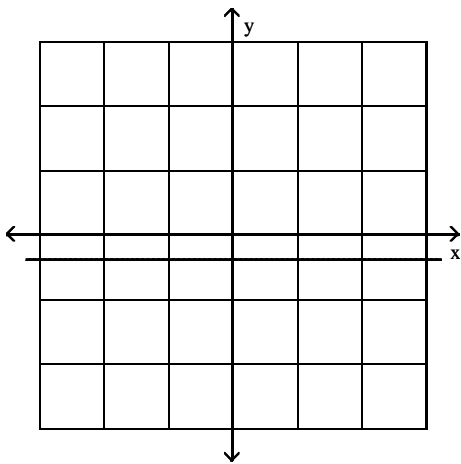

- A) Constant function B) Identity function
- C) Absolute value function D) Standard cubic function

2)

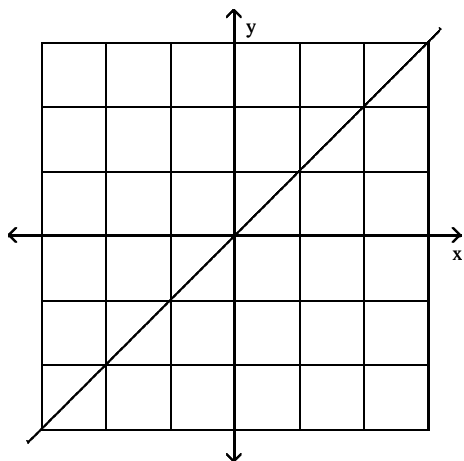

A) Identity function

C) Absolute value function

B) Constant function

D) Square root function

3)

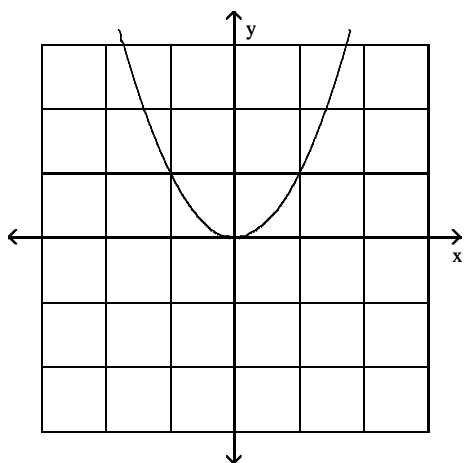

A) Standard quadratic function

C) Standard cubic function

B) Constant function

D) Square root function

4)

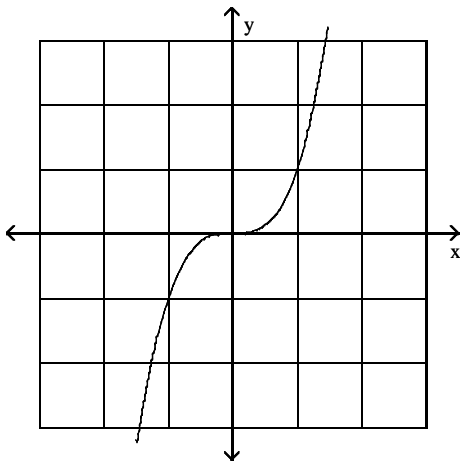

- A) Standard cubic function
- C) Standard quadratic function

- B) Constant function
- D) Square root function

5)

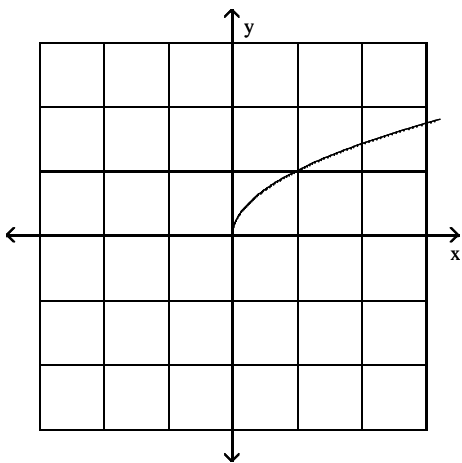

- A) Square root function
- C) Standard quadratic function

- B) Constant function
- D) Standard cubic function

6)

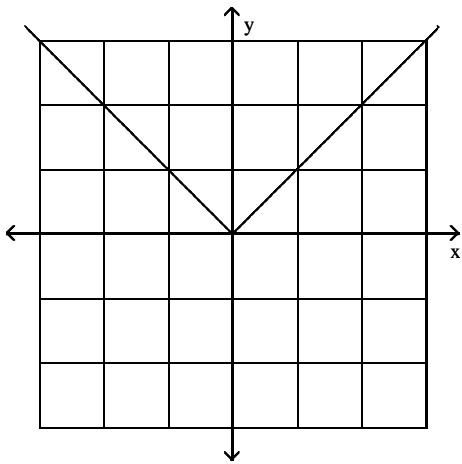

A) Absolute value function

C) Identity function

B) Constant function

D) Standard cubic function

2 Use Vertical Shifts to Graph Functions

MULTIPLE CHOICE. Choose the one alternative that best completes the statement or answers the question.

Begin by graphing the standard quadratic function $f(x) = x^2$. Then use transformations of this graph to graph the given function.

1) $g(x) = x^2 - 2$

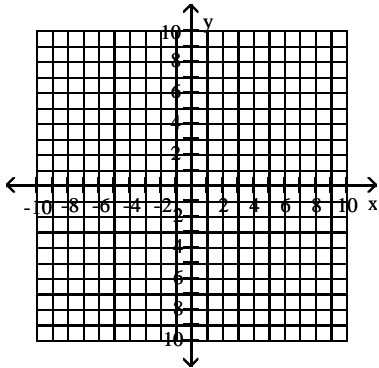

A)

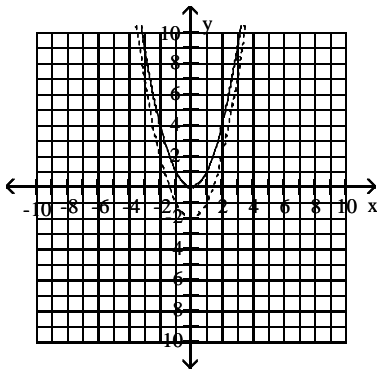

B)

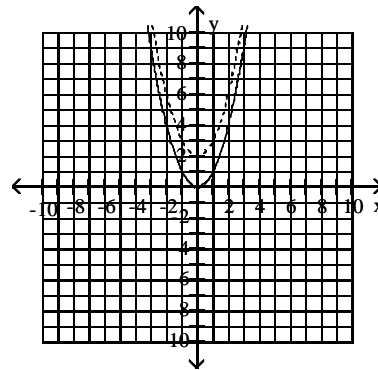

C)

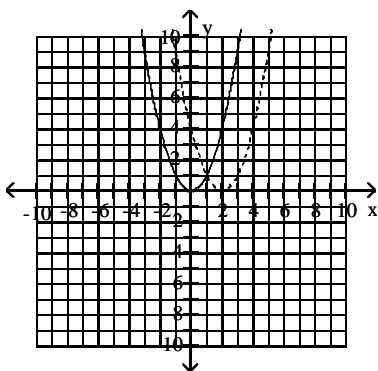

D)

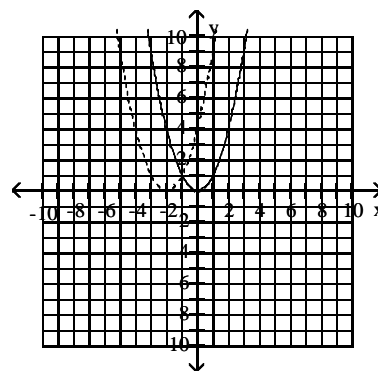

Begin by graphing the standard square root function $f(x) = \sqrt{x}$. Then use transformations of this graph to graph the given function.

2) $g(x) = \sqrt{x} - 1$

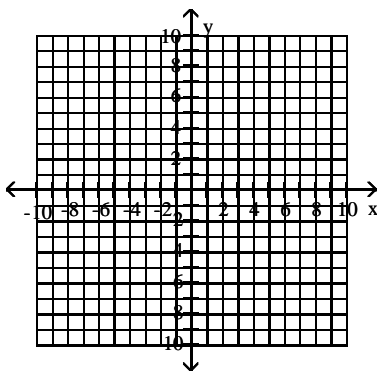

A)

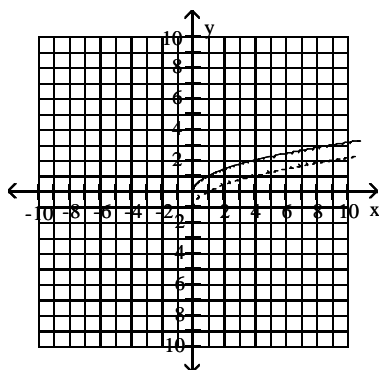

B)

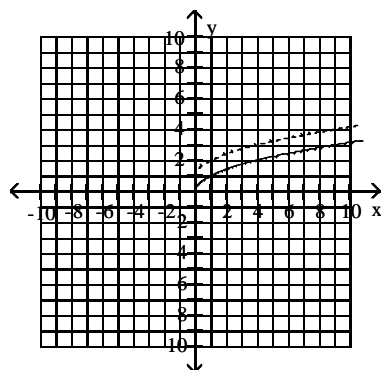

C)

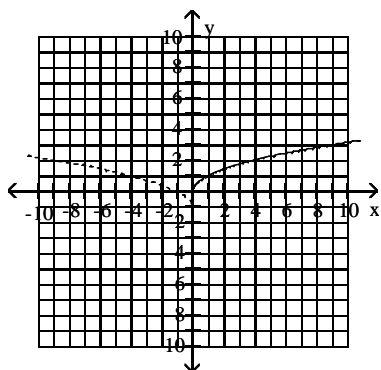

D)

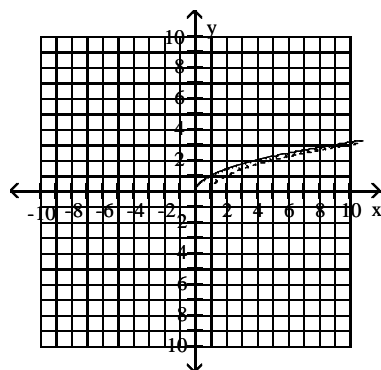

Begin by graphing the standard absolute value function $f(x) = |x|$. Then use transformations of this graph to graph the given function.

3) $g(x) = |x| + 2$

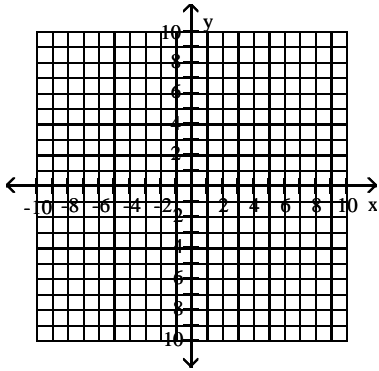

A)

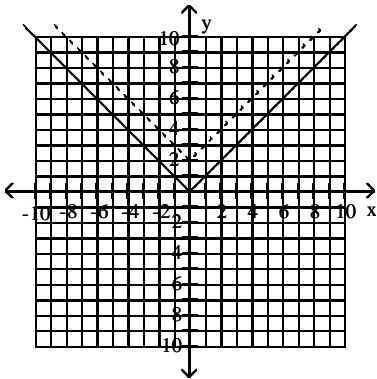

B)

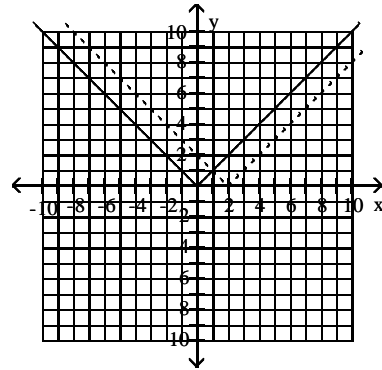

C)

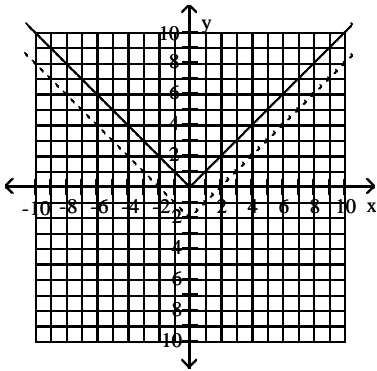

D)

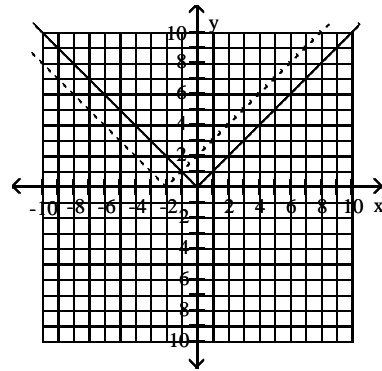

Begin by graphing the standard function $f(x) = x^3$. Then use transformations of this graph to graph the given function.

4) $g(x) = x^3 + 2$

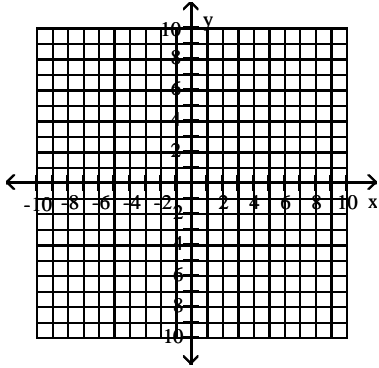

A)

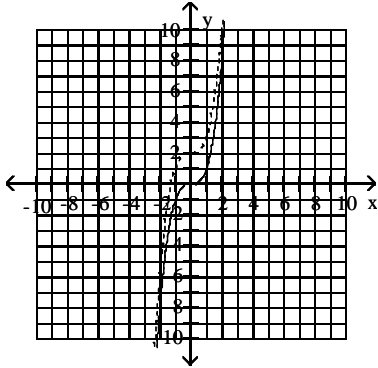

B)

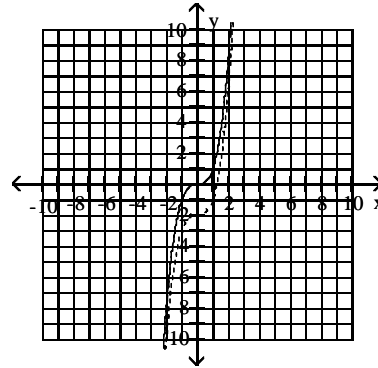

C)

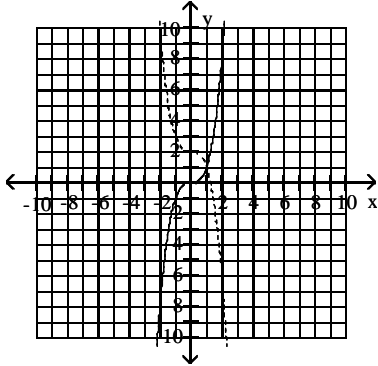

D)

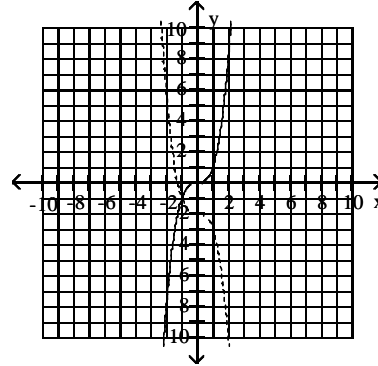

Use the graph of the function f , plotted with a solid line, to sketch the graph of the given function g .

5) $g(x) = f(x) + 2$

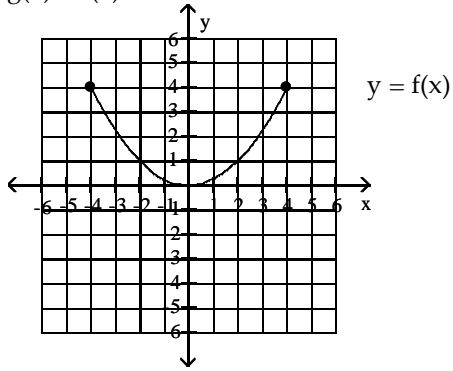

A)

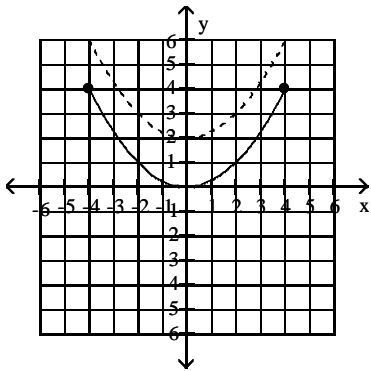

B)

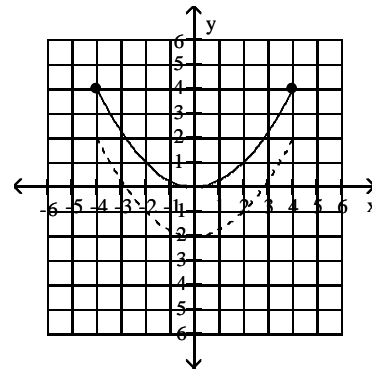

C)

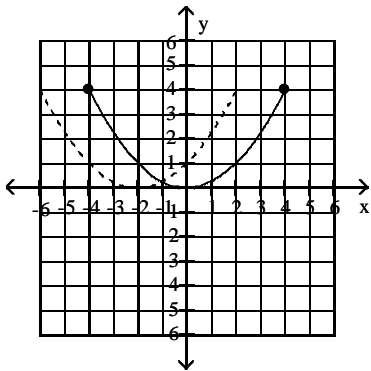

D)

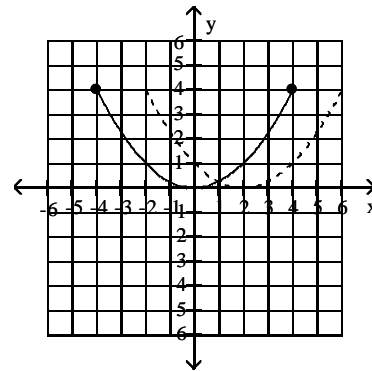

Begin by graphing the standard cube root function $f(x) = \sqrt[3]{x}$. Then use transformations of this graph to graph the given function.

6) $g(x) = \sqrt[3]{x} + 3$

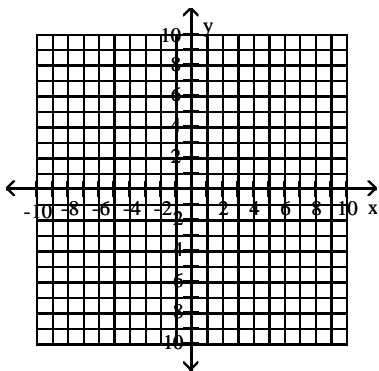

A)

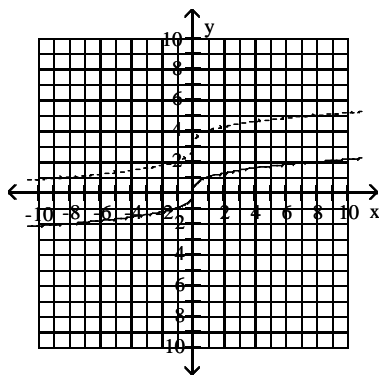

B)

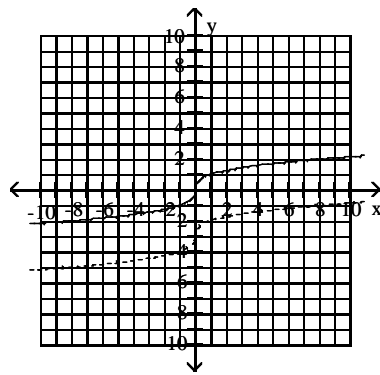

C)

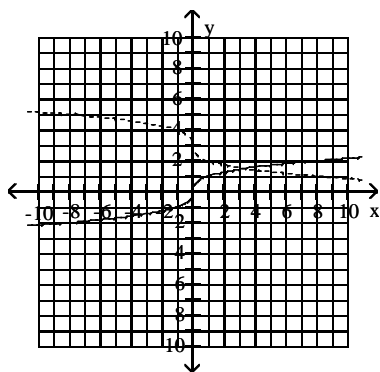

D)

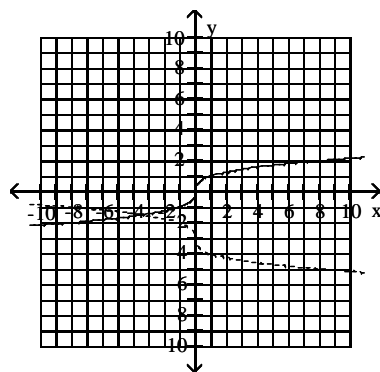

3 Use Horizontal Shifts to Graph Functions

MULTIPLE CHOICE. Choose the one alternative that best completes the statement or answers the question.

Begin by graphing the standard quadratic function $f(x) = x^2$. Then use transformations of this graph to graph the given function.

1) $h(x) = (x - 2)^2$

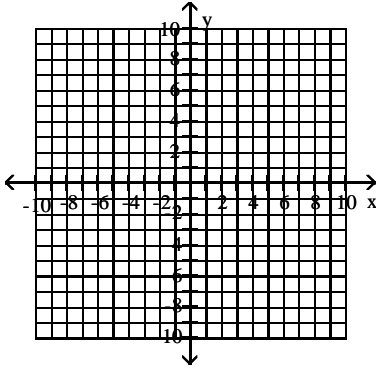

A)

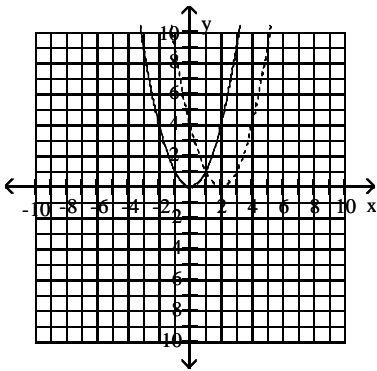

B)

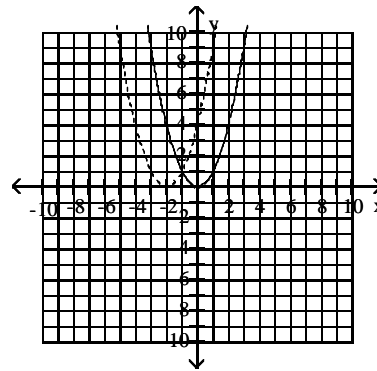

C)

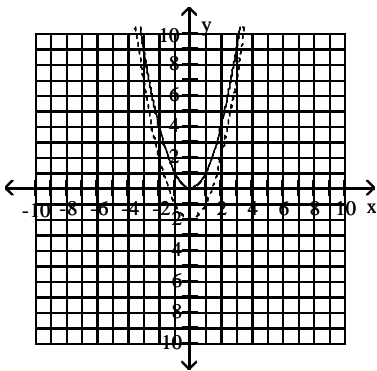

D)

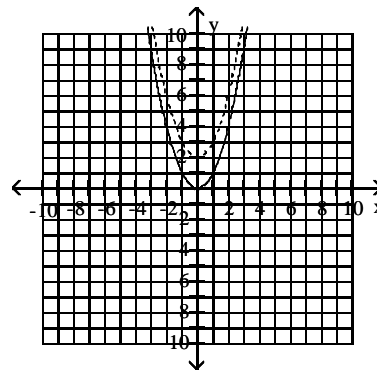

Begin by graphing the standard square root function $f(x) = \sqrt{x}$. Then use transformations of this graph to graph the given function.

2) $h(x) = \sqrt{x + 2}$

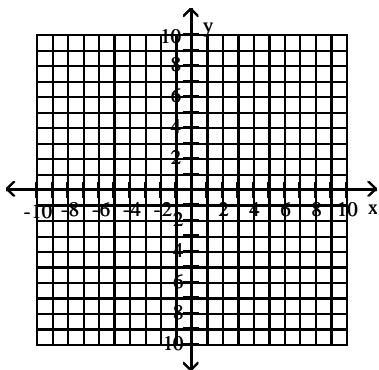

A)

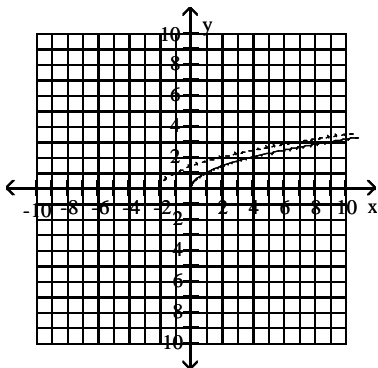

B)

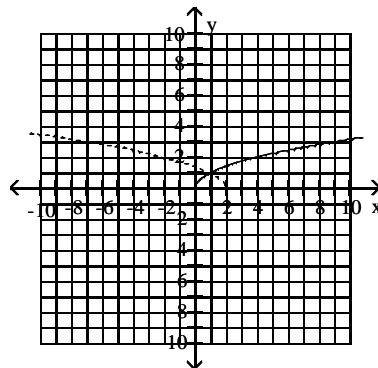

C)

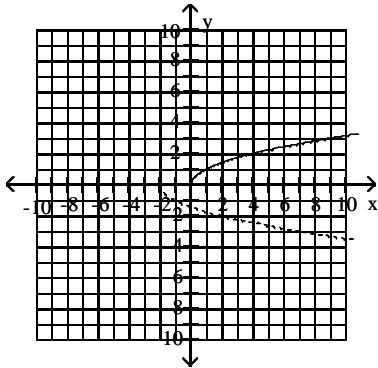

D)

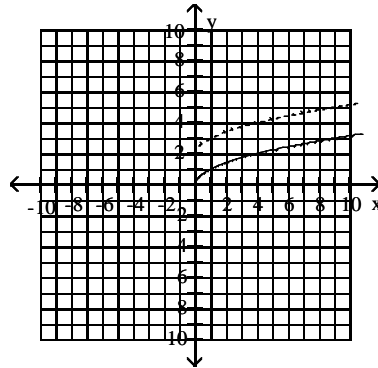

Begin by graphing the standard absolute value function $f(x) = |x|$. Then use transformations of this graph to graph the given function.

3) $h(x) = |x - 3| - 3$

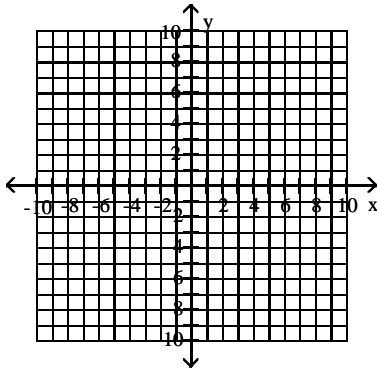

A)

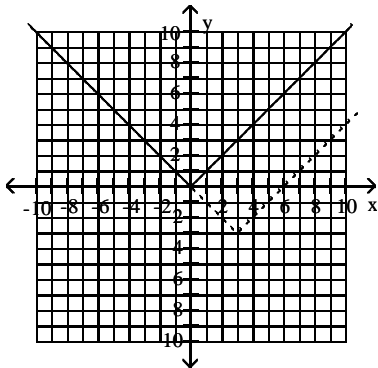

B)

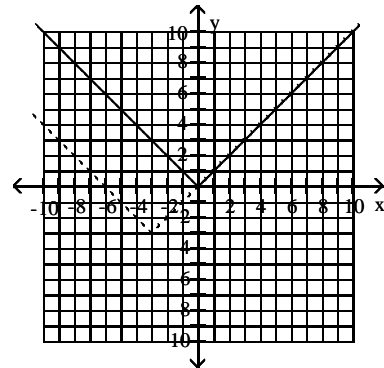

C)

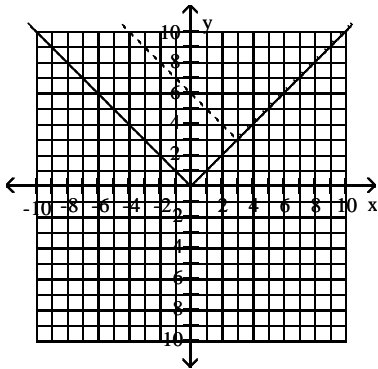

D)

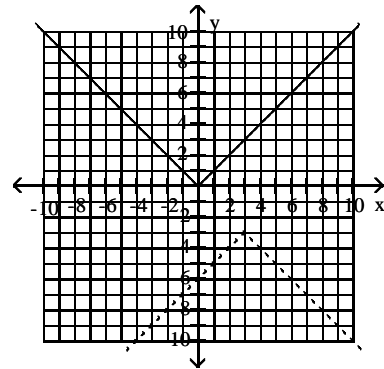

Use the graph of the function f , plotted with a solid line, to sketch the graph of the given function g .

4) $g(x) = |x - 3|$

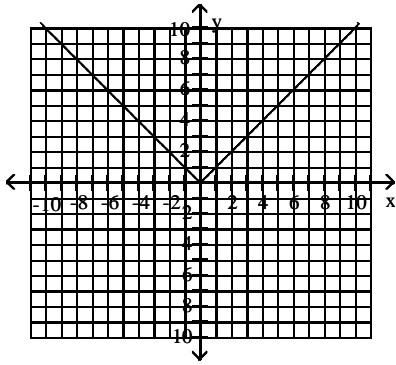

A)

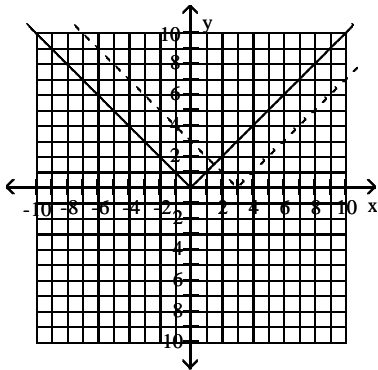

B)

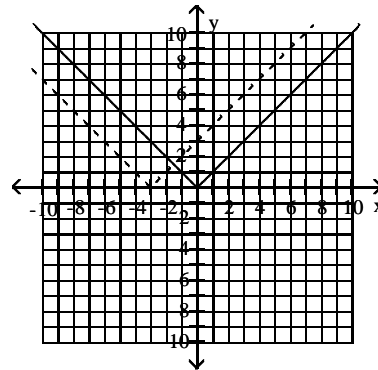

C)

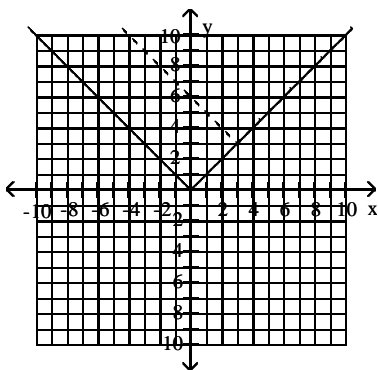

D)

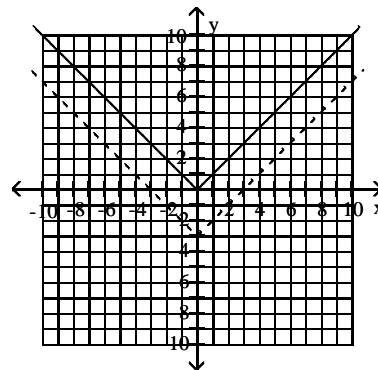

Begin by graphing the standard function $f(x) = x^3$. Then use transformations of this graph to graph the given function.

5) $h(x) = (x - 2)^3$

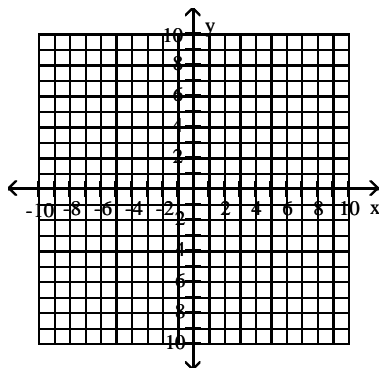

A)

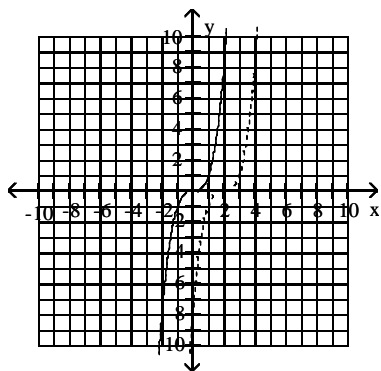

B)

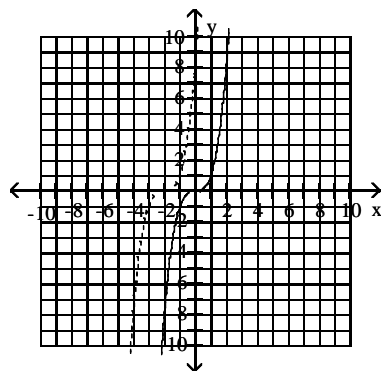

C)

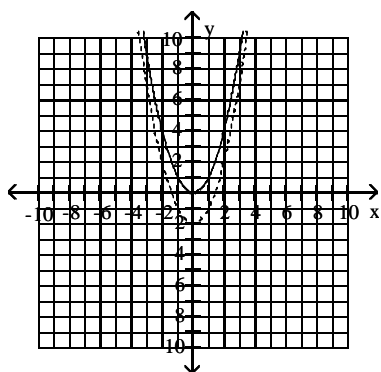

D)

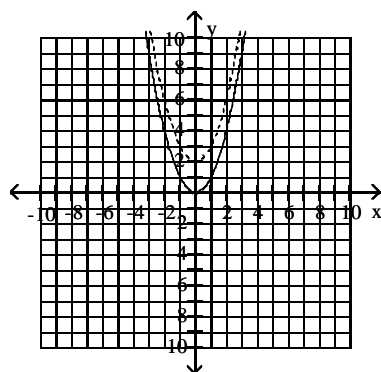

Use the graph of the function f , plotted with a solid line, to sketch the graph of the given function g .

6) $g(x) = f(x - 1)$

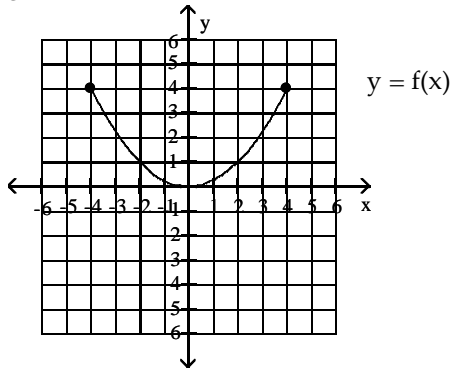

A)

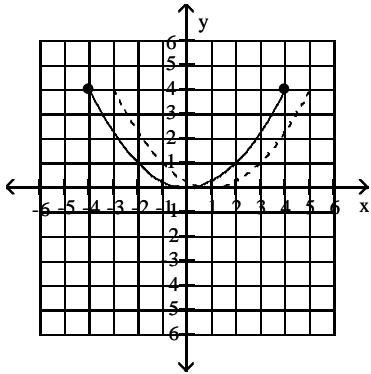

B)

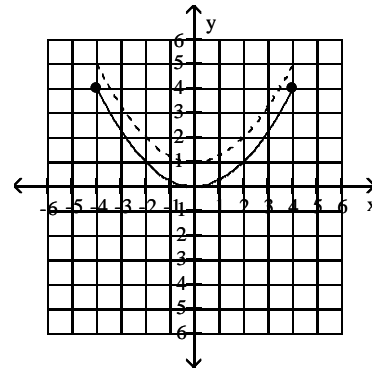

C)

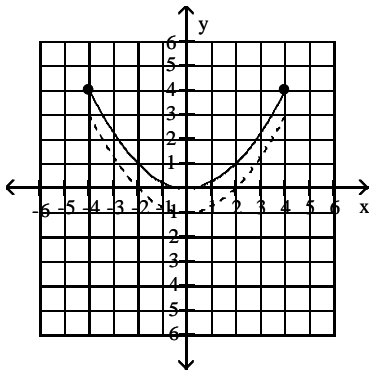

D)

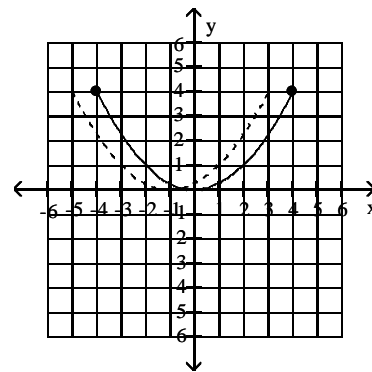

4 Use Reflections to Graph Functions

MULTIPLE CHOICE. Choose the one alternative that best completes the statement or answers the question.

Begin by graphing the standard quadratic function $f(x) = x^2$. Then use transformations of this graph to graph the given function.

1) $h(x) = -(x + 2)^2$

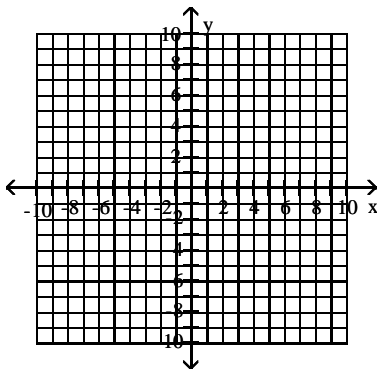

A)

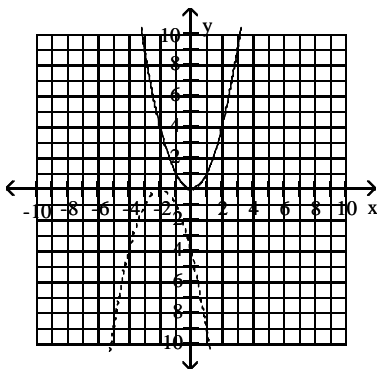

B)

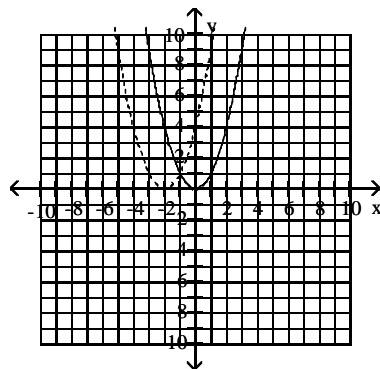

C)

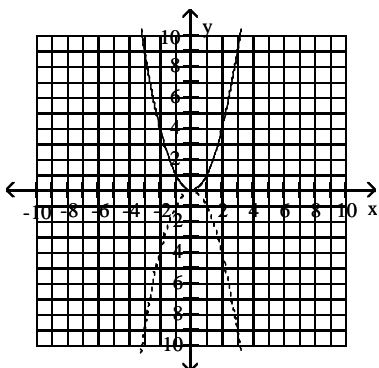

D)

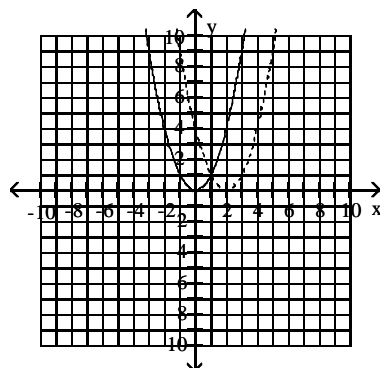

Begin by graphing the standard square root function $f(x) = \sqrt{x}$. Then use transformations of this graph to graph the given function.

2) $g(x) = -\sqrt{x} - 3$

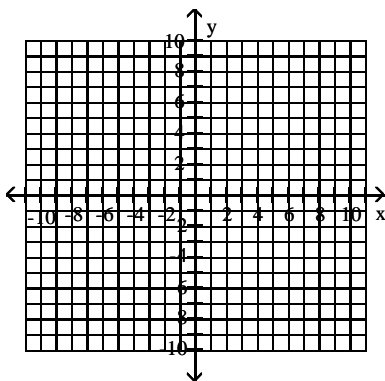

A)

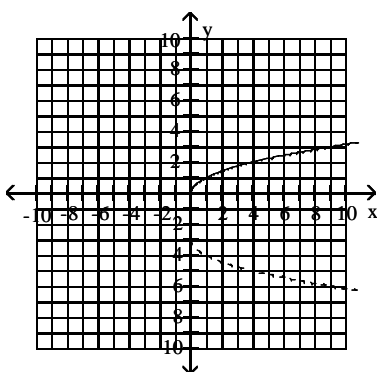

B)

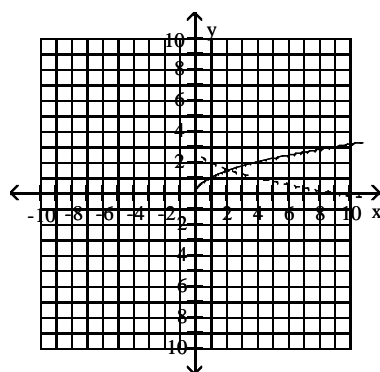

C)

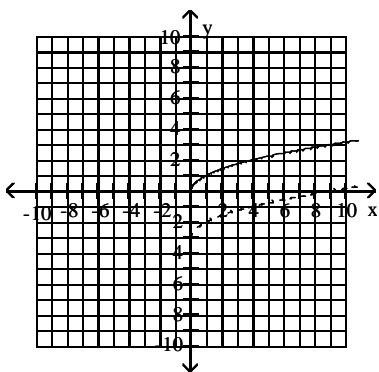

D)

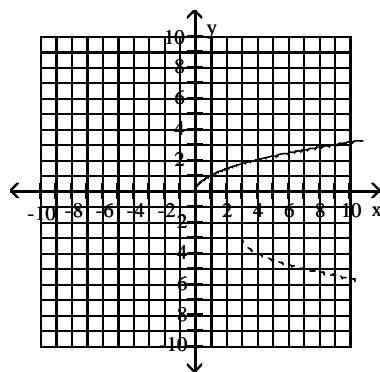

3) $g(x) = \sqrt{-x - 1}$

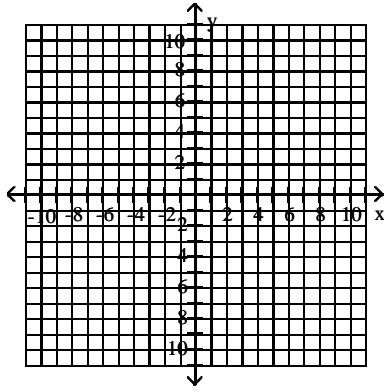

A)

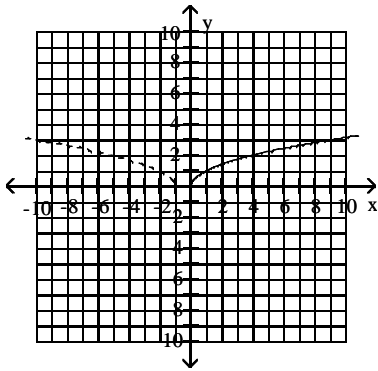

B)

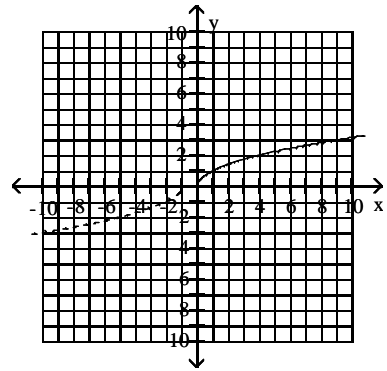

C)

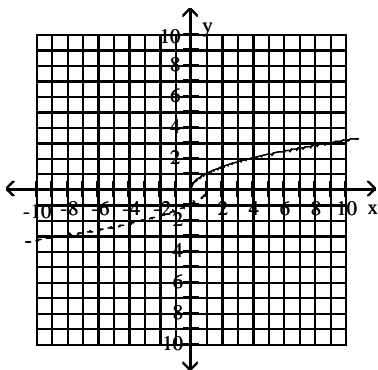

D)

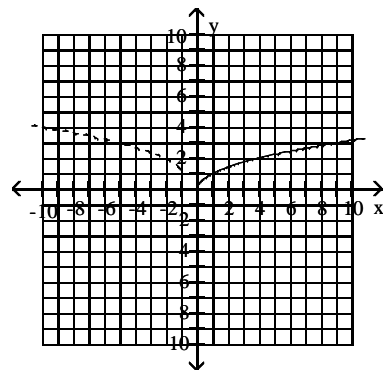

Begin by graphing the standard absolute value function $f(x) = |x|$. Then use transformations of this graph to graph the given function.

4) $h(x) = -|x - 5|$

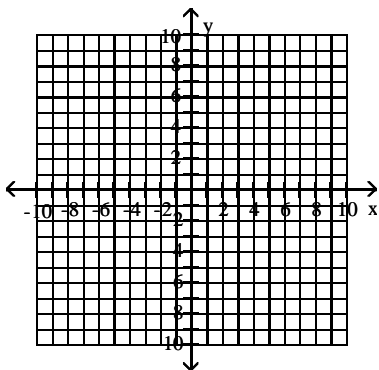

A)

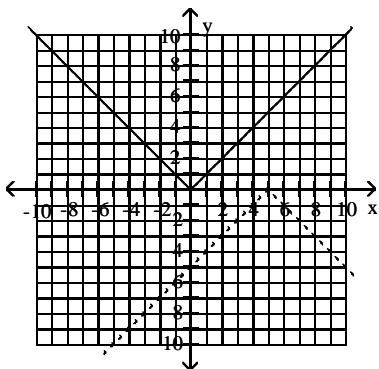

B)

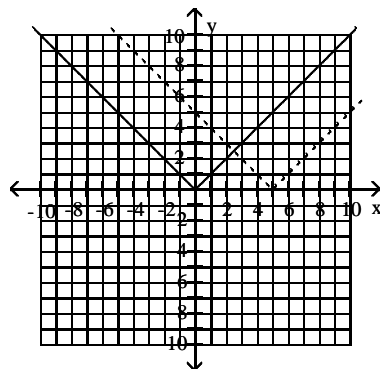

C)

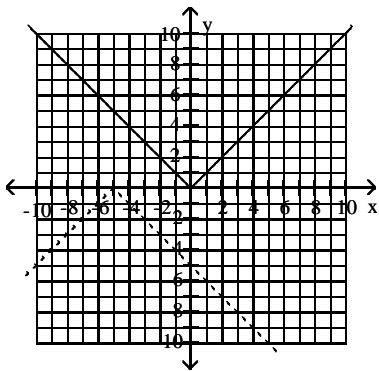

D)

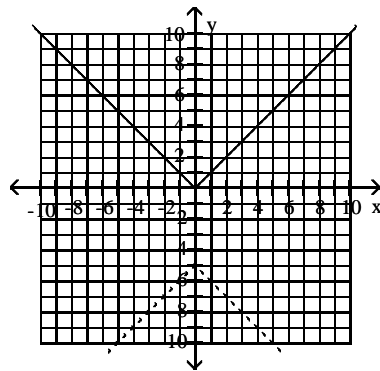

Begin by graphing the standard cubic function $f(x) = x^3$. Then use transformations of this graph to graph the given function.

5) $g(x) = -x^3 + 2$

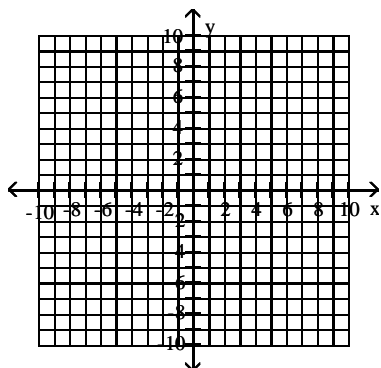

A)

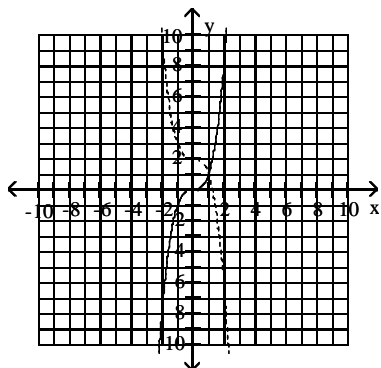

B)

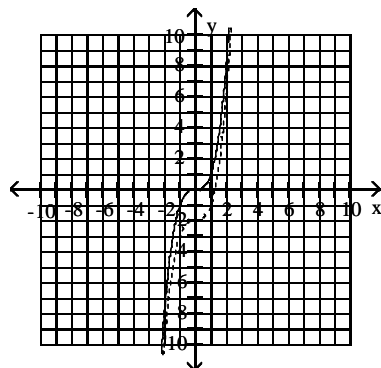

C)

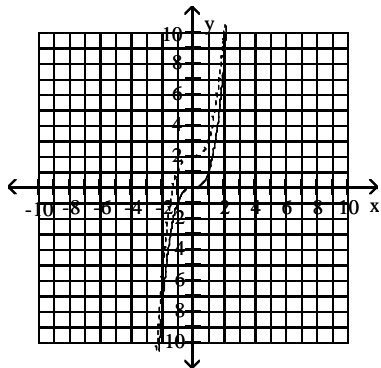

D)

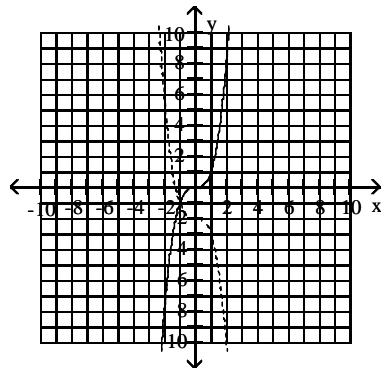

Use the graph of the function f , plotted with a solid line, to sketch the graph of the given function g .

6) $g(x) = -f(x) + 2$

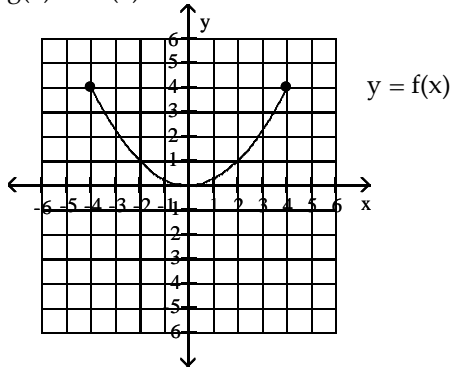

A)

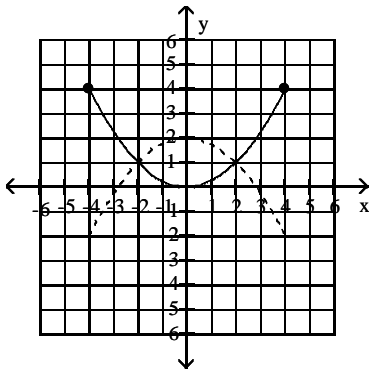

B)

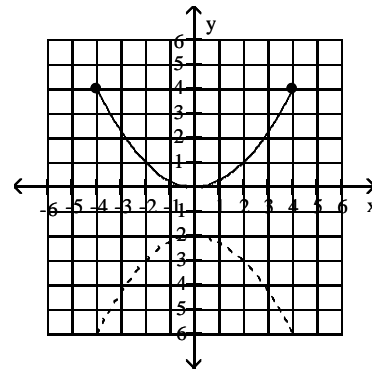

C)

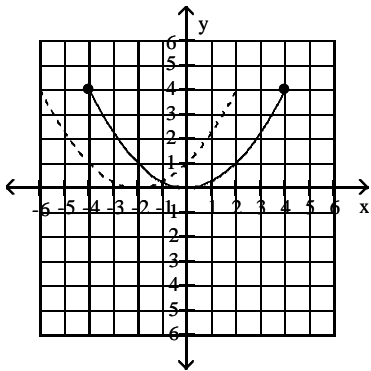

D)

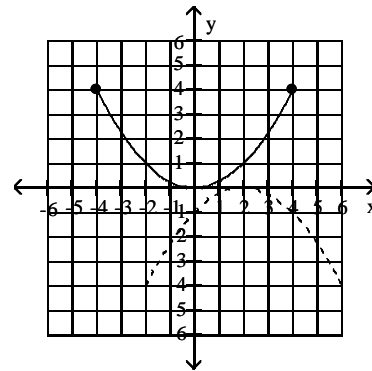

5 Use Vertical Stretching and Shrinking to Graph Functions

MULTIPLE CHOICE. Choose the one alternative that best completes the statement or answers the question.

Begin by graphing the standard absolute value function $f(x) = |x|$. Then use transformations of this graph to graph the given function.

1) $h(x) = 2|x| + 4$

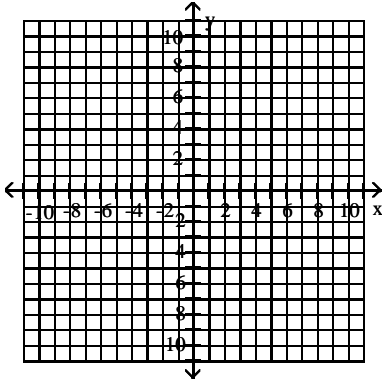

A)

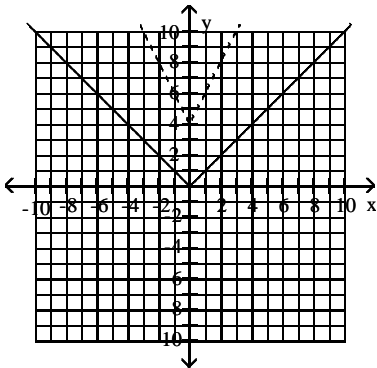

B)

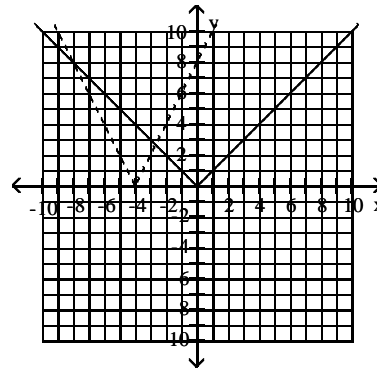

C)

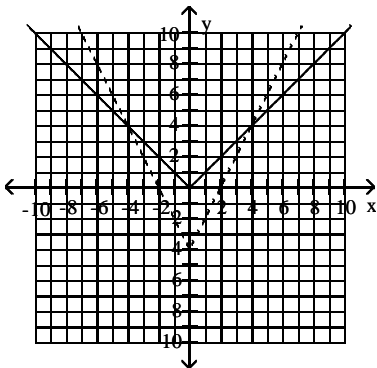

D)

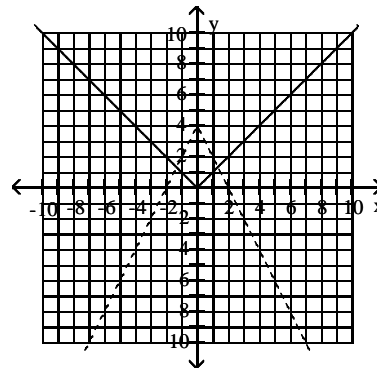

Begin by graphing the standard cubic function $f(x) = x^3$. Then use transformations of this graph to graph the given function.

$$2) g(x) = -\frac{1}{2}x^3$$

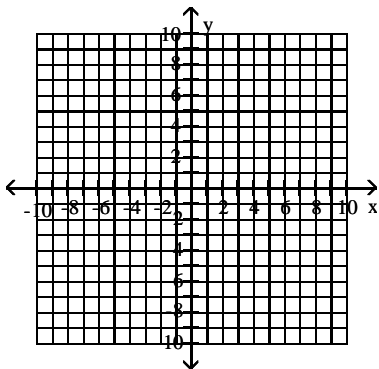

A)

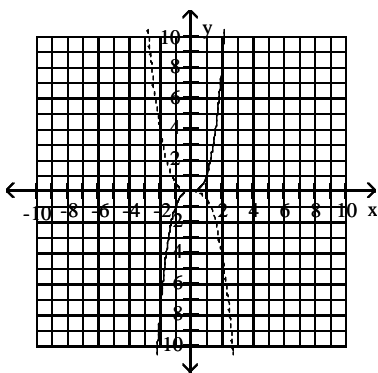

B)

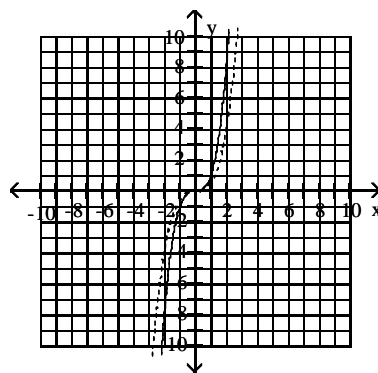

C)

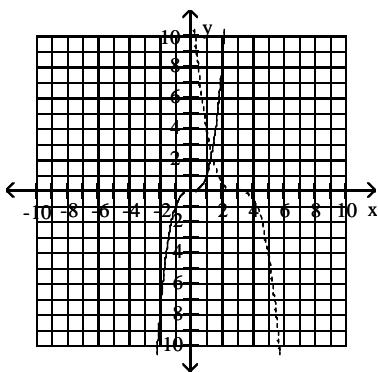

D)

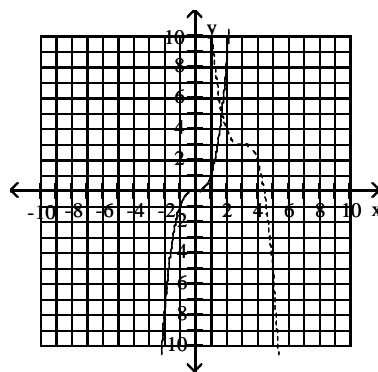

$$3) g(x) = \frac{1}{4}x^3$$

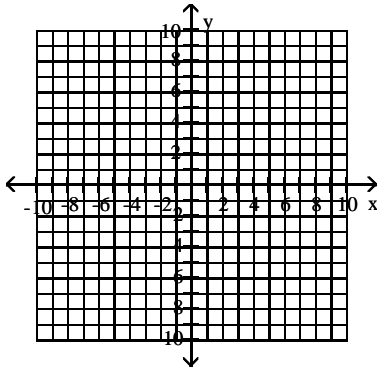

A)

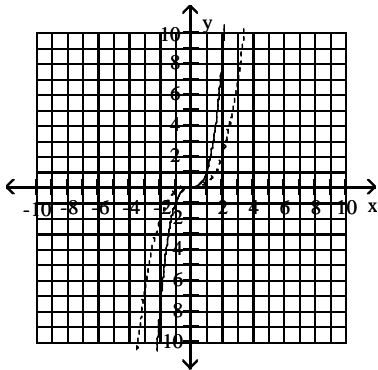

B)

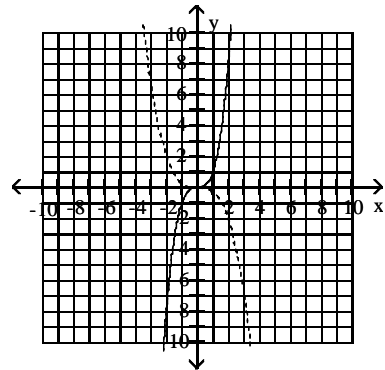

C)

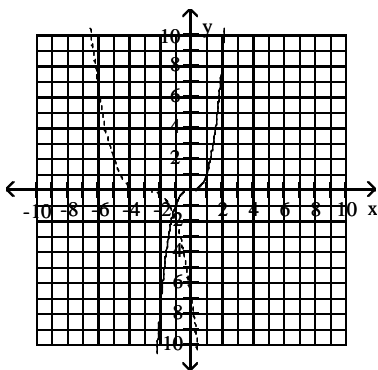

D)

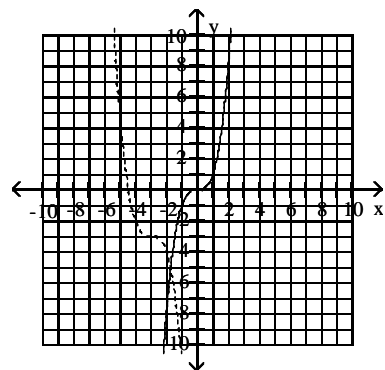

Begin by graphing the standard quadratic function $f(x) = x^2$. Then use transformations of this graph to graph the given function.

4) $g(x) = 2x^2$

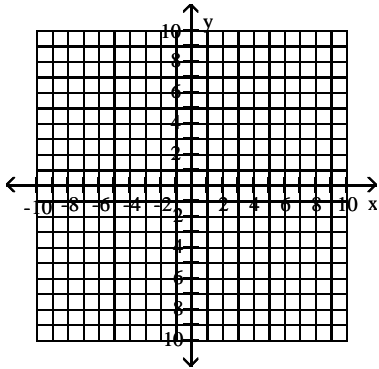

A)

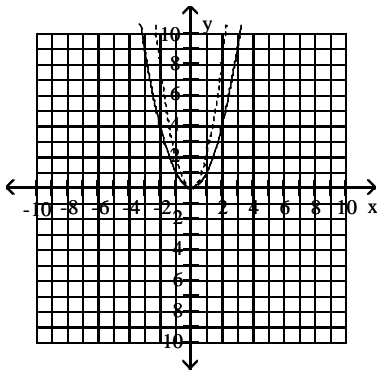

B)

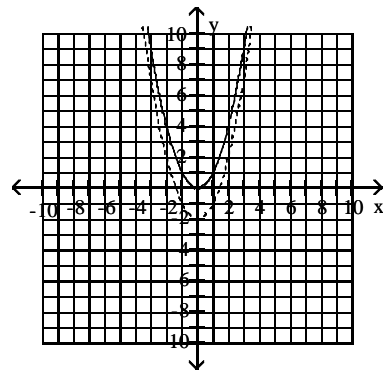

C)

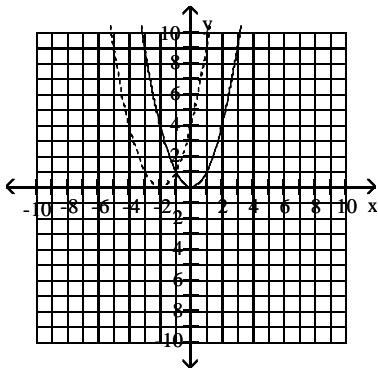

D)

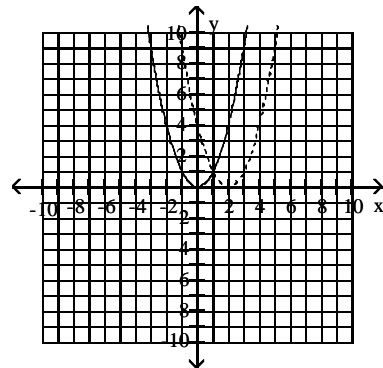

Begin by graphing the square root function $f(x) = \sqrt{x}$. Then use transformations of this graph to graph the given function.

5) $g(x) = 2\sqrt{x+5}$

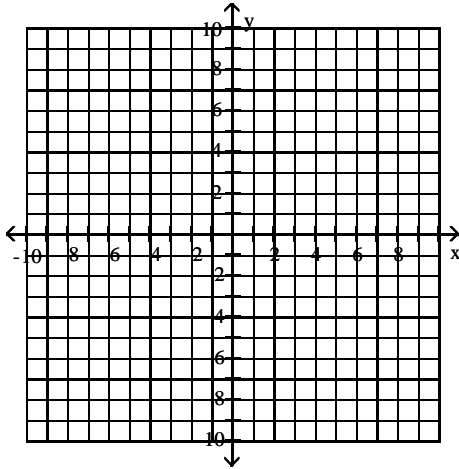

A)

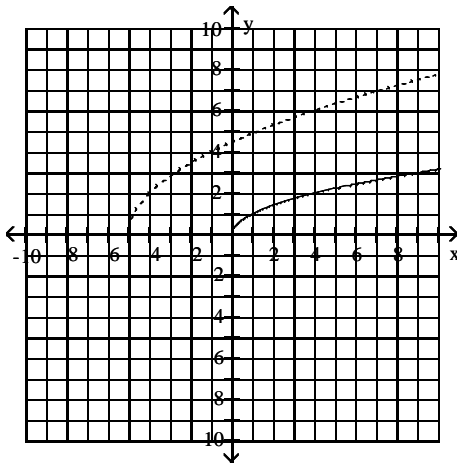

B)

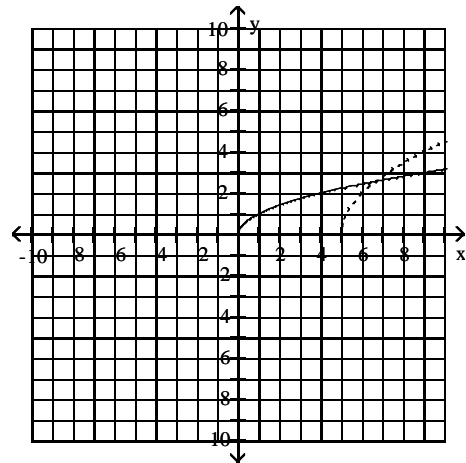

C)

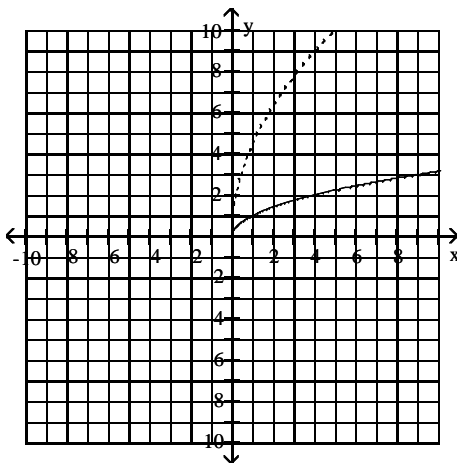

D)

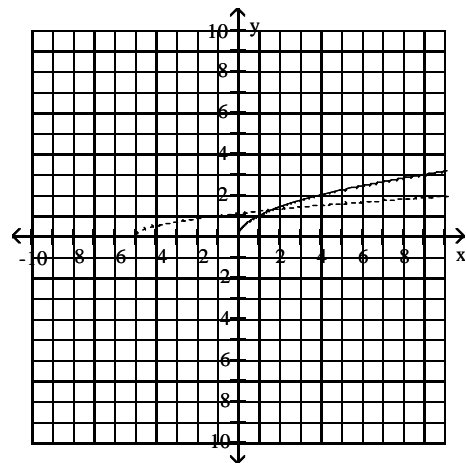

Use the graph of $y = f(x)$ to graph the given function g .

6) $g(x) = -2f(x)$

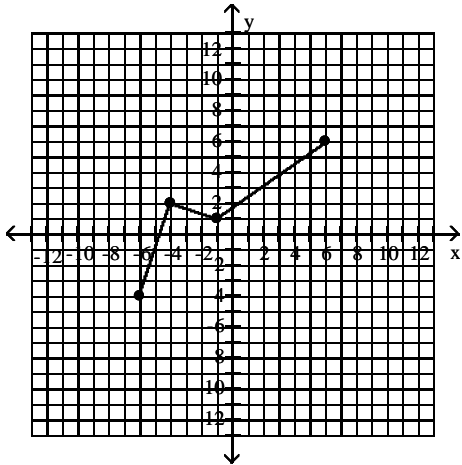

A)

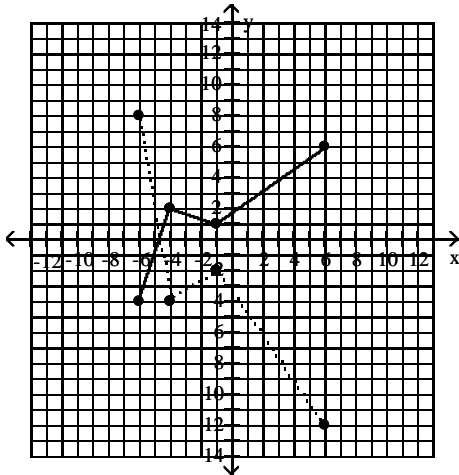

B)

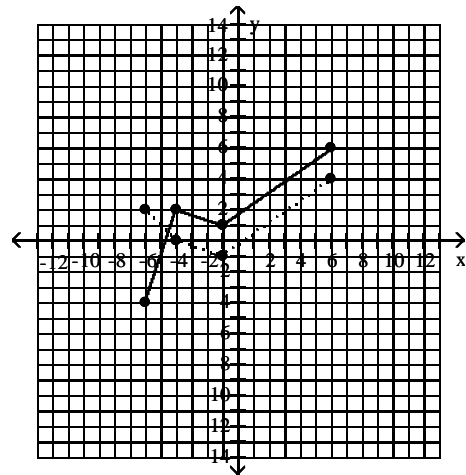

C)

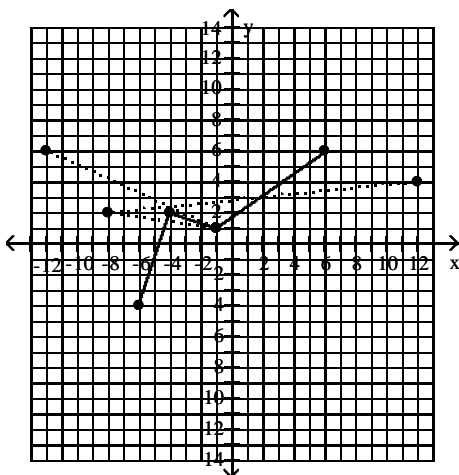

D)

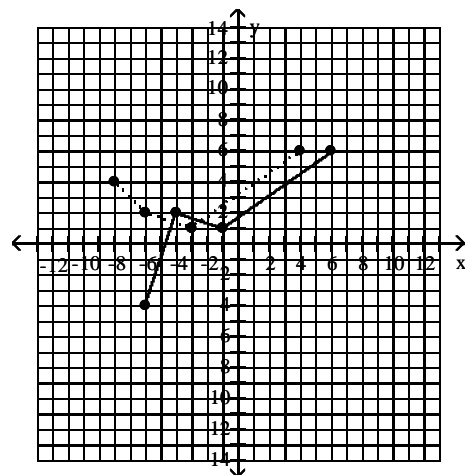

6 Use Horizontal Stretching and Shrinking to Graph Functions

MULTIPLE CHOICE. Choose the one alternative that best completes the statement or answers the question.

Begin by graphing the standard quadratic function $f(x) = x^2$. Then use transformations of this graph to graph the given function.

1) $h(x) = \left(\frac{1}{2}x + 2\right)^2$

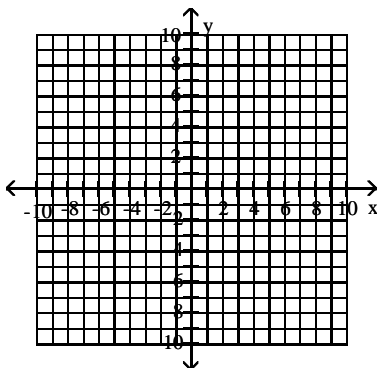

A)

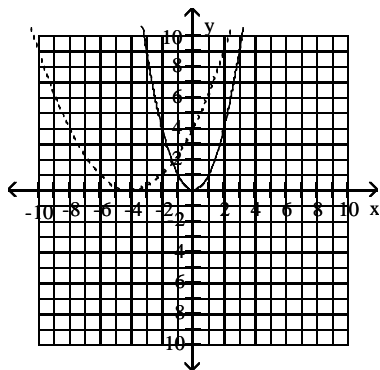

B)

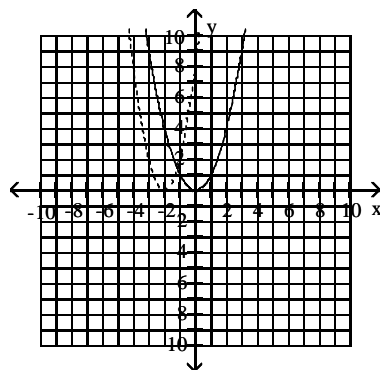

C)

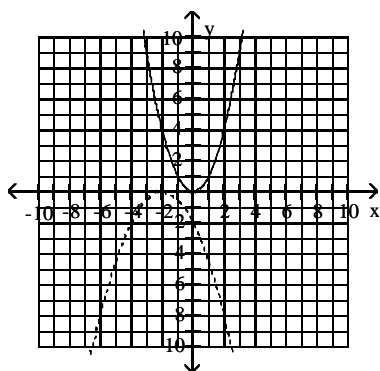

D)

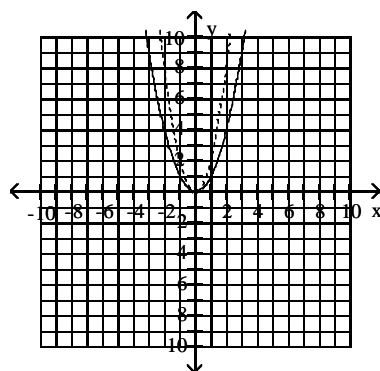

Begin by graphing the standard square root function $f(x) = \sqrt{x}$. Then use transformations of this graph to graph the given function.

2) $g(x) = \sqrt{\frac{1}{2}x + 4}$

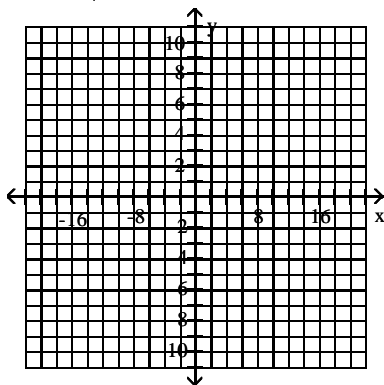

A)

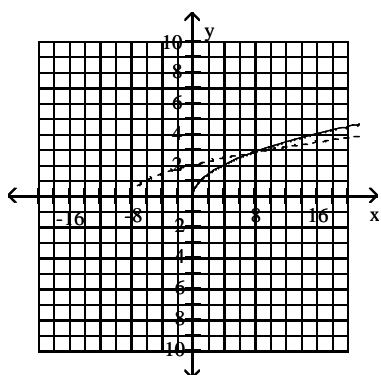

B)

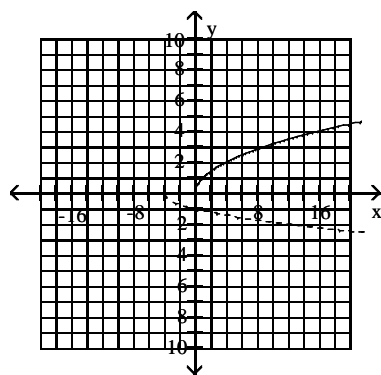

C)

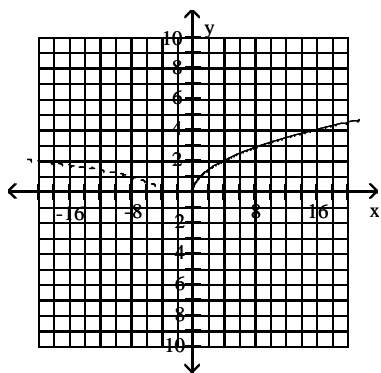

D)

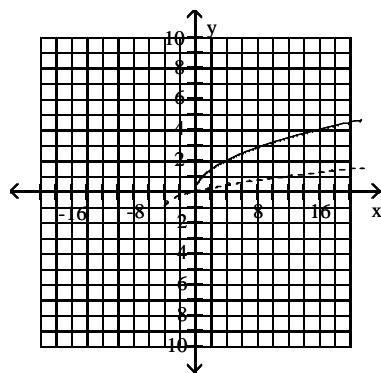

Begin by graphing the standard absolute value function $f(x) = |x|$. Then use transformations of this graph to graph the given function.

3) $g(x) = 2|2x|$

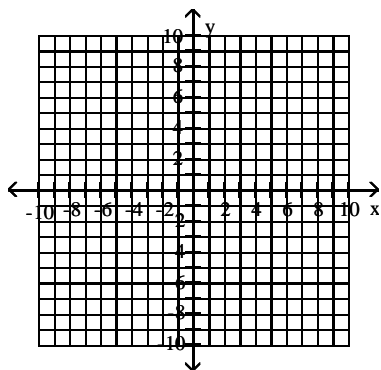

A)

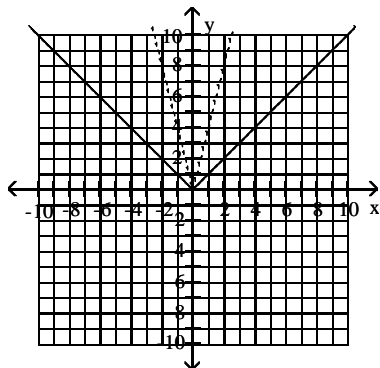

B)

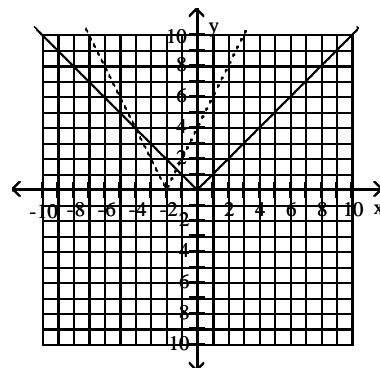

C)

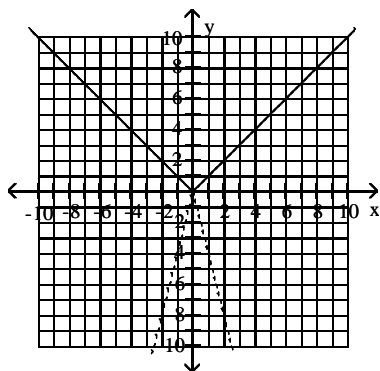

D)

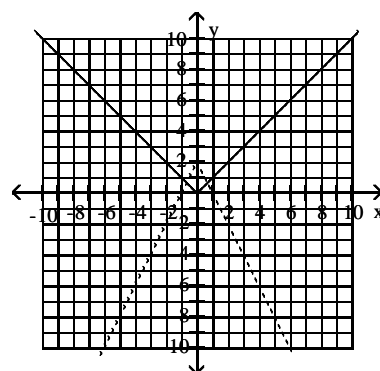

Begin by graphing the standard function $f(x) = x^3$. Then use transformations of this graph to graph the given function.

4) $h(x) = \frac{1}{2}(-2x)^3$

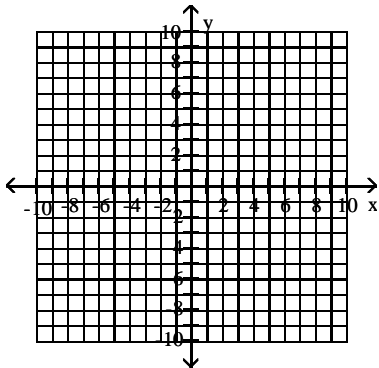

A)

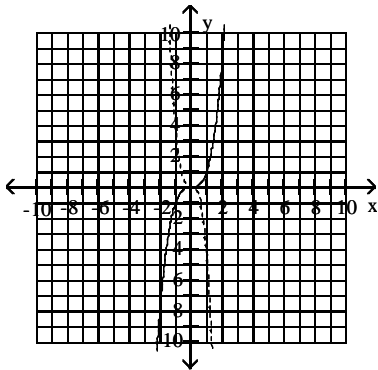

B)

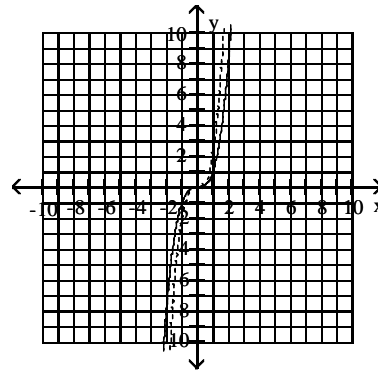

C)

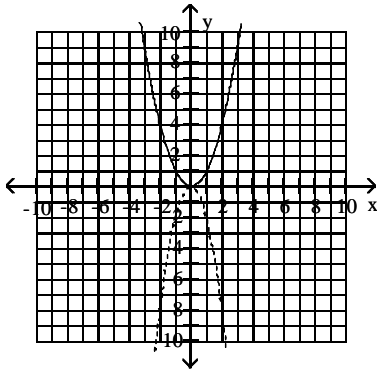

D)

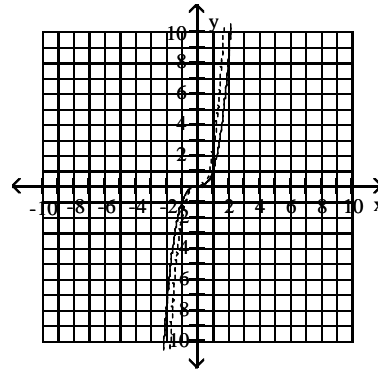

Use the graph of the function f , plotted with a solid line, to sketch the graph of the given function g .

$$5) g(x) = \frac{1}{3}x + 3$$

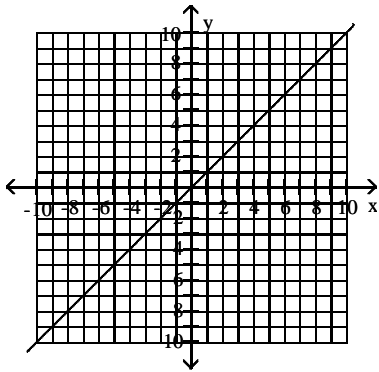

A)

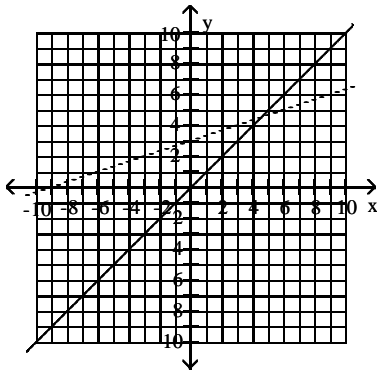

B)

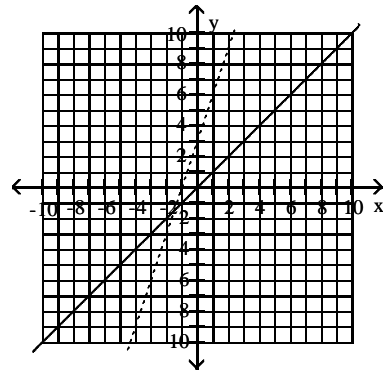

C)

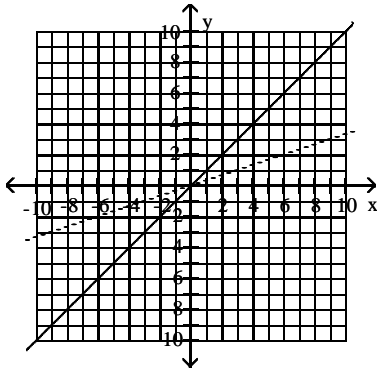

D)

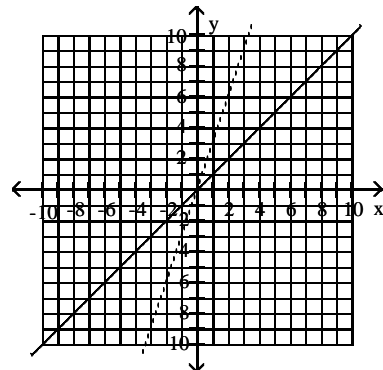

7 Graph Functions Involving a Sequence of Transformations

MULTIPLE CHOICE. Choose the one alternative that best completes the statement or answers the question.

Begin by graphing the standard quadratic function $f(x) = x^2$. Then use transformations of this graph to graph the given function.

1) $h(x) = (x - 7)^2 - 5$

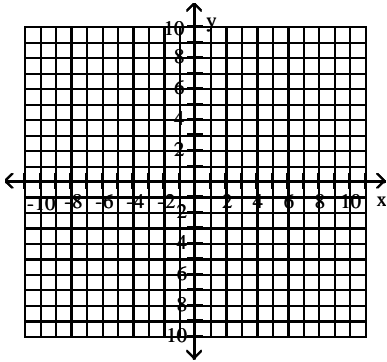

A)

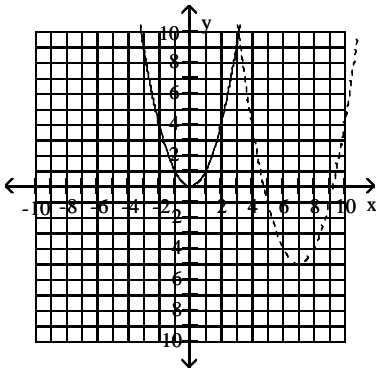

B)

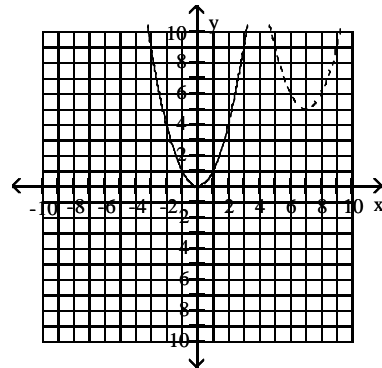

C)

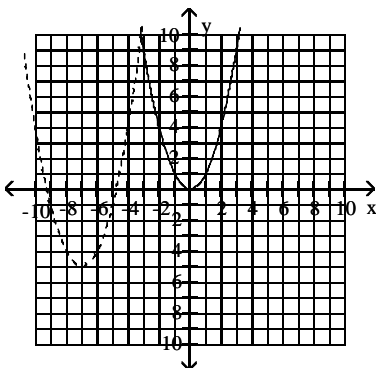

D)

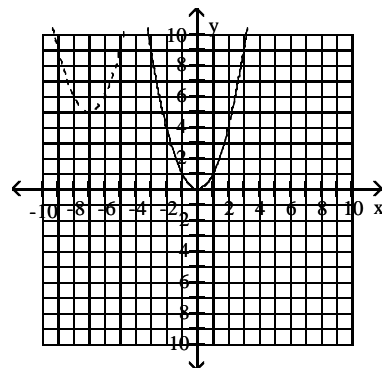

2) $h(x) = -(x + 3)^2 + 3$

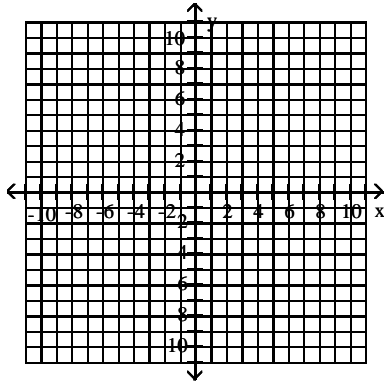

A)

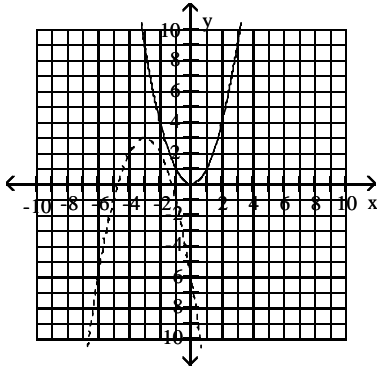

B)

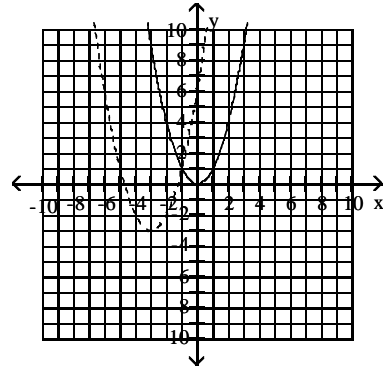

C)

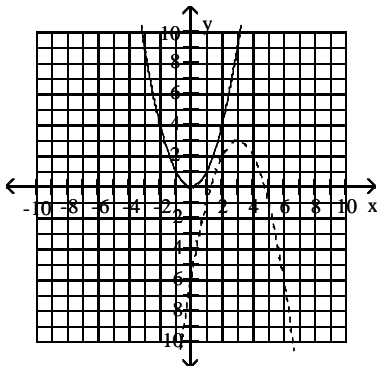

D)

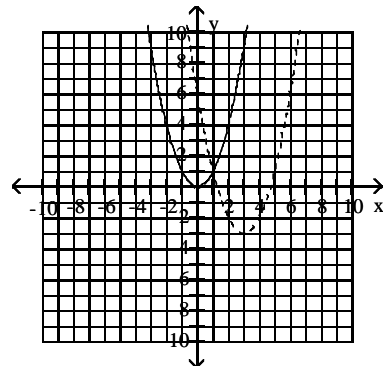

$$3) g(x) = -\frac{1}{2}(x+7)^2 - 2$$

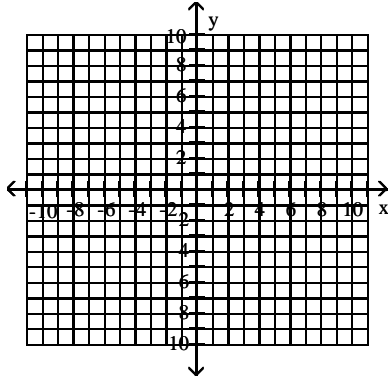

A)

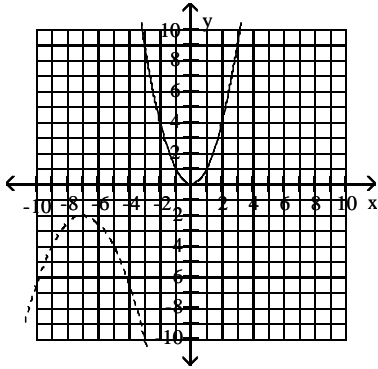

B)

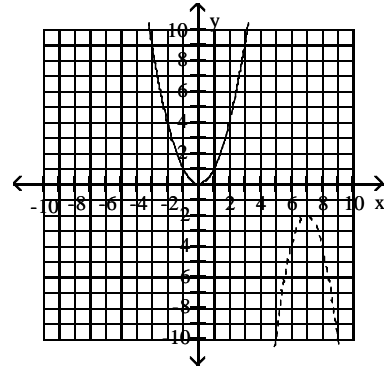

C)

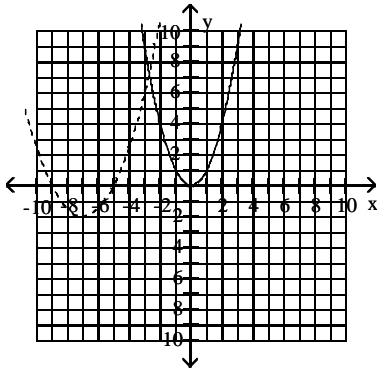

D)

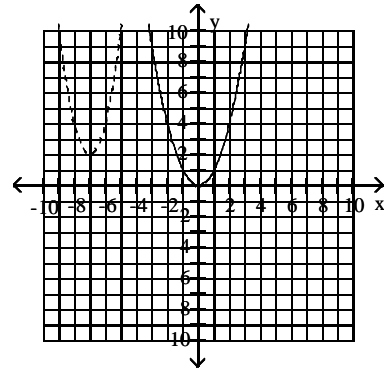

Begin by graphing the standard square root function $f(x) = \sqrt{x}$. Then use transformations of this graph to graph the given function.

4) $g(x) = -\sqrt{x+1} - 1$

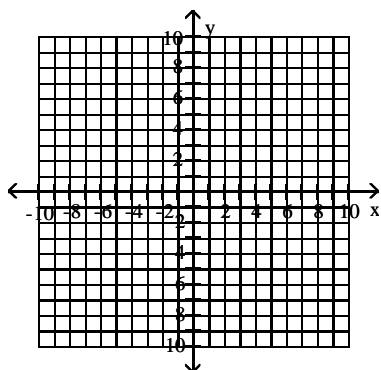

A)

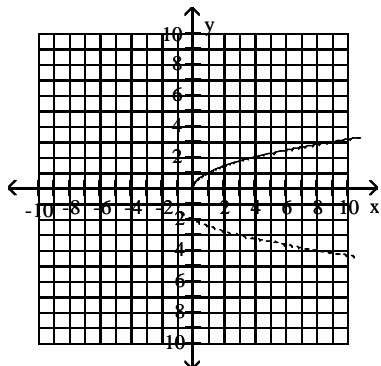

B)

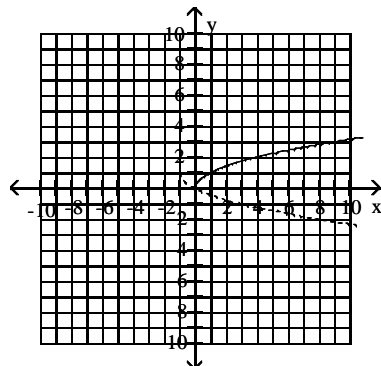

C)

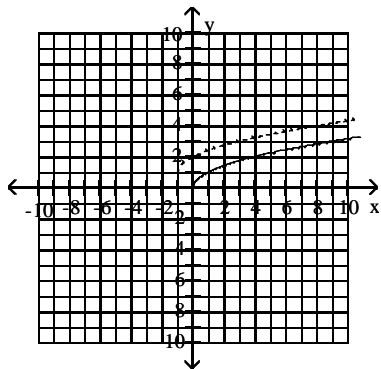

D)

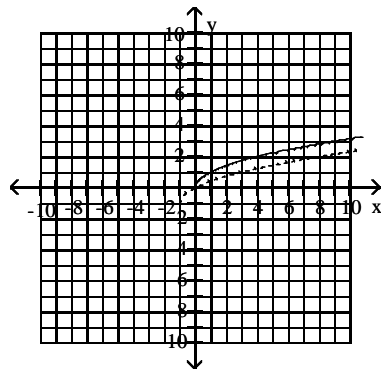

5) $h(x) = \sqrt{-x+2} - 2$

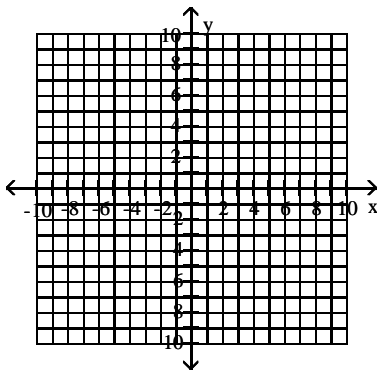

A)

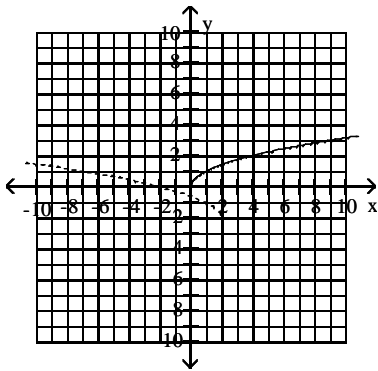

B)

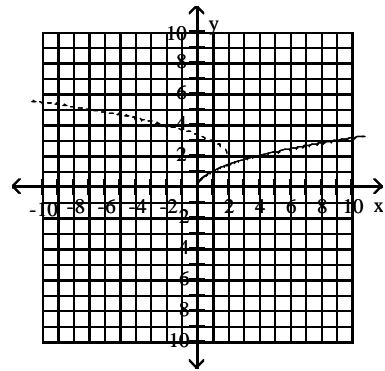

C)

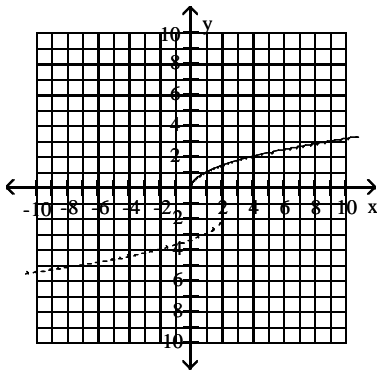

D)

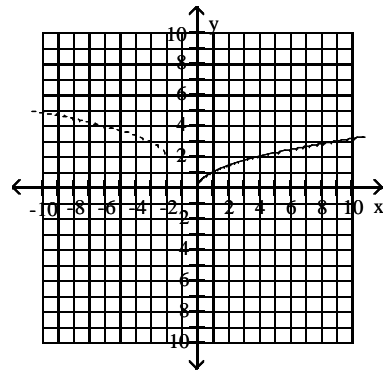

6) $g(x) = \sqrt{x-1} + 2$

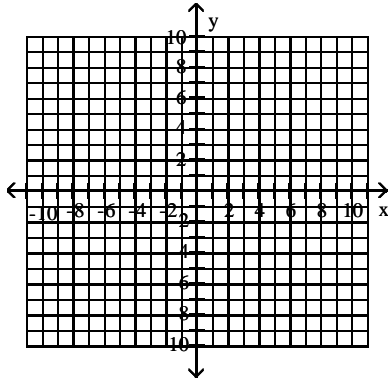

A)

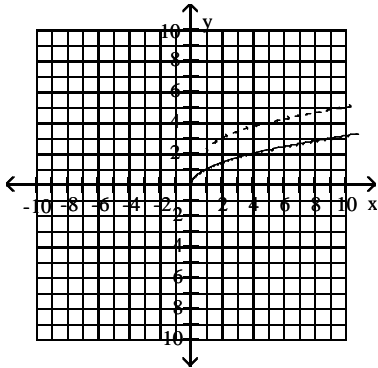

B)

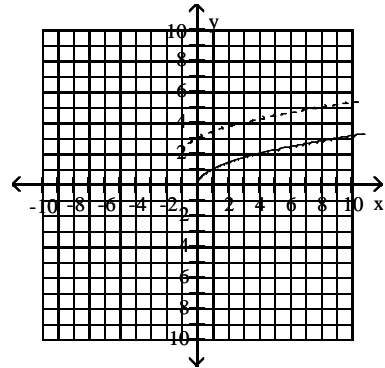

C)

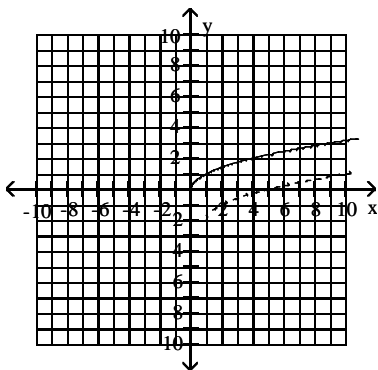

D)

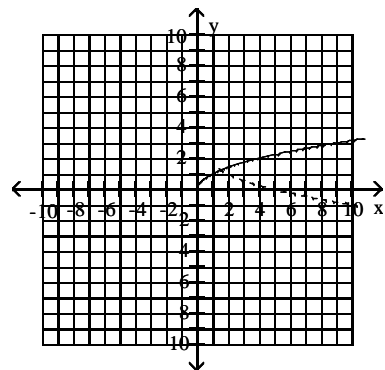

Begin by graphing the standard absolute value function $f(x) = |x|$. Then use transformations of this graph to graph the given function.

$$7) g(x) = \frac{1}{2}|x + 4| + 6$$

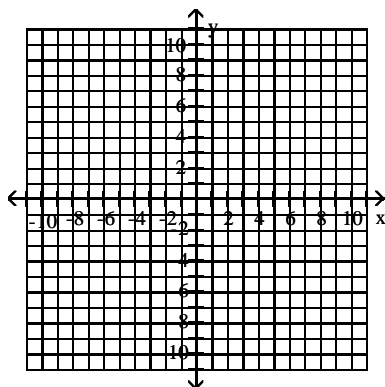

A)

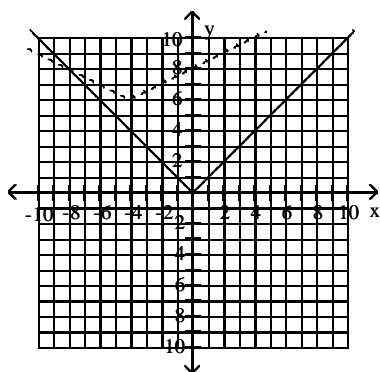

B)

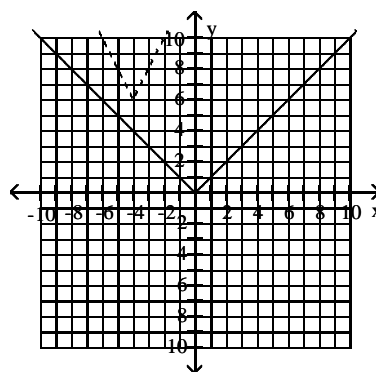

C)

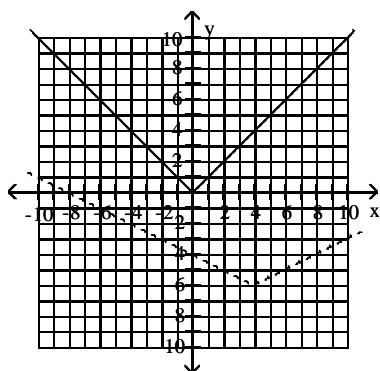

D)

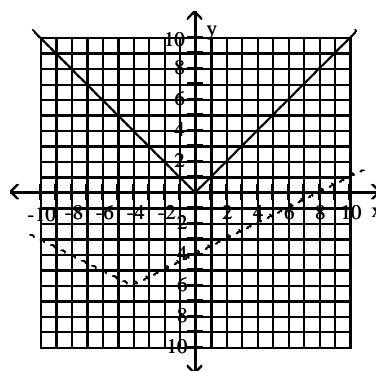

Begin by graphing the standard cubic function $f(x) = x^3$. Then use transformations of this graph to graph the given function.

8) $h(x) = (x + 3)^3 - 3$

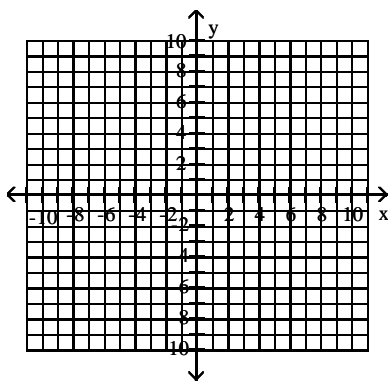

A)

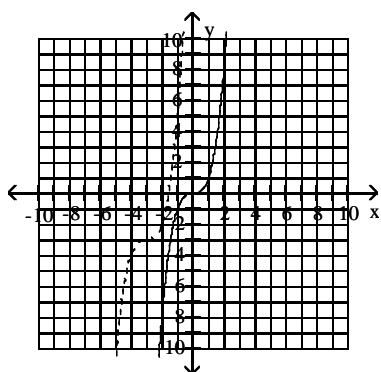

B)

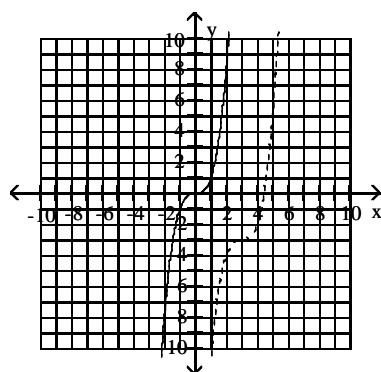

C)

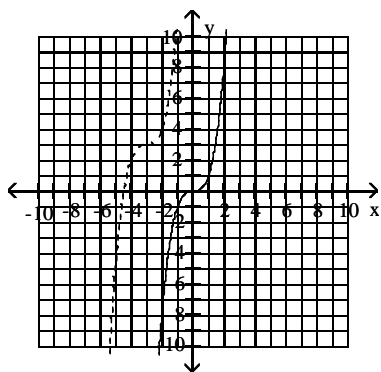

D)

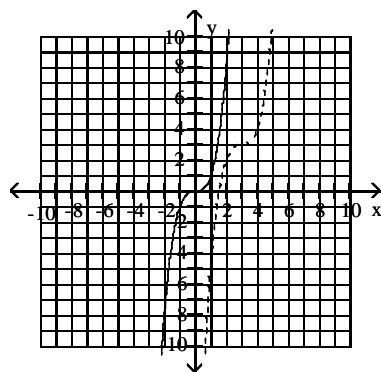

9) $g(x) = -(x - 2)^3 + 2$

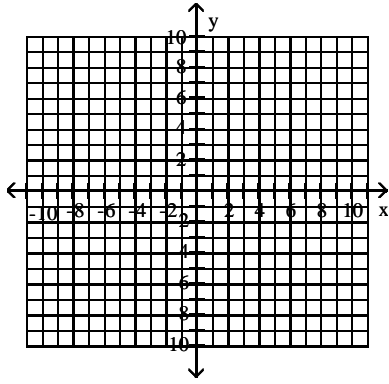

A)

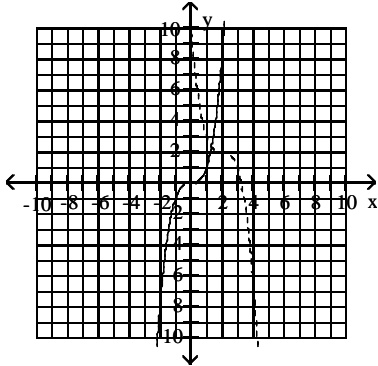

B)

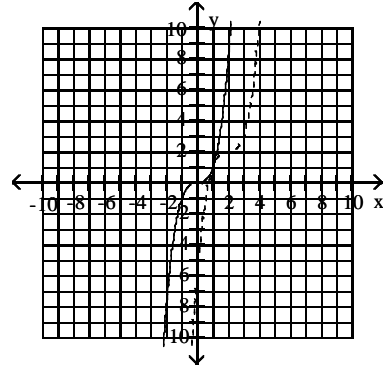

C)

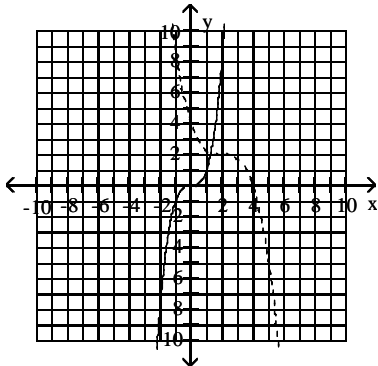

D)

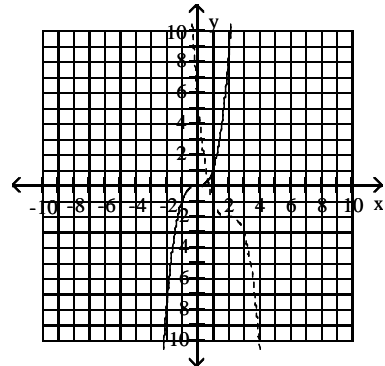

10) $h(x) = \frac{1}{2}x^3 - 5$

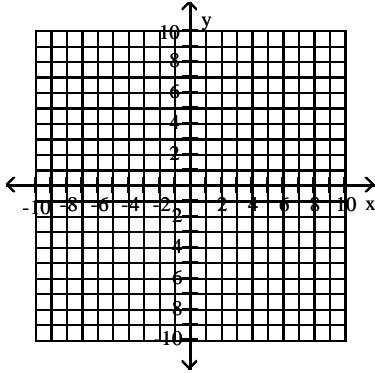

A)

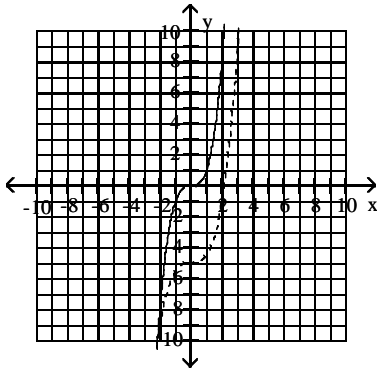

B)

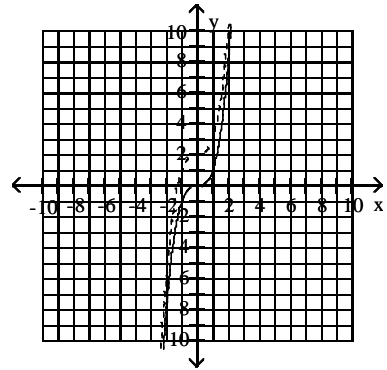

C)

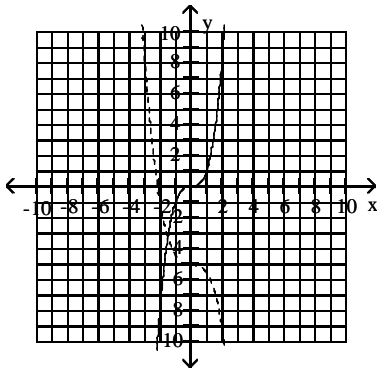

D)

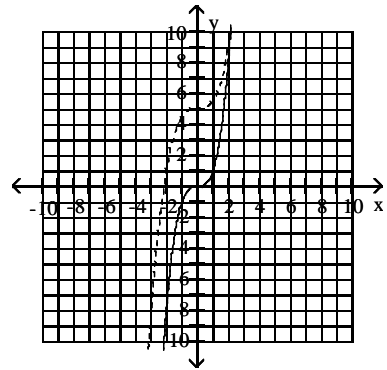

Use the graph of the function f , plotted with a solid line, to sketch the graph of the given function g .

11) $g(x) = f(x - 2) - 2$

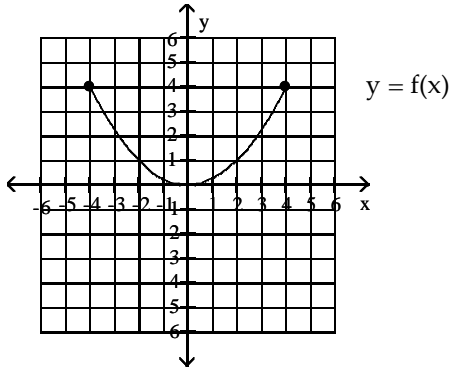

A)

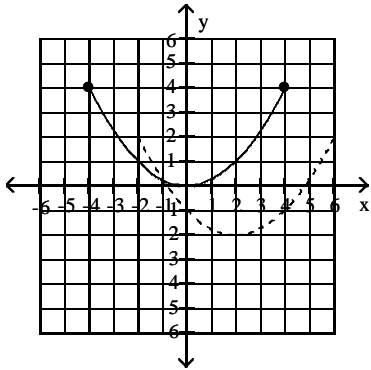

B)

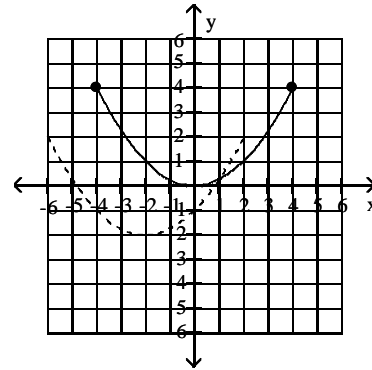

C)

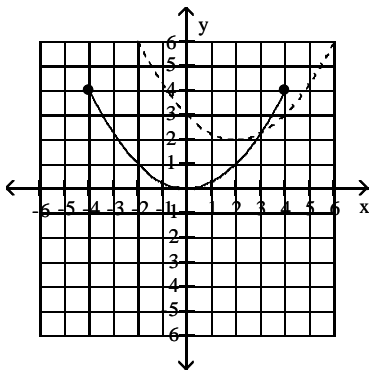

D)

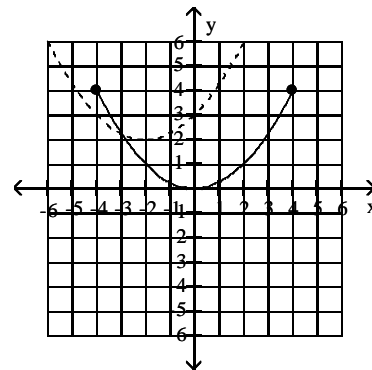

12) $g(x) = -f(x - 1) + 2$

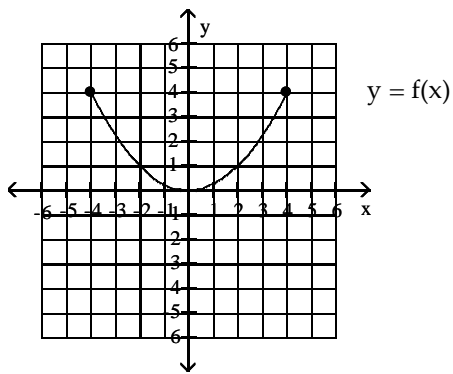

A)

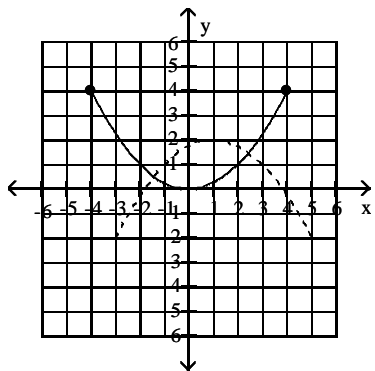

B)

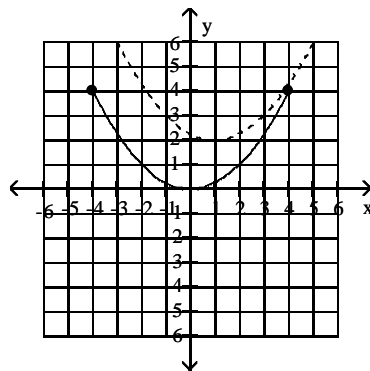

C)

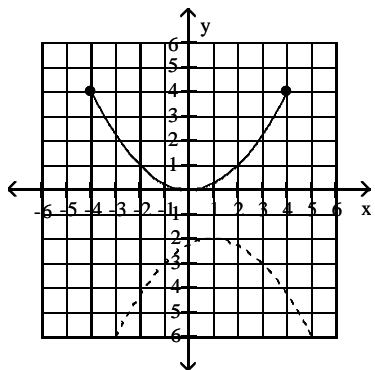

D)

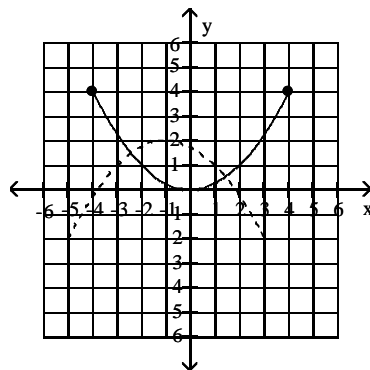

Begin by graphing the cube root function $f(x) = \sqrt[3]{x}$. Then use transformations of this graph to graph the given function.

13) $g(x) = -\sqrt[3]{x+1}$

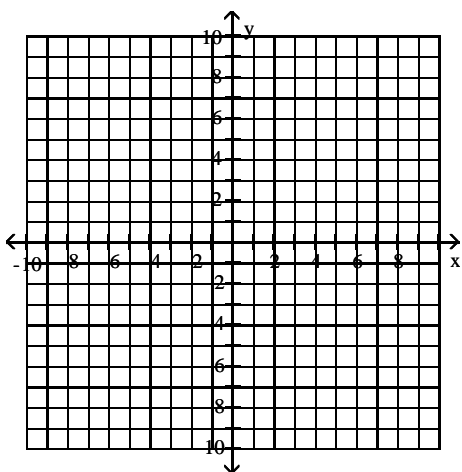

A)

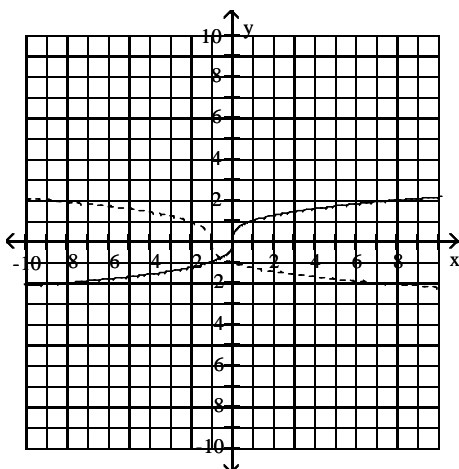

B)

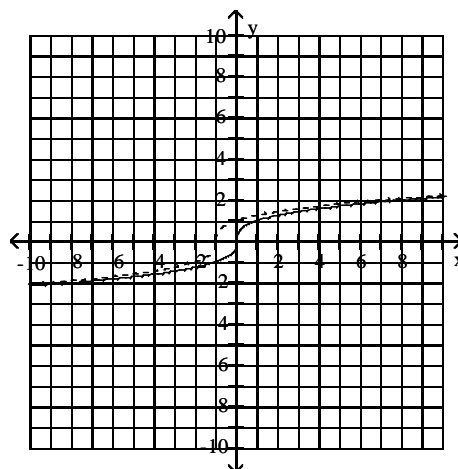

C)

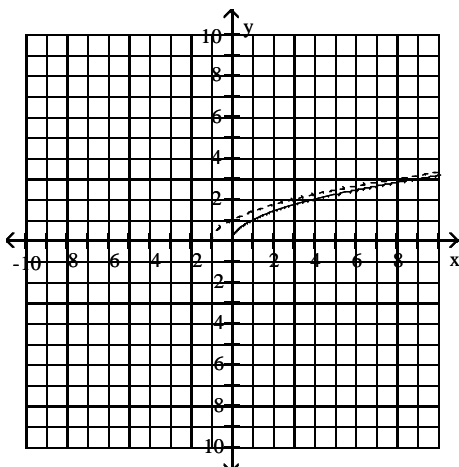

D)

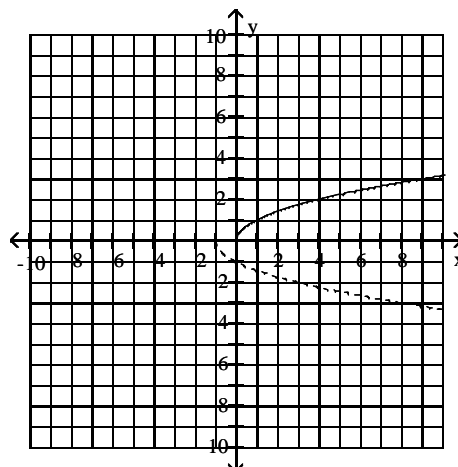

2.6 Combinations of Functions; Composite Functions

1 Find the Domain of a Function

MULTIPLE CHOICE. Choose the one alternative that best completes the statement or answers the question.

Find the domain of the function.

1) $f(x) = -9x + 1$

A) $(-\infty, \infty)$

B) $[-1, \infty)$

C) $(-\infty, 0) \cup (0, \infty)$

D) $(0, \infty)$

2) $f(x) = x^2 + 3$

A) $(-\infty, \infty)$

B) $[-3, \infty)$

C) $(-3, \infty)$

D) $(-\infty, -3) \cup (-3, \infty)$

3) $f(x) = \frac{x^2}{x^2 + 10}$

A) $(-\infty, \infty)$

B) $(-\infty, -10) \cup (-10, \infty)$

C) $(-10, \infty)$

D) $(-\infty, 0) \cup (0, \infty)$

4) $g(x) = \frac{2x}{x^2 - 4}$

A) $(-\infty, -2) \cup (-2, 2) \cup (2, \infty)$

B) $(-\infty, 0) \cup (0, \infty)$

C) $(4, \infty)$

D) $(-\infty, \infty)$

5) $h(x) = \frac{x - 1}{x^3 - 64x}$

A) $(-\infty, -8) \cup (-8, 0) \cup (0, 8) \cup (8, \infty)$

B) $(-\infty, 0) \cup (0, \infty)$

C) $(-\infty, 1) \cup (1, \infty)$

D) $(-\infty, \infty)$

6) $f(x) = \sqrt{10 - x}$

A) $(-\infty, 10]$

B) $(-\infty, 10) \cup (10, \infty)$

C) $(-\infty, \sqrt{10}]$

D) $(-\infty, \sqrt{10}) \cup (\sqrt{10}, \infty)$

7) $\frac{x}{\sqrt{x - 9}}$

A) $(9, \infty)$

B) $[9, \infty)$

C) $(-\infty, 9) \cup (9, \infty)$

D) $(-\infty, \infty)$

8) $f(x) = \frac{1}{x - 6}$

A) $(-\infty, 6) \cup (6, \infty)$

B) $(-\infty, \infty)$

C) $(6, \infty)$

D) $(-\infty, 0) \cup (0, \infty)$

9) $f(x) = \frac{5x}{x + 7}$

A) $(-\infty, -7) \cup (-7, \infty)$

B) $(-\infty, \infty)$

C) $(-\infty, 0) \cup (0, \infty)$

D) $(-\infty, -7)$

$$10) f(x) = x - \frac{8}{x-1}$$

A) $(-\infty, 1) \cup (1, \infty)$

B) $(-\infty, \infty)$

C) $(-\infty, 1) \cup (1, 8) \cup (8, \infty)$

D) $(-\infty, 8) \cup (8, \infty)$

$$11) f(x) = \frac{1}{x-6} + \frac{4}{x-4}$$

A) $(-\infty, 4) \cup (4, 6) \cup (6, \infty)$

B) $(-\infty, \infty)$

C) $(-\infty, 4) \cup (4, \infty)$

D) $(-\infty, 6) \cup (6, \infty)$

2 Combine Functions Using the Algebra of Functions, Specifying Domains

MULTIPLE CHOICE. Choose the one alternative that best completes the statement or answers the question.

Given functions f and g , perform the indicated operations.

1) $f(x) = 2x - 6$, $g(x) = 9x - 8$

Find $f - g$.

A) $-7x + 2$

B) $-7x - 14$

C) $11x - 14$

D) $7x - 2$

2) $f(x) = 9x^2 - 7x$, $g(x) = x^2 - 5x - 14$

Find $\frac{f}{g}$.

A) $\frac{9x^2 - 7x}{x^2 - 5x - 14}$

B) $\frac{9x}{x+1}$

C) $\frac{9x-7}{-5}$

D) $\frac{9-x}{14}$

3) $f(x) = 3 - 5x$, $g(x) = -8x + 5$

Find $f + g$.

A) $-13x + 8$

B) $-8x + 3$

C) $-5x$

D) $3x + 8$

4) $f(x) = \sqrt{2x+3}$, $g(x) = \sqrt{16x-25}$

Find fg .

A) $(\sqrt{2x+3})(\sqrt{16x-25})$

B) $(4x-5)(\sqrt{2x+3})$

C) $(2x+3)(16x-25)$

D) $(2x+3)(4x-5)$

5) $f(x) = 3x + 2$, $g(x) = 2x + 8$

Find fg .

A) $6x^2 + 28x + 16$

B) $6x^2 + 12x + 16$

C) $5x^2 + 28x + 10$

D) $6x^2 + 16$

Given functions f and g , determine the domain of $f + g$.

6) $f(x) = 3x + 10$, $g(x) = 5x + 5$

A) $(-\infty, \infty)$

B) $(-\infty, 0) \cup (0, \infty)$

C) $(0, \infty)$

D) $(-\infty, -3) \cup (-3, \infty)$

7) $f(x) = 2x - 1$, $g(x) = \frac{2}{x-9}$

A) $(-\infty, 9) \cup (9, \infty)$

B) $(-\infty, \infty)$

C) $(0, \infty)$

D) $(-\infty, -2) \cup (-2, \infty)$

8) $f(x) = 5x - 5$, $g(x) = \frac{4}{x + 6}$

- A) $(-\infty, -6)$ or $(-6, \infty)$ B) $(-\infty, \infty)$ C) $(0, \infty)$ D) $(-\infty, -4)$ or $(-4, \infty)$

9) $f(x) = \frac{2x}{x - 2}$, $g(x) = \frac{4}{x + 1}$

- A) $(-\infty, -1)$ or $(-1, 2)$ or $(2, \infty)$ B) $(-\infty, \infty)$
 C) $(-\infty, -2)$ or $(-2, 1)$ or $(1, \infty)$ D) $(-\infty, -4)$ or $(-4, -2)$ or $(-2, \infty)$

10) $f(x) = 3x^2 - 2$, $g(x) = 2x^3 - 4$

- A) $(-\infty, \infty)$ B) $(-\infty, 0)$ or $(0, \infty)$
 C) $(0, \infty)$ D) $(-\infty, -3)$ or $(-3, -2)$ or $(-2, \infty)$

Find the domain of the indicated combined function.

11) Find the domain of $(f - g)(x)$ when $f(x) = 6x - 3$ and $g(x) = 4x - 8$.

- A) Domain: $(-\infty, \infty)$ B) Domain: $(-3, 6)$ C) Domain: $(-6, 3)$ D) Domain: $(-3, \infty)$

12) Find the domain of $(fg)(x)$ when $f(x) = \sqrt{6x + 2}$ and $g(x) = \sqrt{9x - 2}$.

- A) Domain: $\left[\frac{2}{9}, \infty\right)$ B) Domain: $[0, \infty)$ C) Domain: $(-\infty, \infty)$ D) Domain: $\left[-\frac{2}{9}, \infty\right)$

13) Find the domain of $\left(\frac{f}{g}\right)(x)$ when $f(x) = 2x^2 - 5x$ and $g(x) = x^2 - 2x - 7$.

- A) Domain: $(-\infty, 1 - 2\sqrt{2}) \cup (1 - 2\sqrt{2}, 1 + 2\sqrt{2}) \cup (1 + 2\sqrt{2}, \infty)$
 B) Domain: $(-\infty, \infty)$
 C) Domain: $(-\infty, 1 - 2\sqrt{2}) \cup (1 - 2\sqrt{2}, \infty)$
 D) Domain: $(-\infty, 1 - 2\sqrt{2}) \cap (1 - 2\sqrt{2}, 1 + 2\sqrt{2}) \cap (1 - 2\sqrt{2}, \infty)$

14) Find the domain of $(f + g)(x)$ when $f(x) = 9 - 9x$ and $g(x) = -6x + 8$.

- A) Domain: $(-\infty, \infty)$ B) Domain: $(-\infty, 6)$ C) Domain: $(-9, \infty)$ D) Domain: $(-9, 9)$

Solve the problem.

- 15) The following graph shows the private, public and total national school enrollment for students for select years from 1970 through 2000.

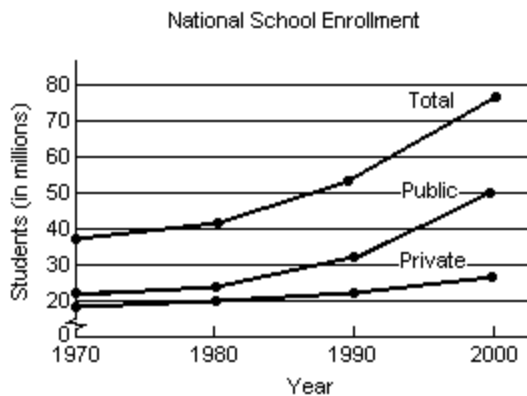

- i) How is the graph for total school enrollment, T , determined from the graph of the private enrollment, r , and the public enrollment, u ?
- ii) During which 10-year period did the total number of students enrolled increase the least?
- iii) During which 10-year period did the total number of students enrolled increase the most?
- A) i) T is the sum of r and u .
 ii) 1970 - 1980
 iii) 1990-2000
- B) i) T is the sum of r and u .
 ii) 1990-2000
 iii) 1970-1980
- C) i) T is the sum of r and u .
 ii) 1970 - 1980
 iii) 1980-1990
- D) i) T is the difference of r and u .
 ii) 1970 - 1980
 iii) 1990-2000
- 16) A firm is considering a new product. The accounting department estimates that the total cost, $C(x)$, of producing x units will be

$$C(x) = 95x + 4200.$$
 The sales department estimates that the revenue, $R(x)$, from selling x units will be

$$R(x) = 105x,$$
 but that no more than 629 units can be sold at that price. Find and interpret $(R - C)(629)$.
- A) \$2090 profit, income exceeds cost
 It is worth it to develop product.
- B) -\$2090 loss, cost exceeds income
 It is not worth it to develop product.
- C) \$130,000 profit, income exceeds cost
 It is worth it to develop product.
- D) \$1049 profit, income exceeds cost
 It is worth it to develop product.
- 17) The function $f(t) = -0.14t^2 + 0.52t + 31.6$ models the U.S. population in millions, ages 65 and older, where t represents years after 1990. The function $g(t) = 0.54t^2 + 11.08t + 107.7$ models the total yearly cost of Medicare in billions of dollars, where t represents years after 1990. What does the function $\frac{g}{f}$ represent? Find $\frac{g}{f}(5)$.
- A) Cost per person in thousands of dollars. \$5.75 thousand
- B) Cost per person in thousands of dollars. \$0.21 thousand
- C) Cost per person in thousands of dollars. \$0.17 thousand
- D) Cost per person in thousands of dollars. \$11.30 thousand

3 Form Composite Functions

MULTIPLE CHOICE. Choose the one alternative that best completes the statement or answers the question.

For the given functions f and g , find the indicated composition.

1) $f(x) = 17x^2 - 6x$, $g(x) = 8x - 5$
 $(f \circ g)(8)$

- A) 58,823 B) 8315 C) 50,508 D) 61,360

2) $f(x) = x^2 + 2x + 2$, $g(x) = x^2 - 2x - 3$
 $(f \circ g)(-3)$

- A) 170 B) 17 C) 136 D) 51

3) $f(x) = 3x + 9$, $g(x) = 5x - 1$
 $(f \circ g)(x)$

- A) $15x + 6$ B) $15x + 12$ C) $15x + 8$ D) $15x + 44$

4) $f(x) = -6x + 3$, $g(x) = 2x + 5$
 $(g \circ f)(x)$

- A) $-12x + 11$ B) $-12x + 33$ C) $12x + 11$ D) $-12x - 1$

5) $f(x) = \frac{6}{x+8}$, $g(x) = \frac{7}{8x}$

$(f \circ g)(x)$

- A) $\frac{48x}{7+64x}$ B) $\frac{7x+56}{48x}$ C) $\frac{48x}{7-64x}$ D) $\frac{6x}{7+64x}$

6) $f(x) = \frac{x-5}{7}$, $g(x) = 7x + 5$

$(g \circ f)(x)$

- A) x B) $7x + 30$ C) $x + 10$ D) $x - \frac{5}{7}$

7) $f(x) = 4x^2 + 2x + 8$, $g(x) = 2x - 6$
 $(g \circ f)(x)$

- A) $8x^2 + 4x + 10$ B) $8x^2 + 4x + 22$ C) $4x^2 + 4x + 10$ D) $4x^2 + 2x + 2$

4 Determine Domains for Composite Functions

MULTIPLE CHOICE. Choose the one alternative that best completes the statement or answers the question.

Find the domain of the composite function $f \circ g$.

1) $f(x) = 3x + 30$, $g(x) = x + 6$

- A) $(-\infty, \infty)$ B) $(-\infty, -16)$ or $(-16, \infty)$
C) $(-\infty, 16)$ or $(16, \infty)$ D) $(-\infty, -10)$ or $(-10, -6)$ or $(-6, \infty)$

$$2) f(x) = \frac{2}{x+9}, \quad g(x) = x + 5$$

A) $(-\infty, -14)$ or $(-14, \infty)$

C) $(-\infty, -9)$ or $(-9, -5)$ or $(-5, \infty)$

B) $(-\infty, -9)$ or $(-9, \infty)$

D) $(-\infty, \infty)$

$$3) f(x) = x + 3, \quad g(x) = \frac{7}{x+8}$$

A) $(-\infty, -8)$ or $(-8, \infty)$

C) $(-\infty, -8)$ or $(-8, -3)$ or $(-3, \infty)$

B) $(-\infty, -11)$ or $(-11, \infty)$

D) $(-\infty, \infty)$

$$4) f(x) = \frac{3}{x+8}, \quad g(x) = \frac{24}{x}$$

A) $(-\infty, -3)$ or $(-3, 0)$ or $(0, \infty)$

C) $(-\infty, -8)$ or $(-8, -3)$ or $(-3, 0)$ or $(0, \infty)$

B) $(-\infty, -8)$ or $(-8, 0)$ or $(0, \infty)$

D) $(-\infty, \infty)$

$$5) f(x) = \sqrt{x}; \quad g(x) = 5x + 20$$

A) $[-4, \infty)$

B) $[0, \infty)$

C) $(-\infty, -4]$ or $[0, \infty)$

D) $(-\infty, \infty)$

$$6) f(x) = 6x + 24; \quad g(x) = \sqrt{x}$$

A) $[0, \infty)$

B) $[-4, \infty)$

C) $(-\infty, -4]$ or $[0, \infty)$

D) $(-\infty, \infty)$

5 Write Functions as Compositions

MULTIPLE CHOICE. Choose the one alternative that best completes the statement or answers the question.

Find functions f and g so that $h(x) = (f \circ g)(x)$.

$$1) h(x) = \frac{1}{x^2 - 4}$$

A) $f(x) = 1/x, g(x) = x^2 - 4$

C) $f(x) = 1/x^2, g(x) = -1/4$

B) $f(x) = 1/4, g(x) = x^2 - 4$

D) $f(x) = 1/x^2, g(x) = x - 4$

$$2) h(x) = |4x + 6|$$

A) $f(x) = |x|, g(x) = 4x + 6$

C) $f(x) = |-x|, g(x) = 4x - 6$

B) $f(x) = -|x|, g(x) = 4x + 6$

D) $f(x) = x, g(x) = 4x + 6$

$$3) h(x) = \frac{1}{x^2} + 4$$

A) $f(x) = x + 4, g(x) = 1/x^2$

C) $f(x) = 1/x, g(x) = 1/x + 4$

B) $f(x) = 1/x^2, g(x) = 4$

D) $f(x) = x, g(x) = 1/x + 4$

$$4) h(x) = \frac{10}{\sqrt{3x+4}}$$

A) $f(x) = 10/\sqrt{x}, g(x) = 3x + 4$

C) $f(x) = \sqrt{3x+4}, g(x) = 10$

B) $f(x) = 10/x, g(x) = 3x + 4$

D) $f(x) = 10, g(x) = \sqrt{3+4}$

5) $h(x) = (5x + 9)^7$

A) $f(x) = x^7, g(x) = 5x + 9$

C) $f(x) = (5x)^7, g(x) = 9$

B) $f(x) = 5x + 9, g(x) = x^7$

D) $f(x) = 5x^7, g(x) = x + 9$

6) $h(x) = \sqrt{3x^2 + 43}$

A) $f(x) = \sqrt{x}, g(x) = 3x^2 + 43$

C) $f(x) = \sqrt{3x + 43}, g(x) = x^2$

B) $f(x) = 3x^2 + 43, g(x) = \sqrt{x}$

D) $f(x) = \sqrt{3x^2}, g(x) = \sqrt{43}$

2.7 Inverse Functions

1 Verify Inverse Functions

MULTIPLE CHOICE. Choose the one alternative that best completes the statement or answers the question.

Determine which two functions are inverses of each other.

1) $f(x) = 5x$ $g(x) = \frac{x}{5}$ $h(x) = \frac{5}{x}$

A) $f(x)$ and $g(x)$

B) $f(x)$ and $h(x)$

C) $g(x)$ and $h(x)$

D) None

2) $f(x) = \sqrt{x}$ $g(x) = \frac{1}{\sqrt{x}}$ $h(x) = x^2$

A) $f(x)$ and $h(x)$

B) $f(x)$ and $g(x)$

C) $g(x)$ and $h(x)$

D) None

3) $f(x) = \frac{x-2}{3}$ $g(x) = 3x - 2$ $h(x) = \frac{x+2}{3}$

A) $g(x)$ and $h(x)$

B) $f(x)$ and $g(x)$

C) $f(x)$ and $h(x)$

D) None

4) $f(x) = \frac{x-7}{3}$ $g(x) = 3x - 7$ $h(x) = \frac{x-3}{-7}$

A) None

B) $f(x)$ and $g(x)$

C) $f(x)$ and $h(x)$

D) $g(x)$ and $h(x)$

5) $f(x) = x^4 - 5$ $g(x) = \sqrt[4]{x-5}$ $h(x) = x^4 + 5$

A) $g(x)$ and $h(x)$

B) $f(x)$ and $g(x)$

C) $f(x)$ and $h(x)$

D) None

2 Find the Inverse of a Function

MULTIPLE CHOICE. Choose the one alternative that best completes the statement or answers the question.

Find the inverse of the one-to-one function.

1) $f(x) = -4x + 5$

A) $f^{-1}(x) = \frac{x-5}{-4}$

B) $f^{-1}(x) = \frac{x+5}{-4}$

C) $f^{-1}(x) = \frac{y-5}{-4}$

D) $f^{-1}(x) = \frac{-4x-5}{-4}$

2) $f(x) = \frac{6x-7}{5}$

A) $f^{-1}(x) = \frac{5x+7}{6}$

B) $f^{-1}(x) = \frac{5x-7}{6}$

C) $f^{-1}(x) = \frac{5}{6x+7}$

D) $f^{-1}(x) = \frac{5}{6x-7}$

$$3) f(x) = \frac{7}{6x - 5}$$

$$A) f^{-1}(x) = \frac{7}{6x} + \frac{5}{6}$$

$$C) f^{-1}(x) = \frac{6x - 5}{7}$$

$$B) f^{-1}(x) = \frac{7}{6y} + \frac{5}{6}$$

$$D) f^{-1}(x) = -\frac{5}{6} - \frac{7}{6x}$$

$$4) f(x) = (x + 6)^3$$

$$A) f^{-1}(x) = \sqrt[3]{x} - 6$$

$$B) f^{-1}(x) = \sqrt[3]{x} + 6$$

$$C) f^{-1}(x) = \sqrt{x} - 6$$

$$D) f^{-1}(x) = \sqrt[3]{x} - 216$$

$$5) f(x) = \sqrt{x - 7}$$

$$A) f^{-1}(x) = x^2 + 7$$

$$B) f^{-1}(x) = \frac{1}{x^2 + 7}$$

$$C) f^{-1}(x) = x + 7$$

$$D) f^{-1}(x) = x^2 - 7$$

$$6) f(x) = \sqrt[3]{x + 8}$$

$$A) f^{-1}(x) = x^3 - 8$$

$$B) f^{-1}(x) = \frac{1}{x^3 - 8}$$

$$C) f^{-1}(x) = x - 8$$

$$D) f^{-1}(x) = x^3 + 64$$

3 Use the Horizontal Line Test to Determine if a Function has an Inverse Function

MULTIPLE CHOICE. Choose the one alternative that best completes the statement or answers the question.

Does the graph represent a function that has an inverse function?

1)

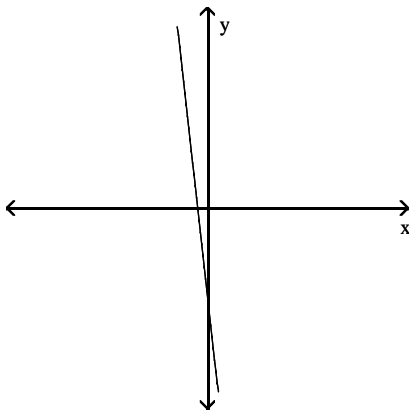

A) Yes

B) No

2)

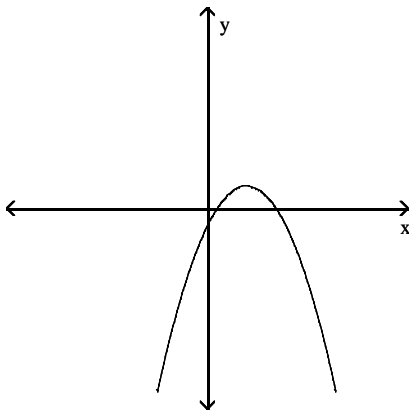

A) No

B) Yes

3)

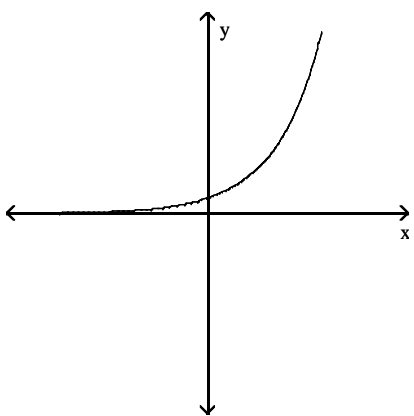

A) Yes

B) No

4)

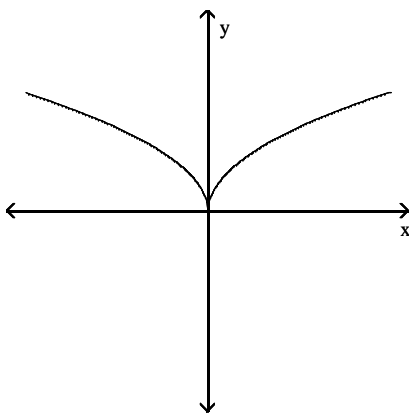

A) No

B) Yes

5)

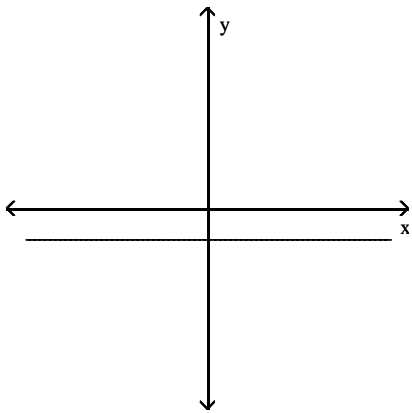

A) No

B) Yes

6)

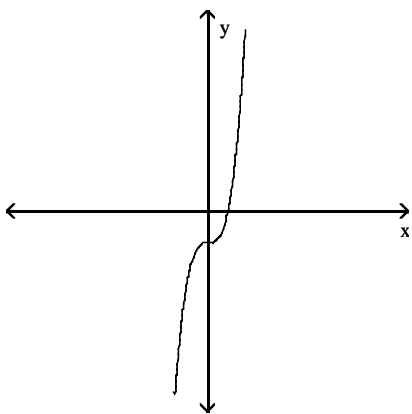

A) Yes

B) No

7)

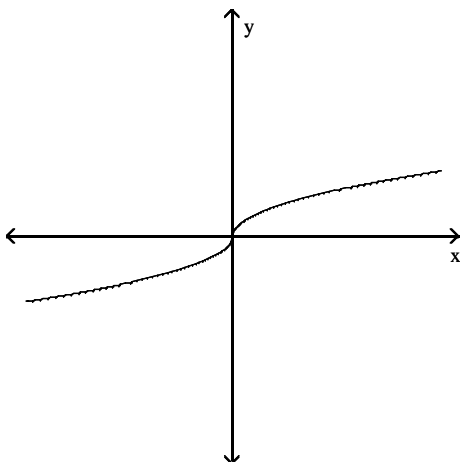

A) Yes

B) No

8)

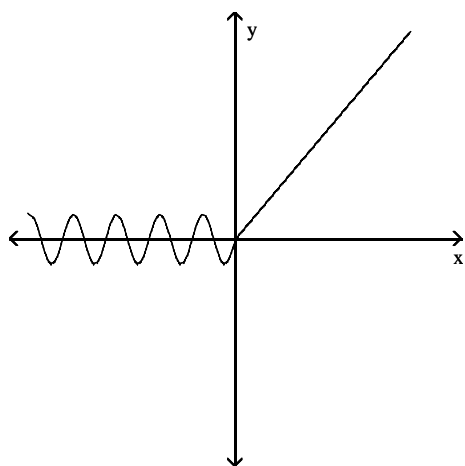

A) No

B) Yes

4 Use the Graph of a One-to-One Function to Graph Its Inverse Function

MULTIPLE CHOICE. Choose the one alternative that best completes the statement or answers the question.

Use the graph of f to draw the graph of its inverse function.

1)

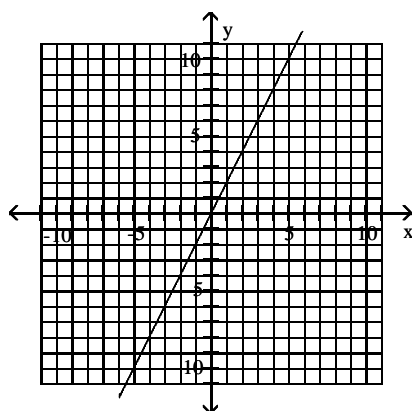

A)

B)

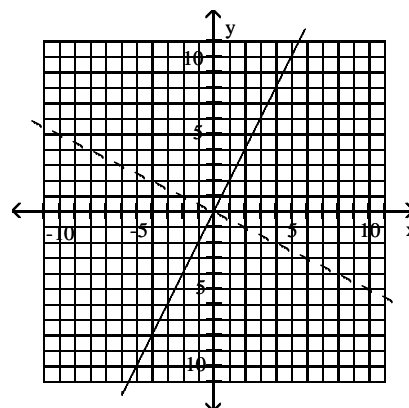
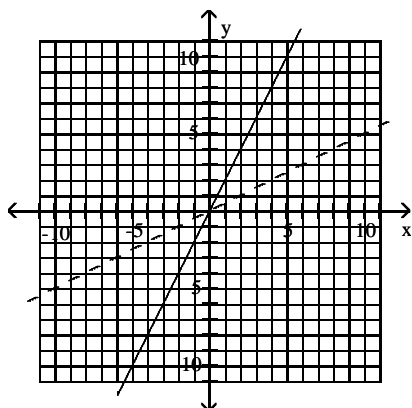

2)

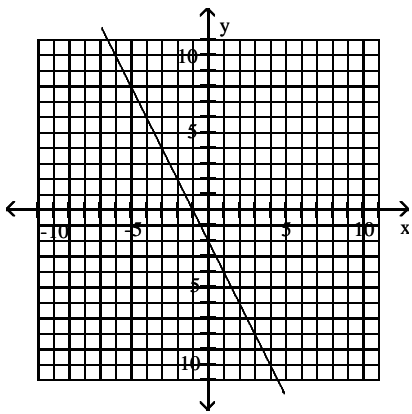

A)

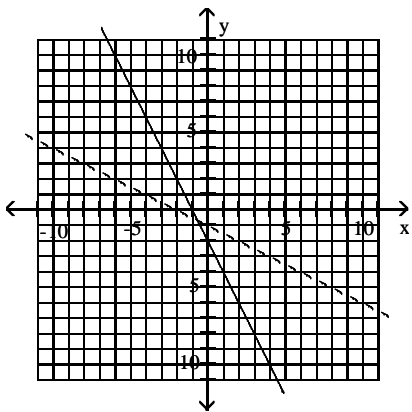

B)

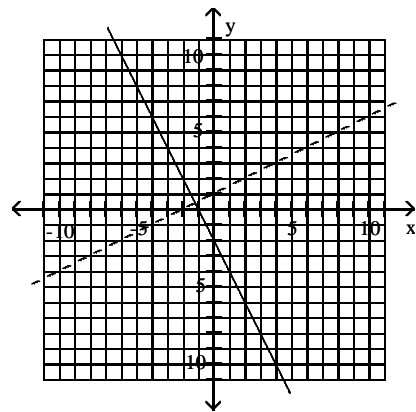

3)

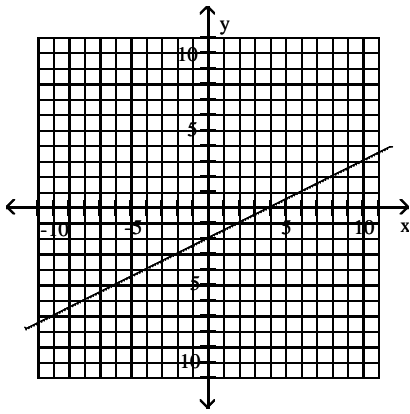

A)

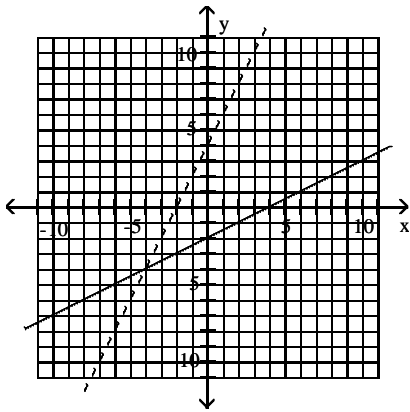

B)

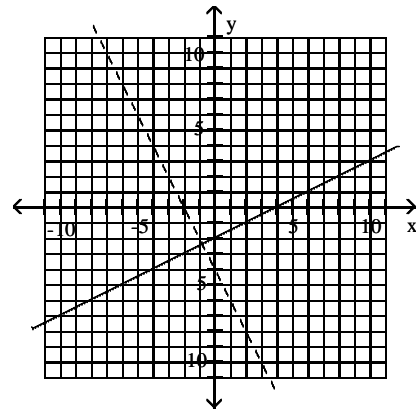

4)

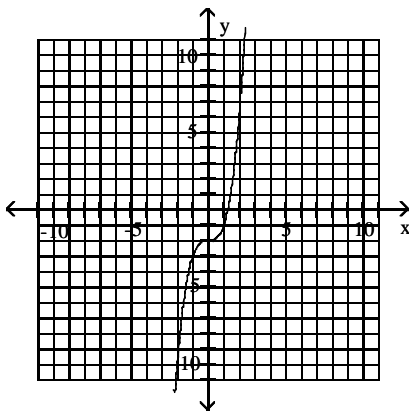

A)

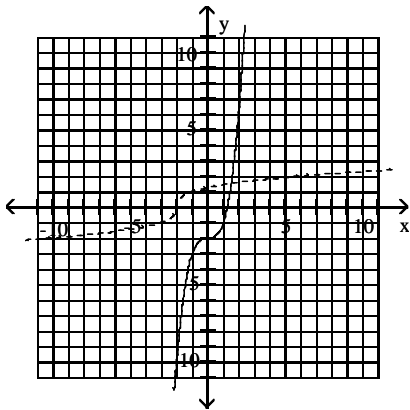

B)

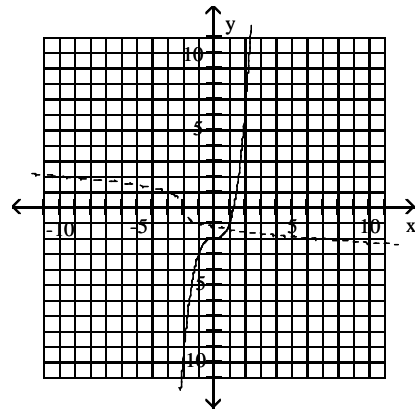

5)

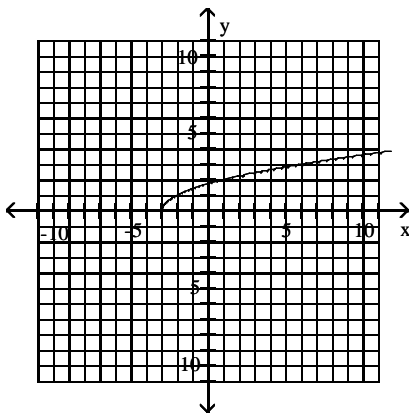

A)

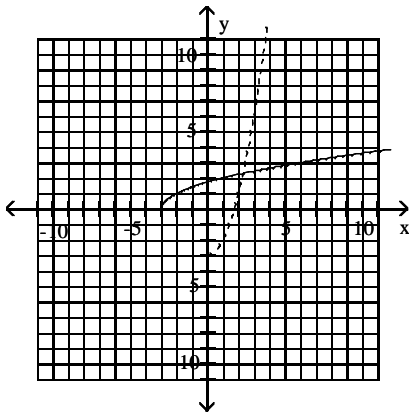

B)

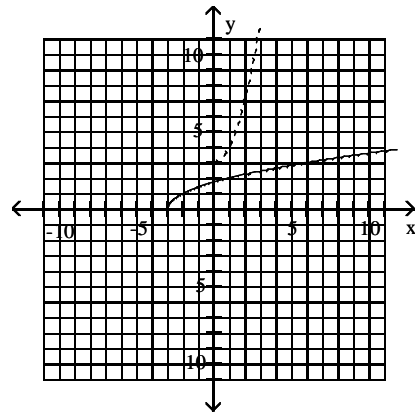

C)

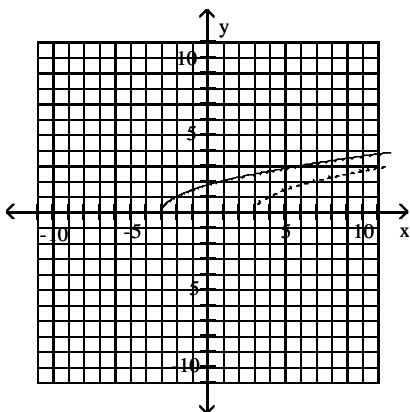

D)

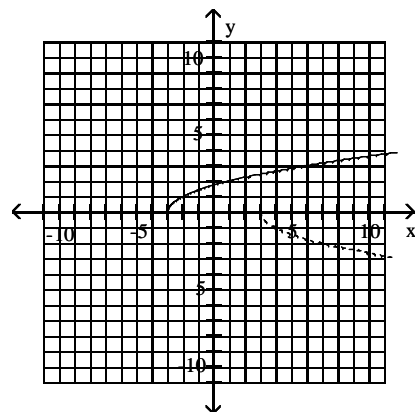

6)

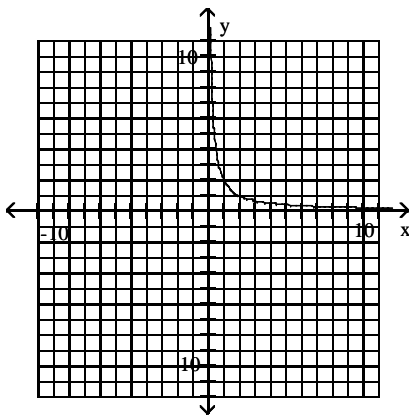

A)

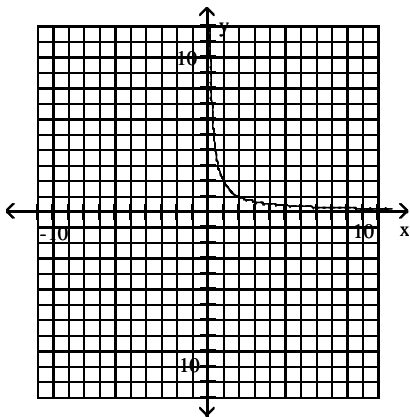

B)

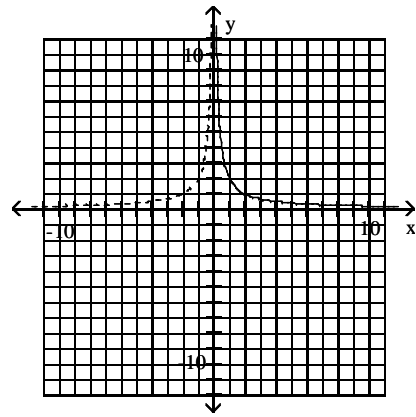

C)

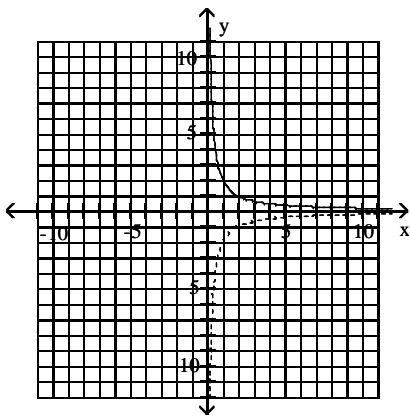

D)

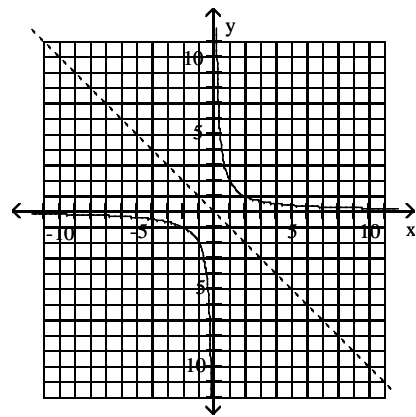

5 Find the Inverse of a Function and Graph Both Functions on the Same Axes

MULTIPLE CHOICE. Choose the one alternative that best completes the statement or answers the question.

Graph f as a solid line and f^{-1} as a dashed line in the same rectangular coordinate space. Use interval notation to give the domain and range of f and f^{-1} .

1) $f(x) = 2x - 3$

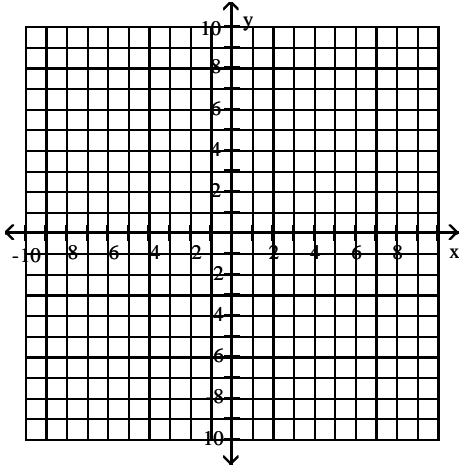

A)

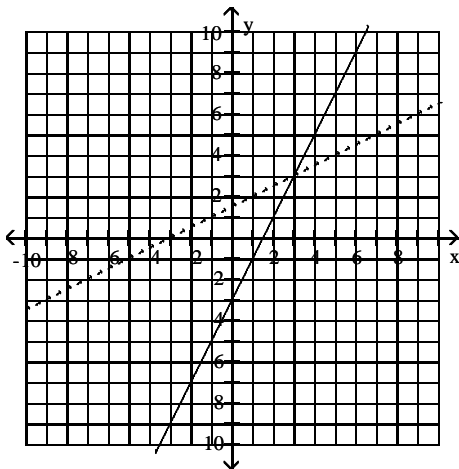

f domain = $(-\infty, \infty)$; range = $(-\infty, \infty)$
 f^{-1} domain = $(-\infty, \infty)$; range = $(-\infty, \infty)$

B)

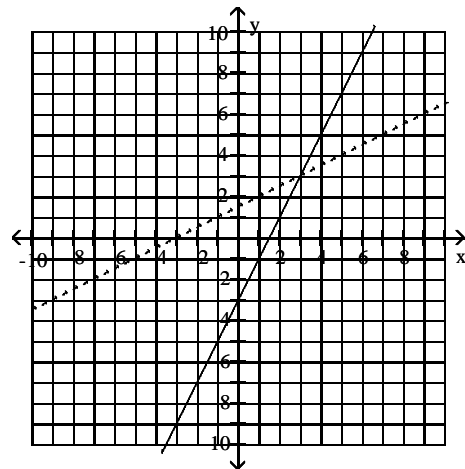

f domain = $(-10, 10)$; range = $(-10, 10)$
 f^{-1} domain = $(-10, 10)$; range = $(-10, 10)$

C)

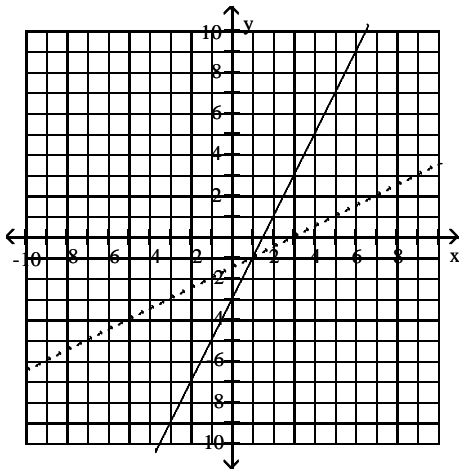

f domain = $(-\infty, \infty)$; range = $(-\infty, \infty)$
 f^{-1} domain = $(-\infty, \infty)$; range = $(-\infty, \infty)$

D)

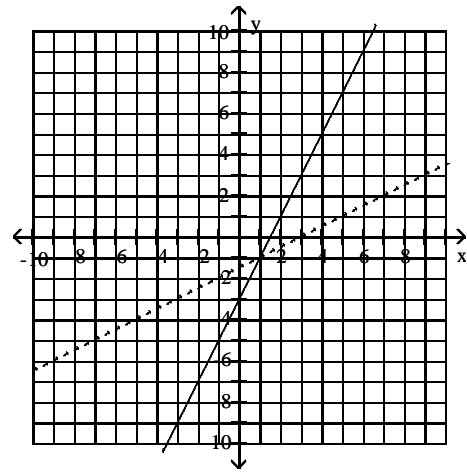

f domain = $(-10, 10)$; range = $(-10, 10)$
 f^{-1} domain = $(-10, 10)$; range = $(-10, 10)$

2) $f(x) = x^2 - 3, x \geq 0$

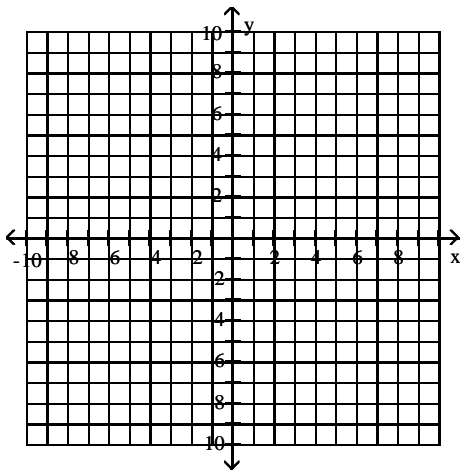

A)

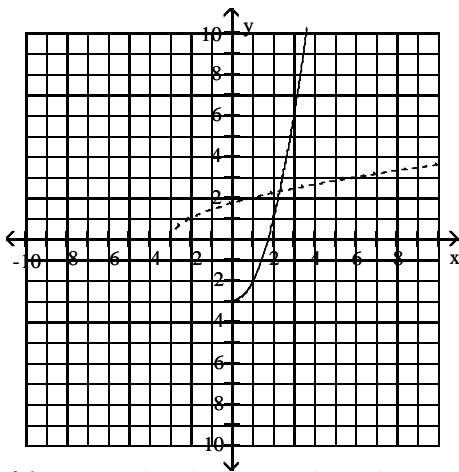

f domain = $(0, \infty)$; range = $(-3, \infty)$
 f^{-1} domain = $(0, \infty)$; range = $(-3, \infty)$

B)

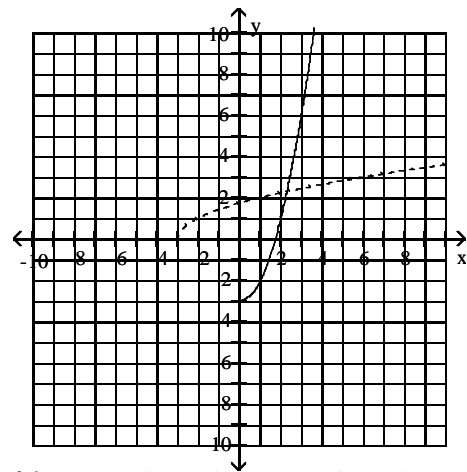

f domain = $(-\infty, \infty)$; range = $(-3, \infty)$
 f^{-1} domain = $(-\infty, \infty)$; range = $(-3, \infty)$

C)

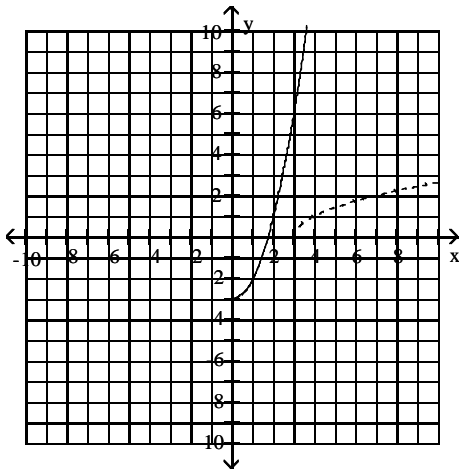

f domain = $(0, \infty)$; range = $(-3, \infty)$
 f^{-1} domain = $(0, \infty)$; range = $(3, \infty)$

D)

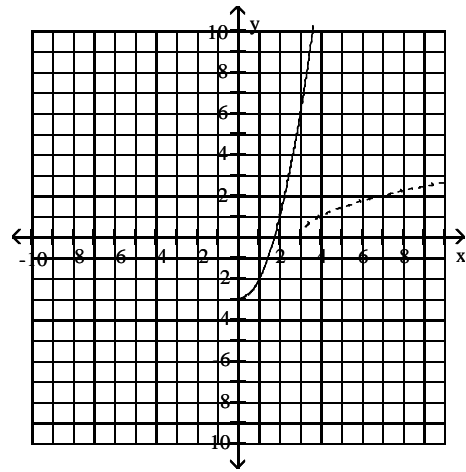

f domain = $(-\infty, \infty)$; range = $(-3, \infty)$
 f^{-1} domain = $(-\infty, \infty)$; range = $(3, \infty)$

3) $f(x) = (x - 1)^2, x \geq 1$

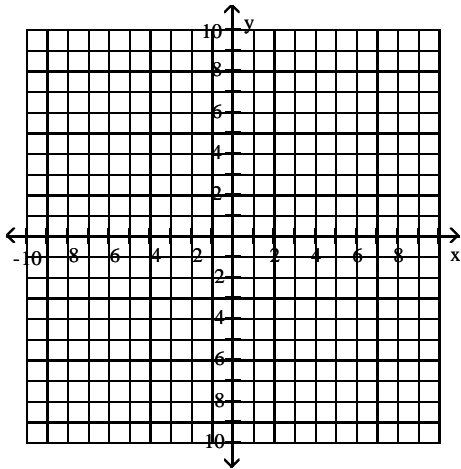

A)

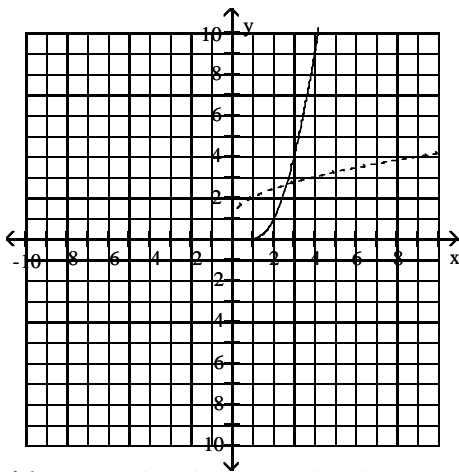

f domain = $(1, \infty)$; range = $(0, \infty)$
 f^{-1} domain = $(0, \infty)$; range = $(1, \infty)$

B)

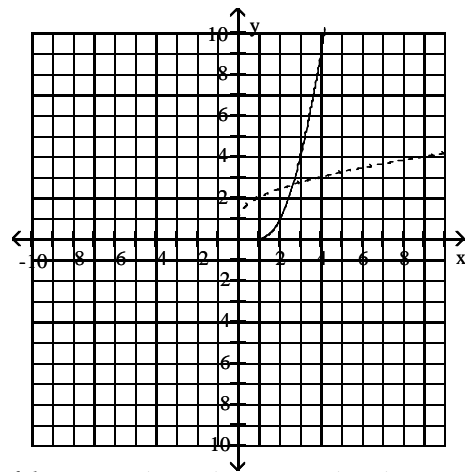

f domain = $(-\infty, \infty)$; range = $(0, \infty)$
 f^{-1} domain = $(0, \infty)$; range = $(-\infty, \infty)$

C)

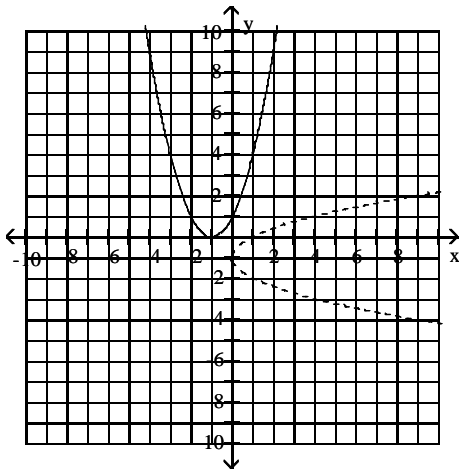

f domain = $(-\infty, \infty)$; range = $(0, \infty)$
 f^{-1} domain = $(0, \infty)$; range = $(-\infty, \infty)$

D)

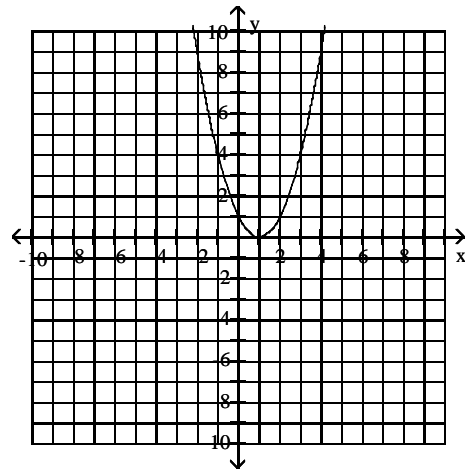

Has no inverse
 f domain = $(-\infty, \infty)$; range = $(0, \infty)$

4) $f(x) = x^3 - 6$

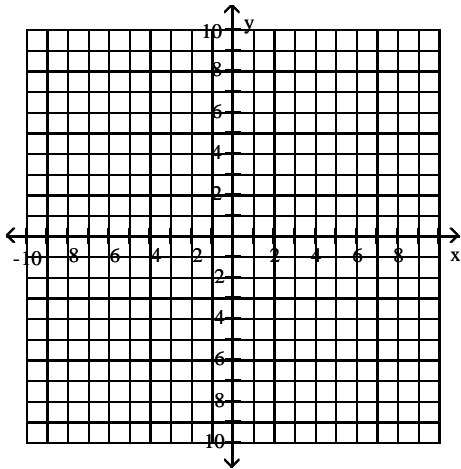

A)

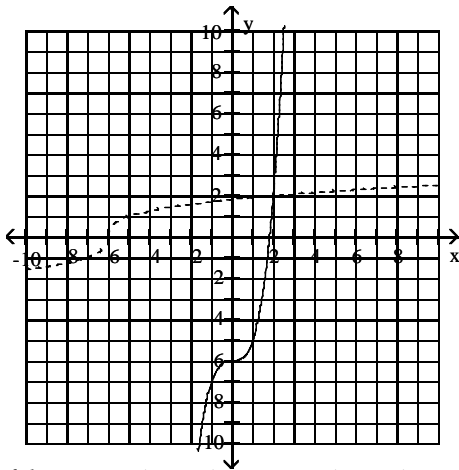

f domain = $(-\infty, \infty)$; range = $(-\infty, \infty)$
 f^{-1} domain = $(-\infty, \infty)$; range = $(-\infty, \infty)$

B)

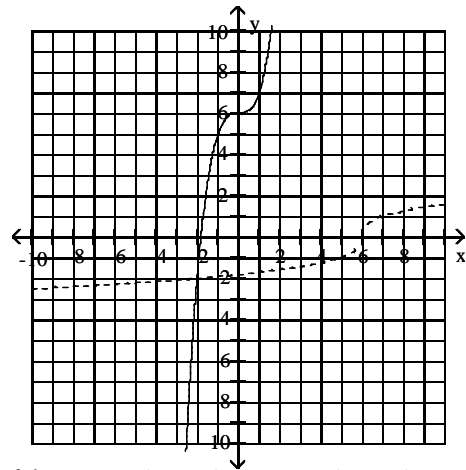

f domain = $(-\infty, \infty)$; range = $(-\infty, \infty)$
 f^{-1} domain = $(-\infty, \infty)$; range = $(-\infty, \infty)$

C)

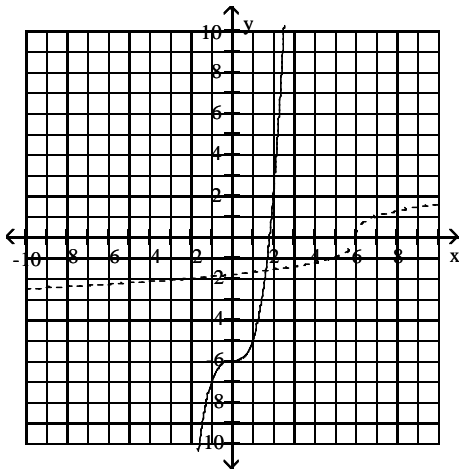

f domain = $(-\infty, \infty)$; range = $(-\infty, \infty)$
 f^{-1} domain = $(-\infty, \infty)$; range = $(-\infty, \infty)$

D)

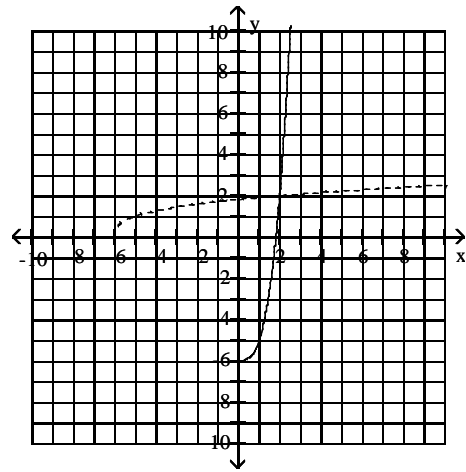

f domain = $(0, \infty)$; range = $(-6, \infty)$
 f^{-1} domain = $(-6, \infty)$; range = $(0, \infty)$

5) $f(x) = (x + 6)^3$

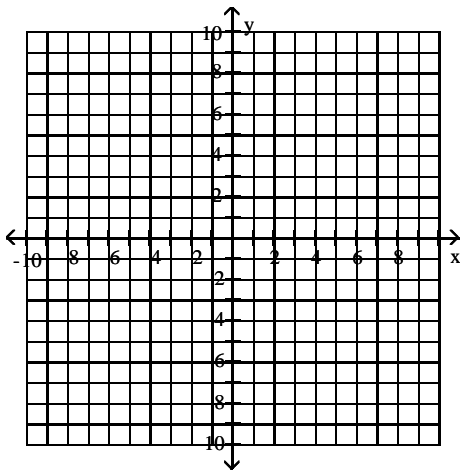

A)

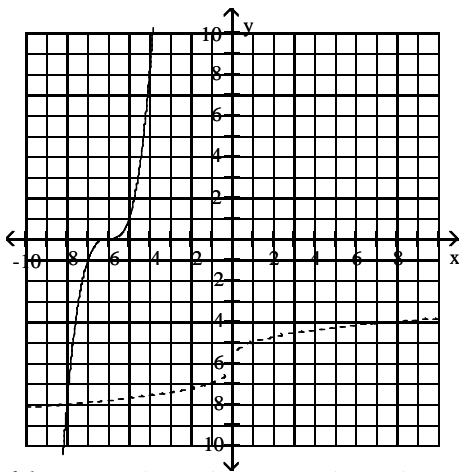

f domain = $(-\infty, \infty)$; range = $(-\infty, \infty)$
 f^{-1} domain = $(-\infty, \infty)$; range = $(-\infty, \infty)$

B)

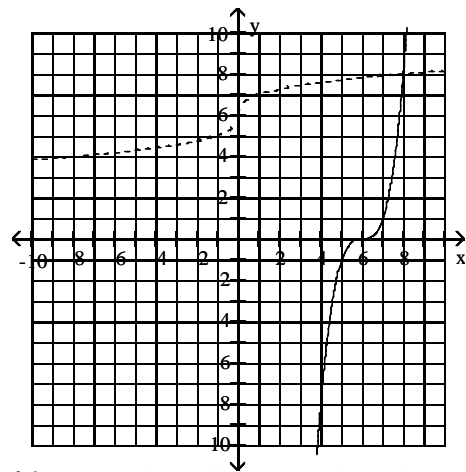

f domain = $(-\infty, \infty)$; range = $(-\infty, \infty)$
 f^{-1} domain = $(-\infty, \infty)$; range = $(-\infty, \infty)$

C)

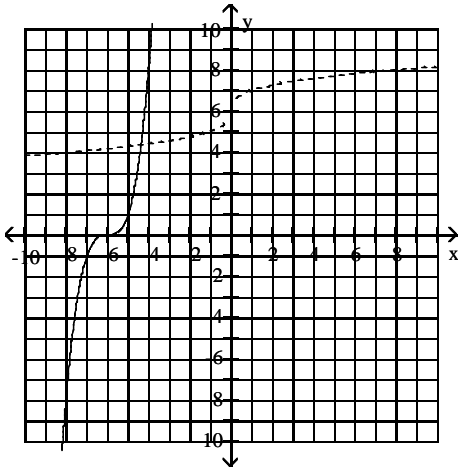

f domain = $(-\infty, \infty)$; range = $(-\infty, \infty)$
 f^{-1} domain = $(-\infty, \infty)$; range = $(-\infty, \infty)$

D)

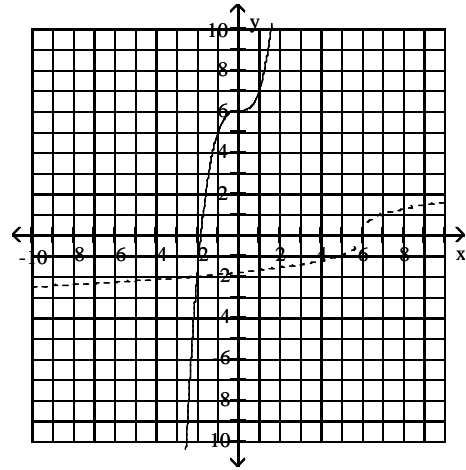

f domain = $(-\infty, \infty)$; range = $(-\infty, \infty)$
 f^{-1} domain = $(-\infty, \infty)$; range = $(-\infty, \infty)$

6) $f(x) = \sqrt{x-5}$

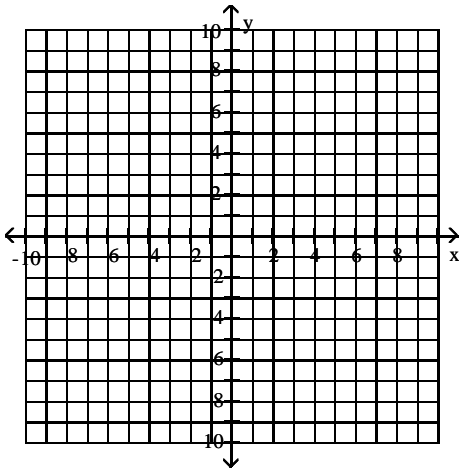

A)

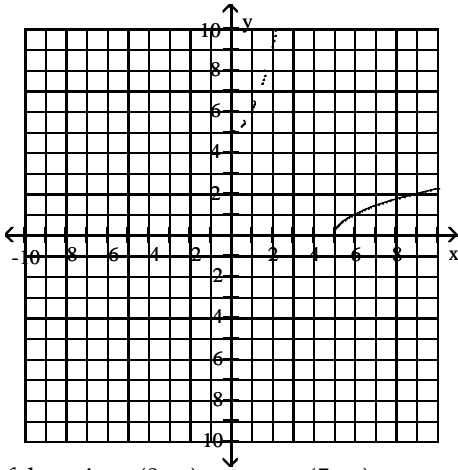

f domain = $(0, \infty)$; range = $(5, \infty)$
 f^{-1} domain = $(5, \infty)$; range = $(0, \infty)$

B)

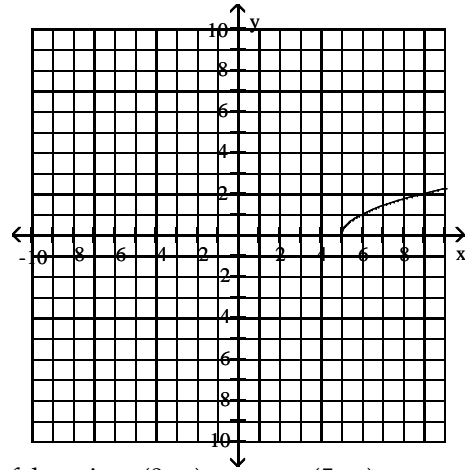

f domain = $(0, \infty)$; range = $(5, \infty)$
 f^{-1} Has no inverse.

C)

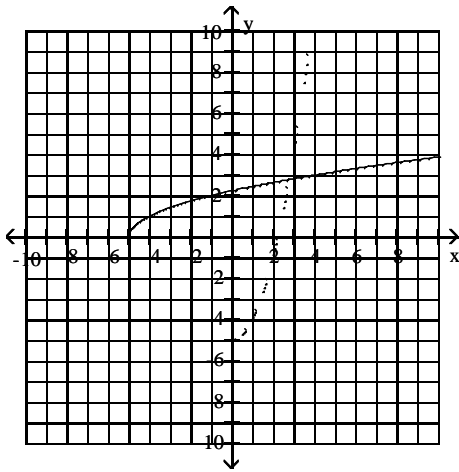

f domain = $(0, \infty)$; range = $(-5, \infty)$
 f^{-1} domain = $(-5, \infty)$; range = $(0, \infty)$

D)

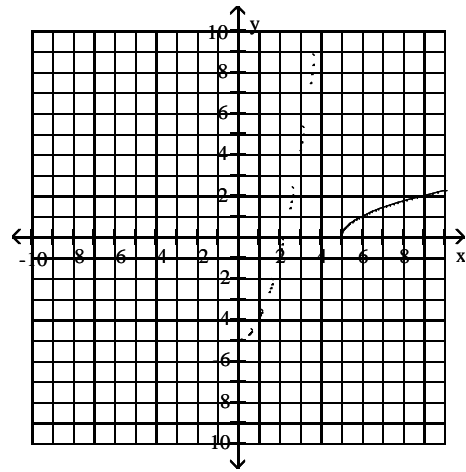

f domain = $(0, \infty)$; range = $(5, \infty)$
 f^{-1} domain = $(-5, \infty)$; range = $(0, \infty)$

7) $f(x) = \sqrt[3]{x} + 4$

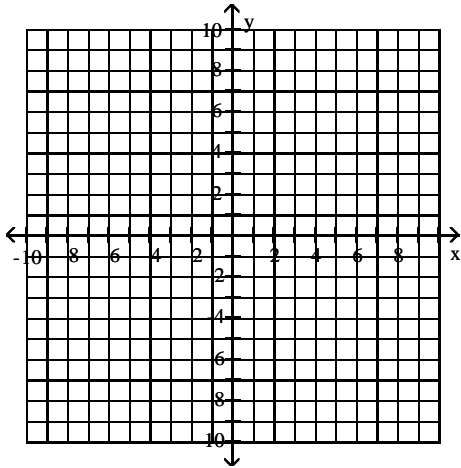

A)

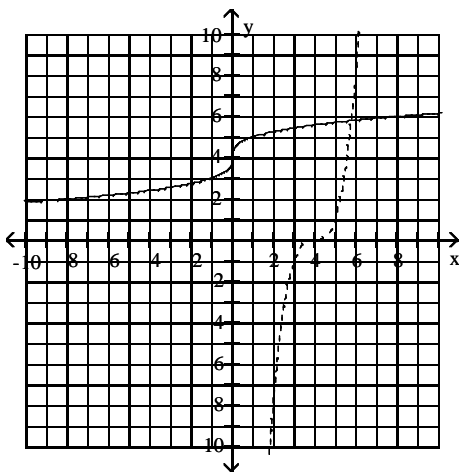

f domain = $(-\infty, \infty)$; range = $(-\infty, \infty)$
 f^{-1} domain = $(-\infty, \infty)$; range = $(-\infty, \infty)$

B)

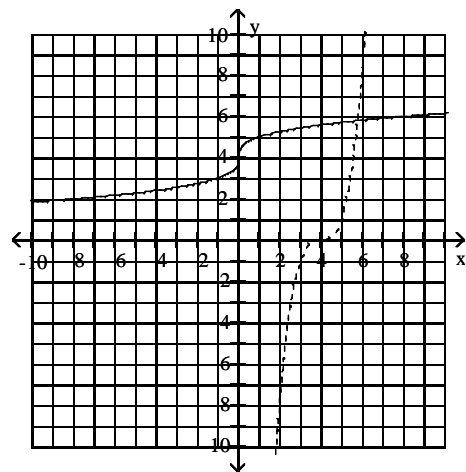

f domain = $(-\infty, \infty)$; range = $(0, \infty)$
 f^{-1} domain = $(0, \infty)$; range = $(-\infty, \infty)$

C)

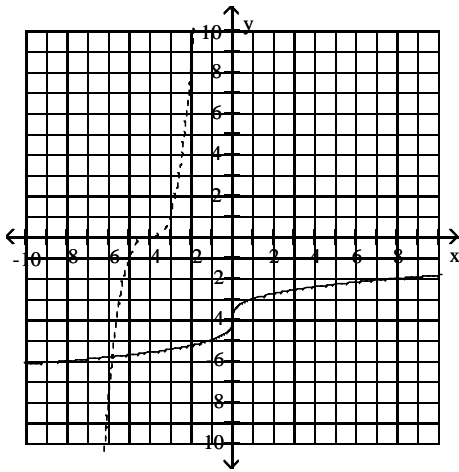

f domain = $(-\infty, \infty)$; range = $(-\infty, \infty)$
 f^{-1} domain = $(-\infty, \infty)$; range = $(-\infty, \infty)$

D)

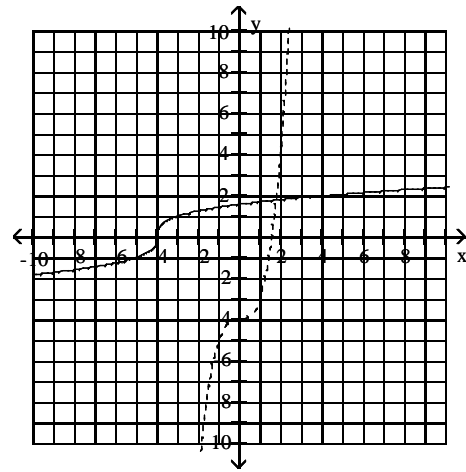

f domain = $(-\infty, \infty)$; range = $(-\infty, \infty)$
 f^{-1} domain = $(-\infty, \infty)$; range = $(-\infty, \infty)$

2.8 Distance and Midpoint Formulas; Circles

1 Find the Distance Between Two Points

MULTIPLE CHOICE. Choose the one alternative that best completes the statement or answers the question.

Find the distance between the pair of points.

1) $(-1, 4)$ and $(-5, 7)$

A) 5

B) 25

C) 6

D) 10

2) $(7, 1)$ and $(-2, -3)$

A) $\sqrt{97}$

B) $\sqrt{65}$

C) 36

D) 5

3) $(2, -1)$ and $(6, -3)$

A) $2\sqrt{5}$

B) $12\sqrt{3}$

C) 12

D) 6

4) $(-7, -5)$ and $(5, -3)$

A) $2\sqrt{37}$

B) $140\sqrt{35}$

C) 140

D) 10

5) $(6, 1)$ and $(7, -6)$

A) $5\sqrt{2}$

B) $48\sqrt{3}$

C) 48

D) 8

6) $(3\sqrt{7}, -2)$ and $(6\sqrt{7}, -1)$

A) 8

B) 64

C) 7

D) 32

7) $(0, 0)$ and $(-4, 7)$

A) $\sqrt{65}$

B) 65

C) 3

D) $\sqrt{11}$

8) $(0, -2)$ and $(7, -2)$

A) 7

B) 2

C) $\sqrt{53}$

D) 49

2 Find the Midpoint of a Line Segment

MULTIPLE CHOICE. Choose the one alternative that best completes the statement or answers the question.

Find the midpoint of the line segment whose end points are given.

1) (7, 3) and (4, 1)

A) $(\frac{11}{2}, 2)$

B) $(\frac{3}{2}, 1)$

C) (3, 2)

D) (11, 4)

2) (-2, -2) and (2, 2)

A) (0, 0)

B) (-2, -2)

C) (-4, -4)

D) (0, 0)

3) $(-\frac{8}{3}, \frac{8}{3})$ and (-2, 1)

A) $(-\frac{7}{3}, \frac{11}{6})$

B) $(-\frac{1}{3}, \frac{5}{6})$

C) $(-\frac{14}{3}, \frac{11}{3})$

D) $(\frac{1}{3}, -\frac{5}{6})$

4) $(-9\sqrt{2}, -5\sqrt{6})$ and $(-4\sqrt{2}, -2\sqrt{6})$

A) $(\frac{-13\sqrt{2}}{2}, \frac{-7\sqrt{6}}{2})$

B) $(\frac{5\sqrt{2}}{2}, \frac{3\sqrt{6}}{2})$

C) $(\frac{-5\sqrt{2}}{2}, \frac{-3\sqrt{6}}{2})$

D) $(-13\sqrt{2}, -7\sqrt{6})$

3 Write the Standard Form of a Circle's Equation

MULTIPLE CHOICE. Choose the one alternative that best completes the statement or answers the question.

Write the standard form of the equation of the circle with the given center and radius.

1) (-4, 4); 3

A) $(x + 4)^2 + (y - 4)^2 = 9$

B) $(x - 4)^2 + (y + 4)^2 = 9$

C) $(x - 4)^2 + (y + 4)^2 = 3$

D) $(x + 4)^2 + (y - 4)^2 = 3$

2) (-1, 0); 9

A) $(x + 1)^2 + y^2 = 81$

B) $(x - 1)^2 + y^2 = 81$

C) $x^2 + (y + 1)^2 = 9$

D) $x^2 + (y - 1)^2 = 9$

3) (0, -1); 5

A) $x^2 + (y + 1)^2 = 25$

B) $x^2 + (y - 1)^2 = 5$

C) $(x + 1)^2 + y^2 = 25$

D) $(x - 1)^2 + y^2 = 25$

4) (-3, 1); $\sqrt{7}$

A) $(x + 3)^2 + (y - 1)^2 = 7$

B) $(x - 3)^2 + (y + 1)^2 = 7$

C) $(x - 1)^2 + (y + 3)^2 = 49$

D) $(x + 1)^2 + (y - 3)^2 = 49$

5) (0, 5); $\sqrt{13}$

A) $x^2 + (y - 5)^2 = 13$

B) $x^2 + (y + 5)^2 = 13$

C) $(x - 5)^2 + y^2 = 169$

D) $(x + 5)^2 + y^2 = 169$

6) (0, 0); 14

A) $x^2 + y^2 = 196$

B) $x^2 + y^2 = 14$

C) $x^2 + y^2 = 28$

D) $x^2 - y^2 = 14$

7) $(0, 0); \sqrt{3}$

A) $x^2 + y^2 = 3$

B) $x^2 + y^2 = \sqrt{3}$

C) $x^2 + y^2 = 1.5$

D) $x^2 + y^2 = 9$

4 Give the Center and Radius of a Circle Whose Equation is in Standard Form

MULTIPLE CHOICE. Choose the one alternative that best completes the statement or answers the question.

Find the center and the radius of the circle.

1) $(x - 5)^2 + (y + 7)^2 = 36$

A) $(5, -7), r = 6$

B) $(-7, 5), r = 6$

C) $(-5, 7), r = 36$

D) $(7, -5), r = 36$

Graph the equation and state its domain and range. Use interval notation

2) $x^2 + y^2 = 64$

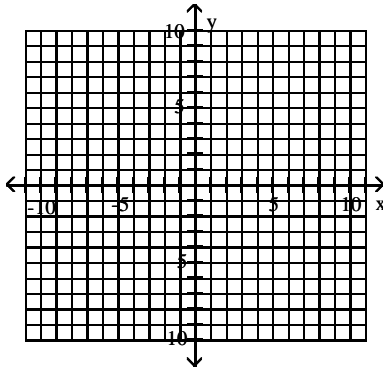

A)

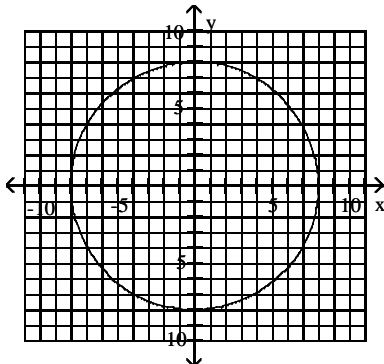

Domain = $(-8, 8)$; Range = $(-8, 8)$

B)

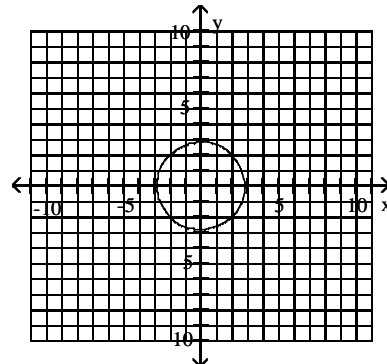

Domain = $(-2\sqrt{2}, 2\sqrt{2})$; Range = $(-2\sqrt{2}, 2\sqrt{2})$

Graph the equation.

3) $(x - 1)^2 + (y - 2)^2 = 49$

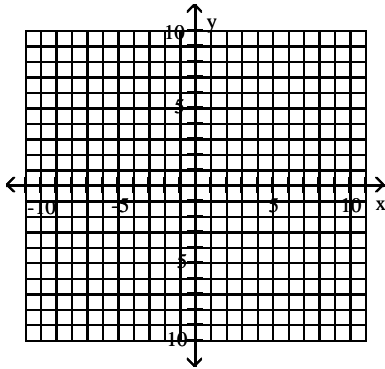

A)

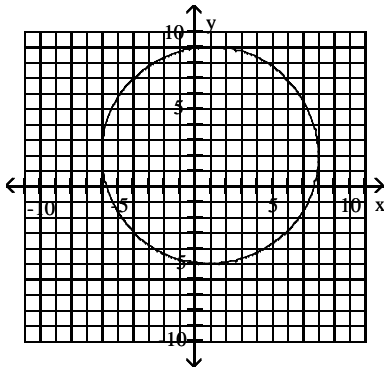

Domain = $(-6, 8)$, Range = $(-5, 9)$

B)

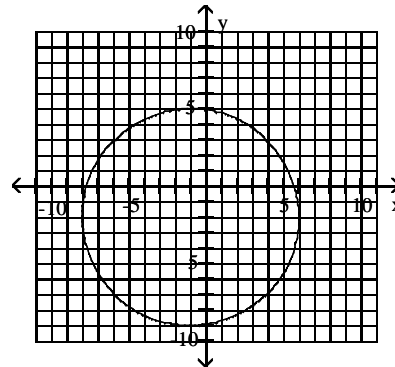

Domain = $(-8, 6)$, Range = $(-9, 5)$

5 Convert the General Form of a Circle's Equation to Standard Form

MULTIPLE CHOICE. Choose the one alternative that best completes the statement or answers the question.

Complete the square and write the equation in standard form. Then give the center and radius of the circle.

1) $x^2 - 10x + 25 + y^2 - 4y + 4 = 36$

A) $(x - 5)^2 + (y - 2)^2 = 36$
 $(5, 2), r = 6$

B) $(x - 2)^2 + (y - 5)^2 = 36$
 $(2, 5), r = 6$

C) $(x - 5)^2 + (y - 2)^2 = 36$
 $(-5, -2), r = 36$

D) $(x - 2)^2 + (y - 5)^2 = 36$
 $(-2, -5), r = 36$

2) $x^2 + y^2 - 12x + 6y + 45 = 9$

A) $(x - 6)^2 + (y + 3)^2 = 9$
 $(6, -3), r = 3$

B) $(x + 3)^2 + (y - 6)^2 = 9$
 $(-3, 6), r = 3$

C) $(x - 6)^2 + (y + 3)^2 = 9$
 $(-6, 3), r = 9$

D) $(x + 3)^2 + (y - 6)^2 = 9$
 $(3, -6), r = 9$

3) $x^2 + y^2 + 16x - 2y = -29$

A) $(x + 8)^2 + (y - 1)^2 = 36$
 $(-8, 1), r = 6$

B) $(x - 1)^2 + (y + 8)^2 = 36$
 $(1, -8), r = 6$

C) $(x + 8)^2 + (y - 1)^2 = 36$
 $(8, -1), r = 36$

D) $(x - 1)^2 + (y + 8)^2 = 36$
 $(-1, 8), r = 36$

4) $14x^2 + 14y^2 = 196$

A) $x^2 + y^2 = 14$
 $(0, 0), r = \sqrt{14}$

C) $x^2 + y^2 = 196$
 $(0, 0), r = 14$

B) $x^2 + y^2 = 14$
 $(0, 0), r = 14$

D) $(x - 14)^2 + (y - 14)^2 = 14$
 $(14, 14), r = \sqrt{14}$

5) $x^2 + y^2 - 10x + 2y + 17 = 0$

A) $(x - 5)^2 + (y + 1)^2 = 9$
 $(5, -1), r = 3$

C) $(x - 5)^2 + (y + 1)^2 = 9$
 $(-5, 1), r = 3$

B) $(x - 5)^2 + (y + 1)^2 = 9$
 $(5, -1), r = 9$

D) $(x + 5)^2 + (y - 1)^2 = 9$
 $(-5, 1), r = 3$

Graph the equation.

6) $x^2 + y^2 - 4x - 12y + 36 = 0$

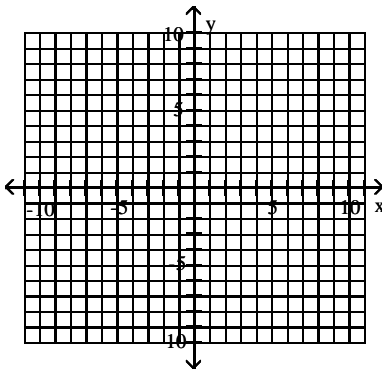

A)

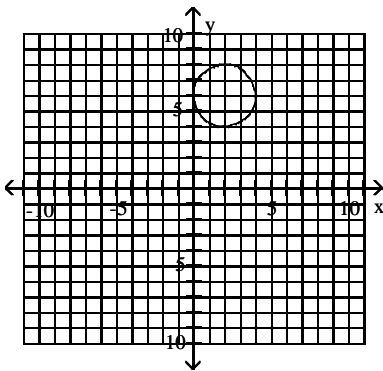

B)

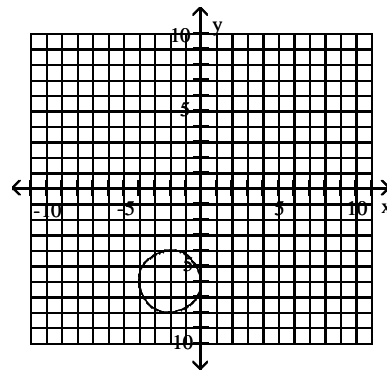

$$7) x^2 + y^2 + 10x + 6y + 30 = 0$$

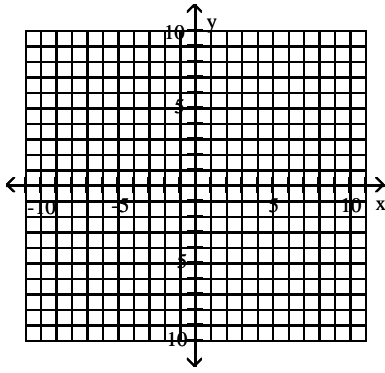

A)

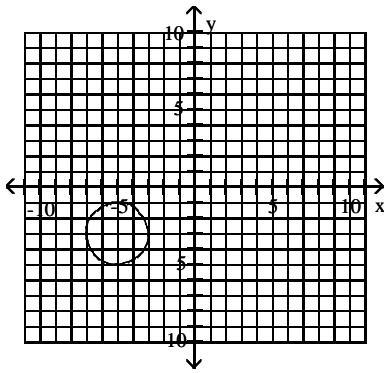

B)

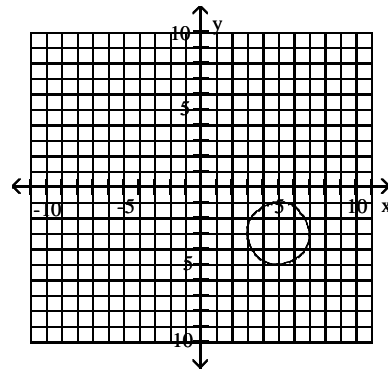

Ch. 2 Functions and Graphs

Answer Key

2.1 Basics of Functions and Their Graphs

1 Find the Domain and Range of a Relation

- 1) A
- 2) A
- 3) A
- 4) A
- 5) A
- 6) A
- 7) A

2 Determine Whether a Relation is a Function

- 1) A
- 2) A
- 3) A
- 4) A
- 5) A
- 6) A
- 7) A
- 8) A
- 9) A
- 10) A

3 Determine Whether an Equation Represents a Function

- 1) A
- 2) A
- 3) A
- 4) B
- 5) B
- 6) B
- 7) B
- 8) A
- 9) A
- 10) A
- 11) A
- 12) A
- 13) A

4 Evaluate a Function

- 1) A
- 2) A
- 3) A
- 4) A
- 5) A
- 6) A
- 7) A
- 8) A
- 9) A
- 10) A

5 Graph Functions by Plotting Points

- 1) A
- 2) A
- 3) A
- 4) A
- 5) A

- 6) A
- 7) A
- 8) A
- 9) A
- 10) A
- 11) A
- 12) A

6 Use the Vertical Line Test to Identify Functions

- 1) A
- 2) A
- 3) A
- 4) A
- 5) A
- 6) A
- 7) A
- 8) A
- 9) A
- 10) A
- 11) A
- 12) A
- 13) A

7 Obtain Information About a Function from Its Graph

- 1) A
- 2) A
- 3) A
- 4) A
- 5) A
- 6) A
- 7) A
- 8) A
- 9) A

8 Identify the Domain and Range of a Function from Its Graph

- 1) A
- 2) A
- 3) A
- 4) A
- 5) A

9 Identify Intercepts from a Function's Graph.

- 1) A
- 2) A
- 3) A
- 4) A
- 5) A
- 6) A

2.2 More on Functions and Their Graphs

1 Identify Intervals on Which a Function Increases, Decreases, or is Constant

- 1) A
- 2) A
- 3) A
- 4) A
- 5) A
- 6) A
- 7) A
- 8) A

- 9) A
- 10) A

2 Use Graphs to Locate Relative Maxima or Minima

- 1) A
- 2) A
- 3) A
- 4) A

3 Identify Even or Odd Functions and Recognize Their Symmetries

- 1) A
- 2) A
- 3) A
- 4) A
- 5) A
- 6) A
- 7) A
- 8) A

4 Understand and Use Piecewise Functions

- 1) A
- 2) A
- 3) A
- 4) A
- 5) A
- 6) A
- 7) A
- 8) A
- 9) A
- 10) A
- 11) A
- 12) A

- 13) \$25.52
- \$42.69

$$C(x) = \begin{cases} 8.8 + 0.6686x & \text{if } 0 \leq x \leq 25 \\ 25.515 + 0.133219(x - 25) & \text{if } x > 25 \end{cases}$$

- 14) \$39.70
- \$49.69

$$C(x) = \begin{cases} 4.93 + 0.11589x & \text{if } 0 \leq x \leq 300 \\ 39.697 + 0.13321(x - 300) & \text{if } x > 300 \end{cases}$$

- 15) \$18.00
- \$24.25
- \$65.50

- 16) 6.0°C
- 17) \$27.50

$$C(x) = \begin{cases} 20 & \text{if } 0 \leq x \leq 100 \\ 20 + 0.075(x - 100) & \text{if } 100 < x \leq 200 \\ 27.50 + 0.1(x - 200) & \text{if } x > 200 \end{cases}$$

5 Find and Simplify a Function's Difference Quotient

- 1) A
- 2) A
- 3) A
- 4) A
- 5) A

2.3 Linear Functions and Slope

1 Calculate a Line's Slope

- 1) A
- 2) A
- 3) A
- 4) A
- 5) A
- 6) A
- 7) A
- 8) A

2 Write the Point-Slope Form of the Equation of a Line

- 1) A
- 2) A
- 3) A
- 4) A
- 5) A
- 6) A

3 Write and Graph the Slope-Intercept Form of the Equation of a Line

- 1) A
- 2) A
- 3) A
- 4) A
- 5) A
- 6) A
- 7) A
- 8) A
- 9) A
- 10) A
- 11) A

4 Graph Horizontal or Vertical Lines

- 1) A
- 2) A
- 3) A
- 4) A
- 5) A
- 6) A
- 7) A

5 Recognize and Use the General Form of a Line's Equation

- 1) A
- 2) A
- 3) A
- 4) A
- 5) A
- 6) A
- 7) A
- 8) A
- 9) A
- 10) A

6 Use Intercepts to Graph the General Form of a Line's Equation

- 1) A
- 2) A
- 3) A
- 4) A
- 5) A

7 Model Data with Linear Functions and Make Predictions

- 1) A
- 2) A
- 3) A
- 4) A
- 5) A
- 6) A
- 7) A
- 8) A
- 9) A
- 10) A

2.4 More on Slope

1 Find Slopes and Equations of Parallel and Perpendicular Lines

- 1) A
- 2) A
- 3) A
- 4) A
- 5) A
- 6) A
- 7) A
- 8) A
- 9) A
- 10) A

2 Interpret Slope as Rate of Change

- 1) A
- 2) A

3 Find a Function's Average Rate of Change

- 1) A
- 2) A
- 3) A
- 4) A
- 5) A
- 6) A

2.5 Transformations of Functions

1 Recognize Graphs of Common Functions

- 1) A
- 2) A
- 3) A
- 4) A
- 5) A
- 6) A

2 Use Vertical Shifts to Graph Functions

- 1) A
- 2) A
- 3) A
- 4) A
- 5) A
- 6) A

3 Use Horizontal Shifts to Graph Functions

- 1) A
- 2) A
- 3) A
- 4) A
- 5) A

6) A

4 Use Reflections to Graph Functions

1) A

2) A

3) A

4) A

5) A

6) A

5 Use Vertical Stretching and Shrinking to Graph Functions

1) A

2) A

3) A

4) A

5) A

6) A

6 Use Horizontal Stretching and Shrinking to Graph Functions

1) A

2) A

3) A

4) A

5) A

7 Graph Functions Involving a Sequence of Transformations

1) A

2) A

3) A

4) A

5) A

6) A

7) A

8) A

9) A

10) A

11) A

12) A

13) A

2.6 Combinations of Functions; Composite Functions

1 Find the Domain of a Function

1) A

2) A

3) A

4) A

5) A

6) A

7) A

8) A

9) A

10) A

11) A

2 Combine Functions Using the Algebra of Functions, Specifying Domains

1) A

2) A

3) A

4) A

5) A

- 6) A
- 7) A
- 8) A
- 9) A
- 10) A
- 11) A
- 12) A
- 13) A
- 14) A
- 15) A
- 16) A
- 17) A

3 Form Composite Functions

- 1) A
- 2) A
- 3) A
- 4) A
- 5) A
- 6) A
- 7) A

4 Determine Domains for Composite Functions

- 1) A
- 2) A
- 3) A
- 4) A
- 5) A
- 6) A

5 Write Functions as Compositions

- 1) A
- 2) A
- 3) A
- 4) A
- 5) A
- 6) A

2.7 Inverse Functions

1 Verify Inverse Functions

- 1) A
- 2) A
- 3) A
- 4) A
- 5) A

2 Find the Inverse of a Function

- 1) A
- 2) A
- 3) A
- 4) A
- 5) A
- 6) A

3 Use the Horizontal Line Test to Determine if a Function has an Inverse Function

- 1) A
- 2) A
- 3) A
- 4) A
- 5) A

- 6) A
- 7) A
- 8) A

4 Use the Graph of a One-to-One Function to Graph Its Inverse Function

- 1) A
- 2) A
- 3) A
- 4) A
- 5) A
- 6) A

5 Find the Inverse of a Function and Graph Both Functions on the Same Axes

- 1) A
- 2) A
- 3) A
- 4) A
- 5) A
- 6) A
- 7) A

2.8 Distance and Midpoint Formulas; Circles

1 Find the Distance Between Two Points

- 1) A
- 2) A
- 3) A
- 4) A
- 5) A
- 6) A
- 7) A
- 8) A

2 Find the Midpoint of a Line Segment

- 1) A
- 2) A
- 3) A
- 4) A

3 Write the Standard Form of a Circle's Equation

- 1) A
- 2) A
- 3) A
- 4) A
- 5) A
- 6) A
- 7) A

4 Give the Center and Radius of a Circle Whose Equation is in Standard Form

- 1) A
- 2) A
- 3) A

5 Convert the General Form of a Circle's Equation to Standard Form

- 1) A
- 2) A
- 3) A
- 4) A
- 5) A
- 6) A
- 7) A