

TEST BANK



SIXTH EDITION
Calculus



Varberg Purcell Rigdon

Ch. 0 Preliminaries

0.1 Real Numbers, Estimation, and Logic

1 Simplify Algebraic Expression

MULTIPLE CHOICE. Choose the one alternative that best completes the statement or answers the question.

Perform the indicated operations and simplify.

1) $(-9 - 7)(-23 - 4)$

A) 432

B) 38

C) -432

D) -38

2) $(-7 - 2)[6 + (4 + 6)]$

A) -144

B) 25

C) -64

D) 21

3) $2[-2 + 2(-5 + 3)]$

A) -12

B) 0

C) -8

D) -4

4) $\frac{\frac{1}{6} \cdot 36 - 10}{7 + \frac{1}{5} \cdot 25}$

A) $-\frac{1}{3}$

B) $\frac{1}{3}$

C) $\frac{4}{3}$

D) -2

5) $\frac{12(-1) - (-6)(-3)}{\frac{2 \cdot -16}{(-4 - 4)}}$

A) $-\frac{15}{2}$

B) $-\frac{21}{2}$

C) $-\frac{3}{2}$

D) Undefined

6) $(3x + 5y)(3x - y)$

A) $9x^2 + 12xy - 5y^2$

B) $6x^2 + 12xy - 5y^2$

C) $9x^2 + 12xy - 5y$

D) $6x^2 + 15xy - 5y^2$

7) $(3x - \frac{3}{5})(2x + \frac{1}{5})$

A) $6x^2 - \frac{3}{5}x - \frac{3}{25}$

B) $6x^2 + 1x - \frac{3}{25}$

C) $6x^2 - \frac{3}{25}x - \frac{3}{25}$

D) $6x^2 - \frac{3}{5}x - \frac{3}{5}$

8) $(2x + y - z)^2$

A) $4x^2 + y^2 + z^2 + 4xy - 4xz - 2yz$

B) $4x^2 + y^2 + z^2$

C) $4x^2 + y^2 + z^2 + 2xy - 2xz - 2yz$

D) $4x^2 + y^2 + z^2 - 2xyz$

9) $(4x - 7)(x - 6)$

A) $4x^2 - 31x + 42$

B) $x^2 + 42x - 31$

C) $4x^2 - 23x + 42$

D) $x^2 - 31x - 23$

- 10) $(8m + 3)^2$
 A) $64m^2 + 48m + 9$ B) $64m^2 + 9$ C) $8m^2 + 48m + 9$ D) $8m^2 + 9$
- 11) $(\sqrt{8} + 5)(\sqrt{8} - 5)$
 A) -17 B) 33 C) $8 - 2\sqrt{5}$ D) 3
- 12) $(\sqrt{13} + \sqrt{10})(\sqrt{13} - \sqrt{10})$
 A) 3 B) 23 C) $13 - 2\sqrt{13}$ D) $13 - 2\sqrt{10}$
- 13) $(\sqrt{5} - \sqrt{2})^2$
 A) $7 - 2\sqrt{10}$ B) $10 - 2\sqrt{10}$ C) $7 + 2\sqrt{10}$ D) $3 - 2\sqrt{10}$
- 14) $\frac{a^2 + 10a + 16}{a + 8}$
 A) $a + 2$ B) $a - 2$ C) $\frac{1}{a - 2}$ D) $\frac{1}{a + 2}$
- 15) $\frac{24x - 8}{9x^3 - 3x^2}$
 A) $\frac{8}{3x^2}$ B) $-\frac{8}{3x}$ C) $\frac{8}{3x}$ D) $\frac{3}{8x^2}$
- 16) $\frac{x^2 + 6x + 8}{x^2 + 9x + 14}$
 A) $\frac{x + 4}{x + 7}$ B) $\frac{6x + 8}{9x + 14}$ C) $\frac{6x + 4}{9x + 7}$ D) $-\frac{x^2 + 6x + 8}{x^2 + 9x + 14}$
- 17) $\frac{8x^2 - 77x + 45}{x - 9}$
 A) $8x - 5$ B) $\frac{8x^2 - 77x + 45}{x - 9}$ C) $8x^2 - 82$ D) $\frac{1}{x - 9}$
- 18) $\frac{3}{y^2 - 3y + 2} + \frac{5}{y^2 - 1}$
 A) $\frac{8y - 7}{(y - 1)(y + 1)(y - 2)}$ B) $\frac{8y - 7}{(y - 1)(y - 2)}$
 C) $\frac{7y - 8}{(y - 1)(y + 1)(y - 2)}$ D) $\frac{30y - 7}{(y - 1)(y + 1)(y - 2)}$
- 19) $\frac{x}{x^2 - 16} - \frac{4}{x^2 + 5x + 4}$
 A) $\frac{x^2 - 3x + 16}{(x - 4)(x + 4)(x + 1)}$ B) $\frac{x^2 + 3x + 16}{(x - 4)(x + 4)(x + 1)}$ C) $\frac{x^2 - 3x + 16}{(x - 4)(x + 4)}$ D) $\frac{x^2 - 3}{(x - 4)(x + 4)(x + 1)}$

$$20) \frac{10}{x^2 + 5x} + \frac{7}{x} + \frac{2}{x + 5}$$

A) $\frac{9}{x}$

B) $\frac{2}{x}$

C) $\frac{7}{x}$

D) $\frac{14}{x}$

$$21) \frac{7x}{x + 1} + \frac{8}{x - 1} - \frac{14}{x^2 - 1}$$

A) $\frac{7x - 6}{x - 1}$

B) $\frac{7x - 6}{x + 1}$

C) $\frac{x + 1}{x - 1}$

D) $\frac{7x}{x - 1}$

2 Properties of Zero

MULTIPLE CHOICE. Choose the one alternative that best completes the statement or answers the question.

Find the value of the expression. If the expression is undefined, state so.

1) $10 \cdot 0$

A) 0

B) 10

C) 1

D) Undefined

2) $\frac{1}{0}$

A) Undefined

B) 0

C) 1

D) 2

3) 0^3

A) 0

B) 1

C) 3

D) Undefined

3 Write Fraction as Decimal

MULTIPLE CHOICE. Choose the one alternative that best completes the statement or answers the question.

Change the rational number to a decimal.

1) $\frac{5}{9}$

A) 0.555555...

B) 0.999999...

C) 0.5

D) 0.505050...

2) $\frac{1}{11}$

A) 0.090909...

B) 0.090090...

C) 0.111111...

D) 0.909090...

4 Write Repeating Decimal as Fraction

MULTIPLE CHOICE. Choose the one alternative that best completes the statement or answers the question.

Change the repeating decimal to the ratio of two integers.

1) 0.222222...

A) $\frac{2}{9}$

B) $\frac{22}{9}$

C) $\frac{4}{9}$

D) $\frac{2}{11}$

2) 0.545454...

A) $\frac{6}{11}$

B) $\frac{6}{9}$

C) $\frac{54}{11}$

D) $\frac{12}{11}$

5 Tech: Decimal Approximation of Irrational Number

MULTIPLE CHOICE. Choose the one alternative that best completes the statement or answers the question.

Use your calculator to find a decimal approximation.

- 1) $(\sqrt{11} + 2)^4$
A) 798.994975 B) 801.574275 C) 788.994975 D) 812.998375
- 2) $\sqrt[4]{4.2} - \sqrt[3]{1.9}$
A) 0.193007 B) 2.536425 C) 0.19039 D) 1.20343
- 3) $(4.97)^{-1/2}$
A) 0.448561 B) 1.694791 C) 0.265106 D) 2.990494
- 4) $\sqrt[3]{7.1\pi^2 + 5} + 2\pi$
A) 10.501731 B) 4.218551 C) 9.225806 D) 11.777656

6 Write Converse and Contrapositive

MULTIPLE CHOICE. Choose the one alternative that best completes the statement or answers the question.

Write the converse and contrapositive of the statement.

- 1) If it rains today, then it will snow tomorrow.
- A) Converse: If it snows tomorrow, then it will rain today.
Contrapositive: If it does not snow tomorrow, then it will not rain today.
- B) Converse: If it snows tomorrow, then it will rain today.
Contrapositive: If it does not rain today, then it will not snow tomorrow.
- C) Converse: If it does not snow tomorrow, then it will not rain today.
Contrapositive: If it snows tomorrow, then it will rain today.
- D) Converse: If it snows tomorrow, then it will not rain today.
Contrapositive: If it does not snow tomorrow, then it will rain today.
- 2) If angle ABC is obtuse, then its measure is greater than 90° and less than 180° .
- A) Converse: If the measure of angle ABC is greater than 90° and less than 180° , then it is obtuse.
Contrapositive: If the measure of angle ABC is not greater than 90° and less than 180° , then it is not obtuse.
- B) Converse: If the measure of angle ABC is not greater than 90° and less than 180° , then it is not obtuse.
Contrapositive: If the measure of angle ABC is greater than 90° and less than 180° , then it is obtuse.
- C) Converse: If the measure of angle ABC is greater than 90° and less than 180° , then it is obtuse.
Contrapositive: If angle ABC is not obtuse, then its measure is not greater than 90° and less than 180° .
- D) Converse: If angle ABC is not obtuse, then its measure is not greater than 90° and less than 180° .
Contrapositive: If the measure of angle ABC is not greater than 90° and less than 180° , then it is not obtuse.

3) If $a > b$ then $a^2 > b^2$.

- A) Converse: If $a^2 > b^2$ then $a > b$.
Contrapositive: If $a^2 \neq b^2$ then $a \neq b$.
C) Converse: If $a^2 \neq b^2$ then $a > b$.
Contrapositive: If $a^2 > b^2$ then $a \neq b$.

- B) Converse: If $a^2 \neq b^2$ then $a \neq b$.
Contrapositive: If $a^2 > b^2$ then $a > b$.
D) Converse: If $a^2 > b^2$ then $a > b$.
Contrapositive: If $a \neq b$ then $a^2 \geq b^2$.

7 * Logic and Proof

MULTIPLE CHOICE. Choose the one alternative that best completes the statement or answers the question.

Provide an appropriate response.

- 1) Use the rules regarding the negation of statements involving quantifiers to write the negation of the statement:
There is an integer that is not a real number.
A) All integers are real numbers. B) There is an integer that is a real number.
C) All real numbers are integers. D) Most integers are real numbers.
- 2) Use the rules regarding the negation of statements involving quantifiers to write the negation of the statement:
All integers are real numbers.
A) There is an integer that is not a real number. B) All real numbers are not integers.
C) There are integers that are not real numbers. D) All integers are not real numbers.
- 3) Use the rules regarding the negation of statements involving quantifiers to write the negation of the statement:
Every real number is less than its square.
A) There is a real number that is greater than or equal to its square.
B) Every real number is not less than its square.
C) There is a real number that is greater than its square.
D) Every real number is not greater than its square.
- 4) Use the rules regarding the negation of statements involving quantifiers to write the negation of the statement:
There is a real number that is greater than or equal to its square.
A) Every real number is less than its square.
B) There is not a real number that is greater than or equal to its square.
C) Every real number is less than or equal to its square.
D) There is a real number that is not greater than or equal to its square.

SHORT ANSWER. Write the word or phrase that best completes each statement or answers the question.

- 5) Determine if the following statement is true or false. Explain your answer.
For every real number x , $x < 0 \Rightarrow x^2 > 0$.
- 6) Determine if the following statement is true or false. Explain your answer.
For every real number x , $x < 0 \Rightarrow x^2 < 0$.

7) Determine if the following statement is true or false. Explain your answer.

For every real number $x > 0$, there exists a real number y such that $y < \frac{1}{x}$.

8 Find Least Upper Bound

MULTIPLE CHOICE. Choose the one alternative that best completes the statement or answers the question.

Find the least upper bound for the set S.

1) $\{-6, -5, -4, -3, -2\}$

A) -2

B) -1

C) -3

D) -6

2) $\{4.7, 4.79, 4.799, 4.7999, 4.79999, \dots\}$

A) 4.8

B) 4.7

C) 4.799999

D) 4.9

3) $\left\{8 - \frac{1}{5}, 8 - \frac{1}{3}, 8 - \frac{1}{4}, 8 - \frac{1}{5}, \dots\right\}$

A) 8

B) 9

C) 0

D) $8\frac{1}{100}$

0.2 Inequalities and Absolute Values

1 Solve Inequality and Graph

MULTIPLE CHOICE. Choose the one alternative that best completes the statement or answers the question.

State the solution set of the inequality in interval notation and sketch its graph.

1) $8x + 4 > 7x + 6$

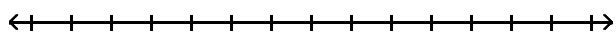

A) $(2, \infty)$

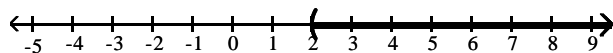

B) $(-\infty, 2]$

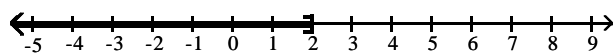

C) $(10, \infty)$

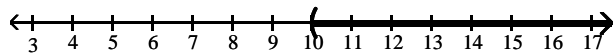

D) $[2, \infty)$

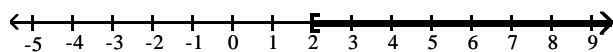

2) $-3x - 3 \geq -4x + 3$

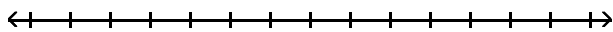

A) $[6, \infty)$

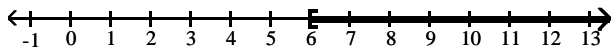

B) $(-\infty, 6)$

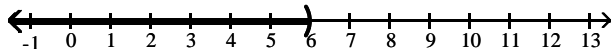

C) $(-\infty, 6]$

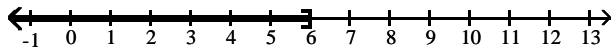

D) $(0, \infty)$

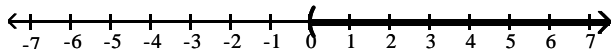

3) $15x + 15 > 3(4x + 7)$

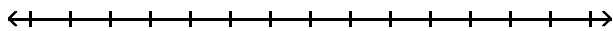

A) $(2, \infty)$

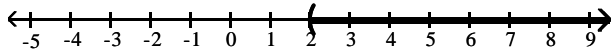

B) $[2, \infty)$

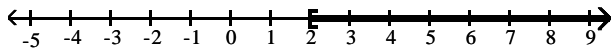

C) $(-\infty, 2)$

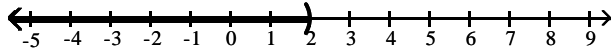

D) $(12, \infty)$

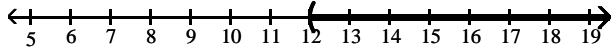

4) $-20x + 16 \leq -4(4x - 3)$

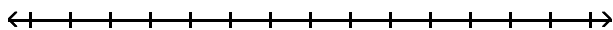

A) $[1, \infty)$

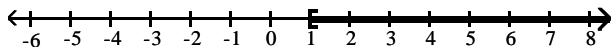

B) $(-\infty, 1]$

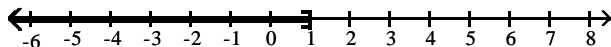

C) $(1, \infty)$

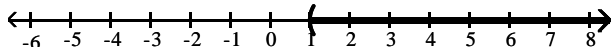

D) $(-\infty, 1)$

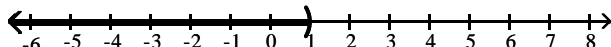

5) $13 \leq 4x + 1 \leq 21$

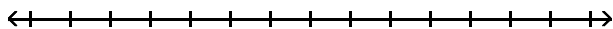

A) $[3, 5]$

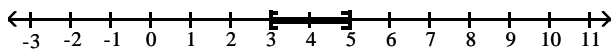

B) $(3, 5)$

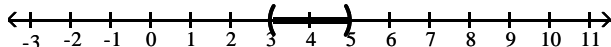

C) $[-5, -3]$

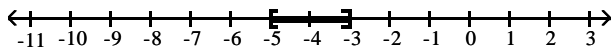

D) $(-5, -3)$

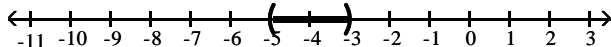

6) $-11 \leq -2x + 3 < -3$

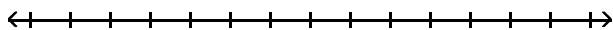

A) $(3, 7]$

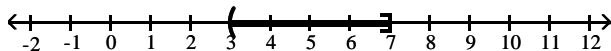

B) $[3, 7)$

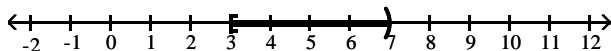

C) $[-7, -3)$

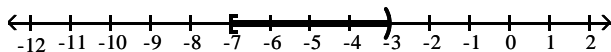

D) $(-7, -3]$

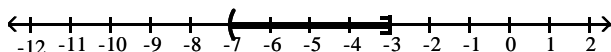

7) $x^2 + 6x + 5 > 0$

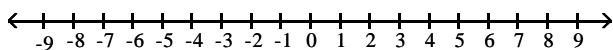

A) $(-\infty, -5) \cup (-1, \infty)$

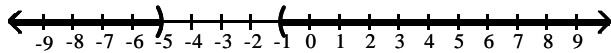

B) $(-5, -1)$

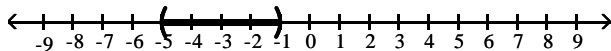

C) $(-\infty, -5)$

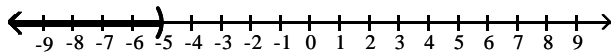

D) $(-1, \infty)$

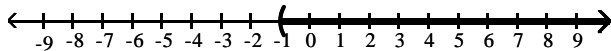

8) $x^2 - 4x - 5 < 0$

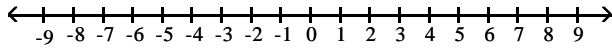

A) $(-1, 5)$

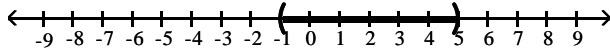

B) $(-\infty, -1)$

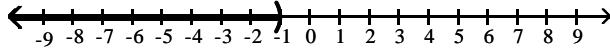

C) $(5, \infty)$

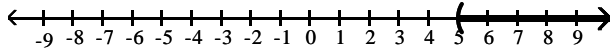

D) $(-\infty, -1) \cup (5, \infty)$

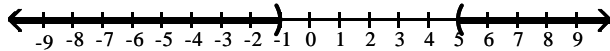

9) $2x^2 + 5x - 25 \leq 0$

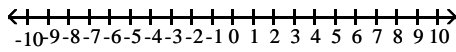

A) $\left[-5, \frac{5}{2}\right]$

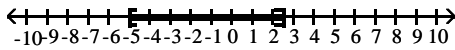

B) $(-\infty, -5] \cup \left[\frac{5}{2}, \infty\right)$

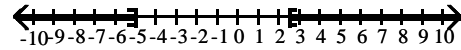

C) $\left[-\infty, \frac{5}{2}\right]$

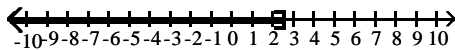

D) $[-5, \infty)$

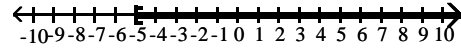

10) $(x + 7)(x - 1)(x - 3) > 0$

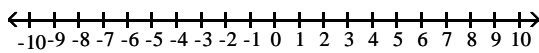

A) $(-7, 1) \cup (3, \infty)$

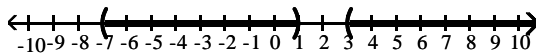

B) $(-\infty, -7) \cup (1, 3)$

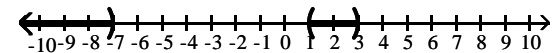

C) $(3, \infty)$

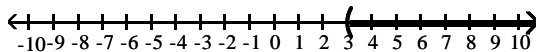

D) $(-\infty, 1)$

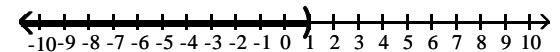

11) $(3x - 4)(x + 3) \leq 0$

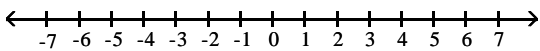

A) $\left[-3, \frac{4}{3}\right]$

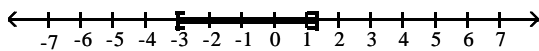

B) $(-\infty, -3] \cup \left[\frac{4}{3}, \infty\right)$

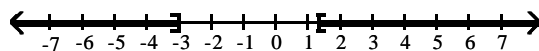

C) $\left(-\infty, \frac{4}{3}\right]$

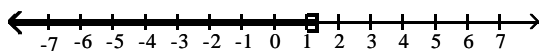

D) $[-3, \infty)$

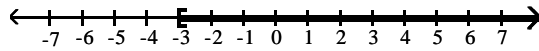

12) $4x^3 + 20x^2 - 9x - 45 > 0$

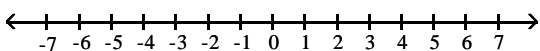

A) $\left(-5, -\frac{3}{2}\right) \cup \left(\frac{3}{2}, \infty\right)$

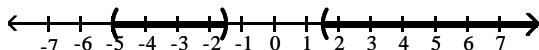

B) $\left(\frac{3}{2}, \infty\right)$

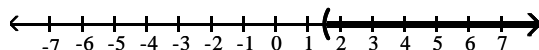

C) $(-\infty, -5) \cup \left(-\frac{3}{2}, \frac{3}{2}\right)$

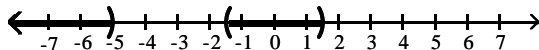

D) $(-\infty, -5] \cup \left[-\frac{3}{2}, \frac{3}{2}\right]$

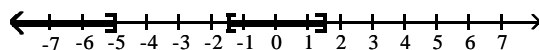

13) $\frac{x-1}{x+6} < 0$

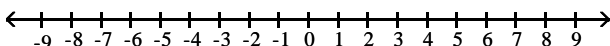

A) $(-6, 1)$

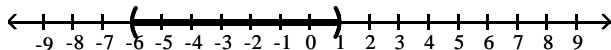

B) $(-\infty, -6)$ or $(1, \infty)$

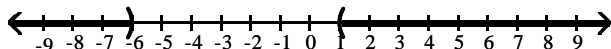

C) $(1, \infty)$

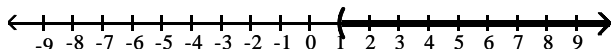

D) $(-\infty, -6)$

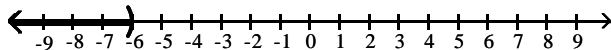

$$14) \frac{x-7}{x+6} > 0$$

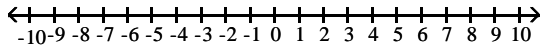

A) $(-\infty, -6)$ or $(7, \infty)$

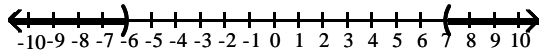

B) $(-6, 7)$

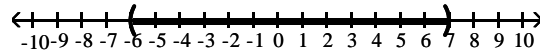

C) $(7, \infty)$

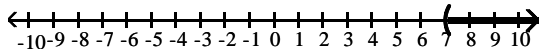

D) $(-\infty, -6)$

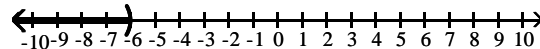

$$15) \frac{x+9}{x+2} < 2$$

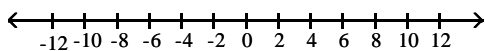

A) $(-\infty, -2)$ or $(5, \infty)$

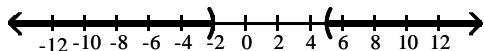

B) $(-2, 5)$

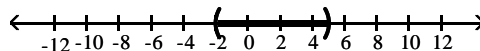

C) $(-\infty, 5)$ or $(2, \infty)$

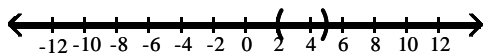

D) \emptyset

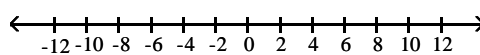

2 Determine Truth of Inequality

TRUE/FALSE. Write 'T' if the statement is true and 'F' if the statement is false.

Determine whether the statement is true or false.

1) $-12 < -6$

2) $-11 > -6$

3) $-5 < -\frac{56}{11}$

4) $-3 > -\frac{34}{11}$

5) $-5 < -\sqrt{28}$

6) $-5 > -\sqrt{26}$

7) $\frac{3}{4} > \frac{9}{13}$

8) $\frac{2}{3} < \frac{5}{8}$

MULTIPLE CHOICE. Choose the one alternative that best completes the statement or answers the question.

9) $a^2 \leq ab$, if $a \geq b$.

A) False

B) True

3 Solve Compound Inequality (and)

MULTIPLE CHOICE. Choose the one alternative that best completes the statement or answers the question.

Solve the compound inequality. Express the solution using interval notation. Graph the solution set.

1) $x \leq 1$ and $x \geq -3$

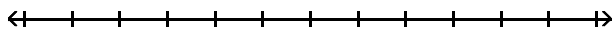

A) $[-3, 1]$

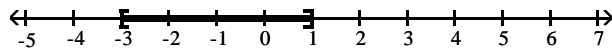

B) $(-\infty, -3] \cup [1, \infty)$

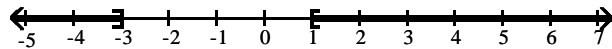

C) $(-3, 1)$

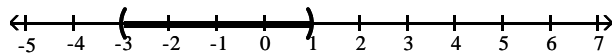

D) \emptyset

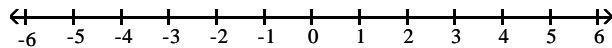

2) $x \leq 5$ and $x \leq 4$

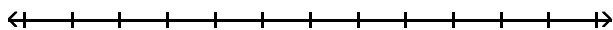

A) $(-\infty, 4]$

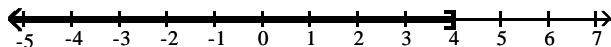

B) $(-\infty, 4] \cup [5, \infty)$

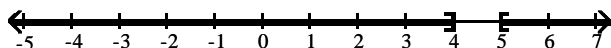

C) $[4, 5]$

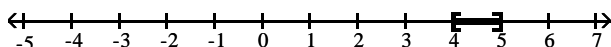

D) $[4, \infty)$

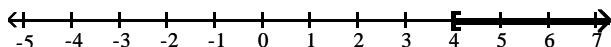

3) $6x < 30$ and $x + 6 > 8$

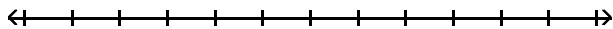

A) $(2, 5)$

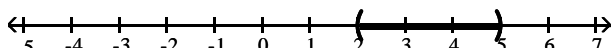

B) $(-\infty, 2) \cup (5, \infty)$

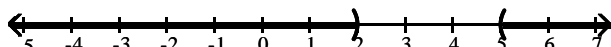

C) $[2, 5]$

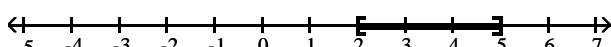

D) \emptyset

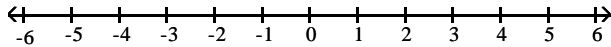

4) $-8x > -24$ and $x + 8 > 5$

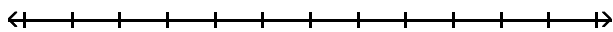

A) $(-3, 3)$

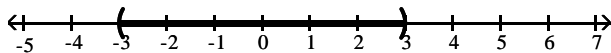

B) $(-\infty, -3) \cup (3, \infty)$

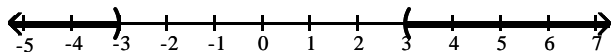

C) $(3, \infty)$

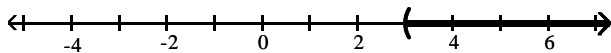

D) \emptyset

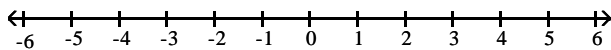

5) $x + 6 < 9$ and $-6x < -24$

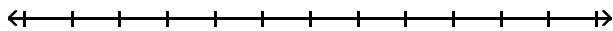

A) $(3, 4)$

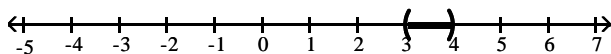

B) $(-\infty, 3) \cup (4, \infty)$

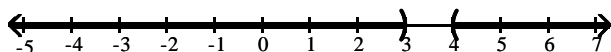

C) $(-\infty, 3)$

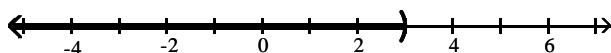

D) \emptyset

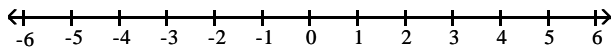

6) $-9x < -36$ and $x + 9 > 12$

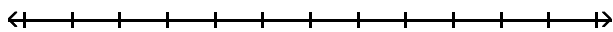

A) $(4, \infty)$

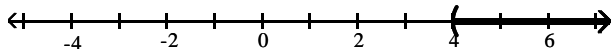

B) $(-\infty, 3) \cup (4, \infty)$

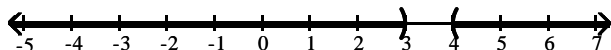

C) $(3, 4)$

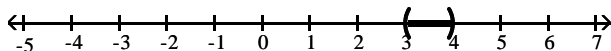

D) \emptyset

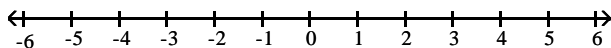

4 Solve Compound Inequality (or)

MULTIPLE CHOICE. Choose the one alternative that best completes the statement or answers the question.

Solve the compound inequality. Express the solution using interval notation. Graph the solution set.

1) $x \leq 3$ or $x \geq 7$

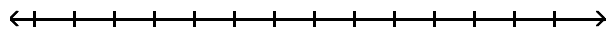

A) $(-\infty, 3] \cup [7, \infty)$

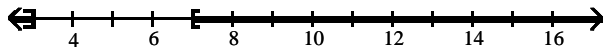

B) $(-3, 7)$

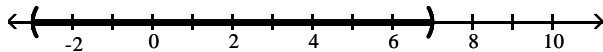

C) $[-7, -3]$

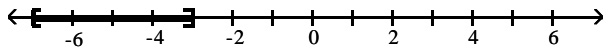

D) $(3, 7)$

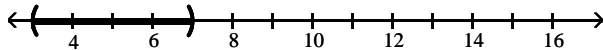

2) $x < 4$ or $x < 9$

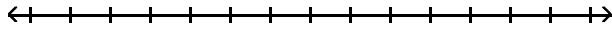

A) $(-\infty, 9)$

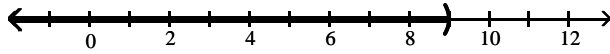

B) $(4, 9)$

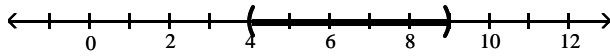

C) $(-\infty, 4) \cup (9, \infty)$

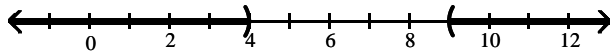

D) $(4, \infty)$

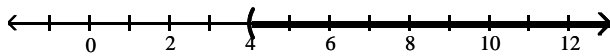

3) $x > 2$ or $x < 2$

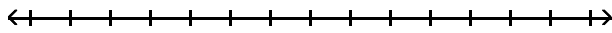

A) $(-\infty, 2) \cup (2, \infty)$

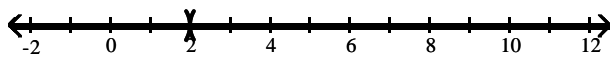

B) $(2, \infty)$

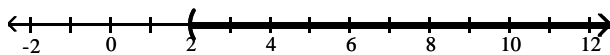

C) $(-\infty, 2)$

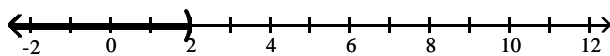

D) $(2, 2)$

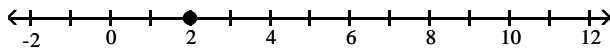

4) $12x - 8 < 4x$ or $-3x \leq -9$

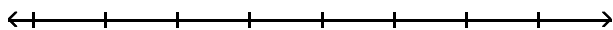

A) $(-\infty, 1) \cup [3, \infty)$

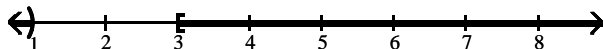

B) $(1, 3)$

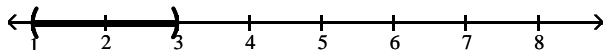

C) $[1, 3]$

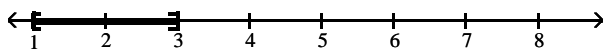

D) \emptyset

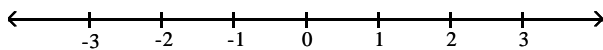

5) $-6x + 1 \geq 13$ or $3x + 3 \geq -9$

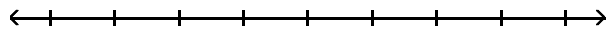

A) $[-2, \infty)$

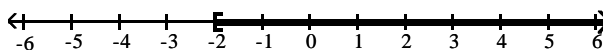

B) $[-4, -2]$

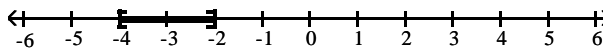

C) $[-4, \infty)$

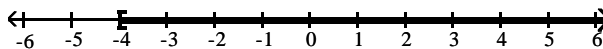

D) $(-\infty, \infty)$

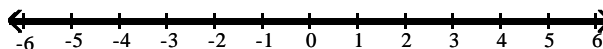

5 Solve Absolute Value Inequality

MULTIPLE CHOICE. Choose the one alternative that best completes the statement or answers the question.

Solve the inequality. Graph the solution set, and state the solution set in interval notation.

1) $|x - 1| < 4$

A) $(-3, 5)$

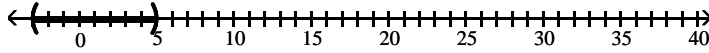

B) $(-5, 3)$

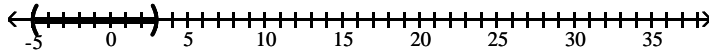

C) $(-\infty, 5)$

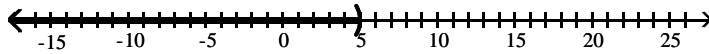

D) $(-\infty, -3)$

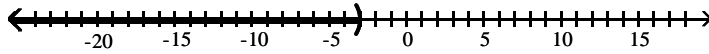

2) $|3k - 1| \leq 6$

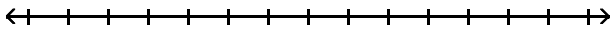

A) $\left[-\frac{5}{3}, \frac{7}{3}\right]$

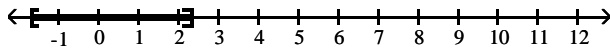

B) $\left(-\infty, -\frac{5}{3}\right) \cup \left[\frac{7}{3}, \infty\right)$

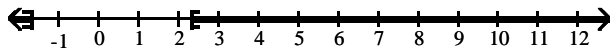

C) $\left(-\frac{5}{3}, \frac{7}{3}\right)$

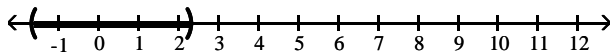

D) $\left(-\infty, \frac{7}{3}\right)$

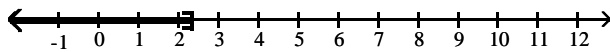

3) $|7k + 3| < -5$

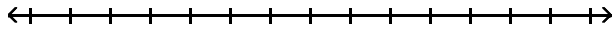

A) $\left(-\frac{8}{7}, \frac{2}{7}\right)$

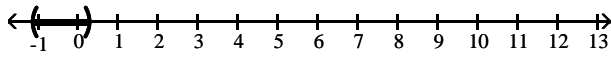

B) $\left(-\infty, -\frac{8}{7}\right) \cup \left(\frac{2}{7}, \infty\right)$

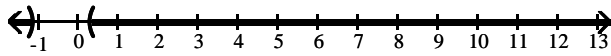

C) $\left(-\frac{2}{7}, \frac{8}{7}\right)$

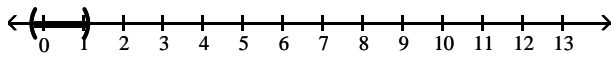

D) \emptyset

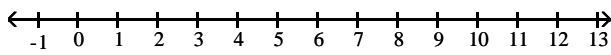

4) $|x - 2| \leq 0$

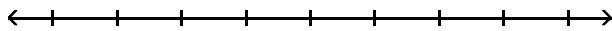

A) 2

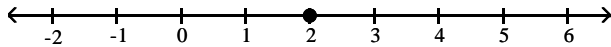

B) -2

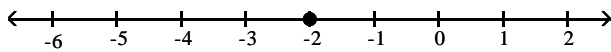

C) $(-\infty, 2)$

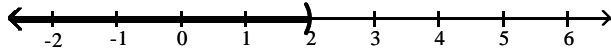

D) \emptyset

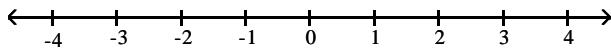

$$5) \left| \frac{11y + 33}{3} \right| < 11$$

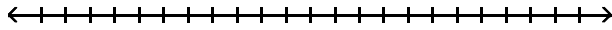

A) $(-6, 0)$

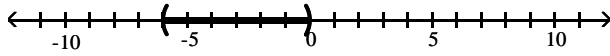

B) $(-6, 6)$

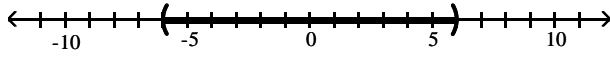

C) $(0, 6)$

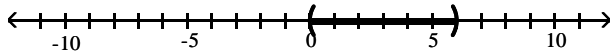

D) $(-\infty, -6) \cup (0, \infty)$

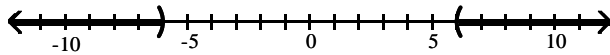

$$6) |x - 5| > 9$$

A) $(-\infty, -4) \cup (14, \infty)$

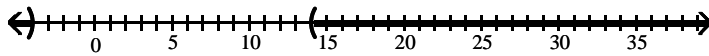

B) $(-14, 4)$

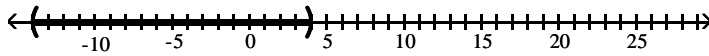

C) $(-4, 14)$

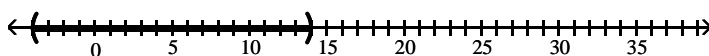

D) $(14, \infty)$

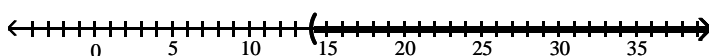

7) $|8k + 9| \geq 2$

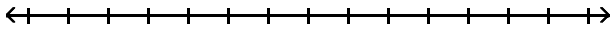

A) $\left(-\infty, -\frac{11}{8}\right] \cup \left[-\frac{7}{8}, \infty\right)$

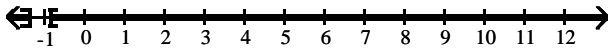

B) $\left[-\frac{11}{8}, -\frac{7}{8}\right]$

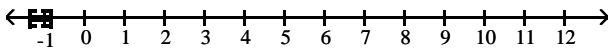

C) $\left(-\frac{11}{8}, -\frac{7}{8}\right)$

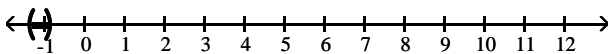

D) $\left[-\frac{7}{8}, \infty\right)$

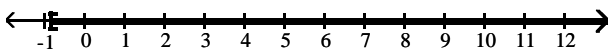

8) $|x - 5| \geq 0$

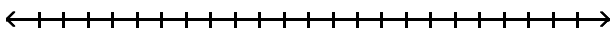

A) -6

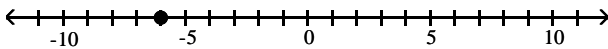

B) $(-\infty, 6) \cup (6, \infty)$

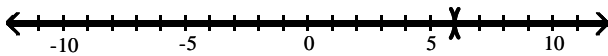

C) $(-\infty, -6) \cup (-6, \infty)$

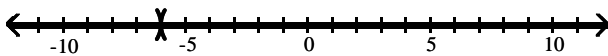

D) $(-\infty, \infty)$

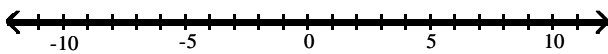

9) $\left| \frac{4y + 12}{3} \right| > 4$

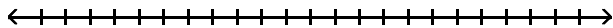

A) $(-\infty, -6) \cup (0, \infty)$

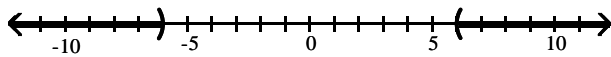

B) $(-6, 6)$

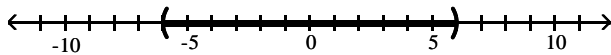

C) $(0, \infty)$

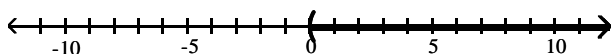

D) $(-6, 0)$

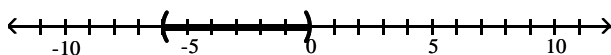

10) $|3x - 7| > 0$

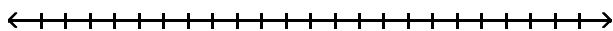

A) $\left(-\infty, \frac{7}{3}\right) \cup \left(\frac{7}{3}, \infty\right)$

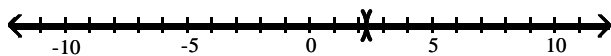

B) $\left(-\frac{7}{3}, \frac{7}{3}\right)$

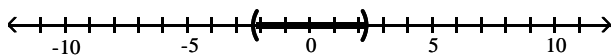

C) $\left(\frac{7}{3}, \infty\right)$

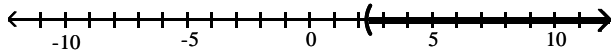

D) $\left(-\infty, -\frac{7}{3}\right) \cup \left(\frac{7}{3}, \infty\right)$

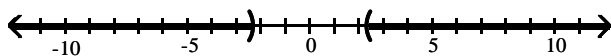

6 Find Delta To Make True Statement

MULTIPLE CHOICE. Choose the one alternative that best completes the statement or answers the question.

Find δ (depending on ϵ) so that the stated implication is true.

1) $|x - 2| < \delta \Rightarrow |3x - 6| < \epsilon$

A) $\frac{\epsilon}{3}$

B) $\frac{\epsilon}{2}$

C) 3ϵ

D) 2ϵ

2) $|x + 6| < \delta \Rightarrow |7x + 42| < \epsilon$

A) $\frac{\epsilon}{7}$

B) $\frac{\epsilon}{8}$

C) $\frac{\epsilon}{6}$

D) $\frac{\epsilon}{9}$

0.3 The Rectangular Coordinate System

1 Use Distance and Midpoint Formulas

MULTIPLE CHOICE. Choose the one alternative that best completes the statement or answers the question.

Answer the question.

1) What is the distance between the points (6, 6) and (-6, -5)?

A) $\sqrt{265}$

B) $\sqrt{23}$

C) 132

D) 1

2) What is the distance between the points (3, -4) and (7, -2)?

A) $2\sqrt{5}$

B) $12\sqrt{3}$

C) 12

D) 2

3) What is the distance between the points (-6, -4) and (3, 2)?

A) $3\sqrt{13}$

B) $45\sqrt{5}$

C) 45

D) 3

4) What is the distance between the points (-3, 4) and (1, -2)?

A) $2\sqrt{13}$

B) $20\sqrt{5}$

C) 20

D) 10

5) Three vertices of a rectangle are (-7, -6), (-3, -6), and (-3, 8). What are the coordinates of the fourth vertex?

A) (-7, 8)

B) (8, -7)

C) (-6, -7)

D) (8, -3)

6) (7, 1) is the vertex of the right angle of an isosceles right triangle. (-8, 1) is a second vertex of the triangle. What are the coordinates of the third vertex?

A) (7, -14) or (7, 16)

B) (7, -14)

C) (-8, -14) or (-8, 16)

D) (-8, -14)

7) The coordinates of P are (-2, 1), and the coordinates of Q are (8, 9). What are the coordinates of the point half-way between P and Q?

A) (3, 5)

B) (-5, -4)

C) (3, -4)

D) (-5, 5)

8) The coordinates of P are (1, 7), and the coordinates of Q are (2, -7). What are the coordinates of R such that Q is halfway between P and R?

A) (3, -21)

B) (0, 21)

C) (1.5, 0)

D) (3, 0)

- 9) The coordinates of the endpoints of one side of a square are $(-2, 1)$ and $(8, 1)$. What are the coordinates of the other two vertices?
- A) $(-2, 11)$ and $(8, 11)$; or $(-2, -9)$ and $(8, -9)$ B) $(-2, 11)$ and $(8, 11)$
 C) $(-2, -9)$ and $(8, -9)$ D) $(-2, 9)$ and $(8, 9)$

2 Find Equation of Circle

MULTIPLE CHOICE. Choose the one alternative that best completes the statement or answers the question.

Find the equation of the circle satisfying the given conditions.

- 1) Center: $(0, 0)$, radius: 12

A) $x^2 + y^2 = 144$ B) $x^2 + y^2 = 12$ C) $x^2 + y^2 = 24$ D) $x^2 - y^2 = 12$

- 2) Center: $(0, 0)$, radius: $\sqrt{11}$

A) $x^2 + y^2 = 11$ B) $x^2 + y^2 = \sqrt{11}$ C) $x^2 + y^2 = \frac{11}{4}$ D) $x^2 + y^2 = 121$

- 3) Center: $(10, 0)$, radius: 9

A) $(x - 10)^2 + y^2 = 81$ B) $(x + 10)^2 + y^2 = 81$ C) $x^2 + (y - 10)^2 = 9$ D) $x^2 + (y + 10)^2 = 9$

- 4) Center: $(0, -7)$, radius: 3

A) $x^2 + (y + 7)^2 = 9$ B) $x^2 + (y - 7)^2 = 3$ C) $(x + 7)^2 + y^2 = 9$ D) $(x - 7)^2 + y^2 = 9$

- 5) Center: $(0, 9)$, radius: $\sqrt{6}$

A) $x^2 + (y - 9)^2 = 6$ B) $x^2 + (y + 9)^2 = 6$ C) $(x - 9)^2 + y^2 = 36$ D) $(x + 9)^2 + y^2 = 36$

- 6) Center: $(-2, -5)$, radius: 4

A) $(x + 2)^2 + (y + 5)^2 = 16$ B) $(x - 2)^2 + (y - 5)^2 = 16$
 C) $(x + 5)^2 + (y + 2)^2 = 4$ D) $(x - 5)^2 + (y - 2)^2 = 4$

- 7) Center: $(1, 10)$, radius: $\sqrt{19}$

A) $(x - 1)^2 + (y - 10)^2 = 19$ B) $(x + 1)^2 + (y + 10)^2 = 19$
 C) $(x - 10)^2 + (y - 1)^2 = 361$ D) $(x + 10)^2 + (y + 1)^2 = 361$

- 8) Center at the origin and containing the point $(4, -9)$.

A) $x^2 + y^2 = 97$ B) $x^2 + y^2 = \sqrt{97}$ C) $x^2 + y^2 = -5$ D) $x^2 + y^2 = 3$

- 9) Center at $(7, 5)$ and containing the point $(5, 1)$.

A) $(x - 7)^2 + (y - 5)^2 = 20$ B) $(x - 7)^2 + (y - 5)^2 = 2\sqrt{5}$
 C) $(x + 7)^2 + (y + 5)^2 = 20$ D) $(x + 7)^2 + (y + 5)^2 = 2\sqrt{5}$

- 10) Center at $(-4, 3)$ and tangent to the y -axis.

A) $(x + 4)^2 + (y - 3)^2 = 16$ B) $(x + 4)^2 + (y - 3)^2 = 9$
 C) $(x - 4)^2 + (y + 3)^2 = 16$ D) $(x + 4)^2 + (y - 3)^2 = 4$

11) Center at (5, -2) and tangent to the x-axis.

A) $(x - 5)^2 + (y + 2)^2 = 4$

C) $(x - 5)^2 + (y + 2)^2 = 5$

B) $(x - 5)^2 + (y + 2)^2 = 25$

D) $(x - 5)^2 + (y + 2)^2 = 2$

12) With endpoints of a diameter at (-2, -6) and (-8, 2).

A) $(x + 5)^2 + (y + 2)^2 = 25$

C) $(x - 5)^2 + (y - 2)^2 = 25$

B) $(x + 5)^2 + (y + 2)^2 = 5$

D) $(x - 5)^2 + (y - 2)^2 = 100$

3 Find Center and Radius of Circle

MULTIPLE CHOICE. Choose the one alternative that best completes the statement or answers the question.

Find the center and radius of the circle.

1) $x^2 + y^2 - 18x - 10y + 106 = 25$

A) Center: (9, 5); Radius: 5

C) Center: (-9, -5); Radius: 25

B) Center: (5, 9); Radius: 5

D) Center: (-5, -9); Radius: 25

2) $x^2 + y^2 - 6x + 18y + 74 = 0$

A) Center: (3, -9); Radius: 4

C) Center: (-3, 9); Radius: 16

B) Center: (-9, 3); Radius: 4

D) Center: (9, -3); Radius: 16

3) $x^2 + y^2 + 4x - 10y + 19 = 0$

A) Center: (-2, 5); Radius: $\sqrt{10}$

C) Center: (2, -5); Radius: $\sqrt{10}$

B) Center: (5, -2); Radius: $\sqrt{10}$

D) Center: (-5, 2); Radius: $\sqrt{10}$

4) $x^2 - 4x + y^2 + 6y - 5 = 0$

A) Center: (2, -3); Radius: $3\sqrt{2}$

C) Center: (-2, 3); Radius: 18

B) Center: (2, -3); Radius: 18

D) Center: (-2, 3); Radius: $3\sqrt{2}$

5) $2x^2 + 2y^2 - 8x + 16y + 22 = 0$

A) Center: (2, -4); Radius: 3

C) Center: (-2, 4); Radius: 3

B) Center: (2, -4); Radius: 9

D) Center: (-2, 4); Radius: 9

4 Find Slope of Line

MULTIPLE CHOICE. Choose the one alternative that best completes the statement or answers the question.

Find the slope of the line that goes through the given points.

1) (-5, 8), (7, 7)

A) $-\frac{1}{12}$

B) -12

C) $\frac{15}{2}$

D) $\frac{1}{12}$

2) (-7, -5), (-7, 7)

A) Undefined

B) 0

C) $-\frac{1}{7}$

D) $\frac{6}{7}$

- 3) (9, 3), (1, 3)
 A) 0 B) Undefined C) $\frac{3}{5}$ D) $-\frac{3}{4}$
- 4) (14, 2), (-13, -4)
 A) $\frac{2}{9}$ B) $\frac{9}{2}$ C) -2 D) $-\frac{2}{9}$
- 5) (-3, 9), (-6, 1)
 A) $\frac{8}{3}$ B) $\frac{12}{7}$ C) $\frac{3}{8}$ D) $\frac{7}{12}$
- 6) (-4, 3), (-1, 3)
 A) 0 B) 2 C) 1 D) 11
- 7) (4, -3) and $(\frac{2}{5}, -4)$
 A) $\frac{5}{18}$ B) $\frac{35}{18}$ C) $\frac{18}{5}$ D) $-\frac{18}{5}$
- 8) $(\frac{2}{5}, -5)$ and $(\frac{2}{5}, 0)$
 A) Undefined B) $\frac{25}{18}$ C) $-\frac{18}{25}$ D) $-\frac{25}{18}$

5 Find Equation of Line

MULTIPLE CHOICE. Choose the one alternative that best completes the statement or answers the question.

Find an equation for the line. Then write your answer in the form $Ax + By + C = 0$.

- 1) Through (-2, 4) with slope 1
 A) $y = x + 6; x - y + 6 = 0$ B) $y = -x + 6; x + y - 6 = 0$
 C) $y = x - 6; x - y - 6 = 0$ D) $y = x + 2; x - y + 2 = 0$
- 2) Through (4, 2) with slope $-\frac{5}{6}$
 A) $y = -\frac{5}{6}x + \frac{16}{3}; 5x + 6y - 32 = 0$ B) $y = -\frac{5}{6}x - \frac{16}{3}; 5x + 6y + 32 = 0$
 C) $y = \frac{5}{6}x + \frac{16}{3}; 5x - 6y + 32 = 0$ D) $y = \frac{5}{6}x - \frac{16}{3}; 5x - 6y - 32 = 0$
- 3) Through (4, 7) with slope 0
 A) $y = 7; y - 7 = 0$ B) $x = 4; x - 4 = 0$ C) $y = 4; y - 4 = 0$ D) $x = 7; x - 7 = 0$
- 4) Through (-7, -8) with undefined slope
 A) $x = -7; x + 7 = 0$ B) $y = -8; y + 8 = 0$ C) $y = -7; y + 7 = 0$ D) $x = -8; x + 8 = 0$

5) With y-intercept 2 and slope 3

A) $y = 3x + 2$; $3x - y + 2 = 0$

C) $y = 2x + 3$; $2x - y + 3 = 0$

B) $y = 3x - 2$; $3x - y - 2 = 0$

D) $y = 2x + 3$; $2x - y - 3 = 0$

6) Through (5, -4) and (-2, -8)

A) $y = \frac{4}{7}x - \frac{48}{7}$; $4x - 7y - 48 = 0$

C) $y = -\frac{3}{2}x - 5$; $9x + 6y + 30 = 0$

B) $y = -\frac{4}{7}x - \frac{48}{7}$; $4x + 7y + 48 = 0$

D) $y = \frac{3}{2}x - 5$; $9x - 6y - 30 = 0$

7) Through (-3, 0) and (3, -5)

A) $y = -\frac{5}{6}x - \frac{5}{2}$; $5x + 6y + 15 = 0$

C) $y = \frac{3}{8}x - \frac{31}{8}$; $-3x + 8y + 31 = 0$

B) $y = \frac{5}{6}x - \frac{5}{2}$; $5x - 6y - 15 = 0$

D) $y = -\frac{3}{8}x - \frac{31}{8}$; $-3x - 8y - 31 = 0$

8) Through (-5, 11) and parallel to $5x + 4y = -13$

A) $y = -\frac{5}{4}x + \frac{19}{4}$; $5x + 4y - 19 = 0$

C) $y = -\frac{5}{4}x - \frac{19}{4}$; $5x + 4y + 19 = 0$

B) $y = \frac{5}{4}x - \frac{19}{4}$; $5x - 4y - 19 = 0$

D) $y = \frac{5}{4}x + \frac{19}{4}$; $5x - 4y + 19 = 0$

9) Through (-5, -7) and perpendicular to $6x + 5y = -65$

A) $y = \frac{5}{6}x - \frac{17}{6}$; $5x - 6y - 17 = 0$

C) $y = \frac{5}{6}x + \frac{17}{6}$; $5x - 6y + 17 = 0$

B) $y = -\frac{5}{6}x - \frac{17}{6}$; $5x + 6y + 17 = 0$

D) $y = -\frac{5}{6}x + \frac{17}{6}$; $5x + 6y - 17 = 0$

6 Find Slope and y-intercept

MULTIPLE CHOICE. Choose the one alternative that best completes the statement or answers the question.

Find the slope and y-intercept of the line.

1) $y + 2 = 0$

A) Slope: 0 ; y-intercept: -2

C) Slope: 1 ; y-intercept: -2

B) Slope: -2 ; y-intercept: 0

D) Slope: 0 ; no y-intercept

2) $x + y - 4 = 0$

A) Slope: -1 ; y-intercept: 4

C) Slope: 0 ; y-intercept: 4

B) Slope: 1 ; y-intercept: 4

D) Slope: -1 ; y-intercept: -4

3) $4x + y + 6 = 0$

A) Slope: -4 ; y-intercept: -6

C) Slope: 4 ; y-intercept: -6

B) Slope: $-\frac{1}{4}$; y-intercept: $-\frac{3}{2}$

D) Slope: $-\frac{2}{3}$; y-intercept: $-\frac{1}{6}$

4) $5x - 6y - 30 = 0$

A) Slope: $\frac{5}{6}$; y-intercept: -5

B) Slope: $-\frac{5}{6}$; y-intercept: 5

C) Slope: $\frac{6}{5}$; y-intercept: 6

D) Slope: 5 ; y-intercept: 30

5) $x + 8y - 1 = 0$

A) Slope: $-\frac{1}{8}$; y-intercept: $\frac{1}{8}$

B) Slope: 1 ; y-intercept: 1

C) Slope: $\frac{1}{8}$; y-intercept: $\frac{1}{8}$

D) Slope: -8 ; y-intercept: 8

6) $-x + 10y - 90 = 0$

A) Slope: $\frac{1}{10}$; y-intercept: 9

B) Slope: $-\frac{1}{10}$; y-intercept: 9

C) Slope: -1 ; y-intercept: 90

D) Slope: 10 ; y-intercept: -90

7 Find Value of Coefficient

MULTIPLE CHOICE. Choose the one alternative that best completes the statement or answers the question.

Solve the problem.

1) Find the value of k so that the graph of $22y - kx = 4$ and the line containing the points (5, -8) and (2, 4) are parallel.

A) $k = -88$

B) $k = -87$

C) $k = -90$

D) $k = -87.5$

2) Find the value of k so that the graph of $31y + kx = 4$ and the line containing the points (5, -8) and (2, 4) are perpendicular.

A) $k = -7.75$

B) $k = -124$

C) $k = 124$

D) $k = 7.75$

8 Find Point of Intersection of Two Lines

MULTIPLE CHOICE. Choose the one alternative that best completes the statement or answers the question.

Find the coordinates of the point of intersection of the two lines.

1) $x - y = 2$
 $x + 3y = 14$

A) (5, 3)

B) (5, -3)

C) (3, 5)

D) (3, -5)

2) $2x + y = 16$
 $x - 4y = -19$

A) (5, 6)

B) (5, -6)

C) (6, 5)

D) (6, -5)

3) $2y - 8 = 0$
 $x - 2y = -11$

A) (-3, 4)

B) (-3, -4)

C) (4, -3)

D) (4, 3)

$$4) \begin{cases} x + 7y = 7 \\ 2x - 3y = -3 \end{cases}$$

A) (0, 1)

B) (1, 0)

C) (1, 1)

D) (0, 0)

$$5) \begin{cases} 5x + y = 0 \\ -5x + y = -10 \end{cases}$$

A) (1, -5)

B) (-1, 5)

C) (1, 10)

D) (-1, -5)

9 Solve Apps: The Rectangular Coordinate System

MULTIPLE CHOICE. Choose the one alternative that best completes the statement or answers the question.

Solve the problem.

- 1) The ceiling of an attic makes an angle of 45° with the floor. A pipe of radius 2 inches is placed along the edge of the attic in such a way that one side of the pipe touches the ceiling and the other side touches the floor. What is the distance from the edge of the attic to where the pipe touches the floor?

A) 4.83 inches

B) 4.94 inches

C) 4.26 inches

D) 5.87 inches

10 Find Distance Between Point and Line

MULTIPLE CHOICE. Choose the one alternative that best completes the statement or answers the question.

Find the distance from the point to the line.

- 1) $(-8, 1)$; $3x + 4y = 9$

A) $\frac{29}{5}$

B) $-\frac{19}{5}$

C) $\frac{37}{5}$

D) $\frac{28}{5}$

- 2) $(4, -3)$; $12x - 5y = 4$

A) $\frac{59}{13}$

B) $\frac{59}{169}$

C) $\frac{29}{13}$

D) $\frac{67}{13}$

0.4 Graphs of Equations

1 Graph Equation

MULTIPLE CHOICE. Choose the one alternative that best completes the statement or answers the question.

Plot the graph of the equation. Check for symmetries and find all x - and y -intercepts.

1) $x^2 + y^2 - 4x - 4y - 1 = 0$

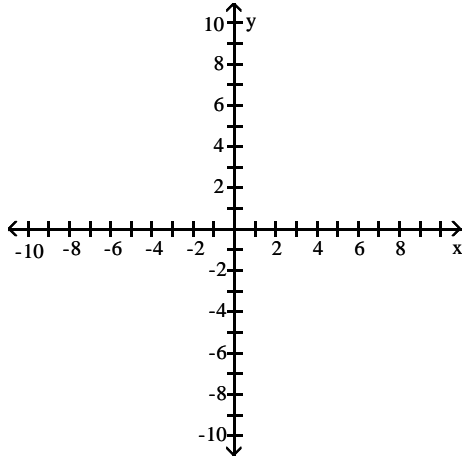

A)

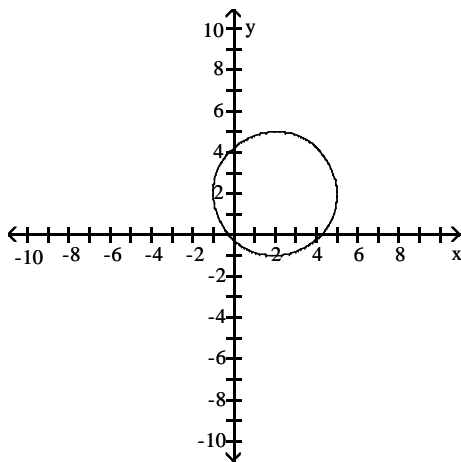

C)

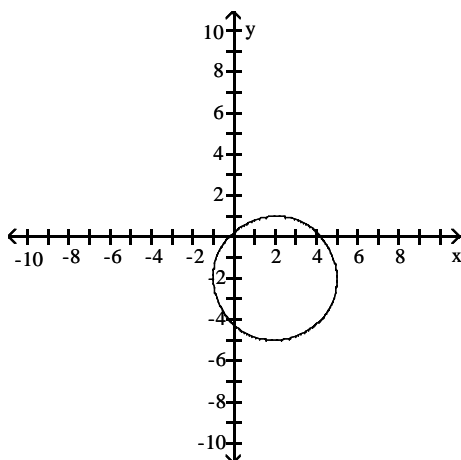

B)

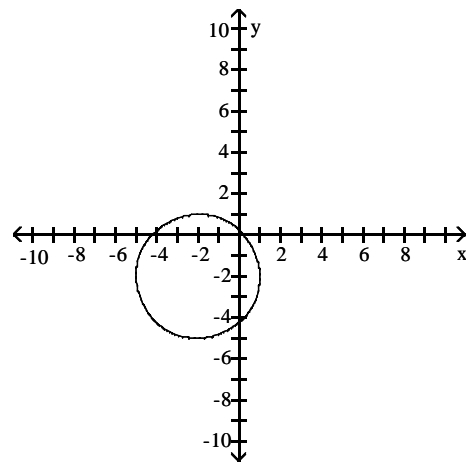

D)

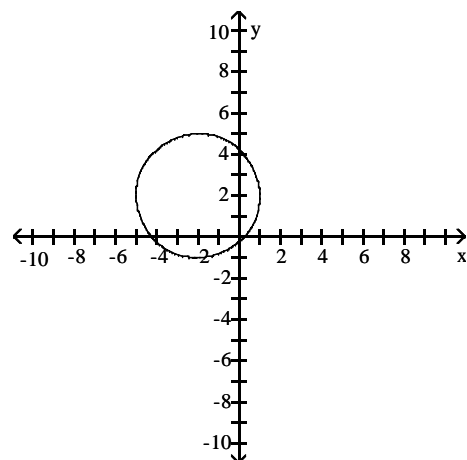

$$2) x^2 + y^2 + 4y - 2 = 0$$

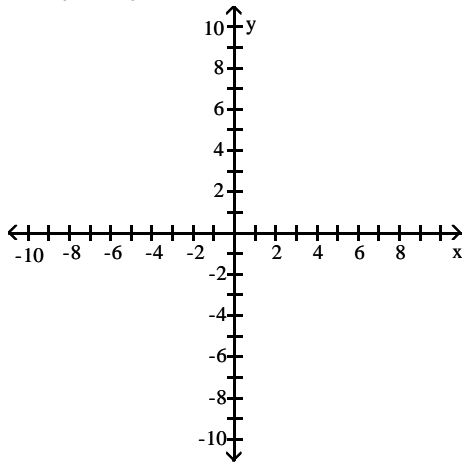

A)

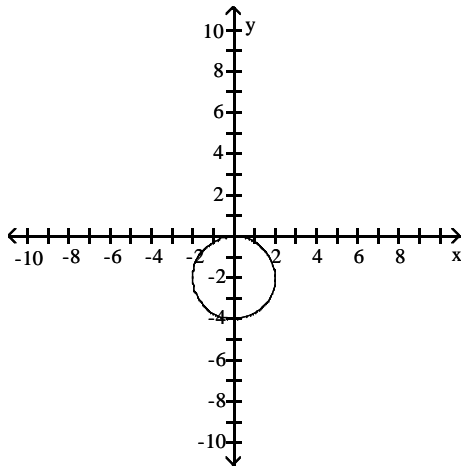

C)

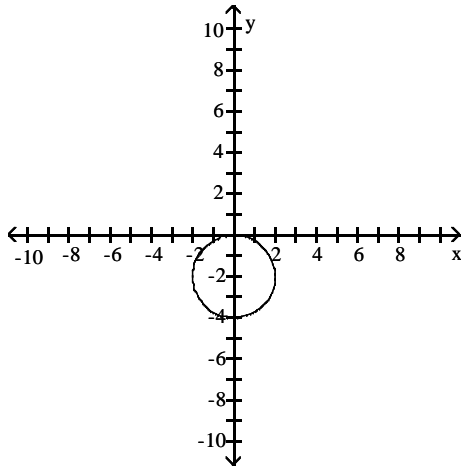

B)

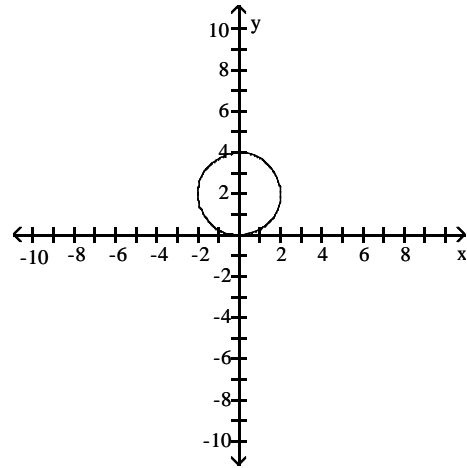

D)

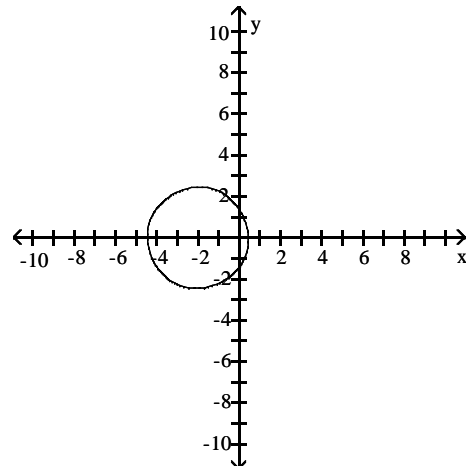

3) $x^2 + y^2 - 5x = 4$

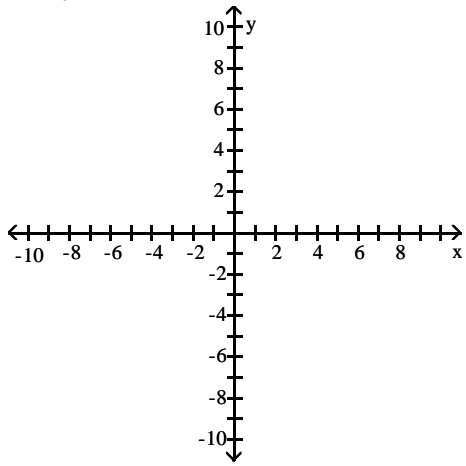

A)

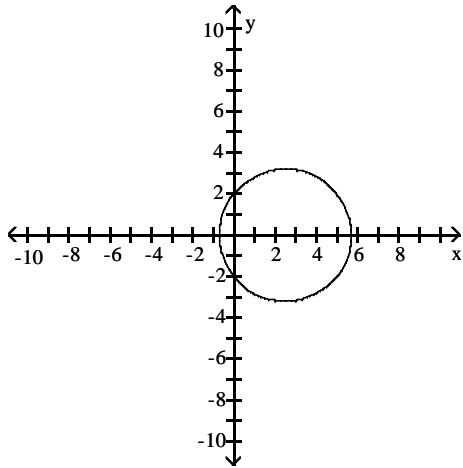

B)

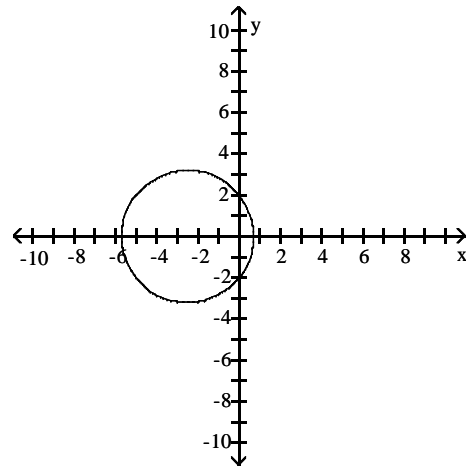

C)

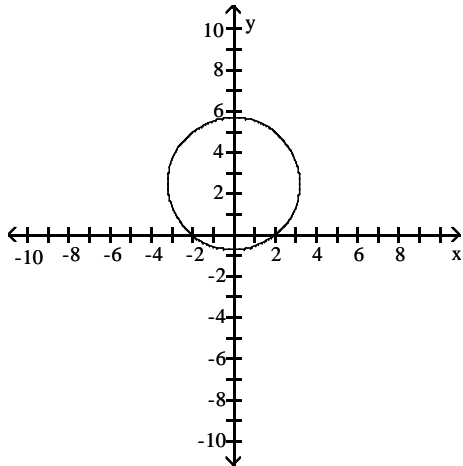

D)

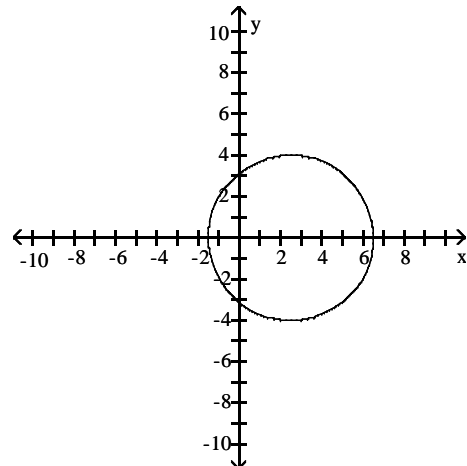

4) $y = x^2 - 2x - 6$

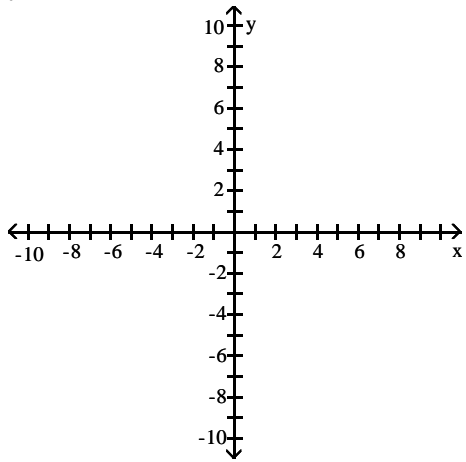

A)

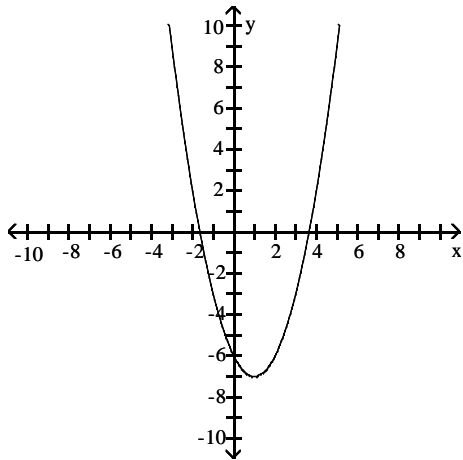

B)

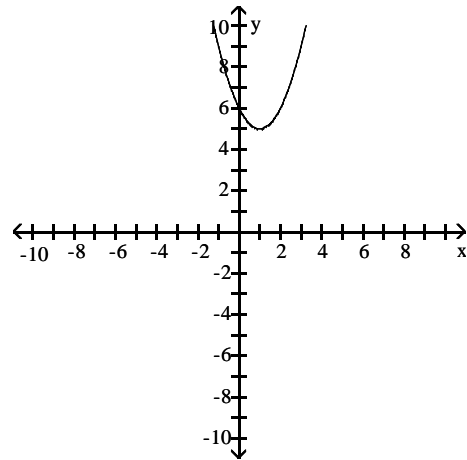

C)

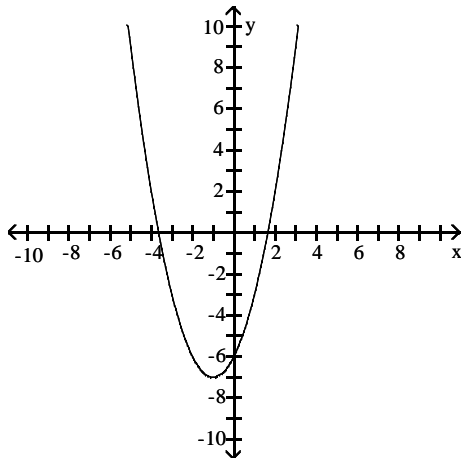

D)

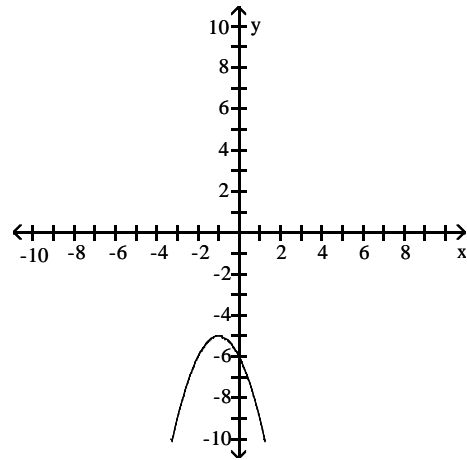

5) $y = -x^2 + 2x - 7$

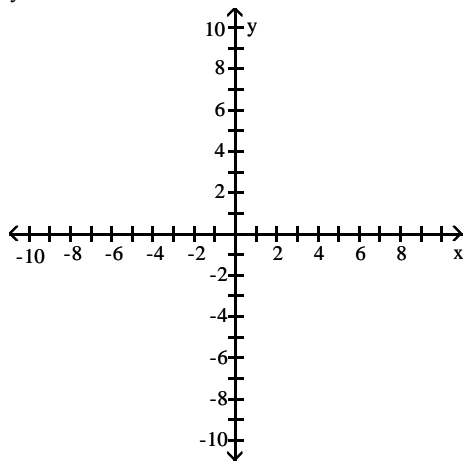

A)

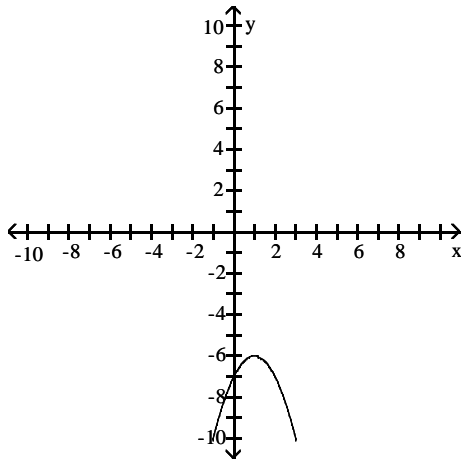

B)

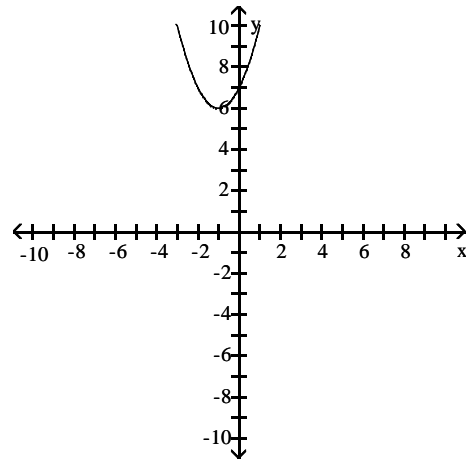

C)

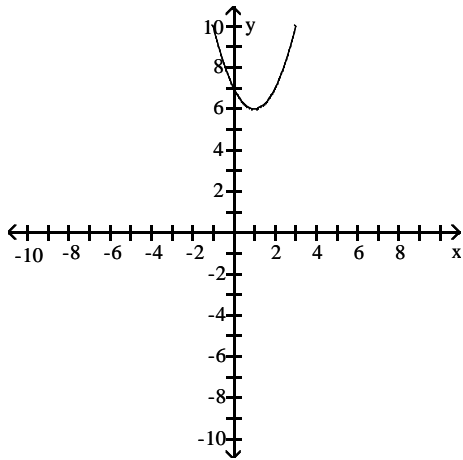

D)

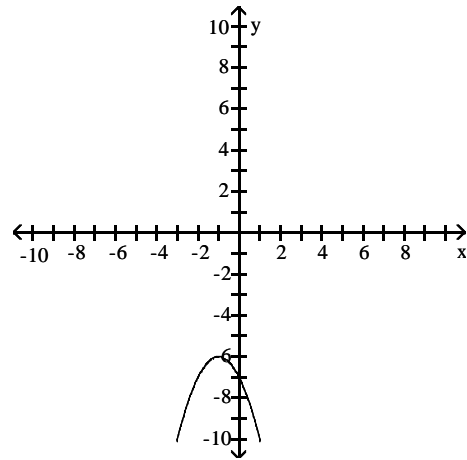

6) $y = 4x^2 - 2x + 2$

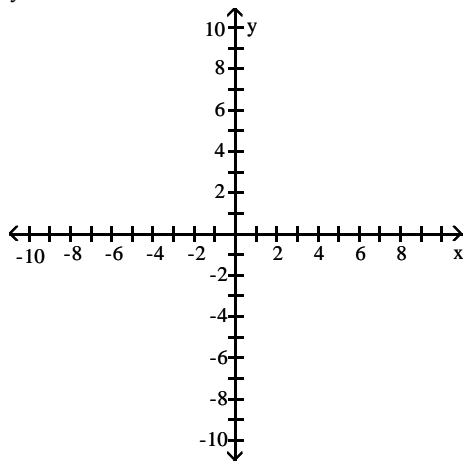

A)

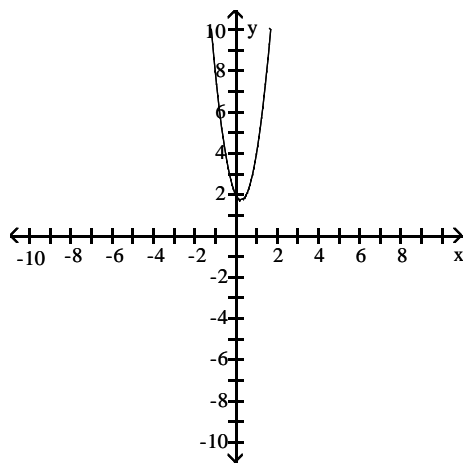

B)

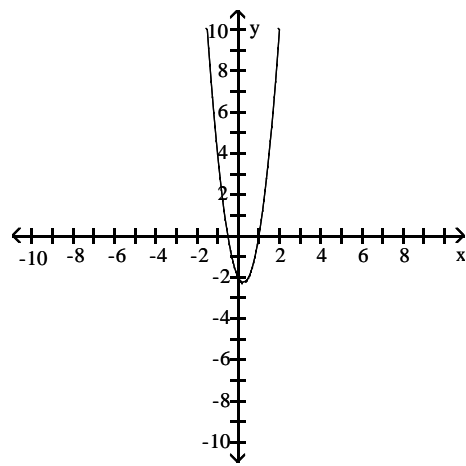

C)

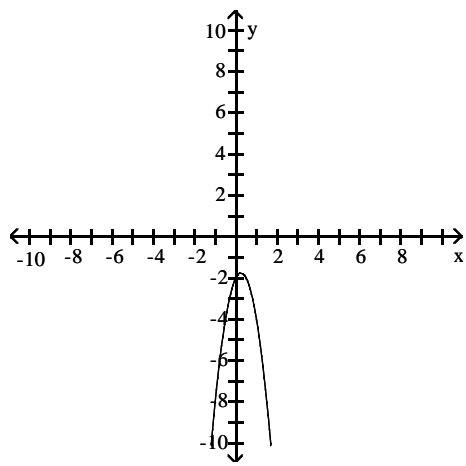

D)

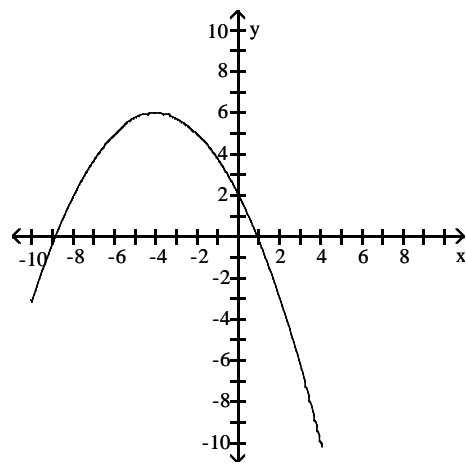

7) $9x^2 + 6y^2 = 18$

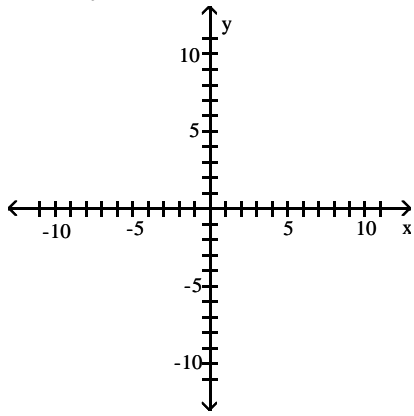

A)

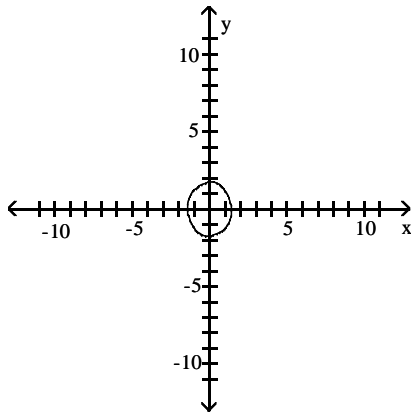

B)

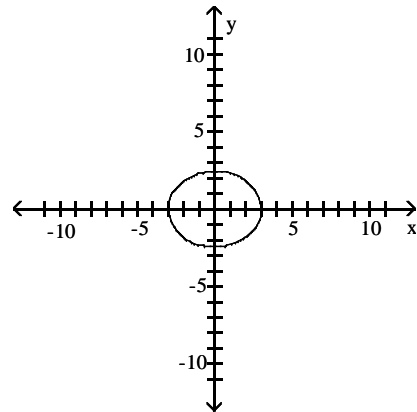

C)

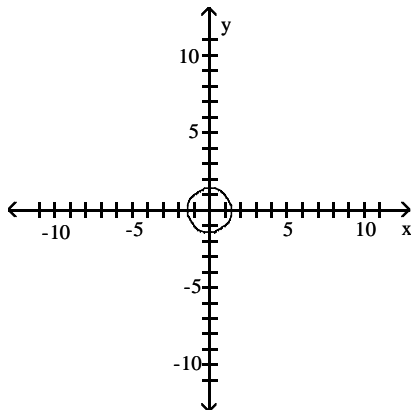

D)

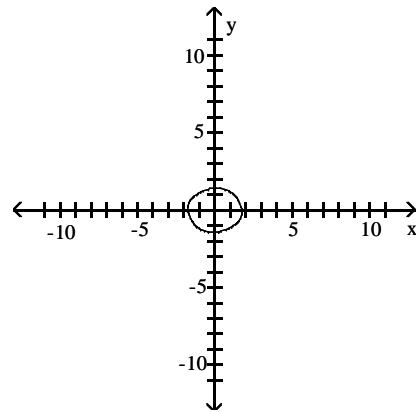

8) $x^2 + 9y^2 = 9$

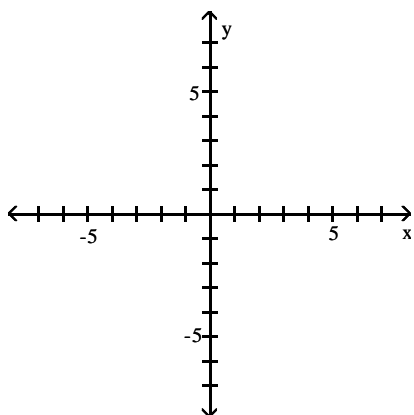

A)

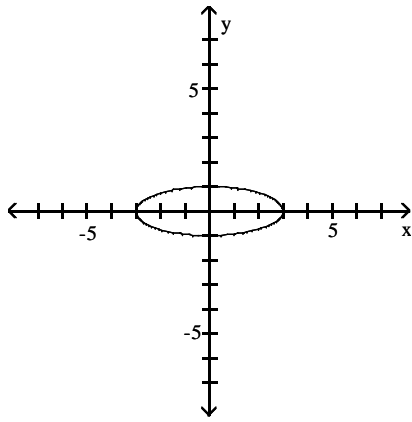

B)

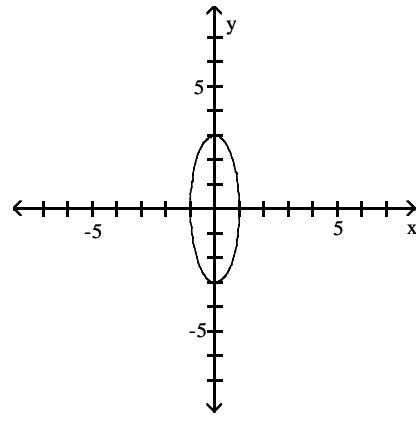

C)

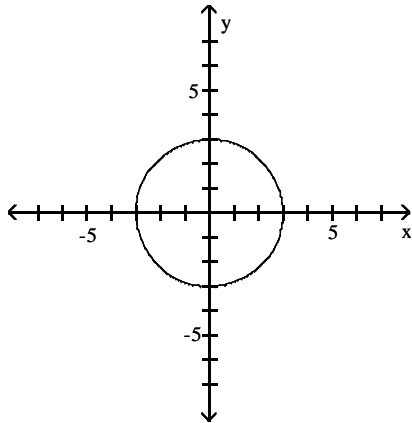

D)

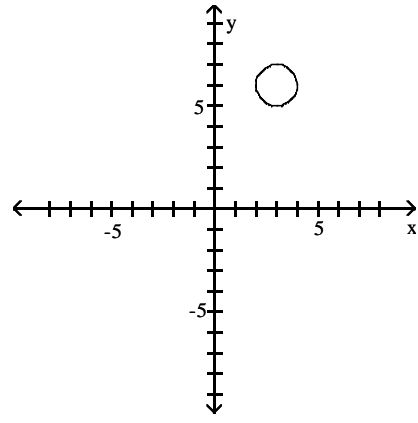

9) $9x^2 - 4y^2 = 36$

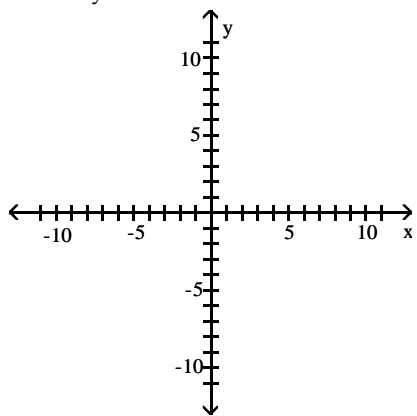

A)

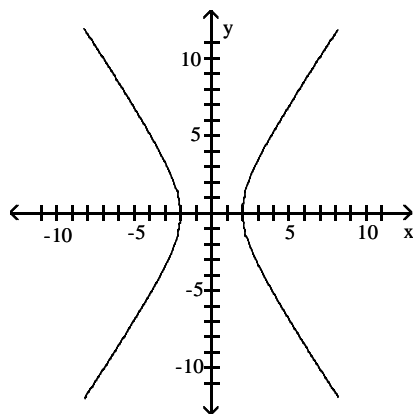

B)

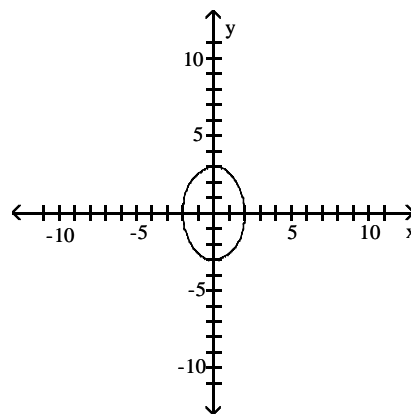

C)

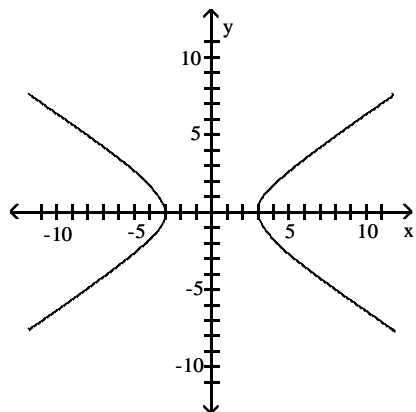

D)

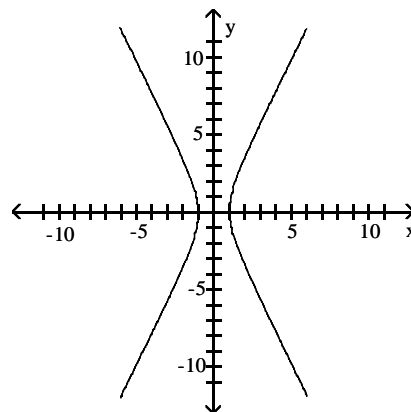

10) $x^2 - y^2 = 18$

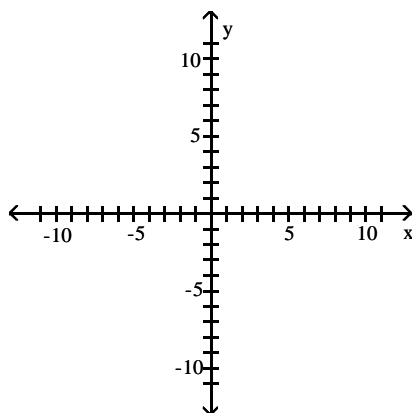

A)

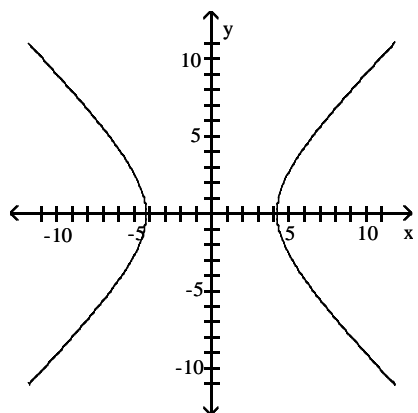

B)

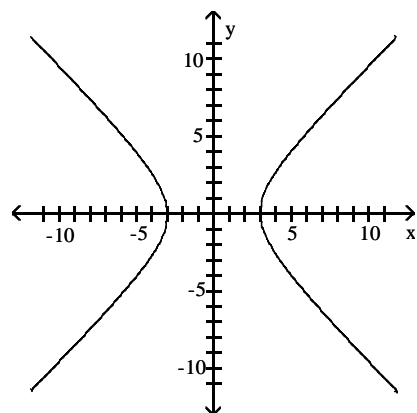

C)

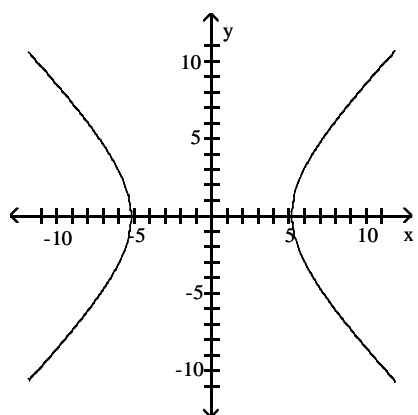

D)

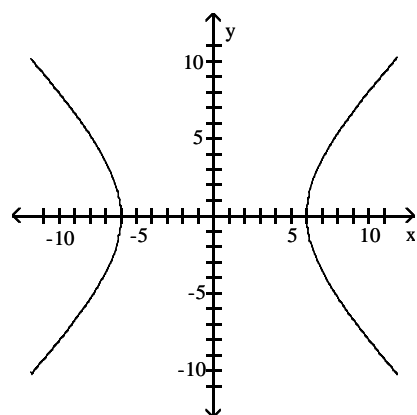

11) $y^2 - x^2 = \frac{1}{4}$

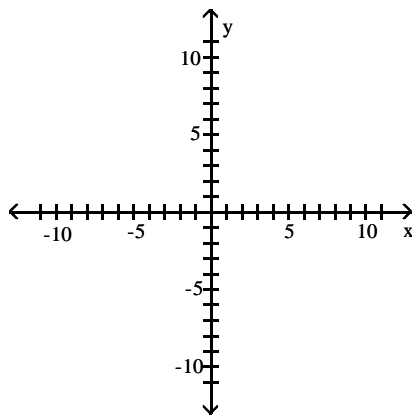

A)

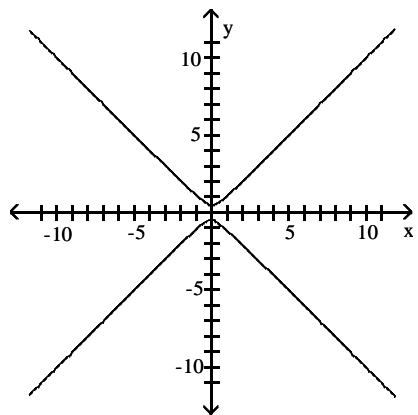

B)

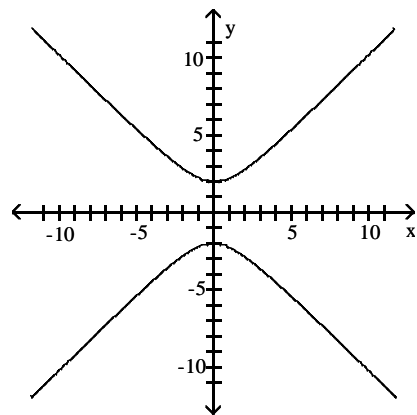

C)

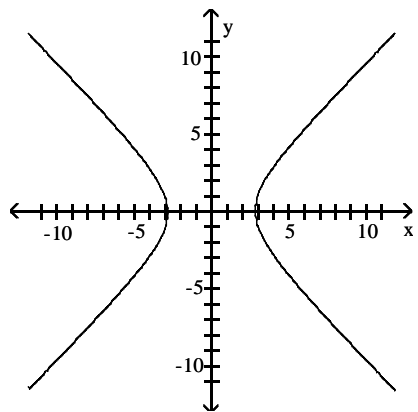

D)

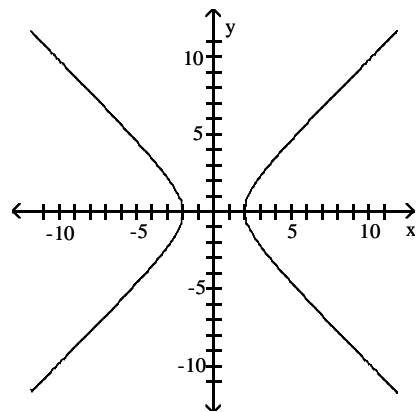

12) $y = x^4 - 9x^2$

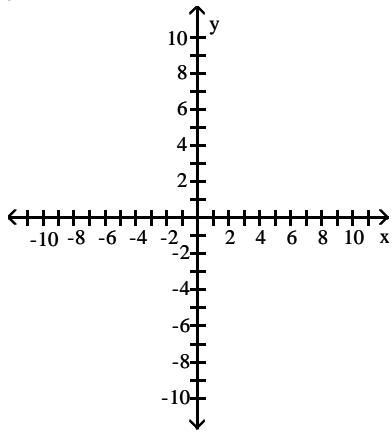

A)

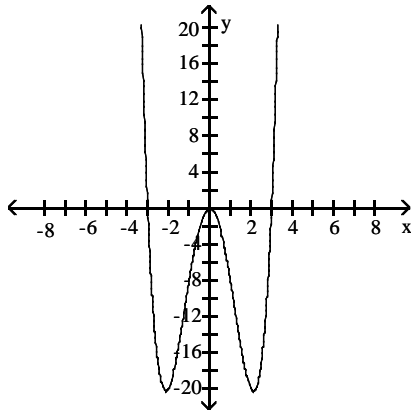

B)

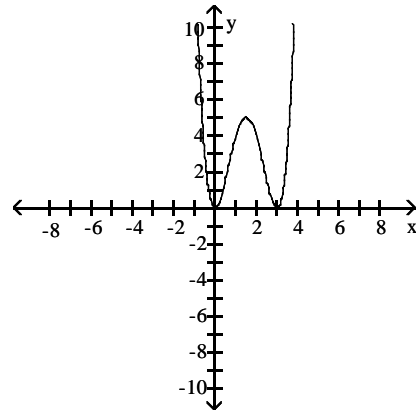

C)

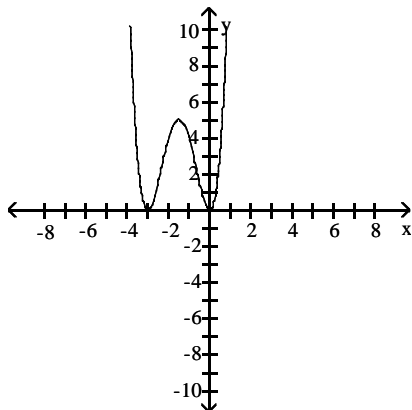

D)

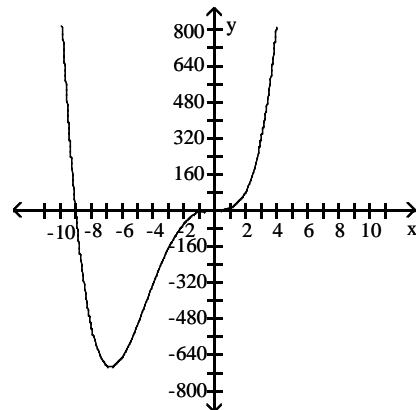

13) $y = 2x^2 - x^3$

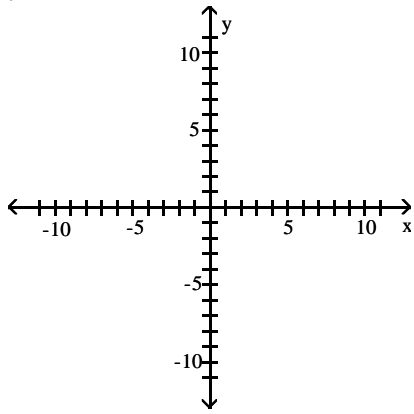

A)

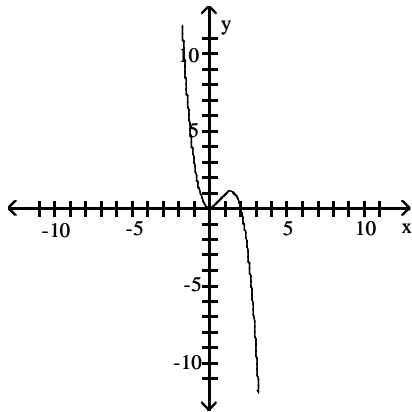

B)

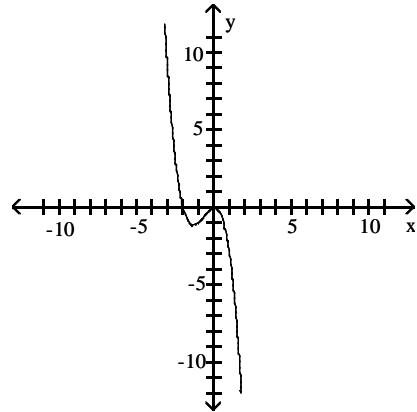

C)

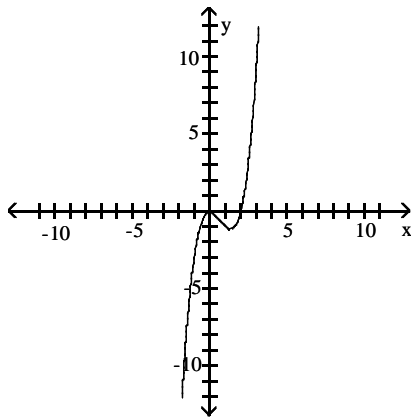

D)

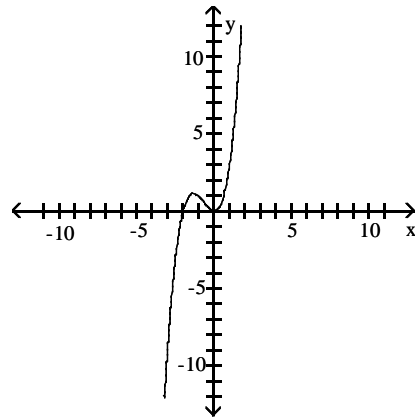

14) $y = \frac{1}{3} - \frac{1}{3}x^4$

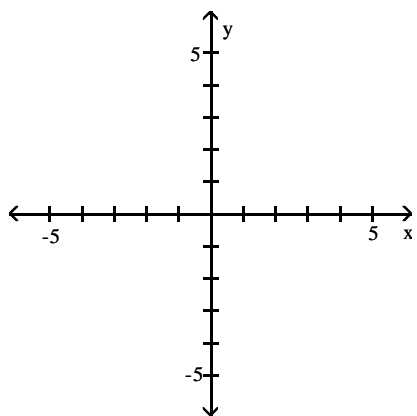

A)

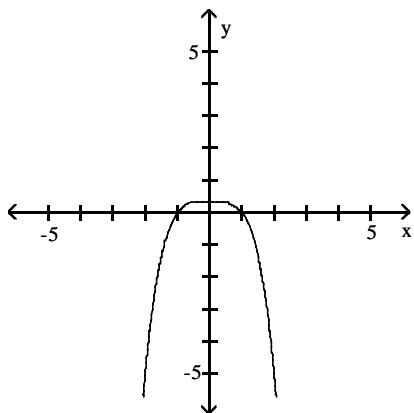

B)

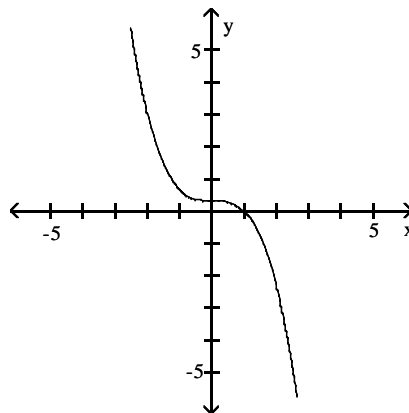

C)

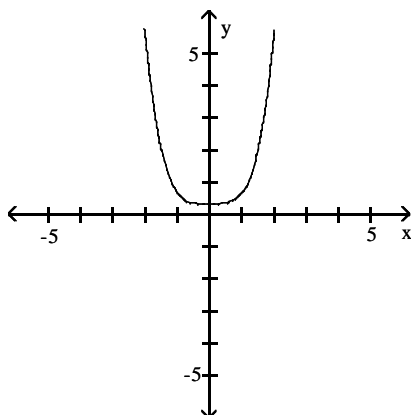

D)

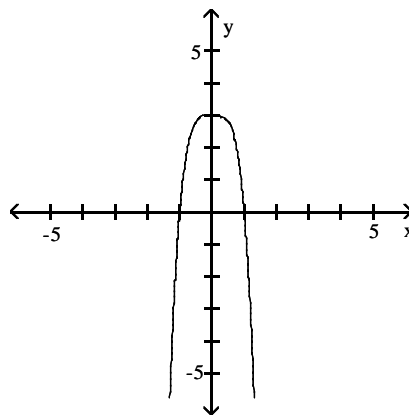

15) $y = x^3 + 5x^2 - x - 5$

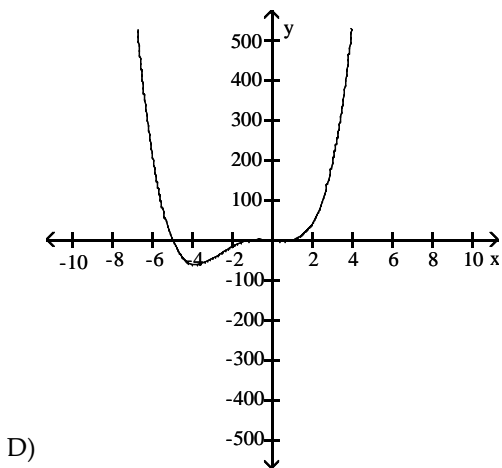
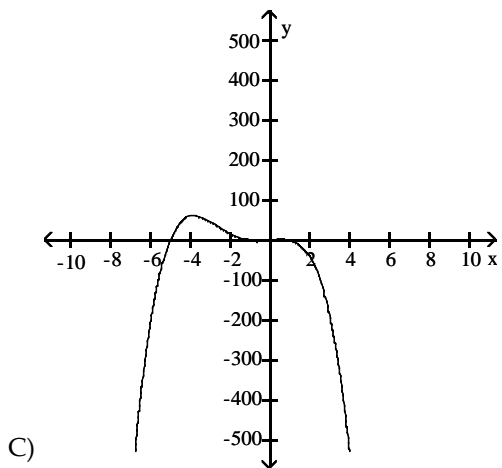
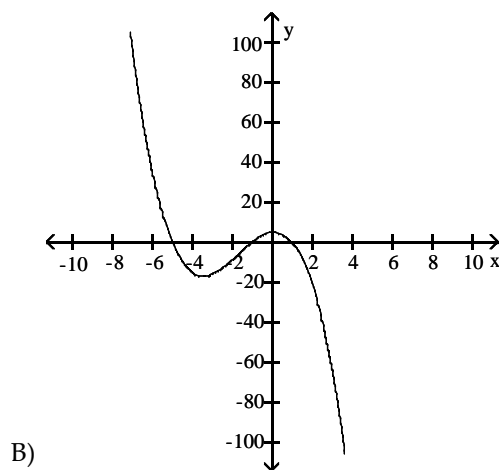
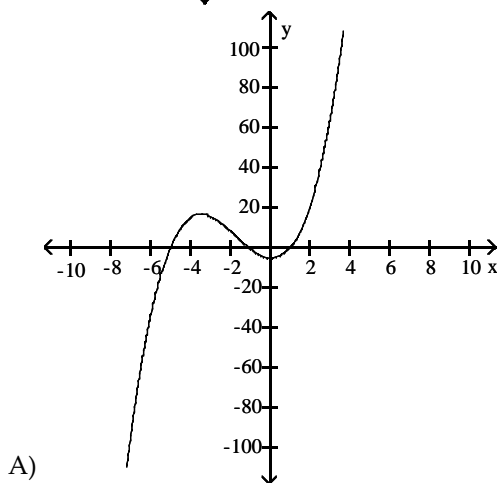
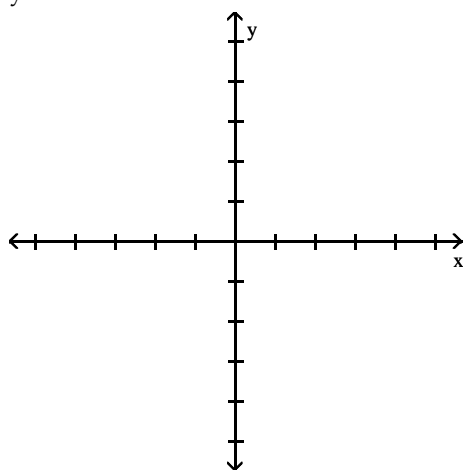

16) $y = x^3 + 2x^2 - 5x - 6$

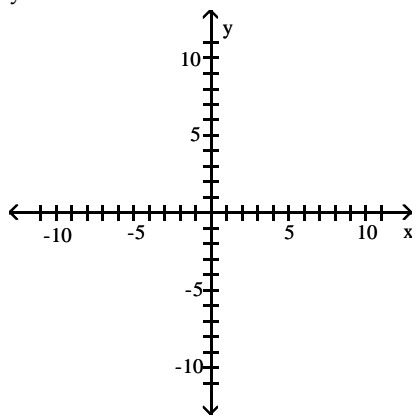

A)

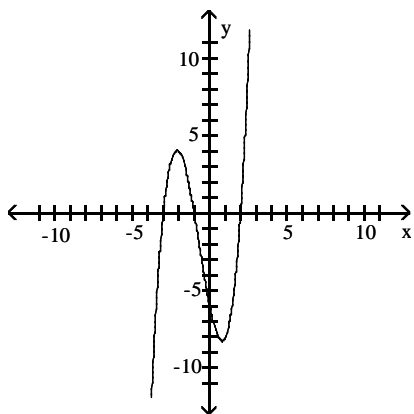

B)

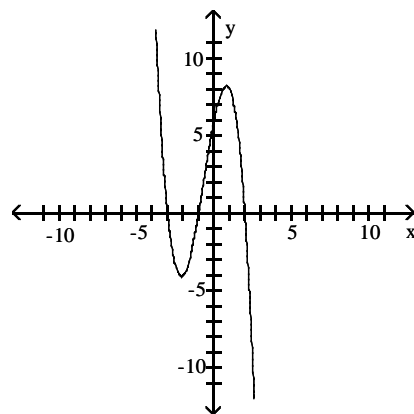

C)

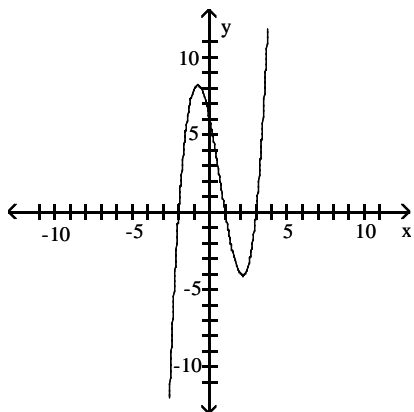

D)

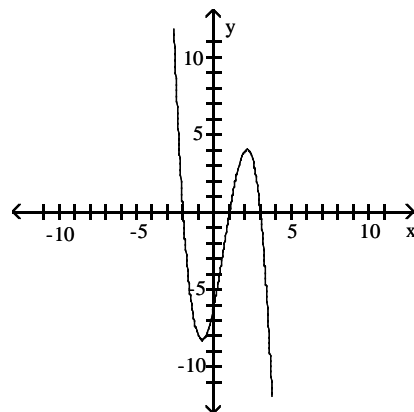

17) $y = 5x - x^3 - x^5$

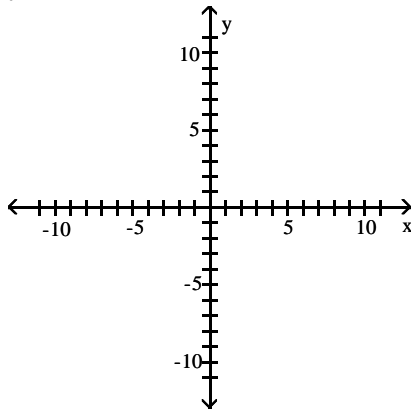

A)

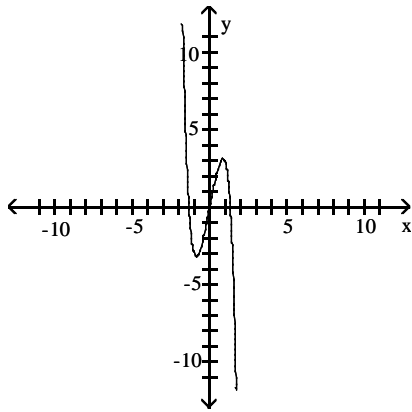

B)

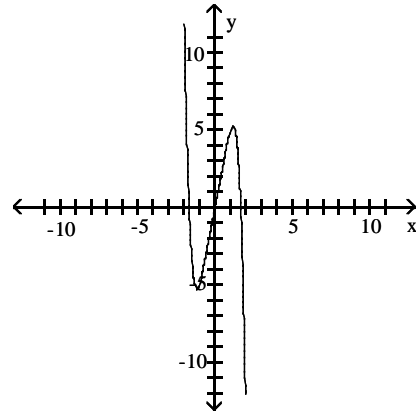

C)

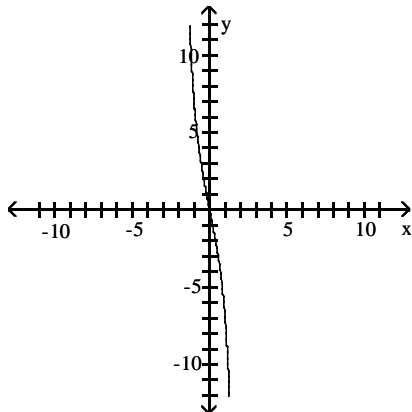

D)

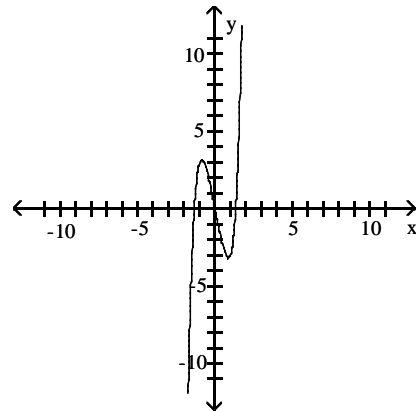

18) $y = 4x^4 + 4x^3$

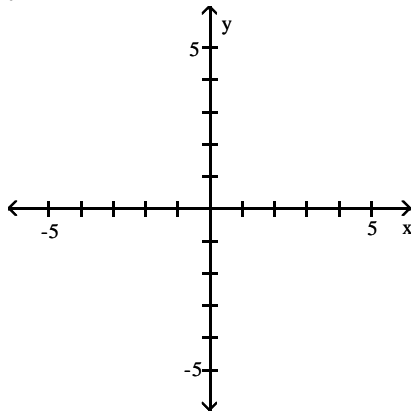

A)

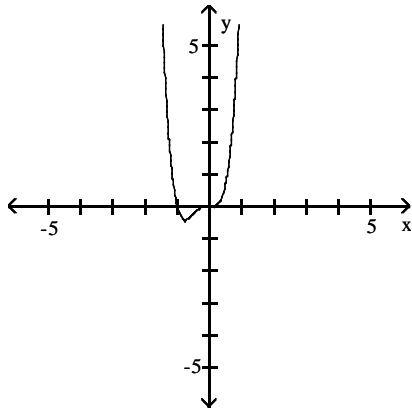

B)

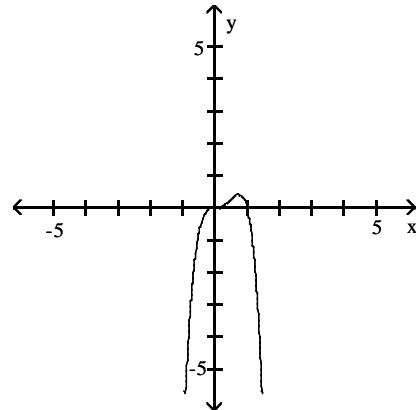

C)

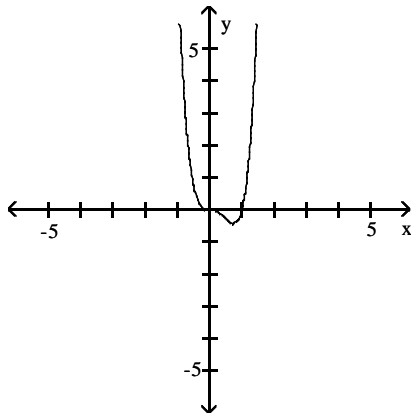

D)

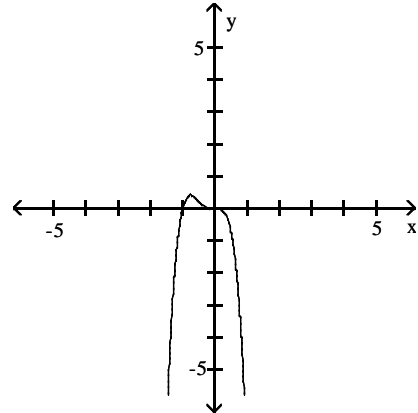

19) $y = 6x^3 - 5x - x^5$

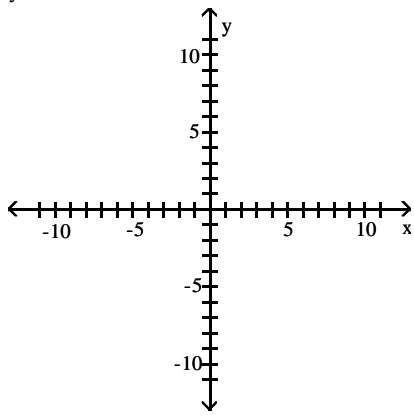

A)

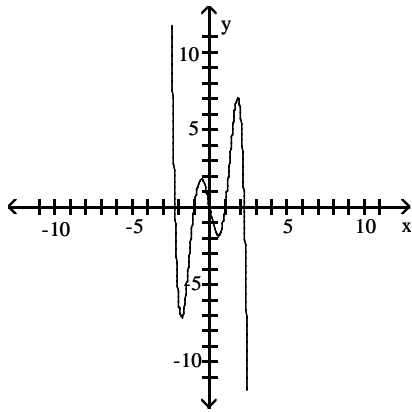

B)

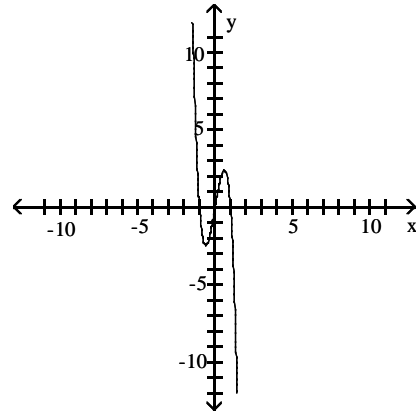

C)

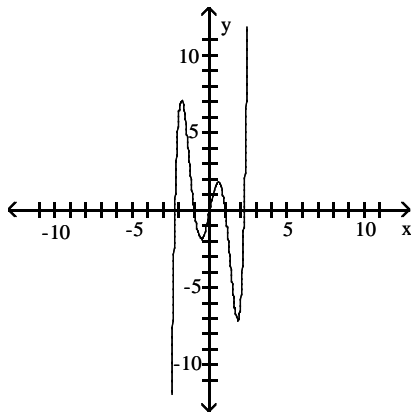

D)

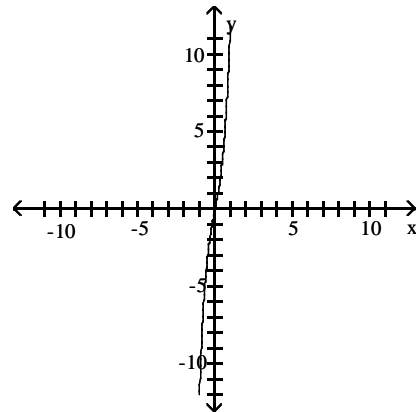

20) $y = x^4 + 12x^3 + 36x^2$

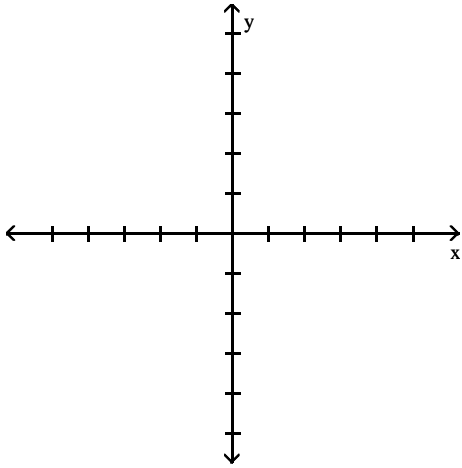

A)

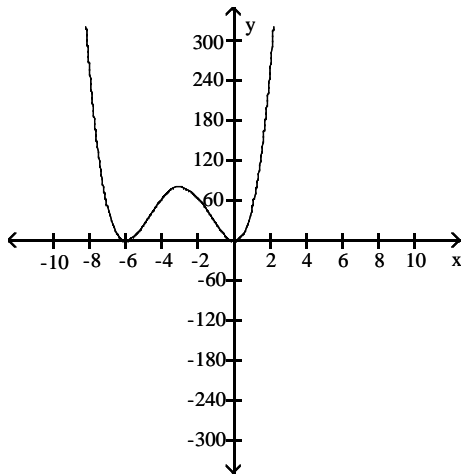

B)

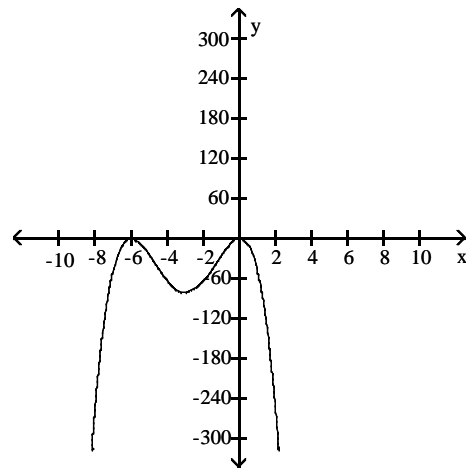

C)

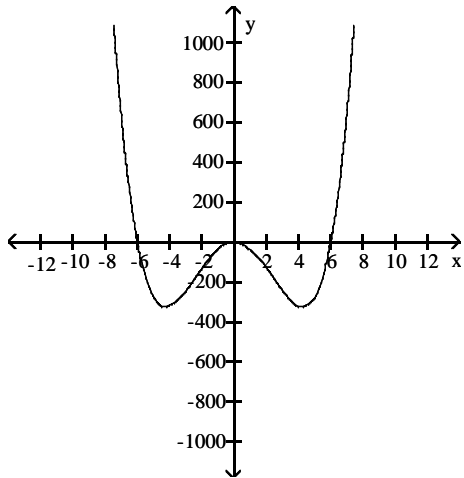

D)

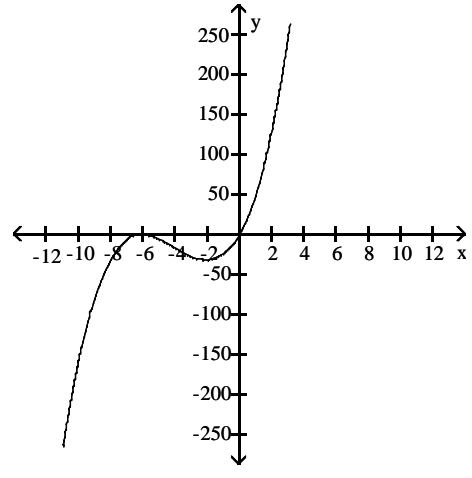

21) $y = x^5 - 4x^3 - 45x$

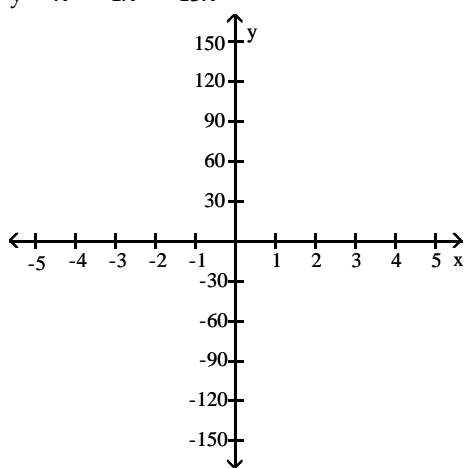

A)

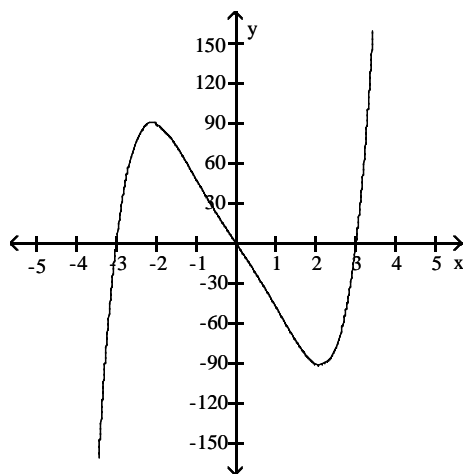

B)

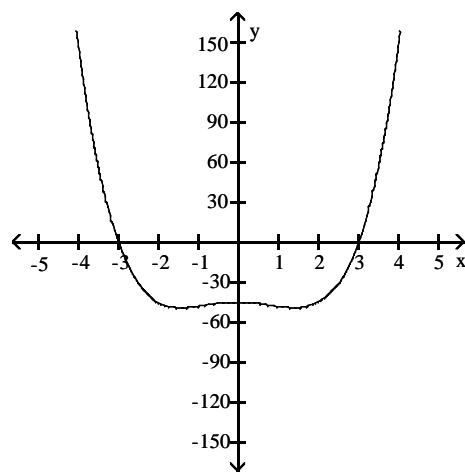

C)

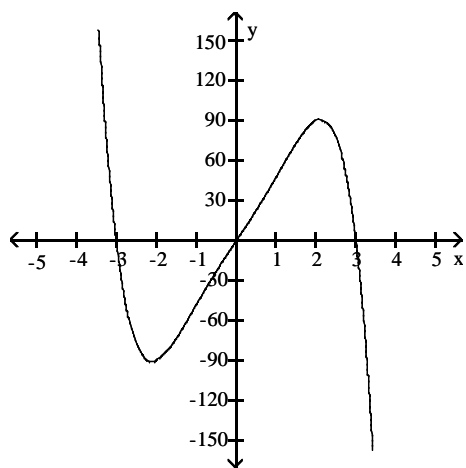

D)

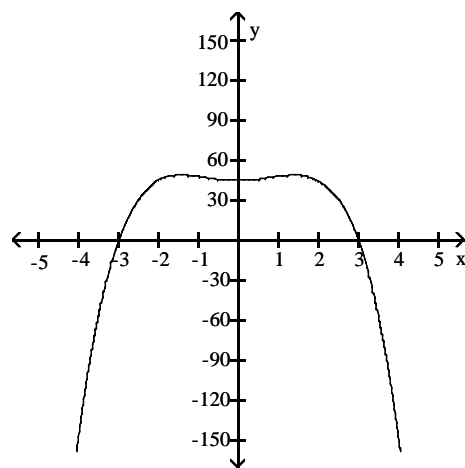

22) $y = x^4 - 2x^3 - x^2 + 2$

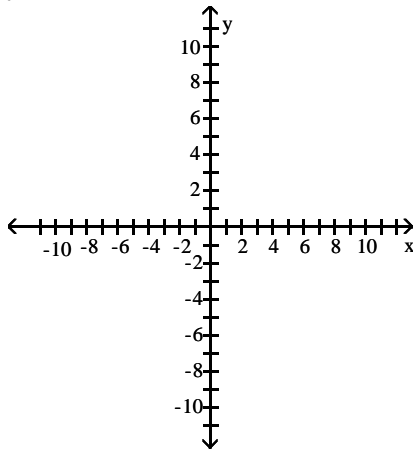

A)

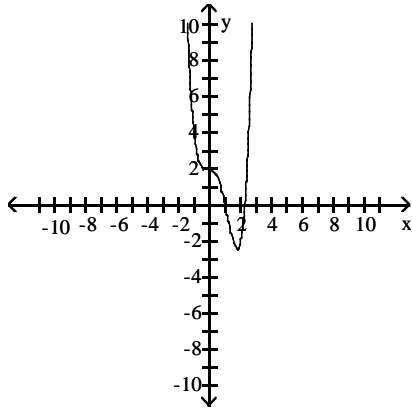

B)

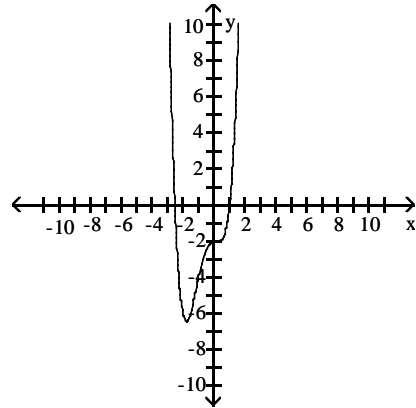

C)

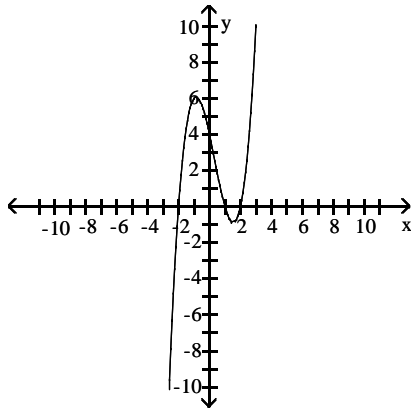

D)

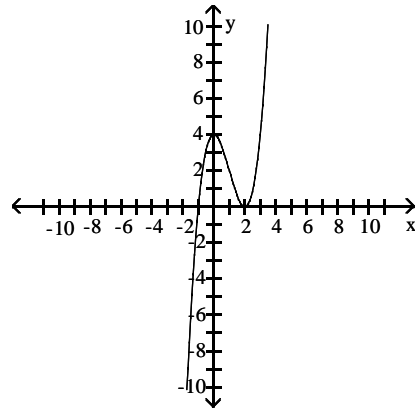

23) $y = x^4 + 6x^3 + 9x^2$

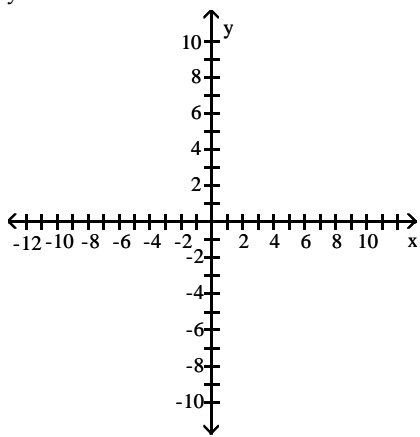

A)

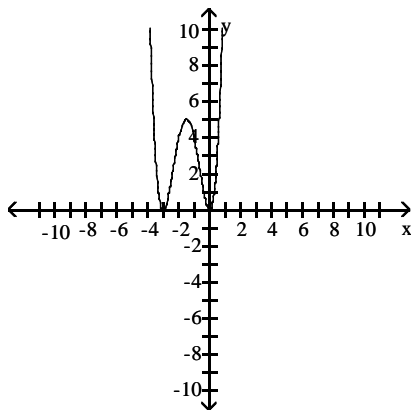

B)

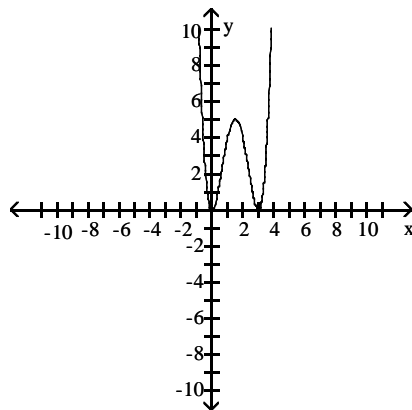

C)

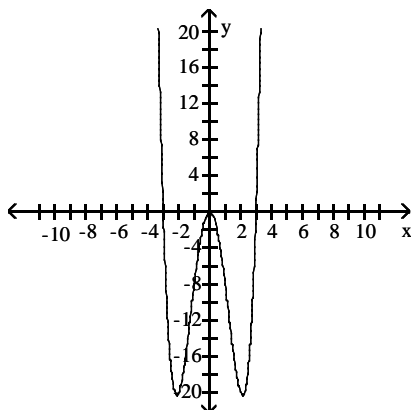

D)

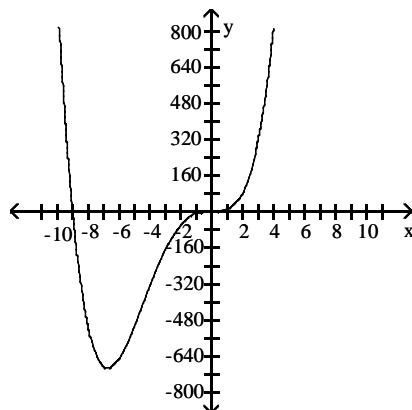

24) $y = -2x(x + 1)^3$

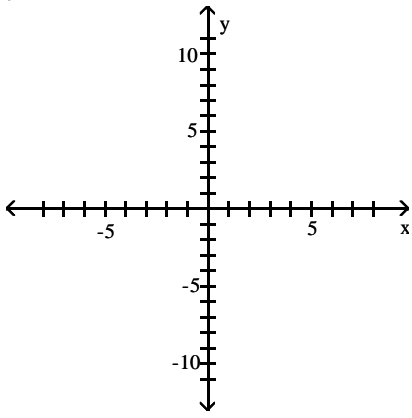

A)

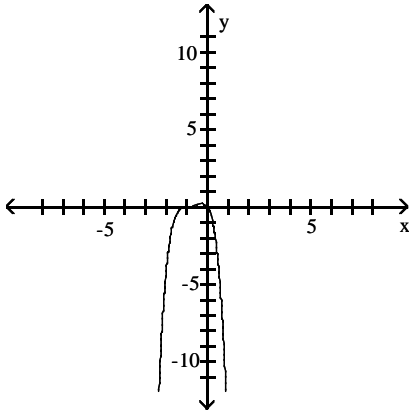

B)

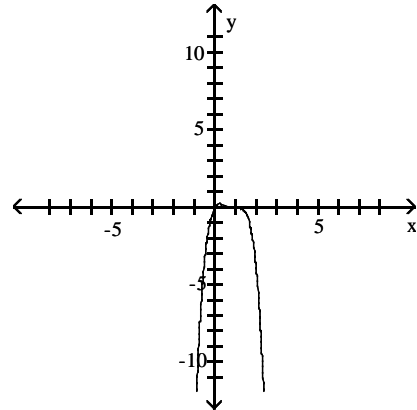

C)

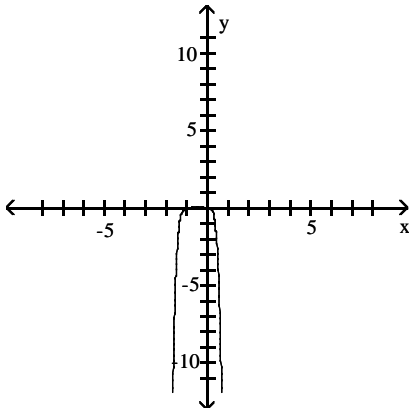

D)

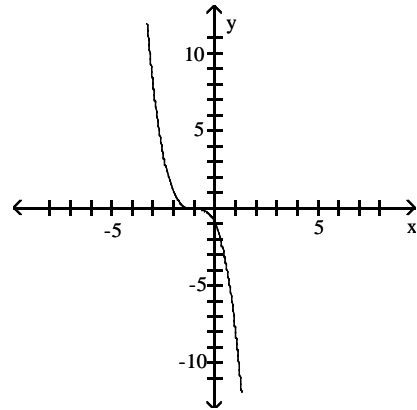

25) $y = x(x - 1)(x + 3)$

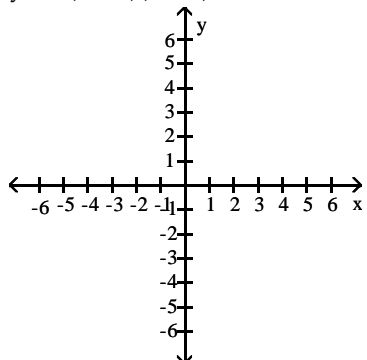

A)

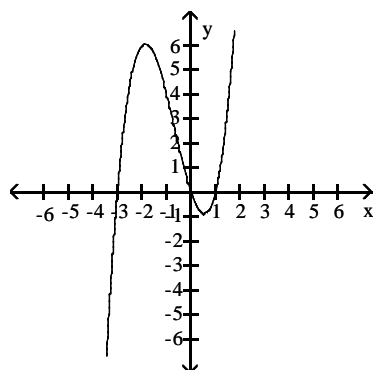

B)

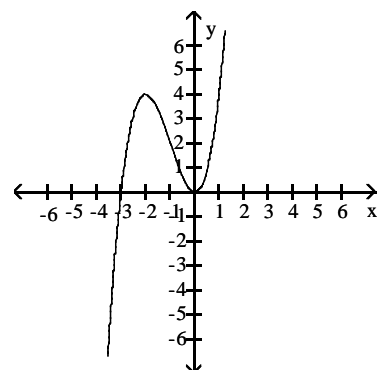

C)

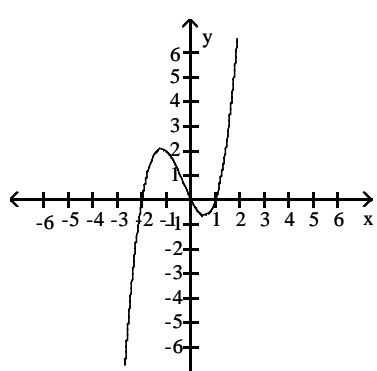

D)

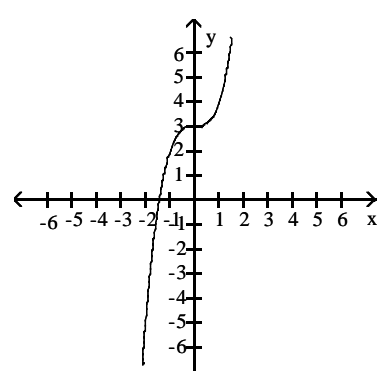

26) $y = -x^2(x - 2)(x + 2)$

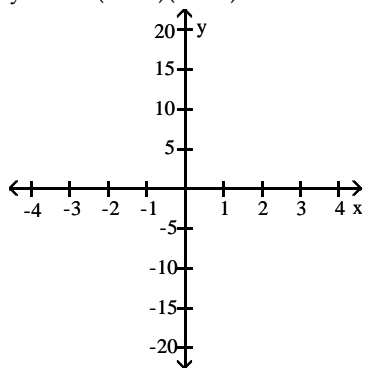

A)

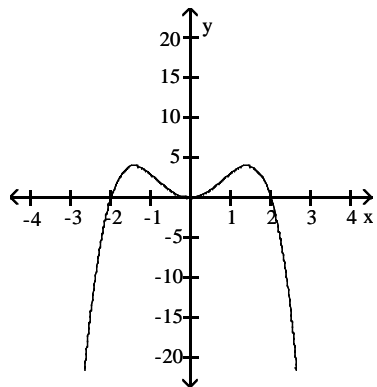

B)

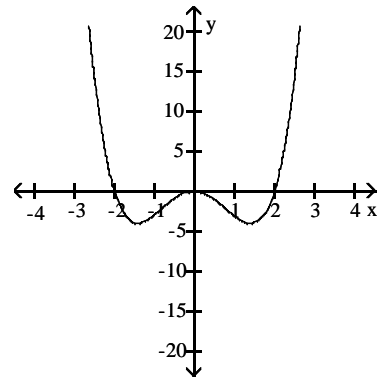

C)

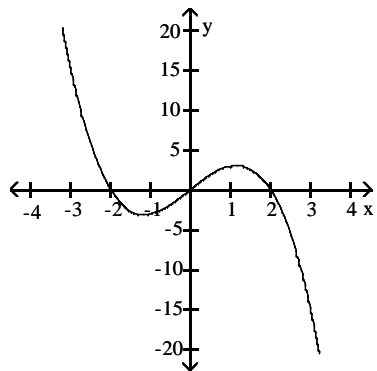

D)

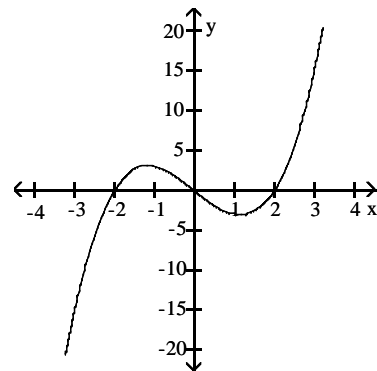

27) $y = (x + 1)^2(x^2 - 16)$

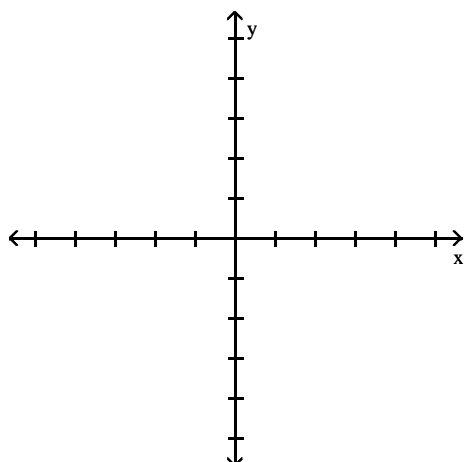

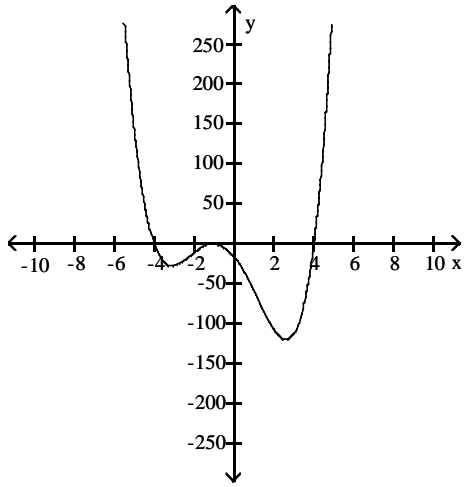

A)

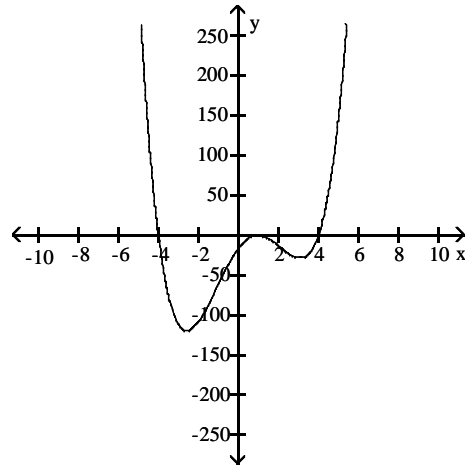

B)

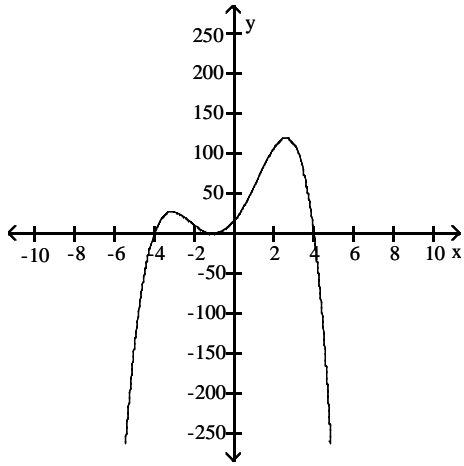

C)

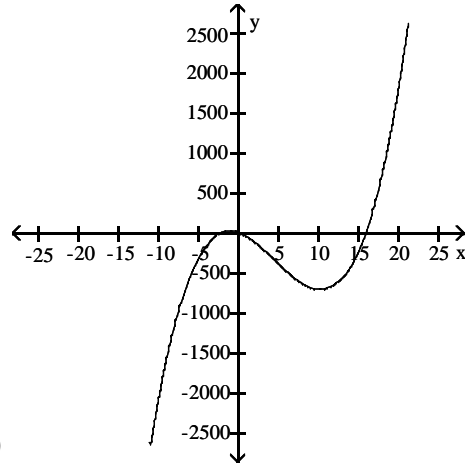

D)

28) $y = -x^2(x - 1)(x + 3)$

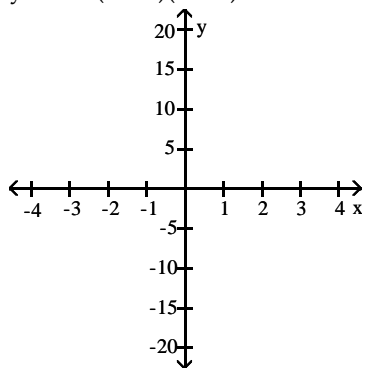

A)

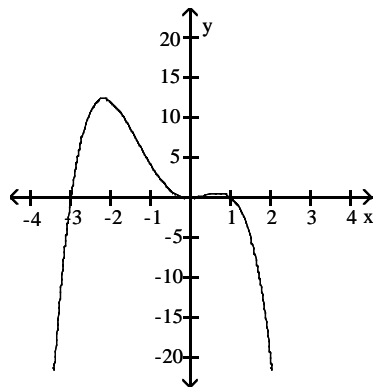

B)

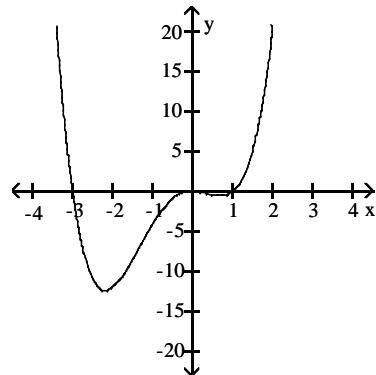

C)

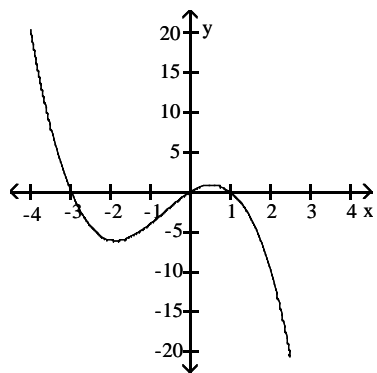

D)

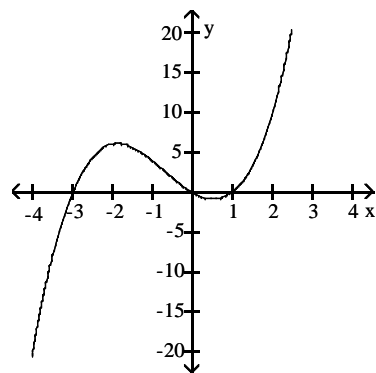

29) $y = -2x^3(x - 3)^2(x + 1)$

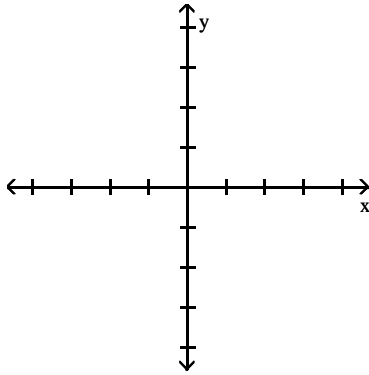

A)

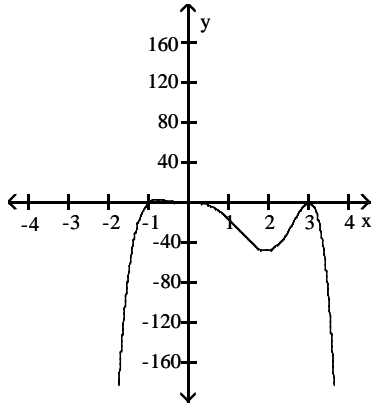

B)

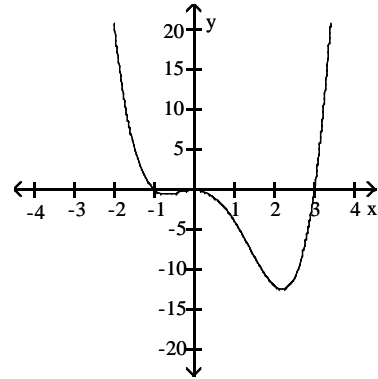

C)

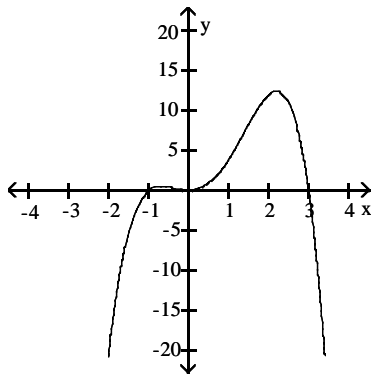

D)

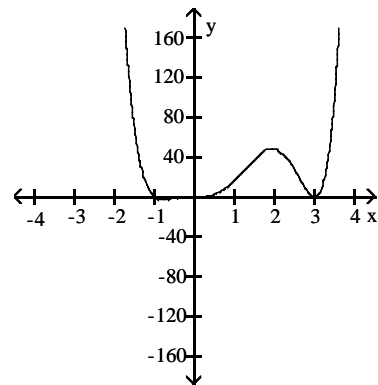

30) $y = (x - 3)(x - 1)(x + 1)$

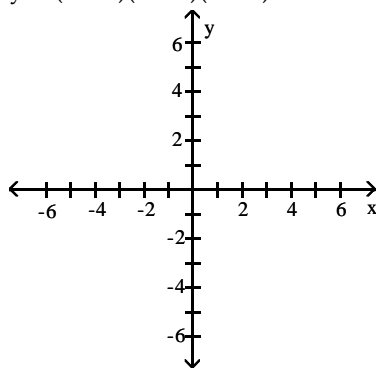

A)

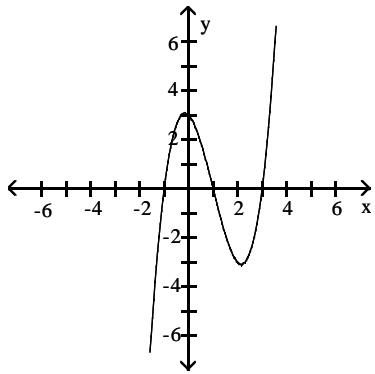

B)

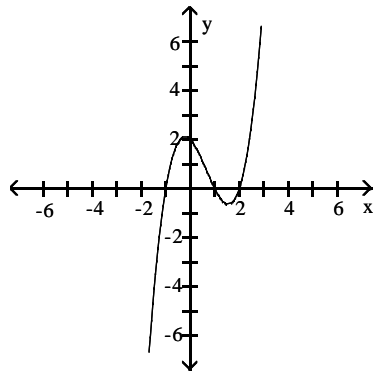

C)

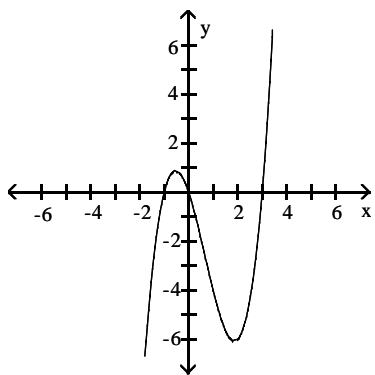

D)

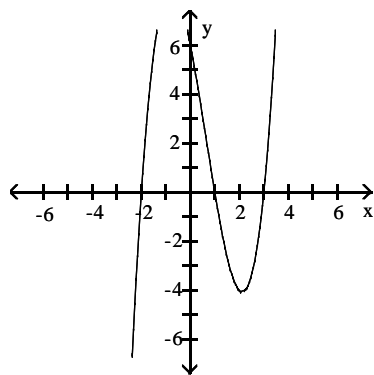

31) $y = (x + 2)(x + 3)(x + 5)^2$

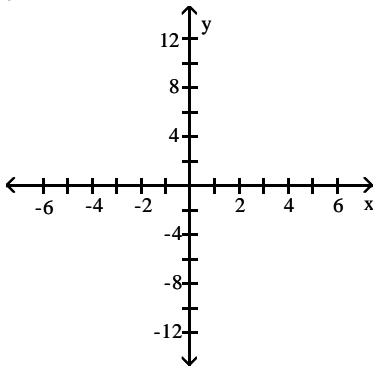

A)

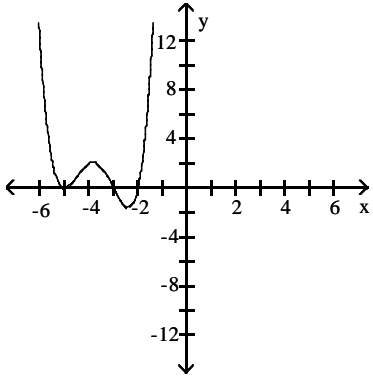

B)

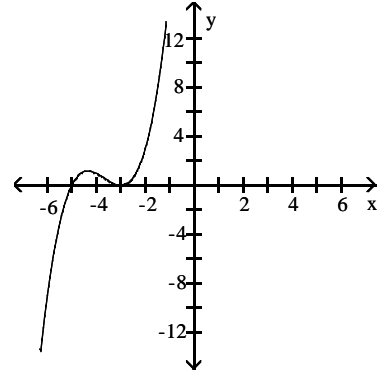

C)

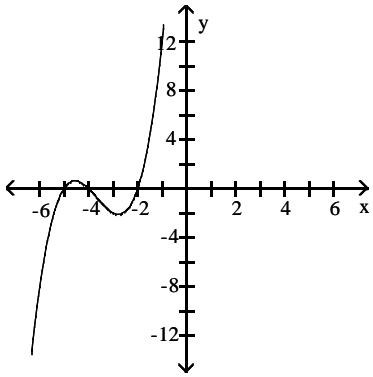

D)

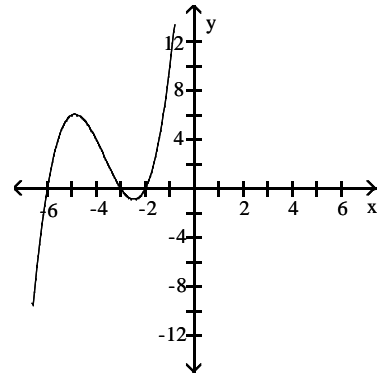

2 Tech: Graph Equation

MULTIPLE CHOICE. Choose the one alternative that best completes the statement or answers the question.

Use your graphing calculator to obtain the graph of the equation.

1) $y = (x + 1)^3 - 3$

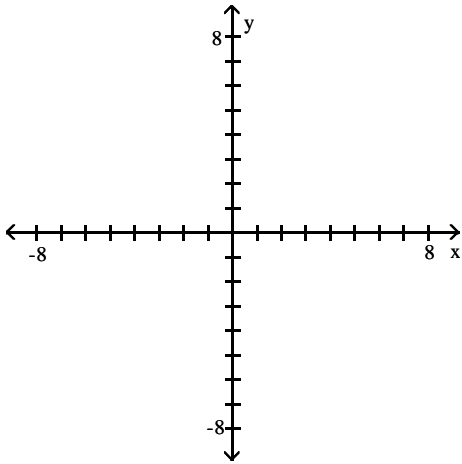

A)

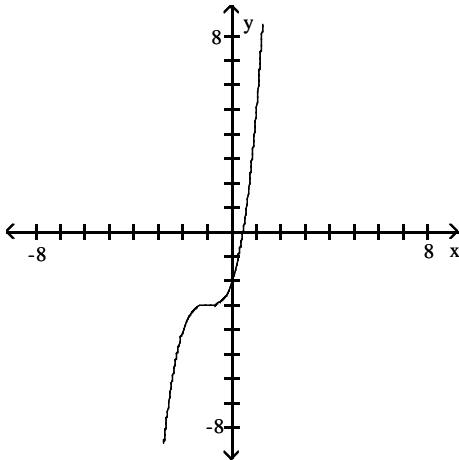

B)

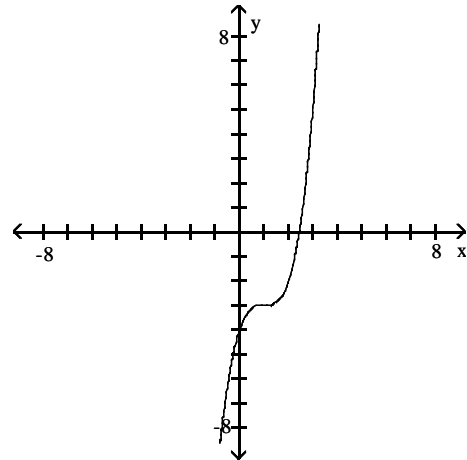

C)

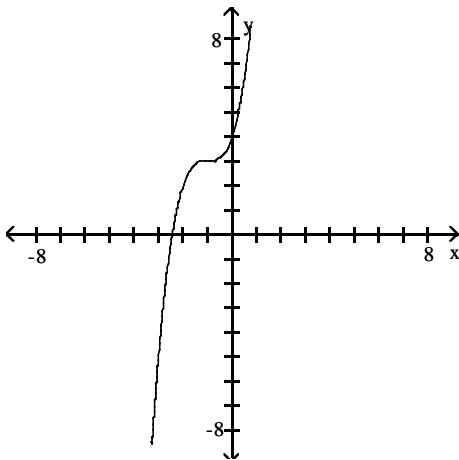

D)

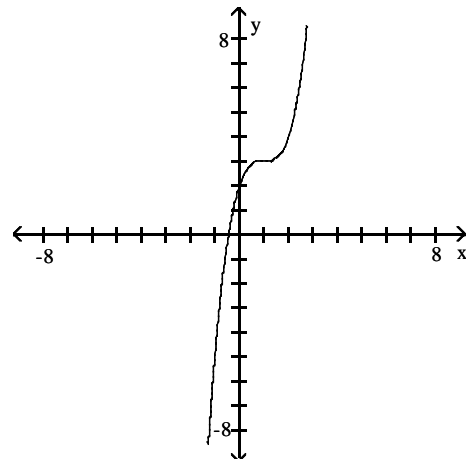

2) $y = -(x - 3)^4 - 5$

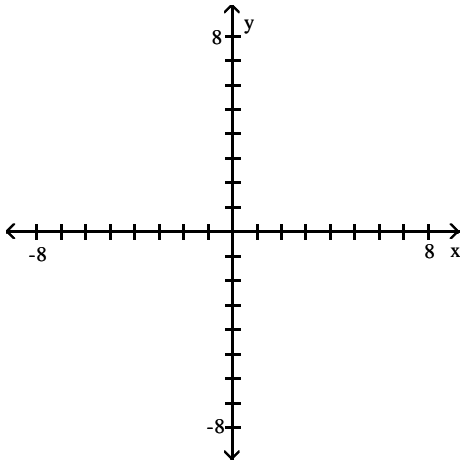

A)

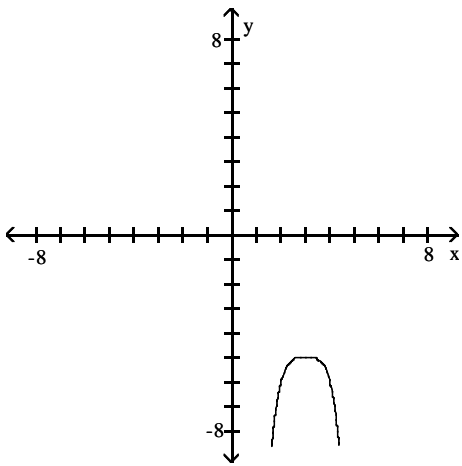

C)

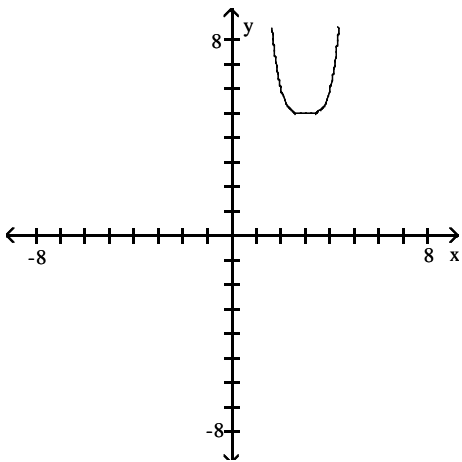

B)

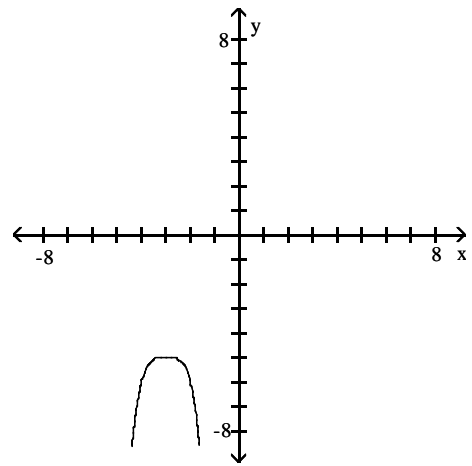

D)

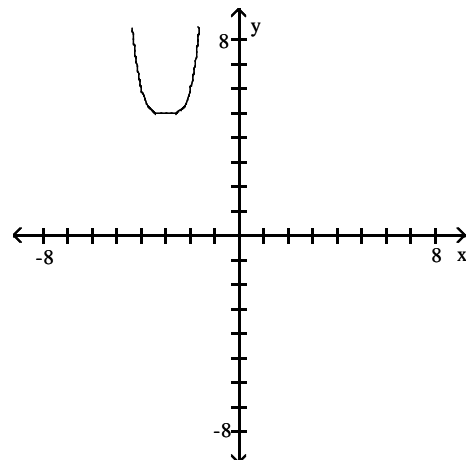

3) $y = x^3 - 3x + 2$

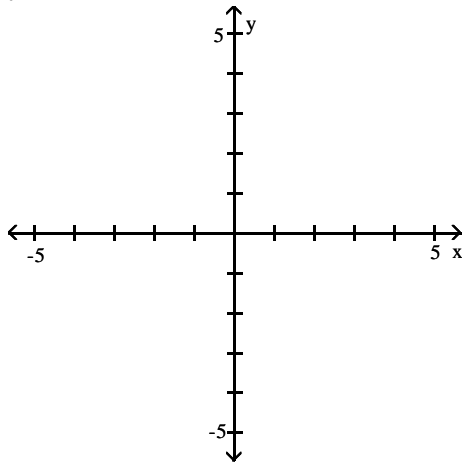

A)

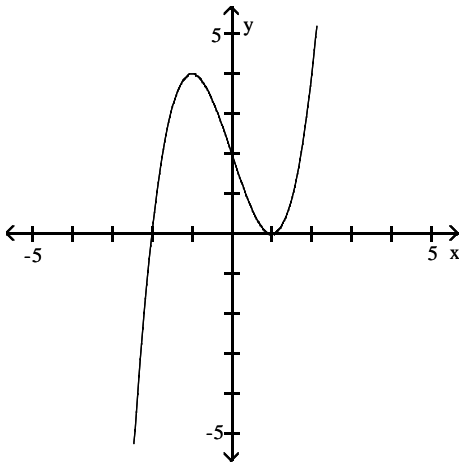

B)

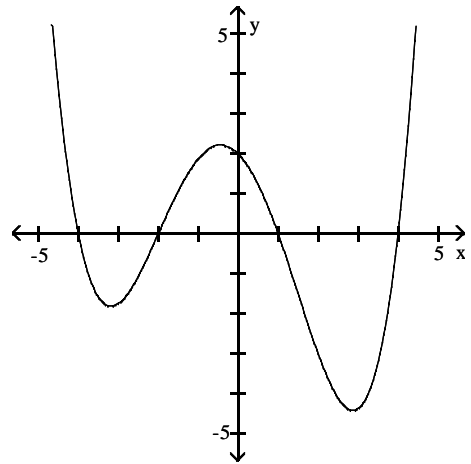

C)

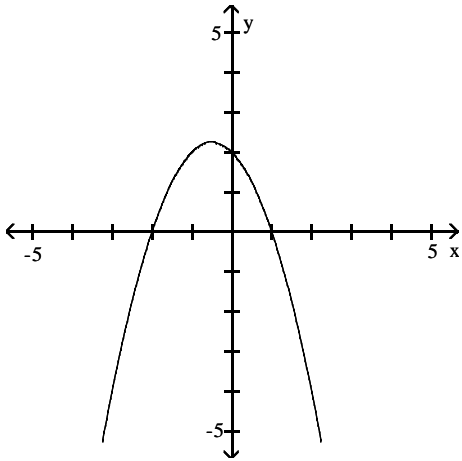

D)

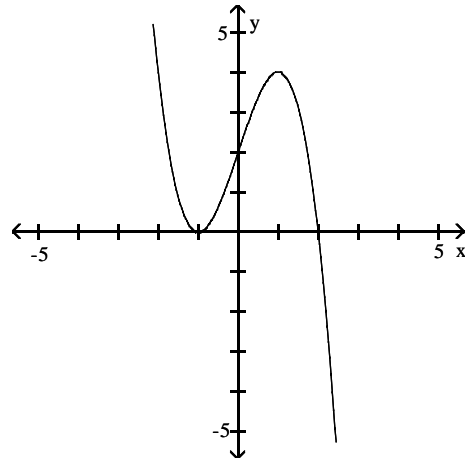

4) $y = x^4 + x^3 - 5x^2 - 4x + 4$

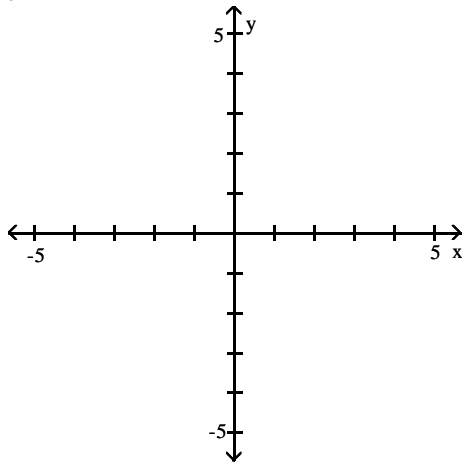

A)

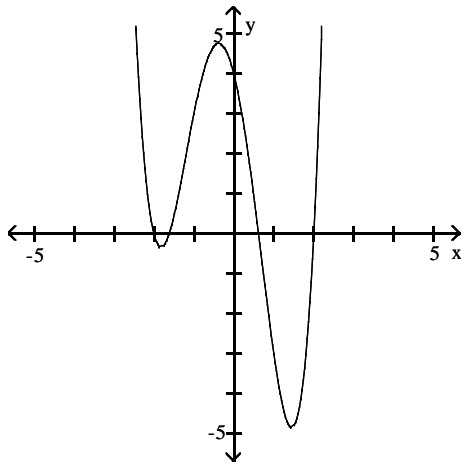

B)

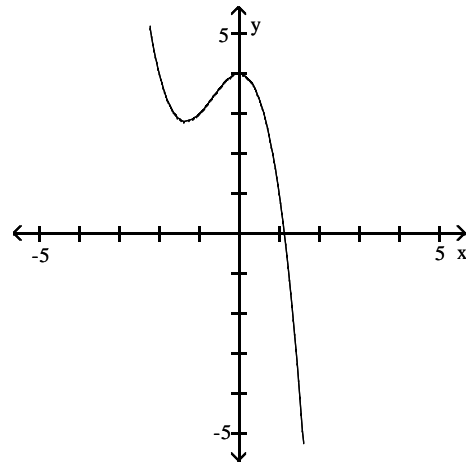

C)

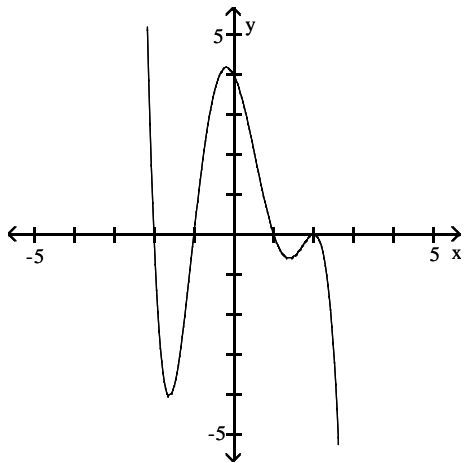

D)

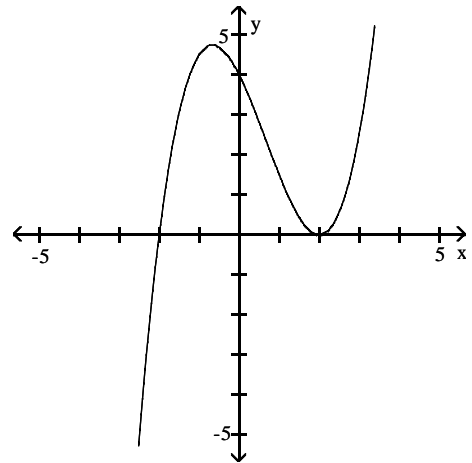

5) $y = \frac{3}{x+2}$

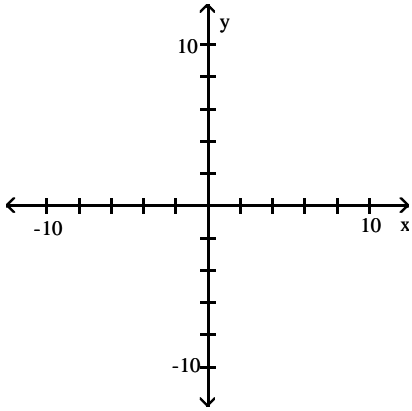

A)

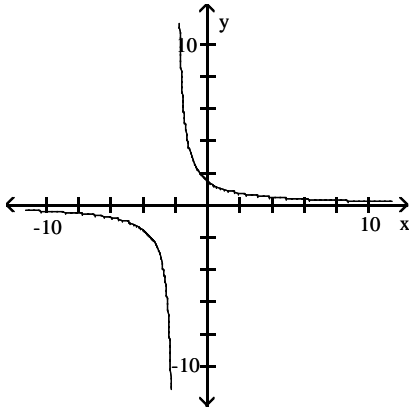

B)

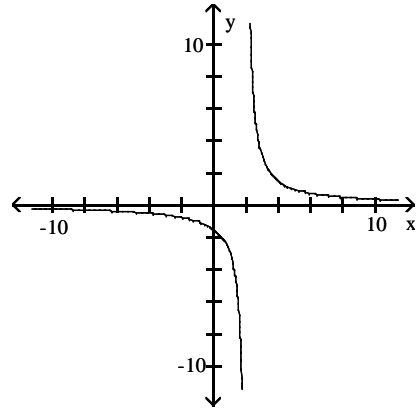

C)

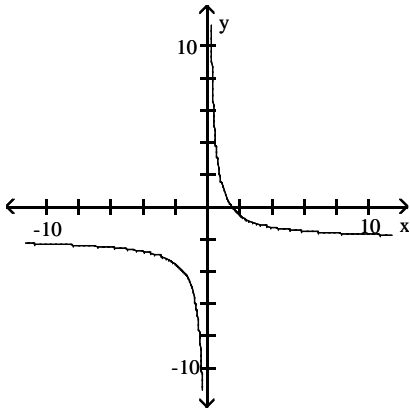

D)

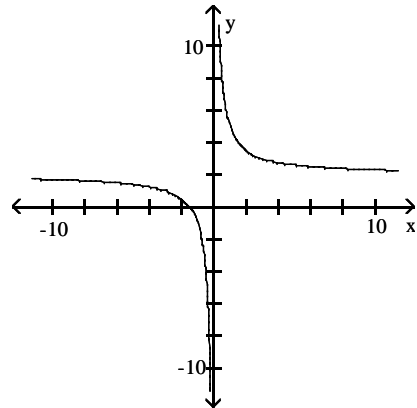

6) $y = \frac{3}{x-3}$

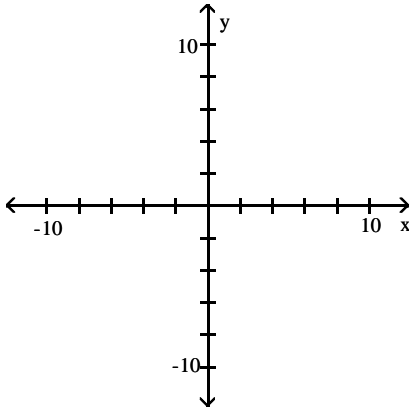

A)

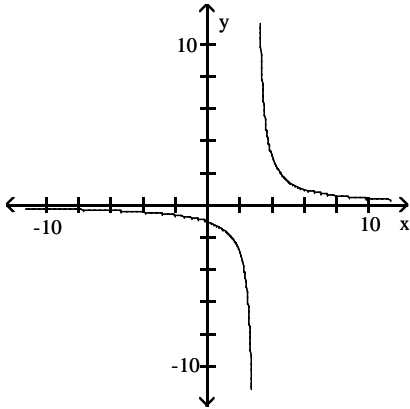

B)

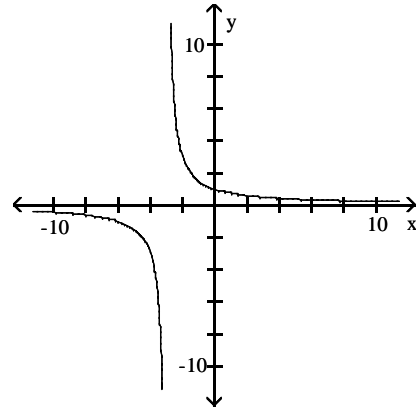

C)

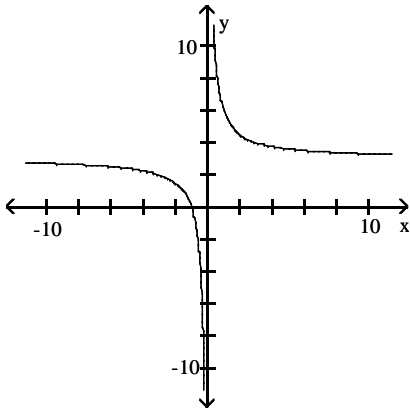

D)

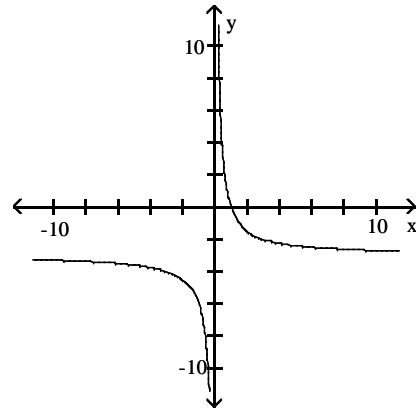

$$7) y = \frac{1}{(x+2)^2}$$

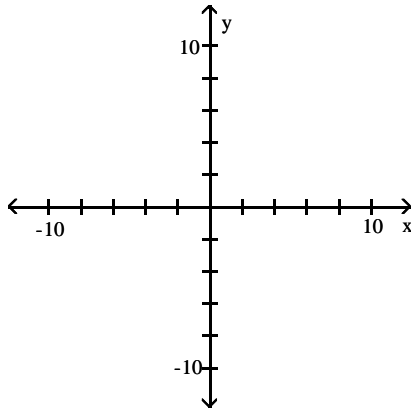

A)

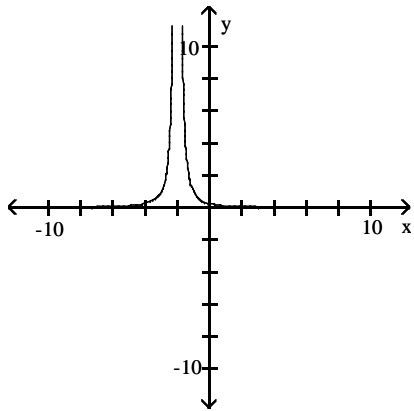

B)

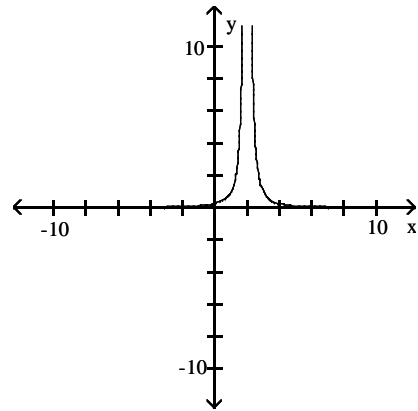

C)

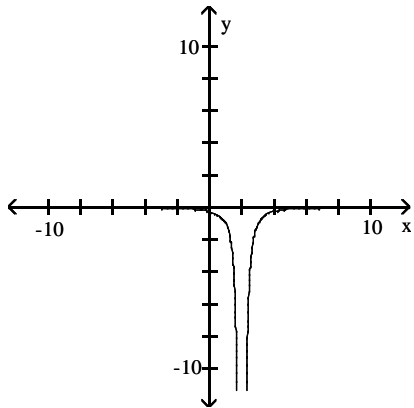

D)

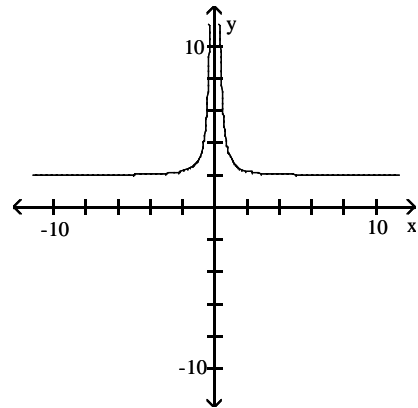

8) $y = \frac{4}{x^2}$

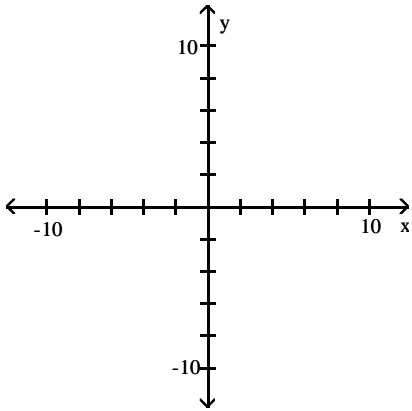

A)

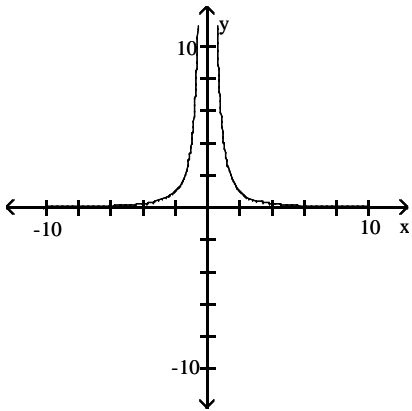

B)

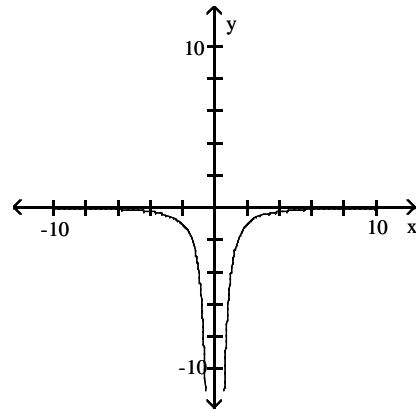

C)

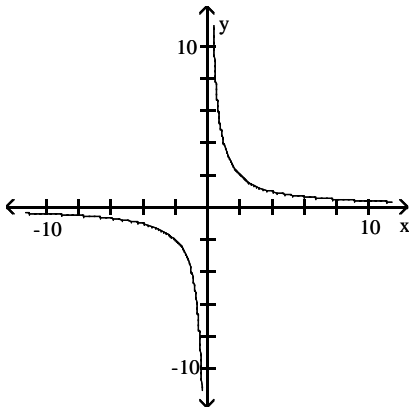

D)

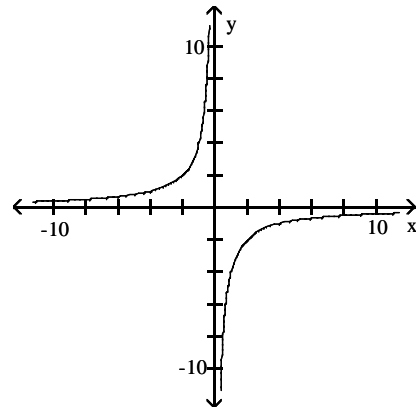

9) Graph the upper half of the circle defined by the equation $x^2 + y^2 - 10x - 6y + 25 = 0$.

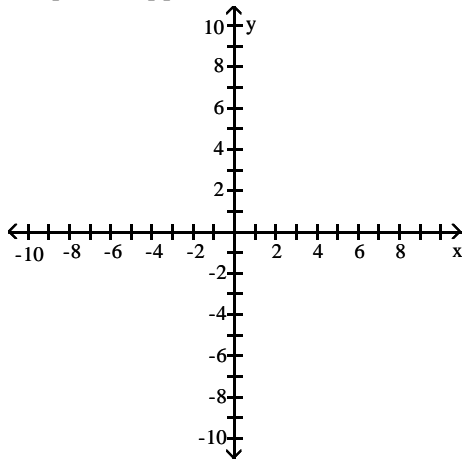

A)

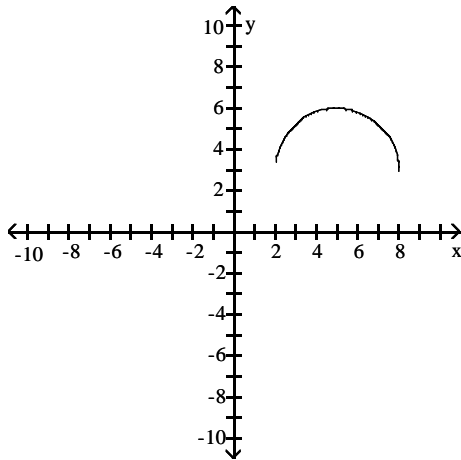

B)

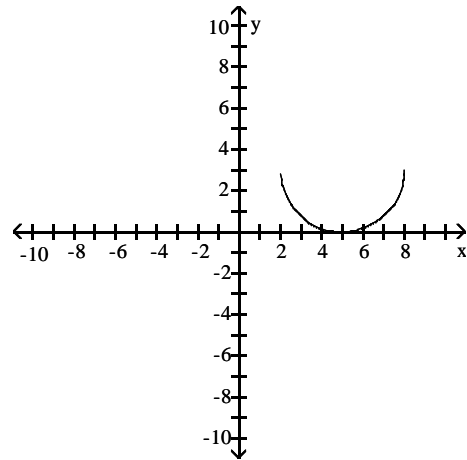

C)

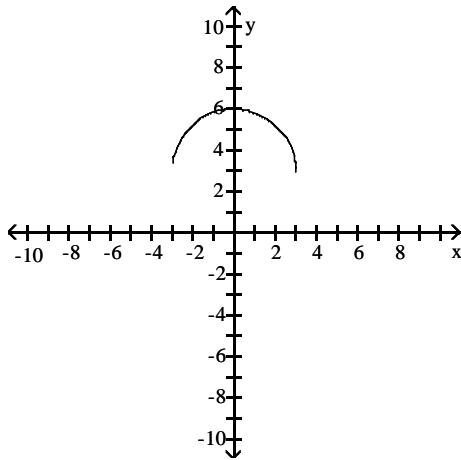

D)

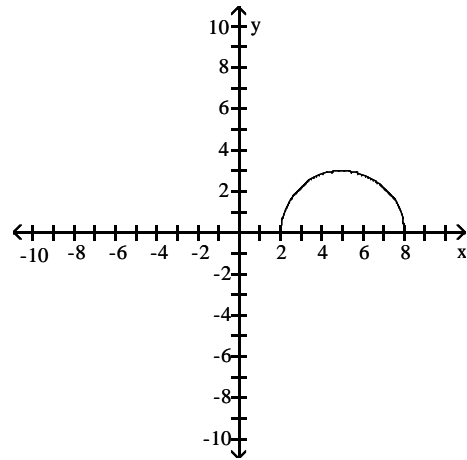

3 Find Points of Intersection

MULTIPLE CHOICE. Choose the one alternative that best completes the statement or answers the question.

Graph the two equations and find the points at which the graphs intersect.

1) $y = 3x$, $x^2 + y^2 = 16$

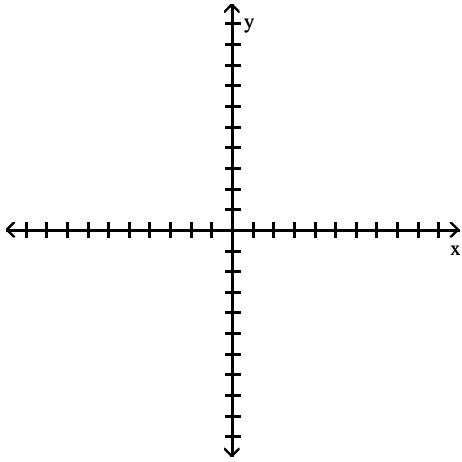

A) $\left(\frac{4}{\sqrt{10}}, \frac{12}{\sqrt{10}}\right), \left(-\frac{4}{\sqrt{10}}, -\frac{12}{\sqrt{10}}\right)$
 C) $\left(\frac{4}{\sqrt{10}}, -\frac{12}{\sqrt{10}}\right), \left(-\frac{4}{\sqrt{10}}, \frac{12}{\sqrt{10}}\right)$

B) $\left(\frac{4}{\sqrt{10}}, \frac{12}{\sqrt{10}}\right)$
 D) $\left(\frac{4}{3}, 4\right), \left(-\frac{4}{3}, -4\right)$

2) $x + y = 7$, $(x - 7)^2 + y^2 = 2$

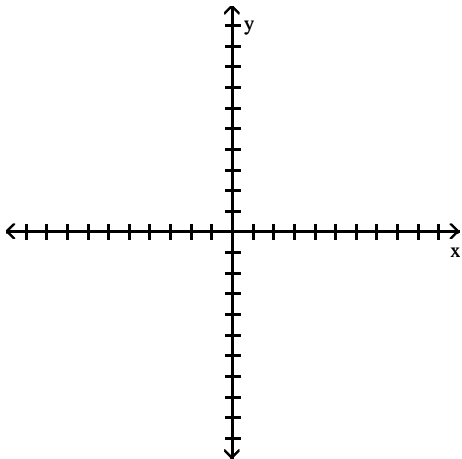

A) $(8, -1), (6, 1)$

B) $(8, 1), (6, -1)$

C) $(1, -1), (-1, 1)$

D) $(-8, 15), (-6, 13)$

3) $x + y = 0, \quad y = -(x - 4)^2$

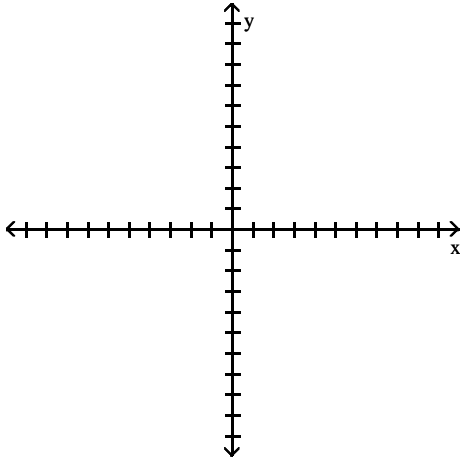

A) $\left\{ \frac{9 - \sqrt{17}}{2}, \frac{-9 + \sqrt{17}}{2} \right\}, \left\{ \frac{9 + \sqrt{17}}{2}, \frac{-9 - \sqrt{17}}{2} \right\}$
 C) $\left\{ \frac{-9 + \sqrt{17}}{2}, \frac{9 - \sqrt{17}}{2} \right\}, \left\{ \frac{-9 - \sqrt{17}}{2}, \frac{9 + \sqrt{17}}{2} \right\}$

B) $\left\{ \frac{9 - \sqrt{17}}{2}, \frac{-9 - \sqrt{17}}{2} \right\}, \left\{ \frac{9 + \sqrt{17}}{2}, \frac{-9 + \sqrt{17}}{2} \right\}$
 D) $\left\{ \frac{9 - \sqrt{17}}{2}, \frac{9 - \sqrt{17}}{2} \right\}, \left\{ \frac{9 + \sqrt{17}}{2}, \frac{9 + \sqrt{17}}{2} \right\}$

4) $y = \frac{1}{4}x^2, \quad y = (x - 2)^2$

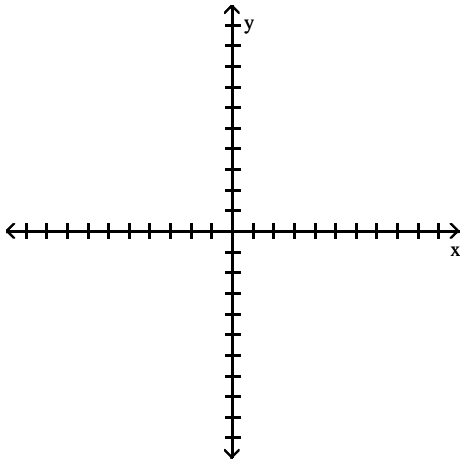

A) $(4, 4), \left(\frac{4}{3}, \frac{4}{9}\right)$

B) $(4, \frac{4}{9}), \left(\frac{4}{3}, 4\right)$

C) $(2, 4), \left(\frac{2}{3}, \frac{4}{9}\right)$

D) $(4, 4), \left(\frac{4}{9}, \frac{4}{3}\right)$

5) $x^2 + y^2 = 4$, $x^2 + (y - 3)^2 = 4$

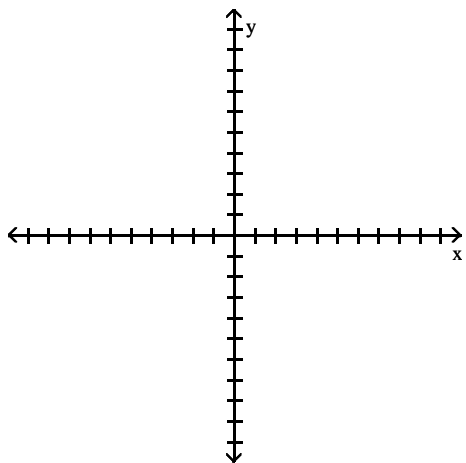

A) $\left(-\frac{\sqrt{7}}{2}, \frac{3}{2}\right), \left(\frac{\sqrt{7}}{2}, \frac{3}{2}\right)$
 C) $\left(-\frac{\sqrt{7}}{2}, -\frac{3}{2}\right), \left(\frac{\sqrt{7}}{2}, -\frac{3}{2}\right)$

B) $\left(\frac{3}{2}, -\frac{\sqrt{7}}{2}\right), \left(\frac{3}{2}, \frac{\sqrt{7}}{2}\right)$
 D) $\left(-\frac{\sqrt{7}}{2}, -\frac{3}{2}\right), \left(\frac{\sqrt{7}}{2}, \frac{3}{2}\right)$

6) $x^2 + y^2 = 9$, $x^2 + y = 9$

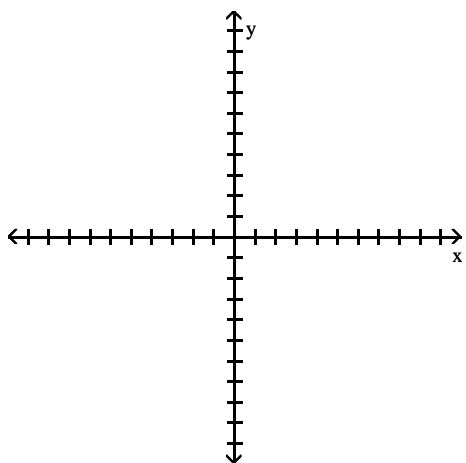

A) $(-3, 0), (3, 0)$

B) $(-3, 0), (3, 0), (0, 3)$

C) $(0, -3), (0, 3)$

D) $(3, 0), (0, -3), (0, 3)$

4 Match General Equation to Graph

MULTIPLE CHOICE. Choose the one alternative that best completes the statement or answers the question.

Choose the equation that corresponds to the graph.

1)

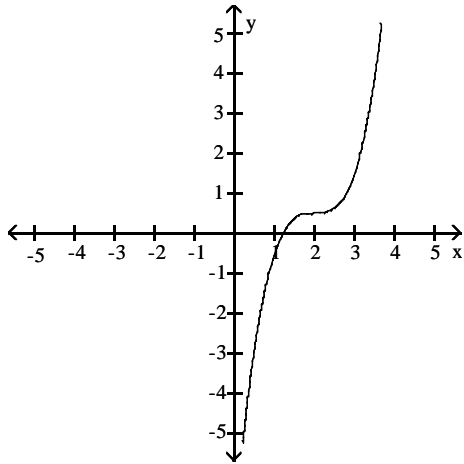

A) $y = ax^3$, with $a > 0$

B) $y = ax^2$, with $a > 0$

C) $y = ax^3$, with $a < 0$

D) $y = ax^2$, with $a < 0$

2)

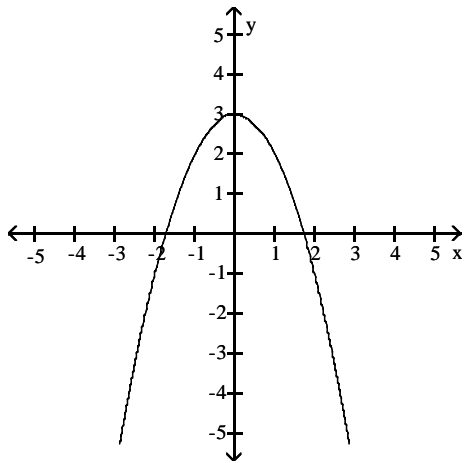

A) $y = ax^2$, with $a < 0$

B) $y = ax^3$, with $a > 0$

C) $y = ax^2$, with $a > 0$

D) $y = ax^3$, with $a < 0$

3)

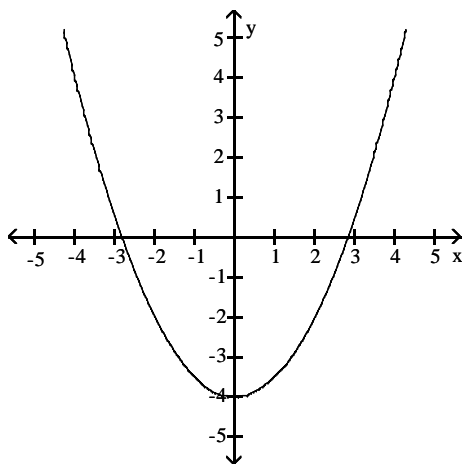

- A) $y = ax^2$, with $a > 0$ B) $y = ax^3$, with $a > 0$ C) $y = ax^2$, with $a < 0$ D) $y = ax^3$, with $a < 0$

4)

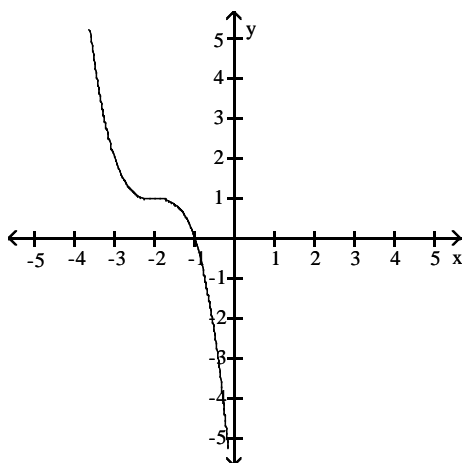

- A) $y = ax^3$, with $a < 0$ B) $y = ax^2$, with $a > 0$ C) $y = ax^3$, with $a > 0$ D) $y = ax^2$, with $a < 0$

5)

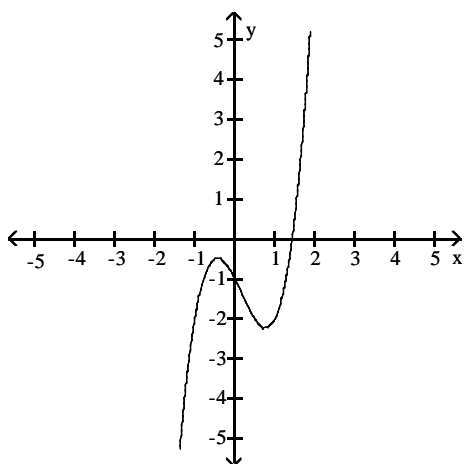

- A) $y = ax^3 + bx^2 + cx + d$, with $a > 0$ B) $y = ax^3$, with $a > 0$
 C) $y = ax^3$, with $a < 0$ D) $y = ax^3 + bx^2 + cx + d$, with $a < 0$

6)

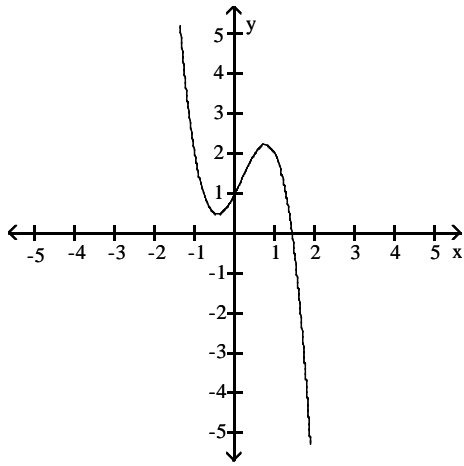

A) $y = ax^3 + bx^2 + cx + d$, with $a < 0$

B) $y = ax^3$, with $a < 0$

C) $y = ax^3 + bx^2 + cx + d$, with $a > 0$

D) $y = ax^3$, with $a > 0$

5 Find Distance Between Two Points on a Circle

MULTIPLE CHOICE. Choose the one alternative that best completes the statement or answers the question.

Find the distances between the given points on the circle.

1) Find all the distances between the points on the circle $x^2 + y^2 = 4$ with the x -coordinates -1 and 1 .

A) $2, 2\sqrt{3}, 4$

B) $1, \sqrt{3}, 2$

C) $2, 4\sqrt{3}, 5$

D) $2\sqrt{3}$

2) Find all the distances between the points on the circle $x^2 + y^2 = 9$ with the x -coordinates -2 and 2 .

A) $4, 2\sqrt{5}, 6$

B) $4, \sqrt{5}, 8$

C) $3, 5\sqrt{2}$

D) $\sqrt{10}, \sqrt{5}, \sqrt{2}$

0.5 Functions and Their Graphs

1 Evaluate Function

MULTIPLE CHOICE. Choose the one alternative that best completes the statement or answers the question.

Evaluate the function.

1) For $f(x) = -4x - 33$, find $f(-9)$.

A) 3

B) 2

C) -33

D) 132

2) For $f(x) = -3x - 22$, find $f(-8)$.

A) 2

B) -8

C) 4

D) -22

3) For $f(x) = x^2 + 4x + 4$, find $f(-3)$.

A) 1

B) -7

C) 17

D) 25

4) For $f(x) = x^2 - 3x - 1$, find $f(0)$.

A) -1

B) 1

C) 0

D) 1

5) For $f(x) = 2x^2 - 3x + 2$, find $f(3)$.

A) 11

B) 29

C) 7

D) 2

6) For $f(x) = \frac{6x - 4}{4x^2 - 8x - 9}$, find $f(-4)$.

A) $-\frac{28}{87}$

B) $\frac{20}{87}$

C) $-\frac{20}{87}$

D) $-\frac{28}{41}$

7) For $f(x) = \sqrt{4x - 14}$, find $f(13)$.

A) $\sqrt{38}$

B) $\sqrt{39}$

C) $\sqrt{37}$

D) $2\sqrt{37}$

8) For $g(x) = \sqrt{x^2 - 20}$, find $g(7)$.

A) $\sqrt{29}$

B) $\sqrt{30}$

C) $3\sqrt{29}$

D) $2\sqrt{30}$

9) For $f(x) = 4x^2 - 5x + 2$, find $f(k - 1)$.

A) $f(k - 1) = 4k^2 - 13k + 11$

B) $f(k - 1) = -13k^2 + 4k + 11$

C) $f(k - 1) = 4k^2 - 13k + 1$

D) $f(k - 1) = 4k^2 + 3k + 1$

10) For $f(x) = 3x^2 + 4x + 5$, find $f(k)$.

A) $f(k) = 3k^2 + 4k + 5$

B) $f(k) = 3k^2 + 4k + 25$

C) $f(k) = 9k^2 + 16k + 25$

D) $f(k) = 3k^2 + 16k + 5$

11) For $f(x) = x^2 - 5$, find $f(a - 4)$.

A) $a^2 - 8a + 11$

B) $a^2 + 16$

C) $a^2 - 8a + 16$

D) $a^2 - 9$

12) For $f(x) = 5x^2 - 4x + 7$, find $f(k - 1)$.

A) $f(k - 1) = 5k^2 - 14k + 16$

B) $f(k - 1) = -14k^2 + 5k + 16$

C) $f(k - 1) = 5k^2 - 14k + 8$

D) $f(k - 1) = 5k^2 + 31k + 8$

13) For $g(x) = \frac{1}{2}x + 3$, find $g(a - 1)$.

A) $\frac{a + 5}{2}$

B) $\frac{a - 5}{2}$

C) $\frac{1}{2}a + 3$

D) $\frac{1}{2}a - 2$

14) For $g(x) = 4x - 3$, find $g(a - 1)$.

A) $4a - 7$

B) $4a - 3$

C) $4a + 1$

D) $\frac{1}{4}a - 3$

15) For $f(x) = \sqrt{2x - 5}$, find $f(p)$.

A) $\sqrt{2p - 5}$

B) $\sqrt{px - 5}$

C) $\sqrt{2x - p}$

D) $2p - 5$

16) For $f(x) = \sqrt{6 - x}$, find $f(m + 2)$.

A) $\sqrt{4 - m}$

B) $\sqrt{8 - m}$

C) $\sqrt{m + 2 - x}$

D) $\sqrt{m + 2}$

2 Determine If Graph Is a Function

MULTIPLE CHOICE. Choose the one alternative that best completes the statement or answers the question.

Determine whether the graph is the graph of a function.

1)

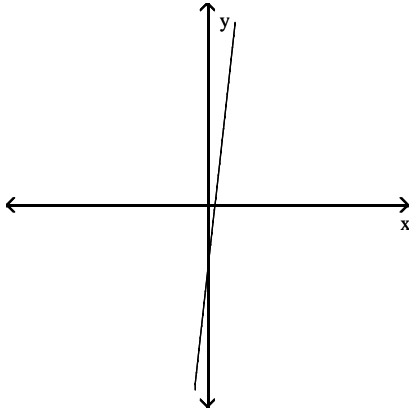

A) Function

B) Not a function

2)

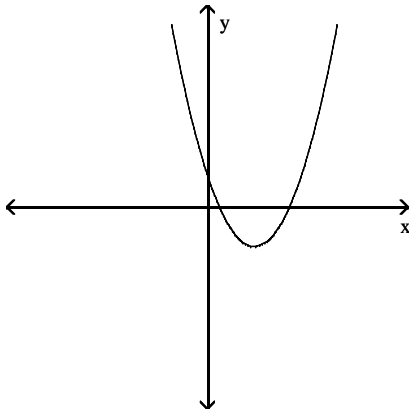

A) Function

B) Not a function

3)

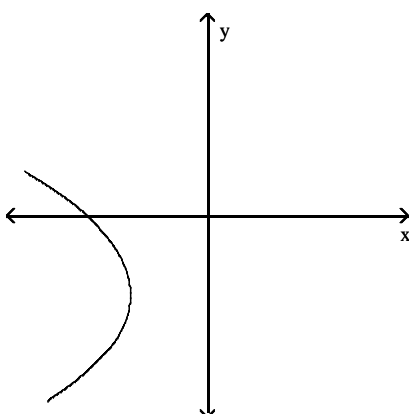

A) Not a function

B) Function

4)

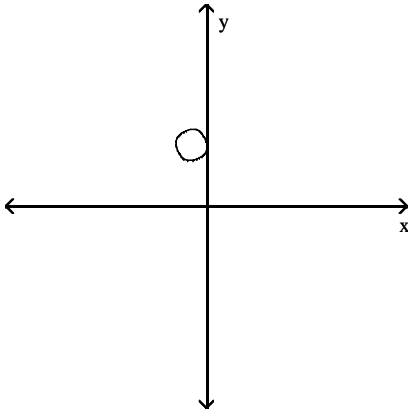

A) Not a function

B) Function

5)

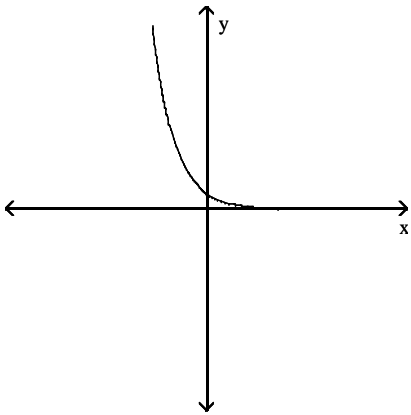

A) Function

B) Not a function

6)

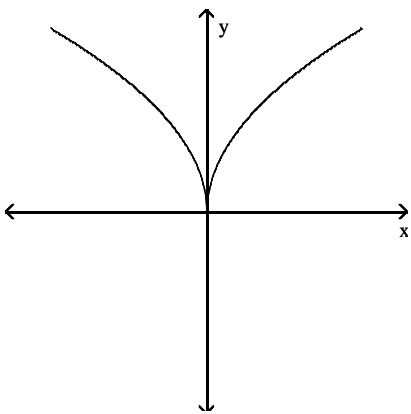

A) Function

B) Not a function

7)

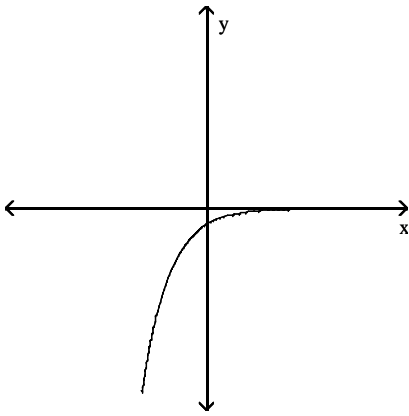

A) Function

B) Not a function

8)

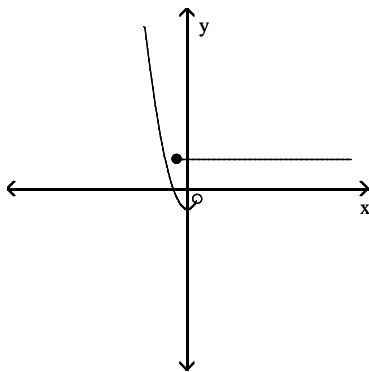

A) Not a function

B) Function

9)

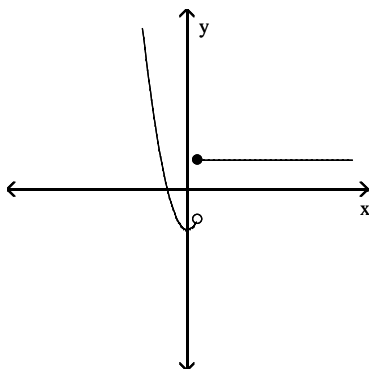

A) Function

B) Not a function

10)

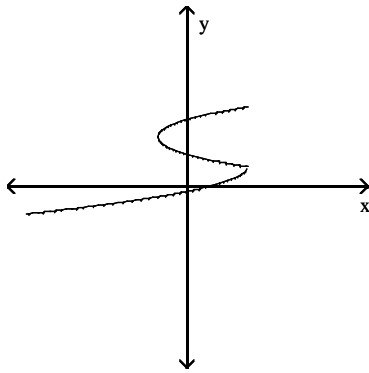

A) Not a function

B) Function

3 Find Difference Quotient

MULTIPLE CHOICE. Choose the one alternative that best completes the statement or answers the question.

For the given function, find and simplify $[f(x + h) - f(x)]/h$.

1) $f(x) = 9x - 8$

A) 9

B) $9 + \frac{-16}{h}$

C) $9 + \frac{18(x-8)}{h}$

D) 0

2) $f(x) = 5x^2$

A) $5(2x+h)$

B) $\frac{10}{h} + x + 5h$

C) $\frac{5(2x^2 + 2xh + h^2)}{h}$

D) 5

3) $f(x) = 8$

A) 0

B) 1

C) $1 + \frac{16}{h}$

D) 8

4) $f(x) = \frac{1}{5x}$

A) $\frac{-1}{5x(x+h)}$

B) $\frac{-1}{x(x+h)}$

C) $\frac{1}{5x}$

D) 0

5) $f(x) = x^2 + 6x - 6$

A) $2x + h + 6$

B) $\frac{2x^2 + 2x + 2xh + h^2 + h - 12}{h}$

C) $2x + h - 6$

D) 1

4 Find Domain of Function

MULTIPLE CHOICE. Choose the one alternative that best completes the statement or answers the question.

Find the natural domain of the function.

1) $f(x) = \frac{1}{x+9}$

A) $\{x: x \neq -9\}$

B) all real numbers

C) $\{x: x > 9\}$

D) $\{x: x \neq 9\}$

$$2) y = \frac{x}{x-7}$$

A) $\{x: x \neq 7\}$

B) all real numbers

C) $\{x: x > -7\}$

D) $\{x: x \neq -7\}$

$$3) f(x) = \frac{5}{9x-8}$$

A) $\left\{x: x \neq \frac{8}{9}\right\}$

B) $\left\{x: x \neq \frac{9}{8}\right\}$

C) $\left\{x: x > \frac{8}{9}\right\}$

D) all real numbers

$$4) y = \sqrt{4-x}$$

A) $\{x: x \leq 4\}$

B) all real numbers

C) $\{x: x \geq 4\}$

D) $\{x: x < 4\}$

$$5) f(x) = \sqrt{x+5}$$

A) $\{x: x \geq -5\}$

B) $\{x: x > 5\}$

C) $\{x: x \geq 5\}$

D) $\{x: x \neq -5\}$

$$6) f(x) = \sqrt{-x-4}$$

A) $\{x: x \leq -4\}$

B) $\{x: x \geq -4\}$

C) $\{x: x \geq 4\}$

D) $\{x: x \leq 4\}$

$$7) f(x) = \frac{x-9}{\sqrt{x+9}}$$

A) $\{x: x > -9\}$

B) $\{x: x > 9\}$

C) $\{x: x \geq -9\}$

D) $\{x: \neq -9\}$

$$8) f(x) = \sqrt{9-x^2}$$

A) $\{x: |x| \leq 3\}$

B) $\{x: |x| < 3\}$

C) all real numbers

D) $\{x: x \geq 0\}$

$$9) f(x) = (6x+7)^{1/3}$$

A) all real numbers

B) $\left\{x: x \geq \frac{6}{7}\right\}$

C) $\left\{x: x \geq -\frac{6}{7}\right\}$

D) $\left\{x: x \leq \frac{6}{7}\right\}$

$$10) f(x) = \sqrt{7(x+8)^{-1}}$$

A) $\{x: x > -8\}$

B) $\{x: x \neq 8\}$

C) all real numbers

D) $\{x: x \geq 8\}$

$$11) f(x) = \sqrt{2(x-7)^{-1}}$$

A) $\{x: x > 7\}$

B) all real numbers

C) $\{x: x \neq -7\}$

D) $\{x: x \leq 7\}$

5 Determine If Function Is Even, Odd, or Neither

MULTIPLE CHOICE. Choose the one alternative that best completes the statement or answers the question.

Determine if the function is even, odd, or neither.

1) $f(x) = 7$

A) Even

B) Odd

C) Neither

2) $f(x) = 5x^2 + 2$

A) Even

B) Odd

C) Neither

3) $f(x) = -5x^4 + 4x + 7$

A) Even

B) Odd

C) Neither

4) $f(x) = 5x^5 + 3x^3$

A) Even

B) Odd

C) Neither

5) $f(x) = (x + 2)(x + 8)$

A) Even

B) Odd

C) Neither

6) $f(x) = \frac{2}{x^2 + 5}$

A) Even

B) Odd

C) Neither

7) $f(x) = \frac{-6}{x + 4}$

A) Even

B) Odd

C) Neither

8) $g(x) = \frac{9x}{x^2 + 4}$

A) Even

B) Odd

C) Neither

9) $g(x) = |7x^5|$

A) Even

B) Odd

C) Neither

10) $h(t) = \sqrt{t^2 + 3}$

A) Even

B) Odd

C) Neither

6 Solve Apps: Functions

MULTIPLE CHOICE. Choose the one alternative that best completes the statement or answers the question.

Solve the problem.

- 1) A box with an open top is to be constructed from a rectangular piece of cardboard with dimensions 12 inches by 24 inches by cutting out equal squares of side x at each corner and then folding up the sides as in the figure. Express the volume V of the box as a function of x .

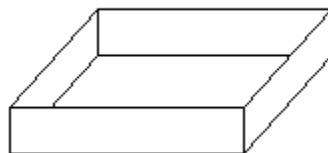
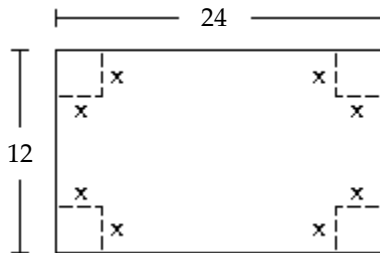

A) $V(x) = x(12 - 2x)(24 - 2x)$

B) $V(x) = (12 - 2x)(24 - 2x)$

C) $V(x) = x(12 - x)(24 - x)$

D) $V(x) = (12 - x)(24 - x)$

- 2) The figure shown here shows a rectangle inscribed in an isosceles right triangle whose hypotenuse is 10 units long. Express the area A of the rectangle in terms of x .

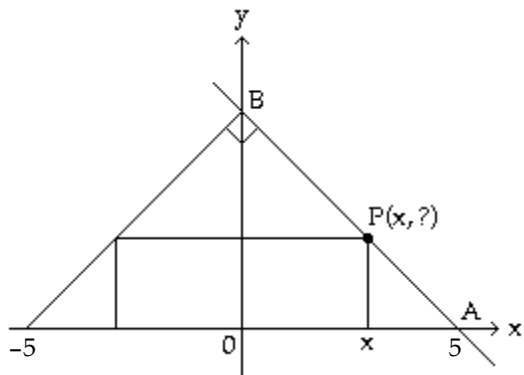

- A) $A(x) = 2x(5 - x)$ B) $A(x) = x(5 - x)$ C) $A(x) = 2x(x - 5)$ D) $A(x) = 2x^2$

- 3) A cone is constructed from a circular piece of paper with a 5-inch radius by cutting out a sector of the circle with arc length x . The two edges of the remaining portion are joined together to form a cone with radius r and height h , as shown in the figure. Express the volume V of the cone as a function of x .

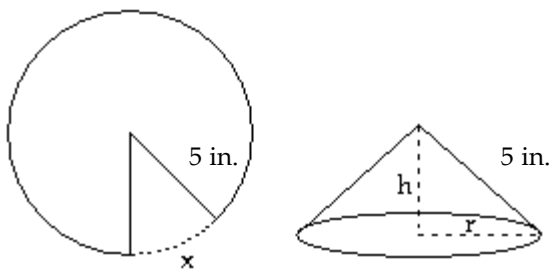

- A) $V(x) = \frac{(10\pi - x)^2 \sqrt{20\pi x - x^2}}{24\pi^2}$ B) $V(x) = \frac{(10\pi - x)^2 (20\pi x - x^2)}{4\pi^2}$
 C) $V(x) = \frac{(10\pi - x)^2 \sqrt{20\pi x - x^2}}{4\pi^2}$ D) $V(x) = \frac{(10\pi - x)(20\pi x - x^2)}{24\pi^2}$

- 4) A power plant is located on a river that is 700 feet wide. To lay a new cable from the plant to a location in a city 1 mile downstream on the opposite side costs \$175 per foot across the river and \$150 per foot along the land. Suppose that the cable goes from the plant to a point Q on the opposite side that is x feet from the point P directly opposite the plant. Write a function $C(x)$ that gives the cost of laying the cable in terms of the distance x .

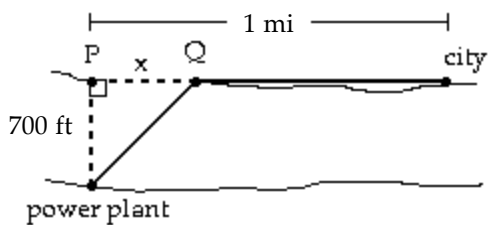

- A) $C(x) = 175\sqrt{x^2 + 700^2} + 150(5280 - x)$ B) $C(x) = 175\sqrt{x^2 + 700^2} + 150(1 - x)$
 C) $C(x) = 150\sqrt{x^2 + 700^2} + 175(5280 - x)$ D) $C(x) = 175(700 - x) + 150(1 - x)$

- 5) From a 38-inch by 38-inch piece of metal, squares are cut out of the four corners so that the sides can then be folded up to make a box. Let x represent the length of the sides of the squares, in inches, that are cut out. Express the volume of the box as a function of x . Give the function and state its domain.
- A) $V = 4x^3 - 152x^2 + 1444x$: $0 < x < 19$ B) $V = 2x^3 - 114x^2 + 1444x$: $x > 0$
 C) $V = 4x^3 - 152x^2 + 1444x$: $x < 38$ D) $V = 2x^3 - 114x^2 + 38x$: $0 < x < 19$
- 6) A rectangular box with volume 234 cubic feet is built with a square base and top. The cost is \$1.50 per square foot for the top and the bottom and \$2.00 per square foot for the sides. Let x represent the length of a side of the base. Express the cost the box as a function of x . Give the function and state its domain.
- A) $C = 3x^2 + \frac{1872}{x}$: $x > 0$ B) $C = 3x^2 + \frac{936}{x}$: $x > 4$
 C) $C = 2x^2 + \frac{1872}{x}$: $x < 10$ D) $C = 4x + \frac{1872}{x^2}$: $x > 0$
- 7) A rectangle that is x feet wide is inscribed in a circle of radius 38 feet. Express the area of the rectangle as a function of x . Give the function and state its domain.
- A) $A = x\sqrt{5776 - x^2}$: $0 < x < 76$ B) $A = x^2\sqrt{2888 - x^2}$: $x > 0$
 C) $A = x(5776 - x^2)$: $0 < x < 76$ D) $A = x\sqrt{4332 - x}$: $x < 76$
- 8) A sphere has a radius of 10 in. If the radius is decreased by x in., express the volume of the sphere as a function of x . What is the domain of $V = f(x)$?
- A) $V = \frac{4}{3}\pi(10 - x)^3$: $0 \leq x < 10$ B) $V = \frac{4}{3}\pi(x - 10)^3$: $0 \leq x \leq 10$
 C) $V = \frac{4}{3}\pi(10 - x)^3$: $x \geq 10$ D) $V = \frac{4}{3}\pi(10 - x)^3$: $0 < x < 10$
- 9) A glass-cage elevator rises on the outside of a hotel which is h m tall. A person stands 100 m from the base of the elevator. Express the distance d from the person to the elevator as a function of the height x of the elevator. What is the range of $d = f(x)$?
- A) $d = \sqrt{100^2 + x^2}$: $100 \leq d \leq \sqrt{100^2 + h^2}$ B) $d = \sqrt{100^2 - x^2}$: $100 \leq d \leq \sqrt{100^2 - h^2}$
 C) $d = 100^2 + x^2$: $0 \leq d \leq 100$ D) $d = \sqrt{100^2 + x^2}$: $d \leq 100$
- 10) A window is in the shape of a square topped by a semicircle. The side of the square is x cm and the window cannot be wider than 140 cm. Find the function for the area of the window and the domain of the function.
- A) $A = x^2 + \frac{1}{2}\pi\left(\frac{x}{2}\right)^2$: $0 < x \leq 140$ B) $A = x^2 + \frac{1}{2}\pi x^2$: $0 < x \leq 140$
 C) $A = 4x^2 + \frac{1}{2}\pi x^2$: $0 < x \leq 140$ D) $A = x^2 + \frac{1}{2}\pi\left(\frac{x}{2}\right)^2$: $0 < x \leq 140^2 + \frac{1}{2}\pi\left(\frac{140}{2}\right)^2$
- 11) A window is in the shape of a square topped by a semicircle. The side of the square is x cm and the window cannot be wider than 150 cm. Find the function for the perimeter of the window and the domain of the function.
- A) $P = 3x + \frac{1}{2}\pi x$: $0 < x \leq 150$ B) $P = 4x + \pi x$: $0 < x \leq 150$
 C) $P = 3x + \frac{1}{2}\pi x^2$: $0 < 150 \leq x$ D) $P = 4x + \frac{1}{2}\pi x^2$: $0 < x \leq 150$

7 Tech: Graph Function

MULTIPLE CHOICE. Choose the one alternative that best completes the statement or answers the question.

Use your graphing calculator to find the graph of the function.

1) $f(x) = x^4 + x^3 - 5x^2 - 4x + 4$

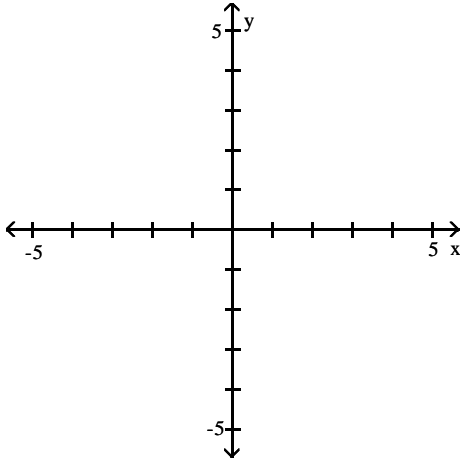

A)

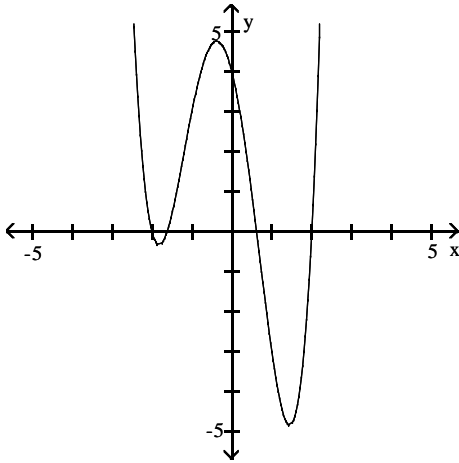

B)

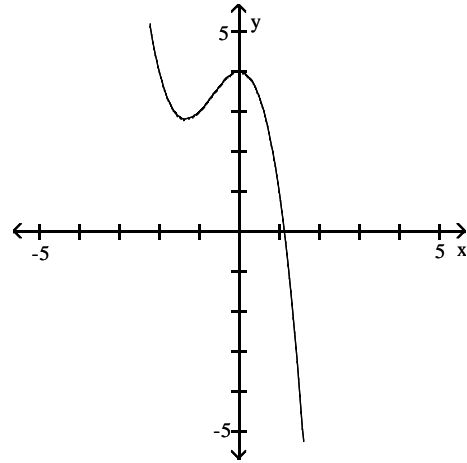

C)

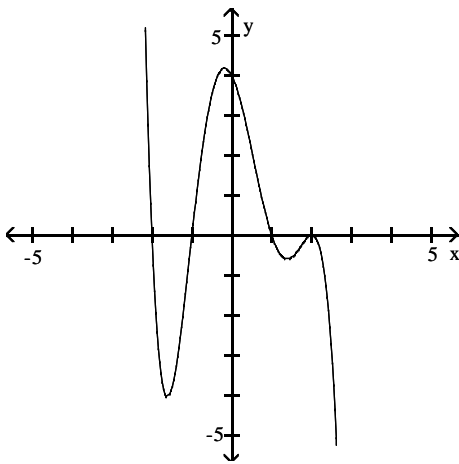

D)

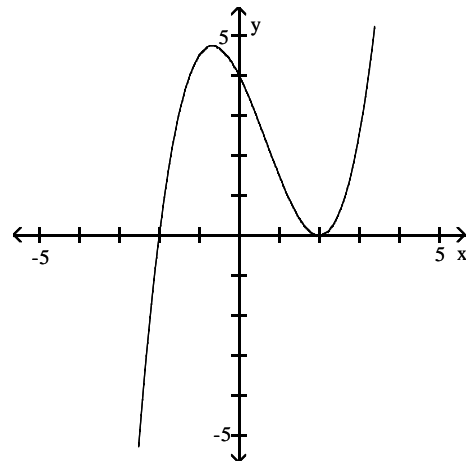

$$2) f(x) = \frac{3}{x+3}$$

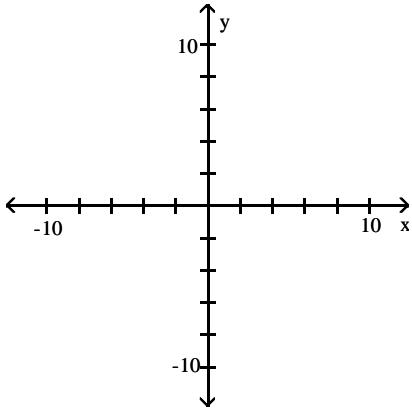

A)

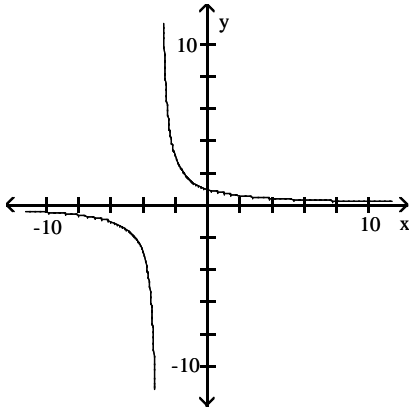

B)

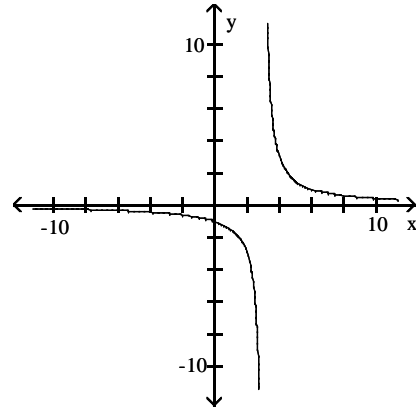

C)

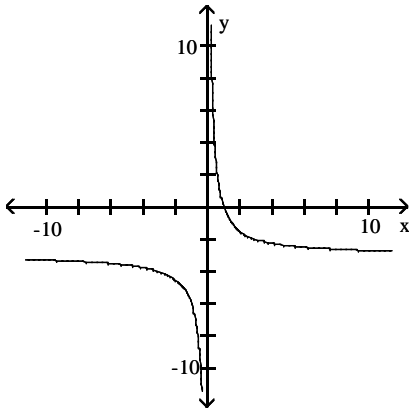

D)

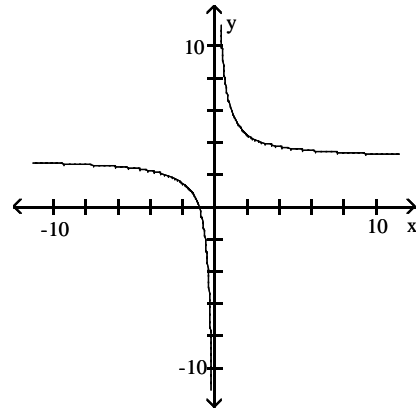

$$3) f(x) = \frac{2}{x-4}$$

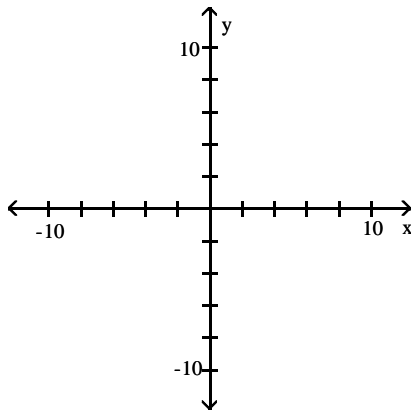

A)

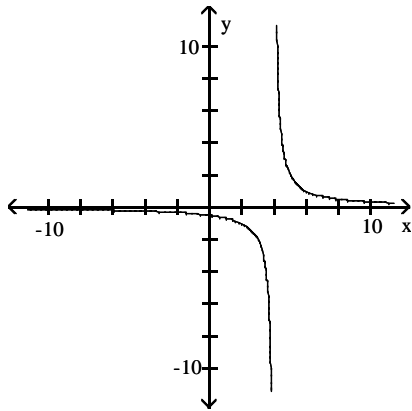

B)

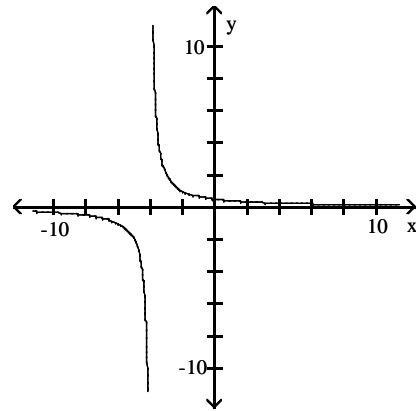

C)

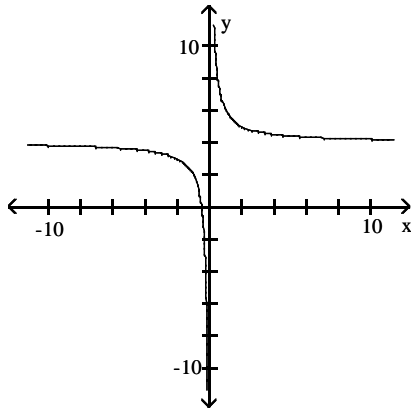

D)

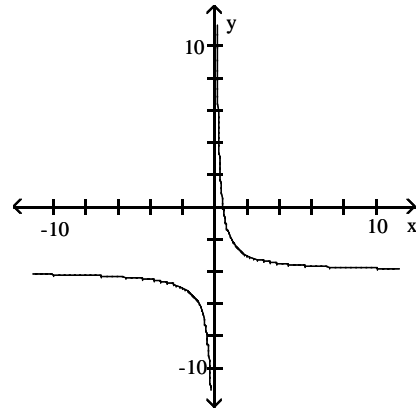

$$4) f(x) = \frac{1}{(x+1)^2}$$

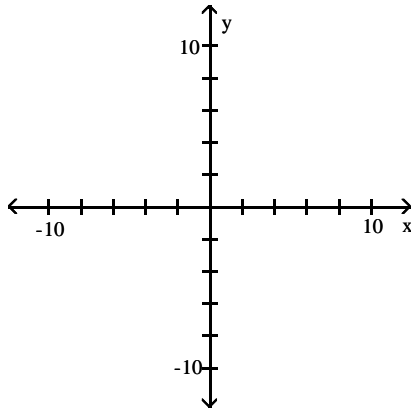

A)

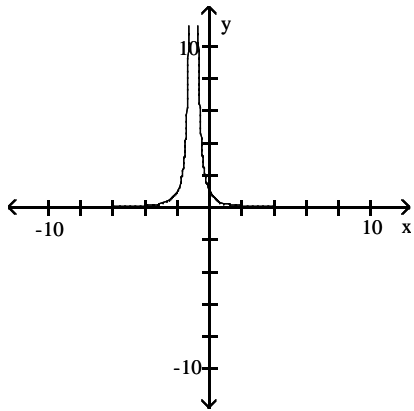

B)

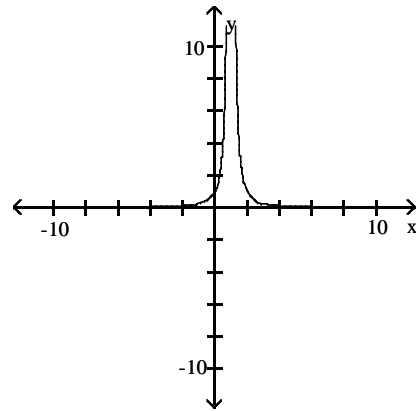

C)

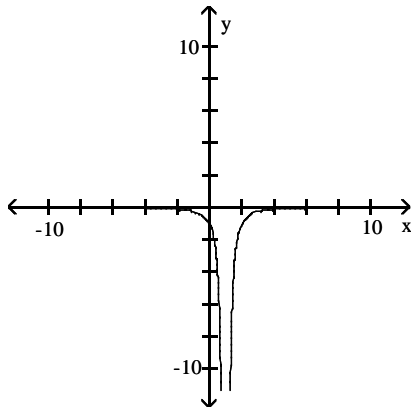

D)

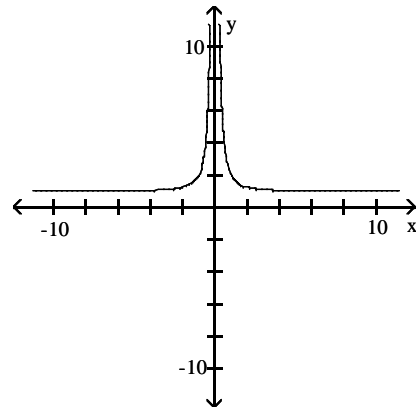

5) $f(x) = \frac{10}{x^2}$

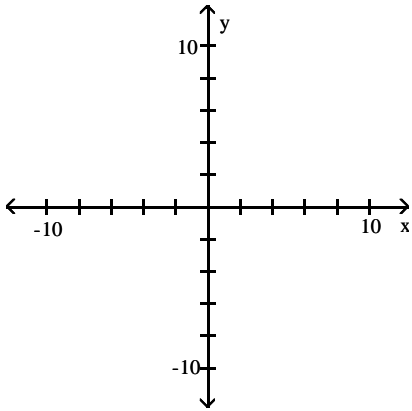

A)

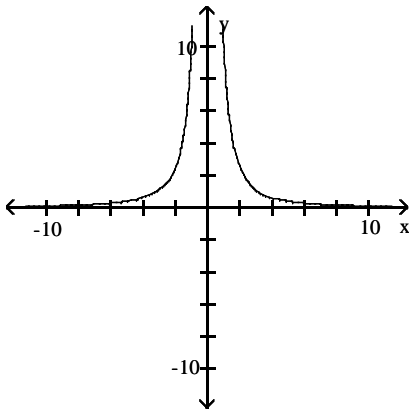

B)

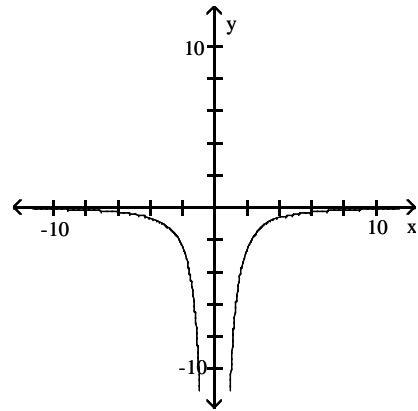

C)

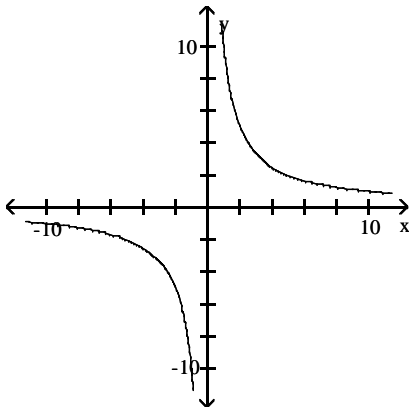

D)

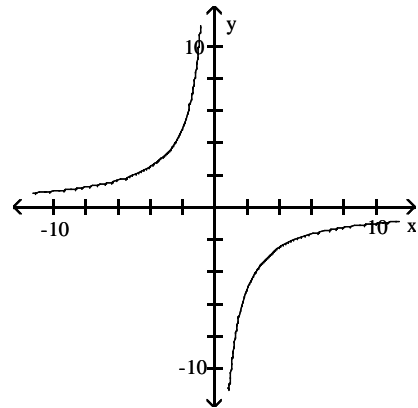

6) $f(x) = \sin 4x + \cos 2x$

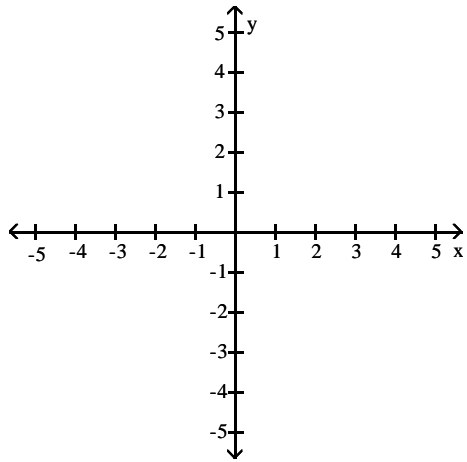

A)

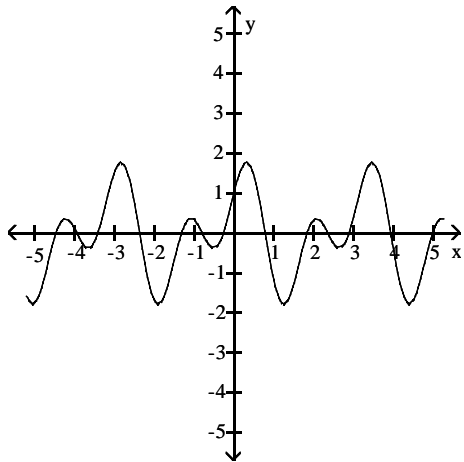

B)

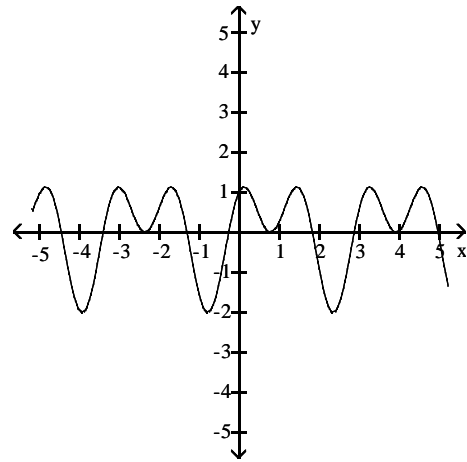

C)

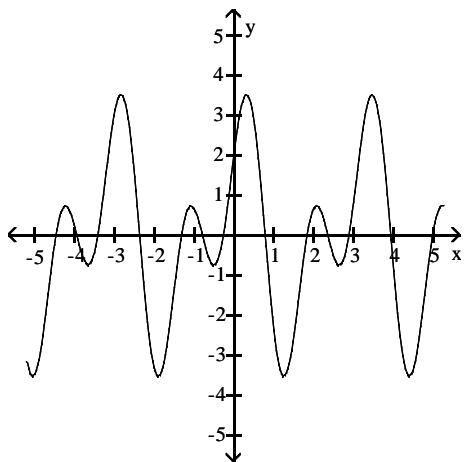

D)

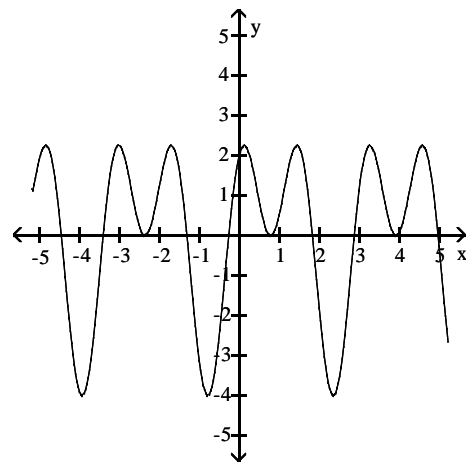

7) $f(x) = 2 \cos^3 x$

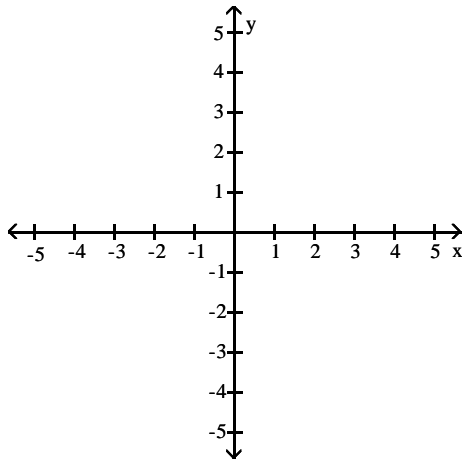

A)

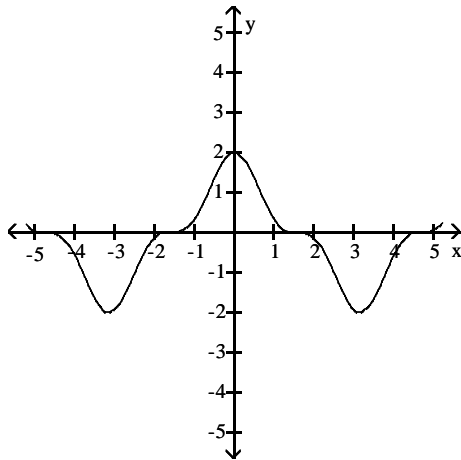

B)

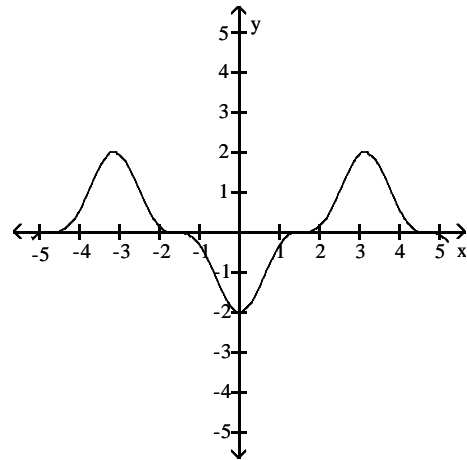

C)

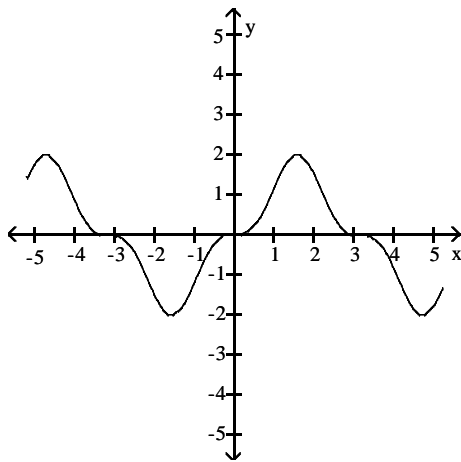

D)

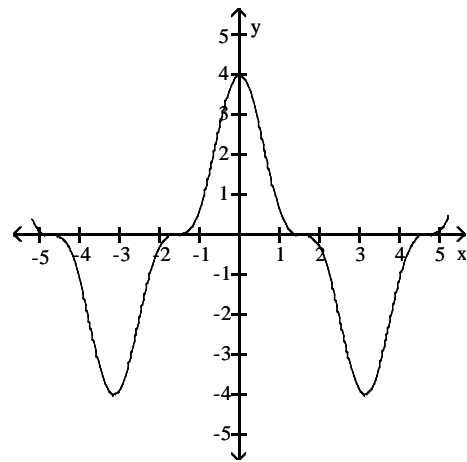

8 Tech: Identify x-Intercepts

MULTIPLE CHOICE. Choose the one alternative that best completes the statement or answers the question.

Use your graphing calculator to find the x-intercepts of the function to the nearest tenth.

1) $f(x) = 2x^2 + 8x + 7$

A) -1.3, -2.7

B) -0.6, -1.4

C) -3.3, -4.7

D) 0.7, -4.7

- 2) $f(x) = 2x^2 - 4x - 23$; x between 4 and 5
 A) 4.5 B) 4.3 C) 4.6 D) 4.4
- 3) $f(x) = 3x^3 + x^2 - 21x - 7$
 A) -0.3, 2.6, -2.6 B) -3, 2.7, -2.7 C) 0.3, 2.6, -2.6 D) 3, 7, -7
- 4) $f(x) = x^4 - 8x^2 + 15$
 A) 2.2, -2.2, 1.7, -1.7 B) 5, -5, 3, -3 C) -1, 2.5, 2.5, -2.5 D) 2.2, 1.7

9 Tech: Find Range

MULTIPLE CHOICE. Choose the one alternative that best completes the statement or answers the question.

Use your graphing calculator to find the range of the function.

- 1) $f(x) = x^3 + 2$
 A) $(-\infty, \infty)$ B) $(-\infty, 2) \cup (2, \infty)$ C) $(2, \infty)$ D) $(-\infty, 2)$
- 2) $f(x) = x^4 + 3x^2 - 4$
 A) $[-4, \infty)$ B) $(-\infty, -4]$ C) $(-4, \infty)$ D) $(-\infty, -4)$
- 3) $f(x) = \frac{4}{x - 6}$
 A) $(-\infty, 0) \cup (0, \infty)$ B) $(-\infty, 6) \cup (6, \infty)$ C) $(-\infty, 4) \cup (4, \infty)$ D) $(0, \infty)$

10 Tech: Find Values Satisfying Statement

MULTIPLE CHOICE. Choose the one alternative that best completes the statement or answers the question.

Provide an appropriate response.

- 1) Graph the functions $f(x) = \frac{x}{3}$ and $g(x) = 3 + \frac{10}{3x}$ together to identify the values of x for which $f(x) > g(x)$.
 A) $(-1, 0) \cup (10, \infty)$ B) $(-\infty, -1) \cup (0, 10)$ C) $(-1, 10)$ D) $(10, \infty)$
- 2) Graph the functions $f(x) = \frac{4}{x - 1}$ and $g(x) = \frac{2}{x + 1}$ together to identify the values of x for which $f(x) < g(x)$.
 A) $(-\infty, -3)$ B) $(-3, \infty)$ C) $(-3, -1) \cup (1, \infty)$ D) $(-1, 1) \cup (1, \infty)$

0.6 Operations on Functions

1 Find Sum, Difference, Product, or Quotient of Functions

MULTIPLE CHOICE. Choose the one alternative that best completes the statement or answers the question.

For the given functions f and g , find the requested function or functional value.

- 1) $f(x) = 7x - 8$, $g(x) = 2x - 9$
 Find $f - g$.
 A) $5x + 1$ B) $5x - 17$ C) $9x - 17$ D) $-5x - 1$

2) $f(x) = 8x^2 - 5x$, $g(x) = x^2 - 2x - 15$

Find $\frac{f}{g}$.

A) $\frac{8x^2 - 5x}{x^2 - 2x - 15}$

B) $\frac{8x}{x + 1}$

C) $\frac{8x - 5}{-2}$

D) $\frac{8 - x}{15}$

3) $f(x) = 9 - 2x$, $g(x) = -5x + 2$

Find $f + g$.

A) $-7x + 11$

B) $-5x + 9$

C) $4x$

D) $3x + 11$

4) $f(x) = \sqrt{2x + 3}$, $g(x) = \sqrt{16x - 25}$

Find fg .

A) $(\sqrt{2x + 3})(\sqrt{16x - 25})$

B) $(4x - 5)(\sqrt{2x + 3})$

C) $(2x + 3)(16x - 25)$

D) $(2x + 3)(4x - 5)$

5) $f(x) = x^2 + \frac{1}{4}x + 4$; $g(x) = x^3 + \frac{1}{2}x^2 + x$

Find $(f + g)(x)$.

A) $x^3 + \frac{3}{2}x^2 + \frac{5}{4}x + 4$

B) $2x^3 + \frac{3}{4}x^2 + 5x$

C) $2x^3 + \frac{3}{8}x^2 + 5x$

D) $x^3 + \frac{3}{4}x^2 + \frac{5}{8}x + 4$

6) $f(x) = x + 7$; $g(x) = x - 4$

Find $(f + g)(-2)$.

A) -1

B) -15

C) 7

D) -7

7) $f(x) = 4x - 2$; $g(x) = -3x + 1$

Find $(f + g)(3)$.

A) 2

B) 1

C) 18

D) 11

8) $f(x) = -4x^2 + 3x + 7$; $g(x) = -6x + 8$

Find $(f + g)(-4)$.

A) -37

B) -197

C) -157

D) 91

9) $f(x) = 2x - 4$; $g(x) = 2x^2 - 5$

Find $(f + g)(4)$.

A) 31

B) 41

C) 27

D) 35

10) $f(x) = 3x - 3$; $g(x) = 2x^2 + 2x - 3$

Find $(f + g)(2)$.

A) 12

B) 14

C) 6

D) 4

11) $f(x) = 3x^2 - 1$; $g(x) = 2x^2 - 4$

Find $(f + g)(5)$.

A) 147

B) 155

C) 107

D) 55

12) $f(x) = 3x^2 - 4$; $g(x) = 2x^2 + 3x - 4$

Find $(f + g)(3)$.

- A) 46 B) 54 C) 34 D) 28

13) $f(x) = -2x^2 + 6x + 5$; $g(x) = -5x + 7$

Find $(f + g)(4)$.

- A) -16 B) -55 C) -76 D) 48

14) $f(x) = -2x^2 - 6$; $g(x) = x - 6$

Find $(f - g)(4)$.

- A) -36 B) 34 C) -48 D) -28

15) $f(x) = 4x^2 - 7$; $g(x) = x - 7$

Find $(f - g)(3)$.

- A) 33 B) -32 C) 19 D) 39

16) $g(x) = 5x + 3$; $f(x) = 3x^2 + 3x + 5$

Find $\left(\frac{f}{g}\right)(-2)$.

- A) $-\frac{11}{7}$ B) $\frac{7}{11}$ C) $-\frac{13}{11}$ D) -7

17) $g(x) = 5x - 7$; $f(x) = 4x^2 + 14x + 2$

Find $\left(\frac{f}{g}\right)(-4)$.

- A) $-\frac{10}{27}$ B) $\frac{4}{10}$ C) $-\frac{4}{13}$ D) 5

2 Find Composition of Functions

MULTIPLE CHOICE. Choose the one alternative that best completes the statement or answers the question.

For the given functions, find the requested function or functional value.

1) For $f(x) = 3x + 6$ and $g(x) = 5x - 1$, find $(f \circ g)(x)$.

- A) $15x + 3$ B) $15x + 9$ C) $15x + 5$ D) $15x + 29$

2) For $f(x) = -3x + 6$ and $g(x) = 2x + 7$, find $(g \circ f)(x)$.

- A) $-6x + 19$ B) $-6x + 27$ C) $6x + 19$ D) $-6x - 5$

3) For $f(x) = \frac{5}{x-6}$ and $g(x) = \frac{7}{5x}$, find $(f \circ g)(x)$.

- A) $\frac{25x}{7-30x}$ B) $\frac{7x-42}{25x}$ C) $\frac{25x}{7+30x}$ D) $\frac{5x}{7-30x}$

4) For $f(x) = \frac{x-4}{7}$ and $g(x) = 7x + 4$, find $(g \circ f)(x)$.

A) x

B) $7x + 24$

C) $x + 8$

D) $x - \frac{4}{7}$

5) For $f(x) = \frac{1}{x}$ and $g(x) = 6x^3$, find $(g \circ f)(x)$.

A) $\frac{6}{x^3}$

B) $\frac{1}{6x^3}$

C) $\frac{1}{x^3}$

D) $\frac{6}{x}$

6) For $f(x) = 4x^2 + 3x + 5$ and $g(x) = 3x - 4$, find $(g \circ f)(x)$.

A) $12x^2 + 9x + 11$

B) $12x^2 + 9x + 19$

C) $4x^2 + 9x + 11$

D) $4x^2 + 3x + 1$

7) For $f(x) = \sqrt{x+9}$ and $g(x) = 8x - 13$, find $(f \circ g)(x)$.

A) $2\sqrt{2x-1}$

B) $2\sqrt{2x+1}$

C) $8\sqrt{x+9} - 13$

D) $8\sqrt{x-4}$

8) For $f(x) = \sqrt{x+8}$ and $g(x) = x - 5$, find $(g \circ g)(x)$.

A) $x - 10$

B) x

C) $x + 3$

D) $(x - 5)^2$

9) For $f(x) = \sqrt{x}$, $g(x) = \frac{x}{5}$, and $h(x) = 5x + 20$, find $(f \circ g \circ h)(x)$.

A) $\sqrt{x+4}$

B) $\sqrt{x+20}$

C) $\sqrt{x} + 4$

D) $5\sqrt{x} + 20$

10) For $f(x) = \sqrt{x}$, $g(x) = \frac{x}{2}$, and $h(x) = 2x + 4$, find $(h \circ g \circ f)(x)$.

A) $\sqrt{x} + 4$

B) $\sqrt{x+2}$

C) $\sqrt{x} + 2$

D) $2\sqrt{x} + 4$

11) For $f(x) = 5x + 7$ and $g(x) = 9x^2 - 3x + 6$, find $(g \circ f)(2)$.

A) 2556

B) 187

C) 108

D) 97

12) For $f(x) = -3x - 1$ and $g(x) = 5x^2 + 5x - 7$, find $(g \circ f)(-7)$.

A) 2093

B) -610

C) 193

D) 230

13) For $f(x) = 2x^3$ and $g(x) = -x^2 + 4$, find $(g \circ g)(3)$.

A) -21

B) -250

C) -5

D) -10

14) For $f(x) = \sqrt{x+4}$ and $g(x) = 5x$, find $(f \circ g)(2)$.

A) $\sqrt{14}$

B) $5\sqrt{6}$

C) $\sqrt{30}$

D) $5\sqrt{30}$

15) For $f(x) = \frac{12}{x+3}$ and $g(x) = |x-5|$, find $(g \circ f)(1)$.

A) 2

B) 12

C) $\frac{12}{7}$

D) 7

3 Express Function as a Composition of Functions

MULTIPLE CHOICE. Choose the one alternative that best completes the statement or answers the question.

Find functions f and g so that $h(x) = (f \circ g)(x)$.

1) $h(x) = \frac{1}{x^2 - 8}$

A) $f(x) = 1/x, g(x) = x^2 - 8$

B) $f(x) = 1/8, g(x) = x^2 - 8$

C) $f(x) = 1/x^2, g(x) = -1/8$

D) $f(x) = 1/x^2, g(x) = x - 8$

2) $h(x) = |6x + 1|$

A) $f(x) = |x|, g(x) = 6x + 1$

B) $f(x) = -|x|, g(x) = 6x + 1$

C) $f(x) = |-x|, g(x) = 6x - 1$

D) $f(x) = x, g(x) = 6x + 1$

3) $h(x) = \frac{4}{x^2} + 2$

A) $f(x) = x + 2, g(x) = 4/x^2$

B) $f(x) = 4/x^2, g(x) = 2$

C) $f(x) = 1/x, g(x) = 4/x + 2$

D) $f(x) = x, g(x) = 4/x + 2$

4) $h(x) = \frac{9}{\sqrt{3x + 5}}$

A) $f(x) = 9/\sqrt{x}, g(x) = 3x + 5$

B) $f(x) = 9/x, g(x) = 3x + 5$

C) $f(x) = \sqrt{3x + 5}, g(x) = 9$

D) $f(x) = 9, g(x) = \sqrt{3 + 5}$

5) $h(x) = (-5x + 14)^7$

A) $f(x) = x^7, g(x) = -5x + 14$

B) $f(x) = -5x + 14, g(x) = x^7$

C) $f(x) = (-5x)^7, g(x) = 14$

D) $f(x) = -5x^7, g(x) = x + 14$

6) $h(x) = \sqrt{65x^2 + 22}$

A) $f(x) = \sqrt{x}, g(x) = 65x^2 + 22$

B) $f(x) = 65x^2 + 22, g(x) = \sqrt{x}$

C) $f(x) = \sqrt{65x + 22}, g(x) = x^2$

D) $f(x) = \sqrt{65x^2}, g(x) = \sqrt{22}$

4 Graph Function Using Translations

MULTIPLE CHOICE. Choose the one alternative that best completes the statement or answers the question.

Sketch the requested graphs.

- 1) Begin by graphing the standard quadratic function $f(x) = x^2$ as a solid curve. Then use transformations of this graph to graph the function $g(x) = x^2 - 2$ as a dashed curve.

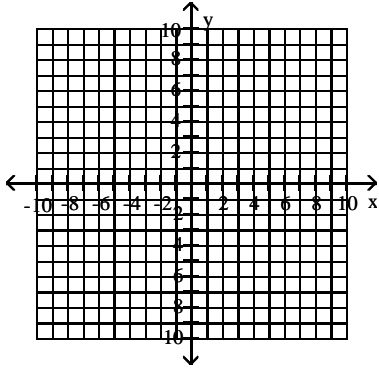

A)

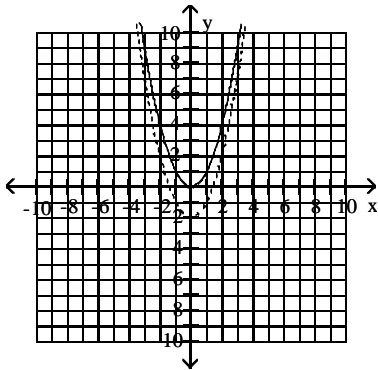

B)

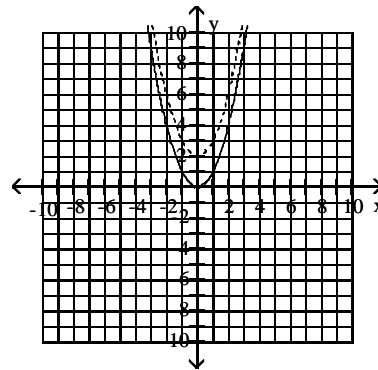

C)

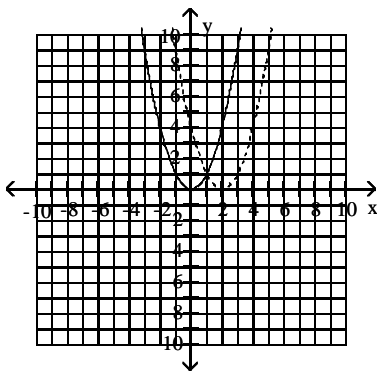

D)

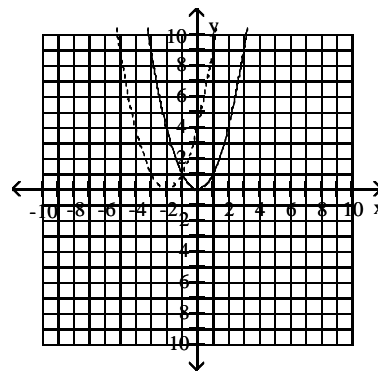

2) Begin by graphing the standard square root function $f(x) = \sqrt{x}$ as a solid curve. Then use transformations of this graph to graph the function $g(x) = \sqrt{x} - 2$ as a dashed curve.

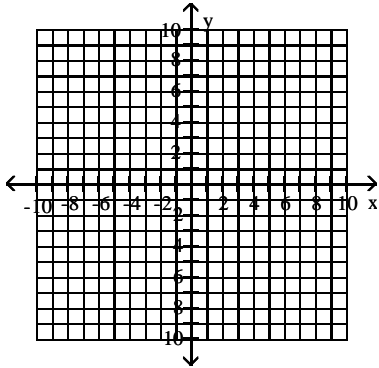

A)

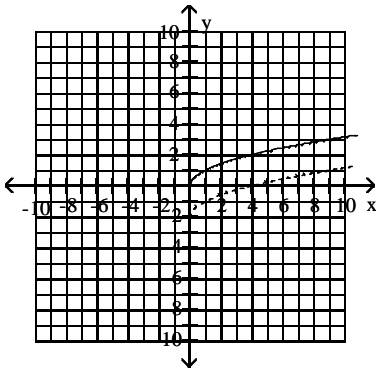

B)

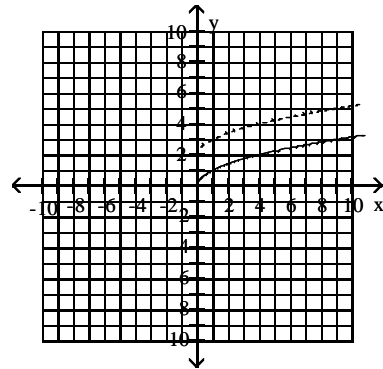

C)

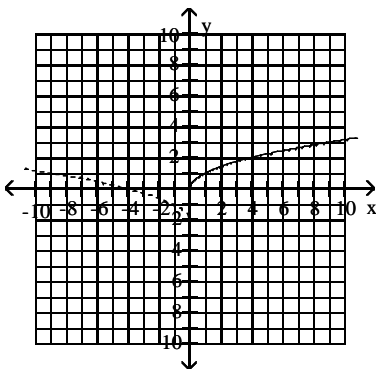

D)

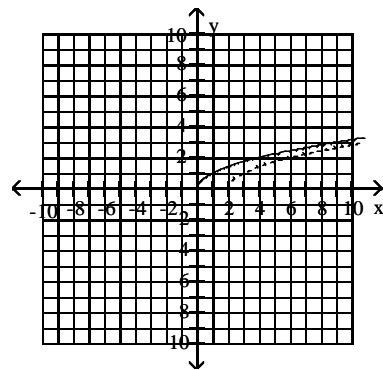

3) Begin by graphing the standard absolute value function $f(x) = |x|$ as a solid curve. Then use transformations of this graph to graph the function $g(x) = |x| + 2$ as a dashed curve.

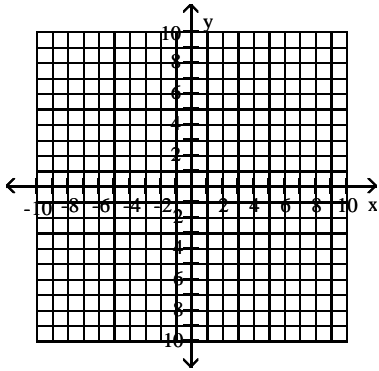

A)

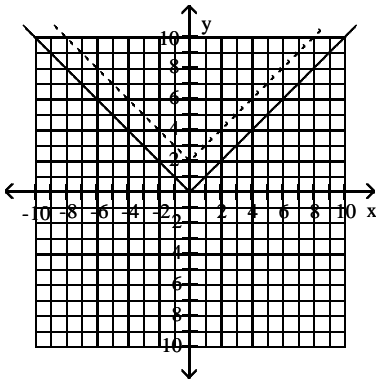

B)

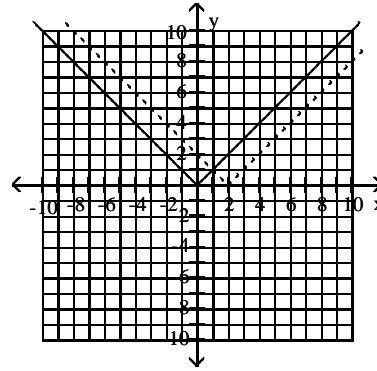

C)

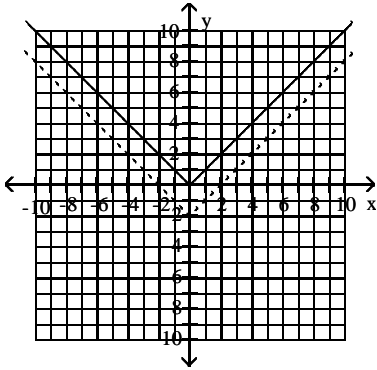

D)

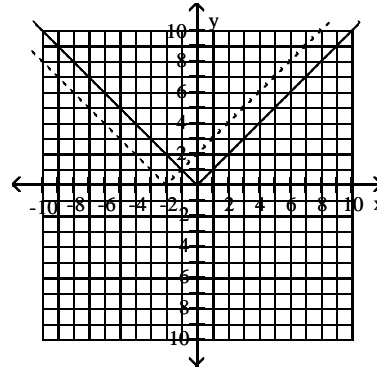

- 4) Begin by graphing the standard cubic function $f(x) = x^3$ as a solid curve. Then use transformations of this graph to graph the function $g(x) = x^3 + 3$ as a dashed curve.

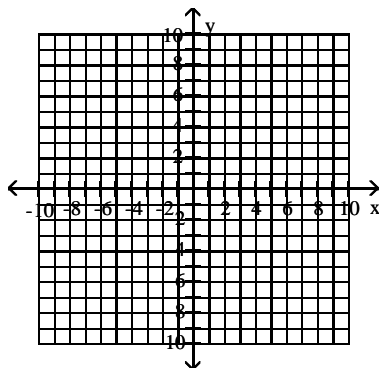

A)

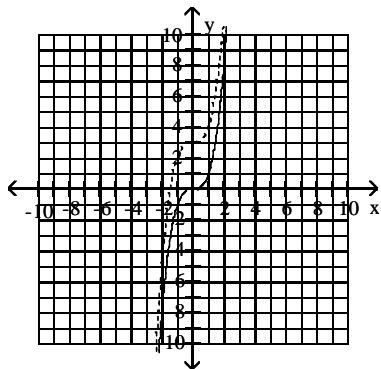

B)

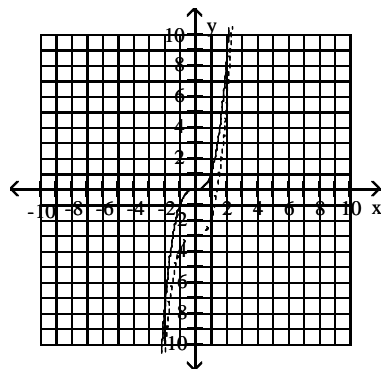

C)

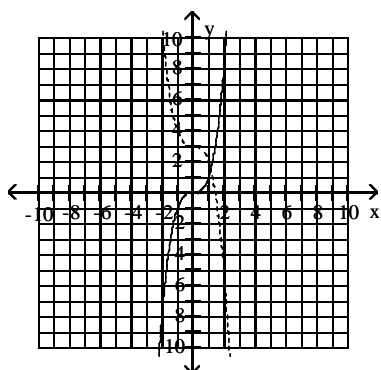

D)

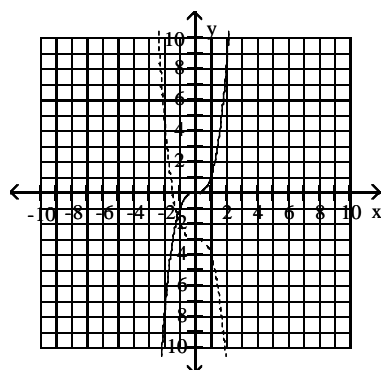

5) Begin by graphing the standard quadratic function $f(x) = x^2$ as a solid curve. Then use transformations of this graph to graph the function $g(x) = (x + 2)^2$ as a dashed curve.

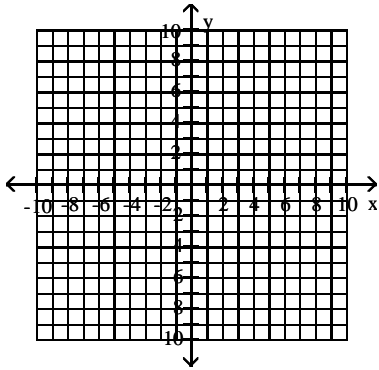

A)

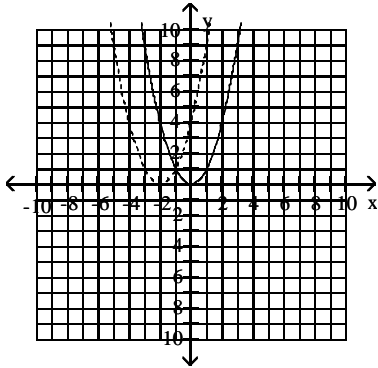

B)

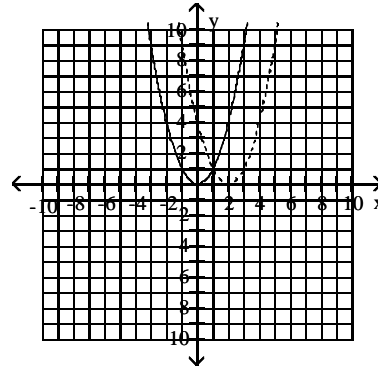

C)

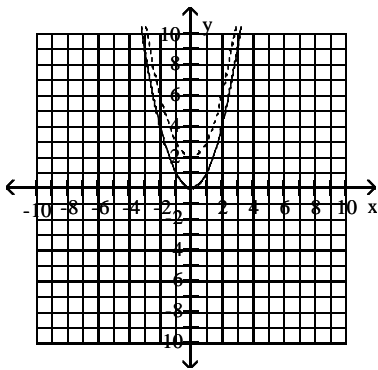

D)

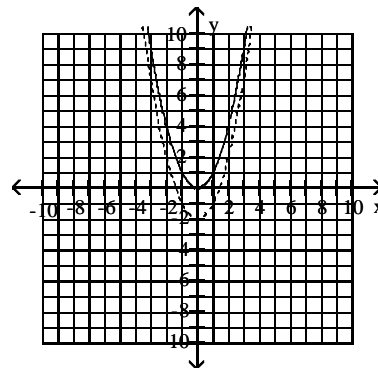

- 6) Begin by graphing the standard square root function $f(x) = \sqrt{x}$ as a solid curve. Then use transformations of this graph to graph the function $g(x) = \sqrt{x+1}$ as a dashed curve.

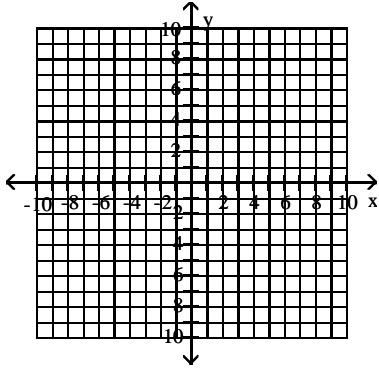

A)

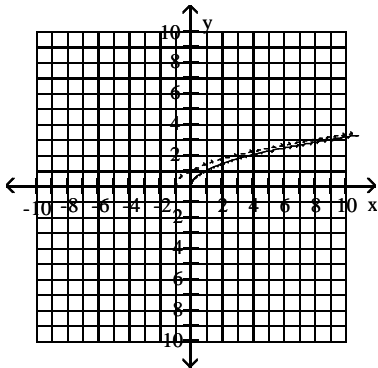

B)

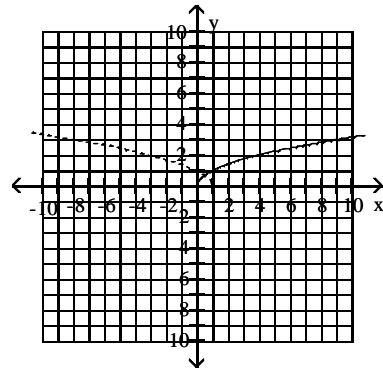

C)

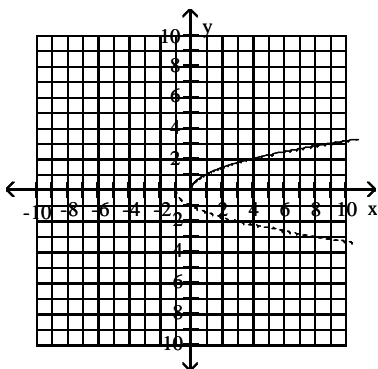

D)

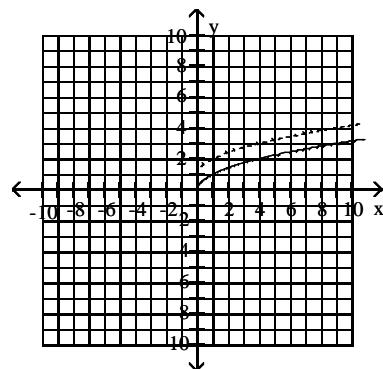

7) Begin by graphing the standard absolute value function $f(x) = |x|$ as a solid curve. Then use transformations of this graph to graph the function $g(x) = |x + 4| + 4$ as a dashed curve.

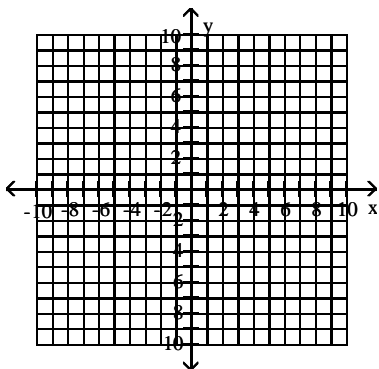

A)

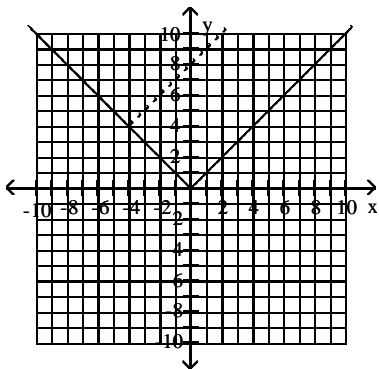

B)

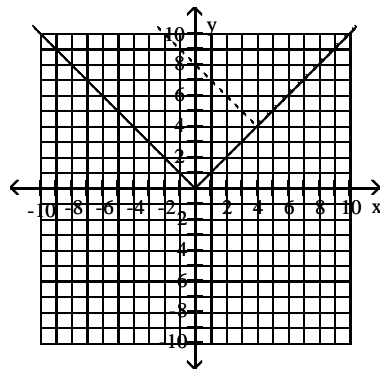

C)

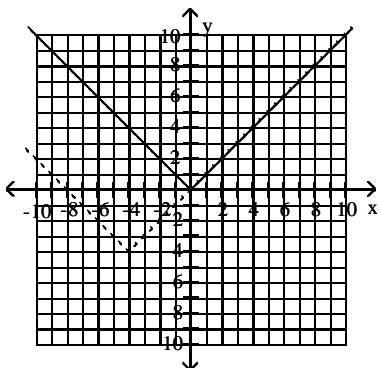

D)

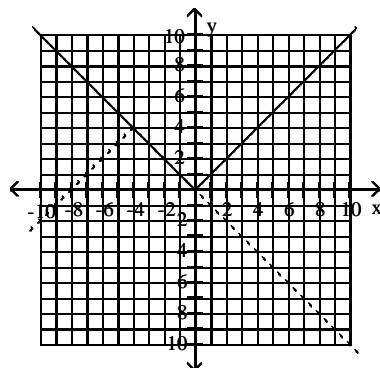

8) Begin by graphing the standard cubic function $f(x) = x^3$ as a solid curve. Then use transformations of this graph to graph the function $h(x) = (x - 2)^3$ as a dashed curve.

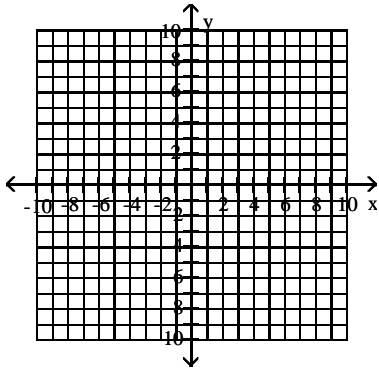

A)

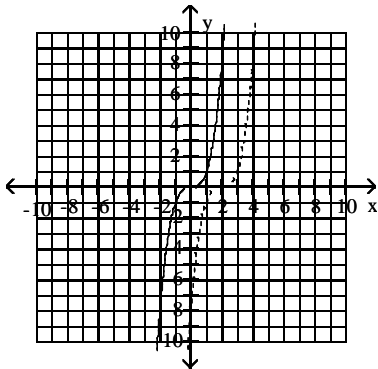

B)

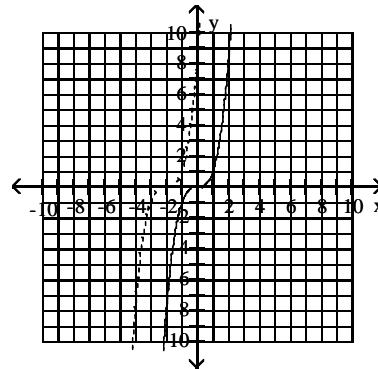

C)

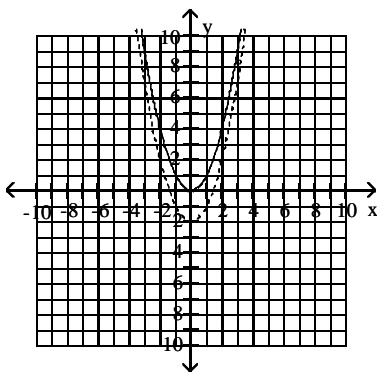

D)

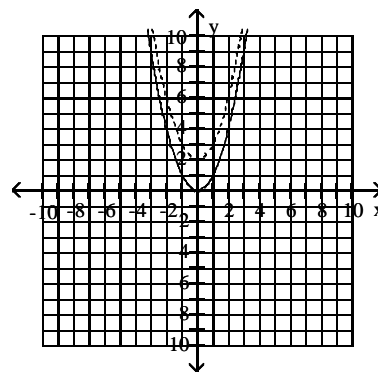

9) Begin by graphing the standard quadratic function $f(x) = x^2$ as a solid curve. Then use transformations of this graph to graph the function $h(x) = (x - 3)^2 + 2$ as a dashed curve.

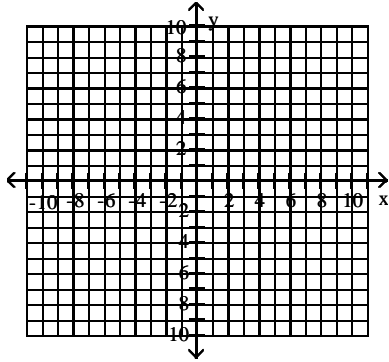

A)

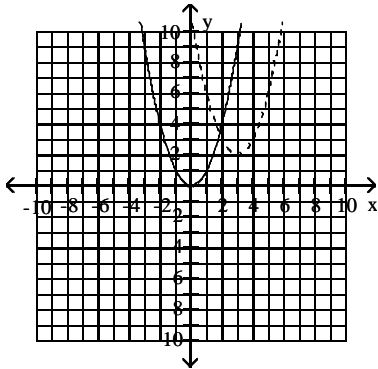

B)

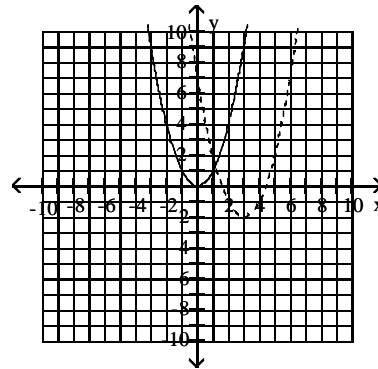

C)

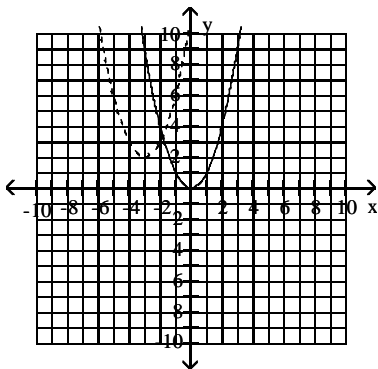

D)

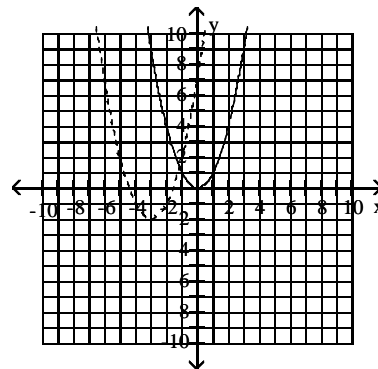

10) Begin by graphing the standard square root function $f(x) = \sqrt{x}$ as a solid curve. Then use transformations of this graph to graph the function $g(x) = \sqrt{x+1} + 1$ as a dashed curve.

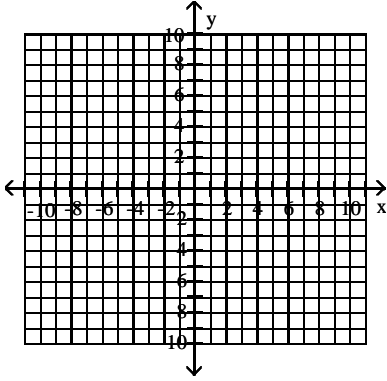

A)

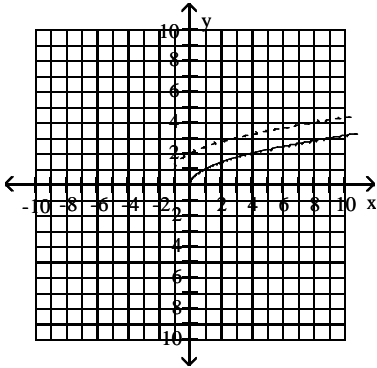

B)

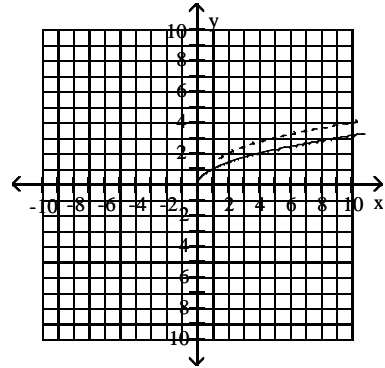

C)

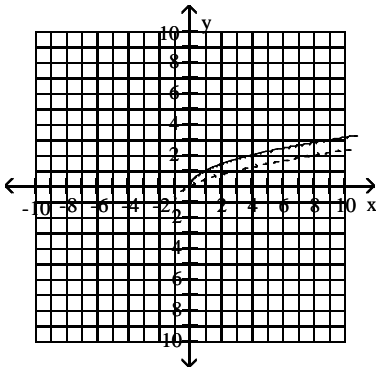

D)

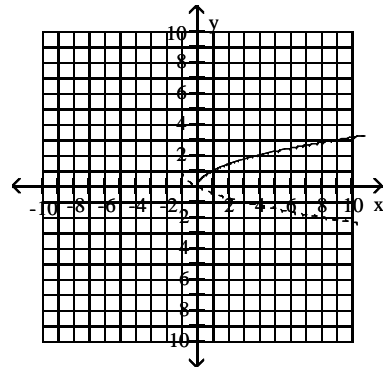

11) Begin by graphing the standard cubic function $f(x) = x^3$ as a solid curve. Then use transformations of this graph to graph the function $h(x) = (x - 5)^3 - 2$ as a dashed curve.

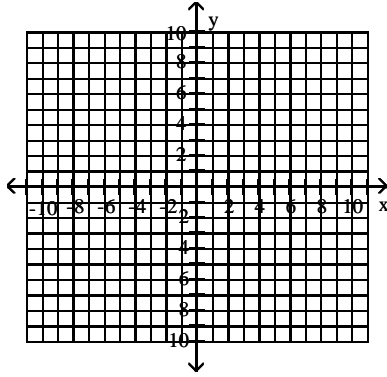

A)

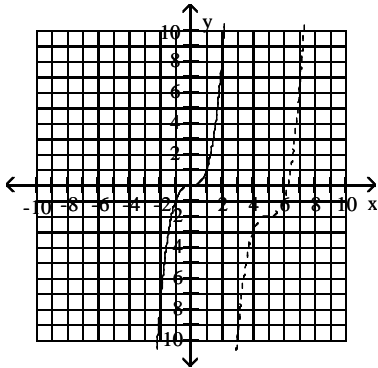

B)

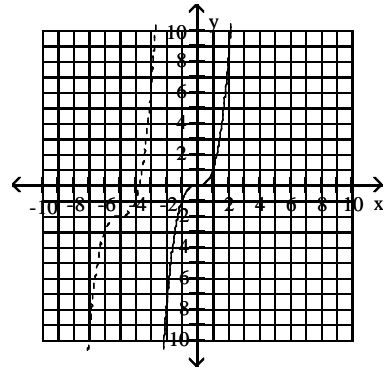

C)

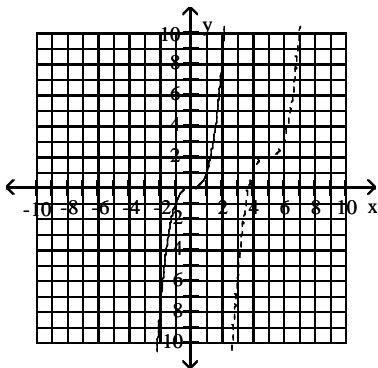

D)

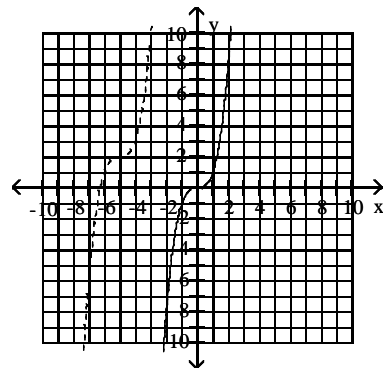

5 Solve Apps: Functions

MULTIPLE CHOICE. Choose the one alternative that best completes the statement or answers the question.

Solve the problem.

- 1) The function $f(t) = -0.13t^2 + 0.52t + 30.2$ models the U.S. population in millions, ages 65 and older, where t represents years after 1990. The function $g(t) = 0.5t^2 + 11.85t + 107.6$ models the total yearly cost of Medicare in billions of dollars, where t represents years after 1990. What does the function $\frac{g}{f}$ represent? Find $\frac{g}{f}(10)$.
- A) Cost per person in thousands of dollars. \$12.33 thousand
B) Cost per person in thousands of dollars. \$0.18 thousand
C) Cost per person in thousands of dollars. \$0.08 thousand
D) Cost per person in thousands of dollars. \$9.26 thousand
- 2) After being in business for t years, a manufacturer of radios is making $1500 + 400t + 30t^2$ units per year. The sales price in dollars per unit is calculated by using the formula $30 + 3t$. Write a formula for the manufacturer's yearly revenue $R(t)$ after t years.
- A) $R(t) = (1500 + 400t + 30t^2)(30 + 3t)$
B) $R(t) = (1500 + 400t + 30t^2) + (30 + 3t)$
C) $R(t) = (1500 + 400t + 30t^2) - (30 + 3t)$
D) $R(t) = \frac{(1500 + 400t + 30t^2)}{(30 + 3t)}$

0.7 Trigonometric Functions

1 Convert Degrees to Radians (in Terms of pi)

MULTIPLE CHOICE. Choose the one alternative that best completes the statement or answers the question.

Express the angle in radian measure in terms of π .

- 1) -90°
- A) $-\frac{\pi}{2}$
B) $-\frac{\pi}{3}$
C) $-\frac{\pi}{4}$
D) $-\frac{\pi}{8}$
- 2) 570°
- A) $\frac{19\pi}{6}$
B) $\frac{19\pi}{3}$
C) $\frac{19\pi}{12}$
D) $\frac{19\pi}{5}$
- 3) 144°
- A) $\frac{4\pi}{5}$
B) $\frac{8\pi}{5}$
C) $\frac{2\pi}{5}$
D) $\frac{3\pi}{5}$
- 4) 810°
- A) $\frac{9\pi}{2}$
B) 9π
C) $-\frac{9\pi}{4}$
D) $-\frac{9\pi}{2}$
- 5) 1080°
- A) 6π
B) 12π
C) $\frac{11\pi}{2}$
D) $\frac{13\pi}{2}$

2 Convert Radian Measure to Degrees

MULTIPLE CHOICE. Choose the one alternative that best completes the statement or answers the question.

Convert the radian measure to degrees. Round to the nearest hundredth if necessary.

1) $\frac{7\pi}{2}$

A) 630°

B) 540°

C) 675°

D) 720°

2) $\frac{4\pi}{5}$

A) 144°

B) 126°

C) 162°

D) 148°

3) $\frac{7\pi}{10}$

A) 126°

B) 108°

C) 81°

D) 144°

4) $\frac{5\pi}{36}$

A) 25°

B) 30°

C) 28°

D) 20°

5) $\frac{25\pi}{18}$

A) 250°

B) 240°

C) 260°

D) 275°

6) -2.0293

A) -116.27°

B) -115.77°

C) -116.97°

D) -115.27°

7) 3

A) 171.89°

B) 343.78°

C) 172.29°

D) 343.38°

8) 0.993

A) 56.89°

B) 113.79°

C) 569.47°

D) 3.12°

9) 103.1

A) 5907.19°

B) $11,814.40^\circ$

C) 5.48°

D) 323.90°

3 Convert Degrees to Radians (Decimal)

MULTIPLE CHOICE. Choose the one alternative that best completes the statement or answers the question.

Convert from degree measure to radian measure. Round to the nearest hundredth.

1) 299.5°

A) 5.23

B) 5.35

C) 5

D) 0

2) -81.8°

A) -1.43

B) -1.55

C) -1.29

D) -4.53

4 Evaluate Trig Function

MULTIPLE CHOICE. Choose the one alternative that best completes the statement or answers the question.

Find the exact value of the trigonometric function. Do not use a calculator or tables.

- 1) $\cos\left(\frac{\pi}{6}\right)$
A) $\frac{\sqrt{3}}{2}$ B) $\sqrt{3}$ C) $\frac{2\sqrt{3}}{3}$ D) $\frac{\sqrt{2}}{2}$
- 2) $\cos\left(\frac{\pi}{3}\right)$
A) $\frac{1}{2}$ B) $\frac{\sqrt{3}}{2}$ C) $\frac{2\sqrt{3}}{3}$ D) $\frac{\sqrt{2}}{2}$
- 3) $\sec\left(\frac{\pi}{4}\right)$
A) $\sqrt{2}$ B) $\frac{\sqrt{2}}{2}$ C) $\frac{2\sqrt{3}}{3}$ D) $\sqrt{3}$
- 4) $\sin\left(\frac{5\pi}{3}\right)$
A) $-\frac{\sqrt{3}}{2}$ B) $\frac{\sqrt{3}}{2}$ C) $-\frac{\sqrt{2}}{2}$ D) $\frac{\sqrt{2}}{2}$
- 5) $\cos\left(\frac{7\pi}{4}\right)$
A) $\frac{\sqrt{2}}{2}$ B) $-\frac{\sqrt{2}}{2}$ C) $\frac{\sqrt{3}}{2}$ D) $\frac{1}{2}$
- 6) $\tan\left(\frac{4\pi}{3}\right)$
A) $\sqrt{3}$ B) $-\sqrt{3}$ C) $-\frac{\sqrt{3}}{3}$ D) 1
- 7) $\sec\left(-\frac{3\pi}{2}\right)$
A) 1 B) -1 C) 0 D) Undefined
- 8) $\csc(\pi)$
A) 1 B) -1 C) 0 D) Undefined

5 Verify Trig Identity

MULTIPLE CHOICE. Choose the one alternative that best completes the statement or answers the question.

Which answer choice is equivalent to the given expression?

- 1) $\cos x \tan x \csc x$
A) 1 B) $\sin x$ C) $\cot x$ D) 2

2) $\sec u - \cos u$

A) $\tan u \sin u$

B) $\cot u \sin u$

C) $\sin u \csc u$

D) 1

3) $\cos^2 x - \sin^2 x$

A) $2 \cos^2 x - 1$

B) $3 \tan^2 x$

C) $\csc^2 x$

D) 1

4) $\cos^4 x - \sin^4 x$

A) $\cos^2 x - \sin^2 x$

B) $\sin^2 x - \cos^2 x$

C) $\tan x - \sin^2 x$

D) -1

5) $\frac{1 + \sin x}{\cos x}$

A) $\frac{\cos x}{1 - \sin x}$

B) $\frac{\sin x}{1 - \cos x}$

C) $\frac{\cos x}{1 + \sin x}$

6) $\frac{1}{1 + \sin x} + \frac{1}{1 - \sin x}$

A) $2 \sec^2 x$

B) $4 \tan^2 x$

C) $2 \csc^2 x$

D) $\sec^2 x - \sin x$

7) $\sec v - \tan v \sin v$

A) $\cos v$

B) $\cot v$

C) $\csc v$

D) $1 - \csc v$

8) $\frac{\sin 2x}{1 + \cos 2x}$

A) $\tan x$

B) $\cot x$

C) $\sec x$

D) $\csc x$

9) $\sin 2x \csc x$

A) $2 \cos x$

B) $2 \tan x$

C) $2 \cot x$

D) $2 \sec x$

10) $\frac{1 + \tan^2 x}{\tan^2 x}$

A) $\csc^2 x$

B) $\sin^2 x$

C) $\cos^2 x$

D) $\sec^2 x$

6 Graph Trig Function

MULTIPLE CHOICE. Choose the one alternative that best completes the statement or answers the question.

Sketch the graph on the coordinate system provided.

1) $y = -\sin 8x$

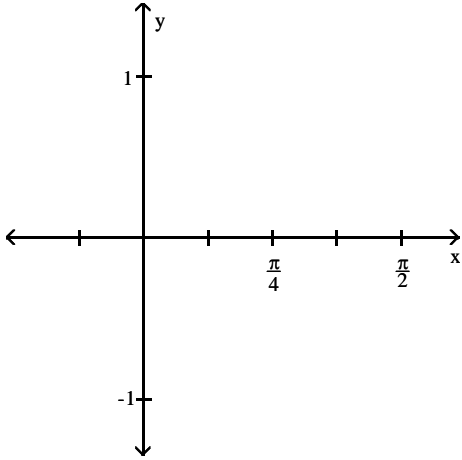

A)

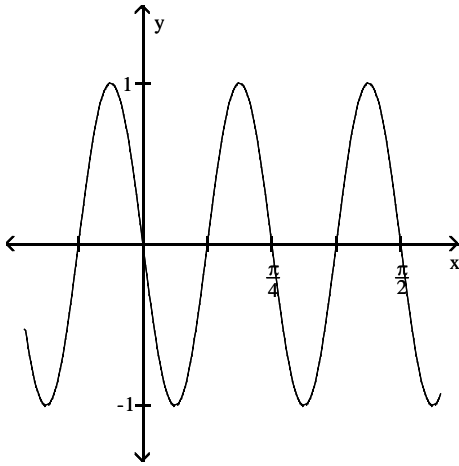

B)

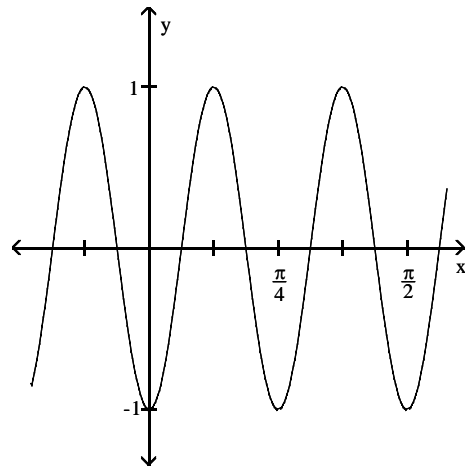

C)

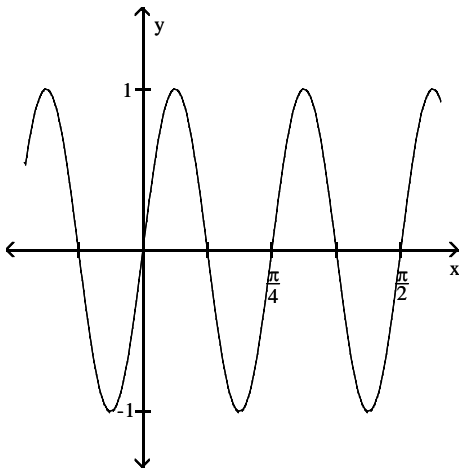

D)

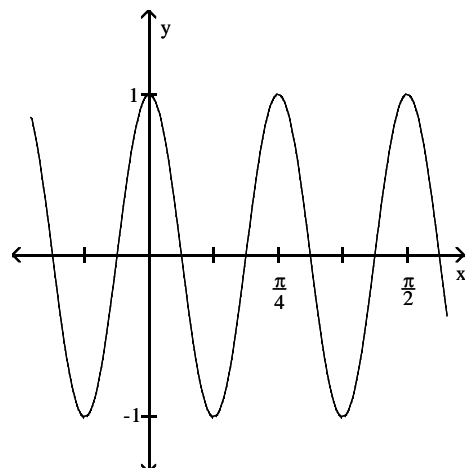

$$2) y = \sin\left(x - \frac{\pi}{4}\right)$$

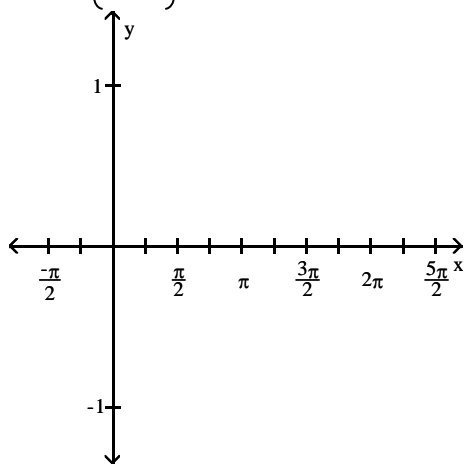

A)

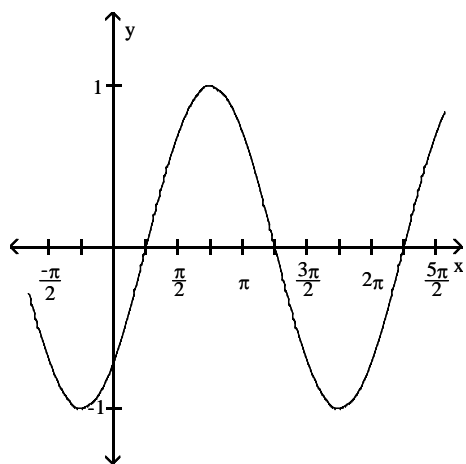

B)

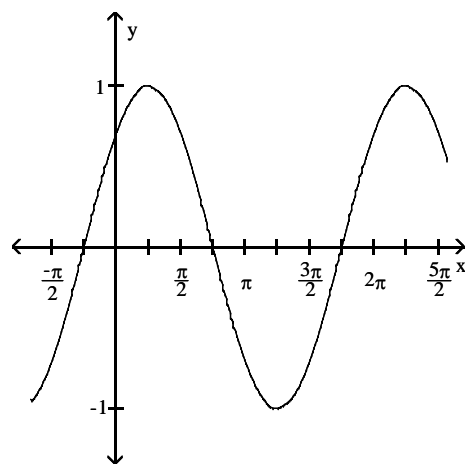

C)

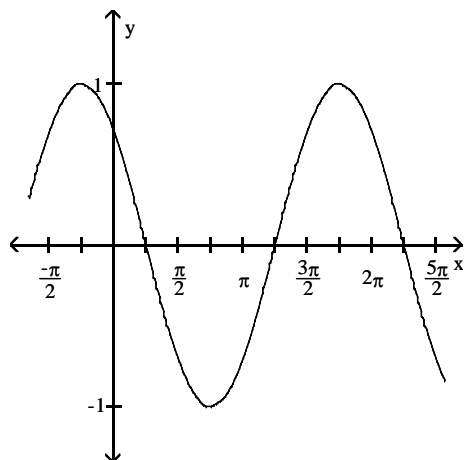

D)

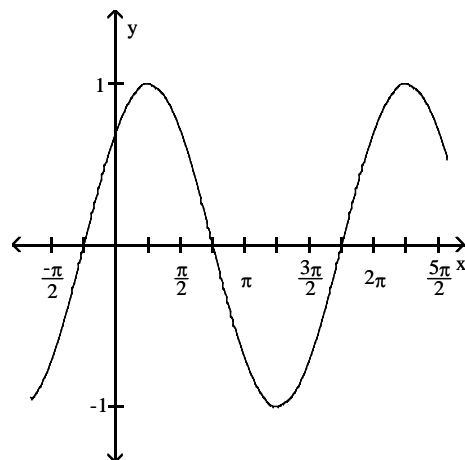

$$3) y = \cos\left(x + \frac{\pi}{4}\right)$$

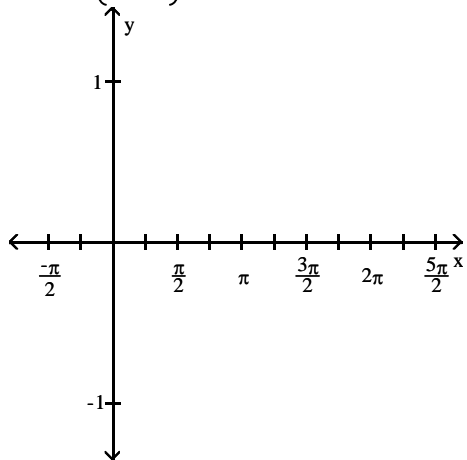

A)

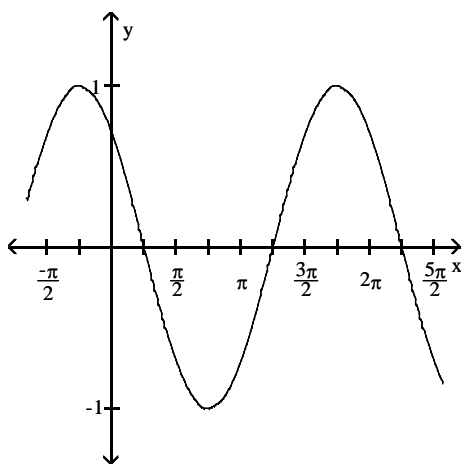

B)

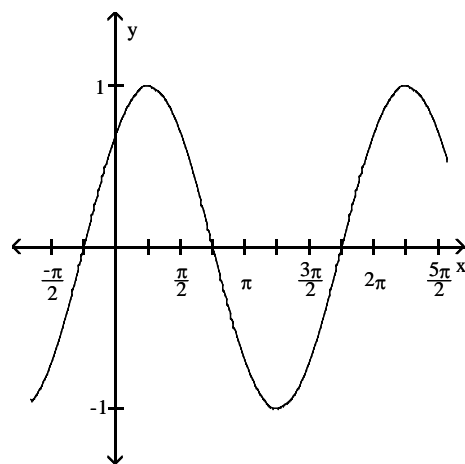

C)

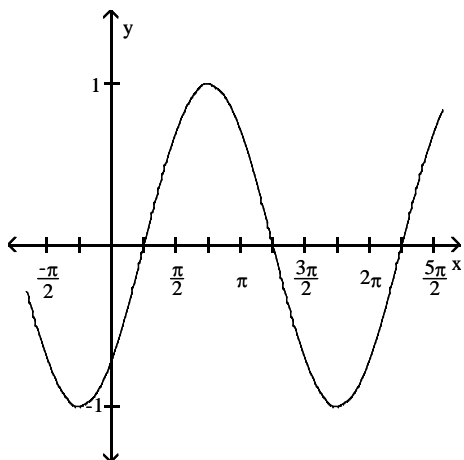

D)

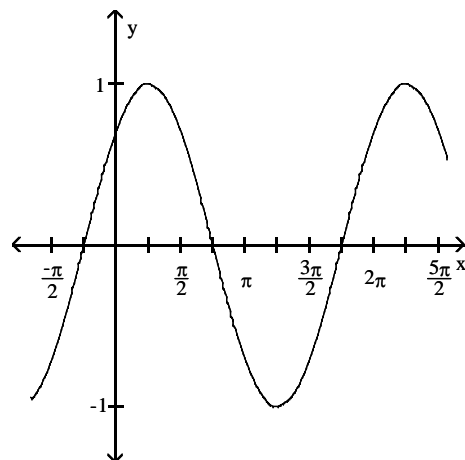

$$4) y = \sin\left(x + \frac{\pi}{4}\right) - 3$$

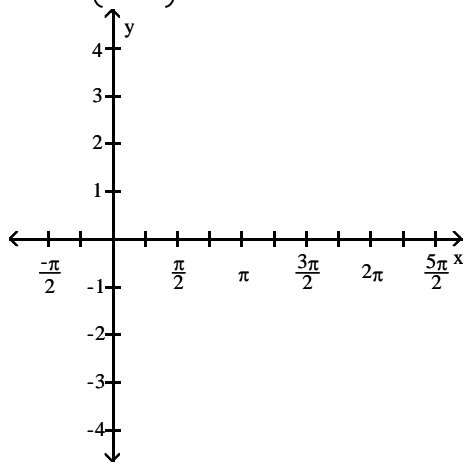

A)

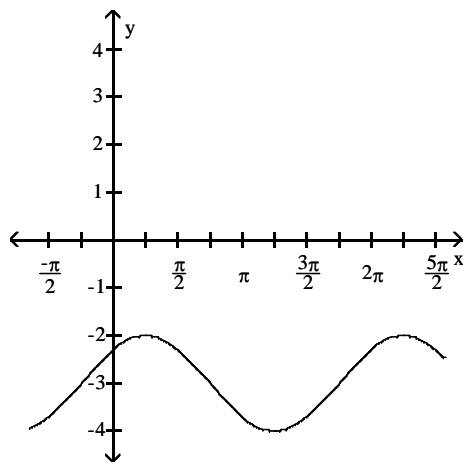

B)

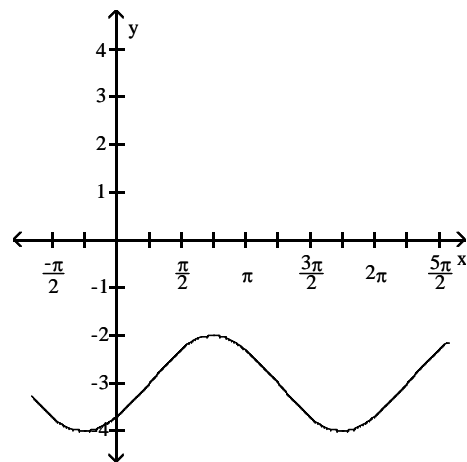

C)

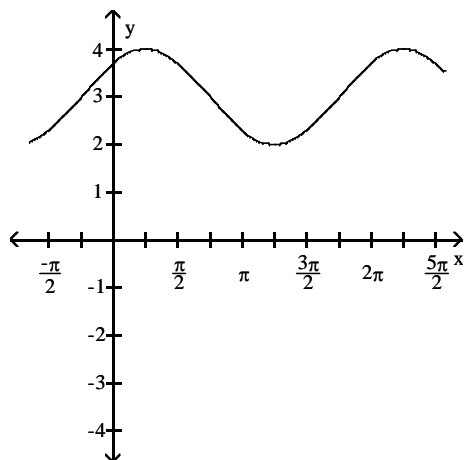

D)

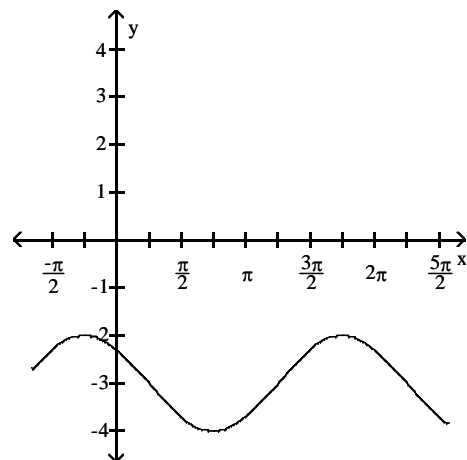

$$5) y = \cos\left(x - \frac{\pi}{4}\right) - 2$$

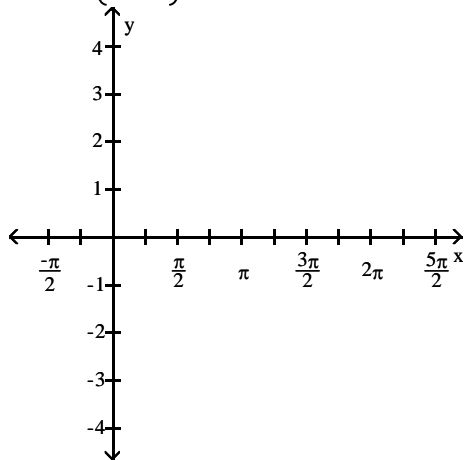

A)

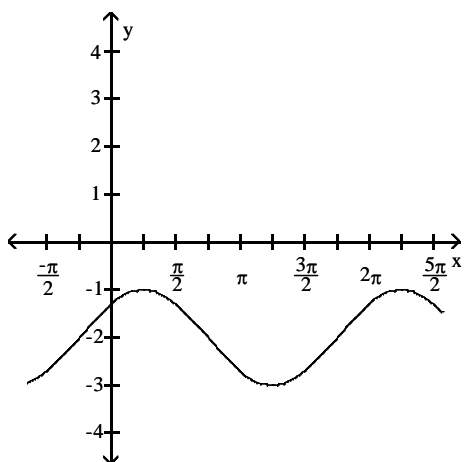

B)

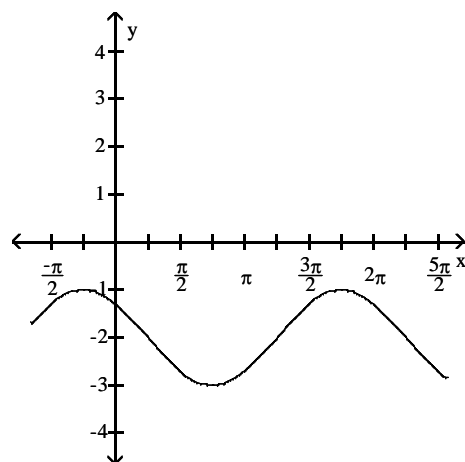

C)

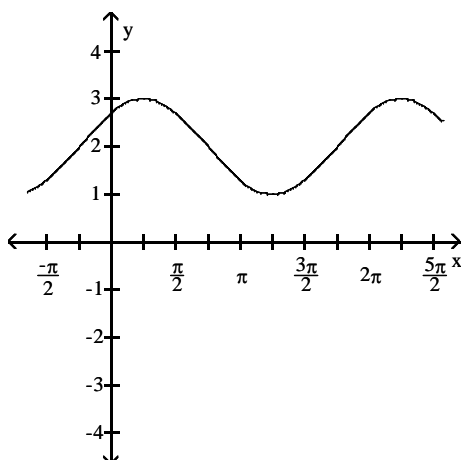

D)

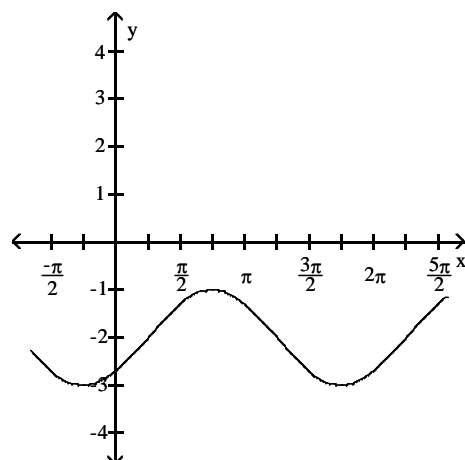

6) $y = \sin\left(x - \frac{\pi}{3}\right)$

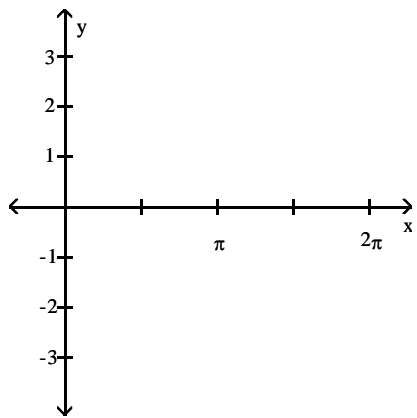

A)

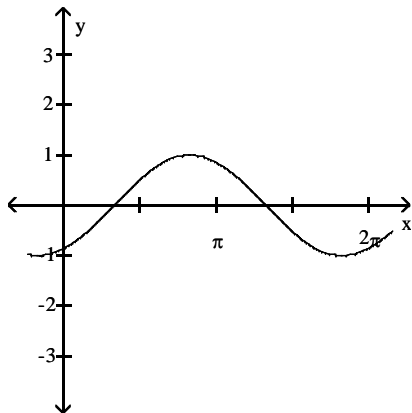

B)

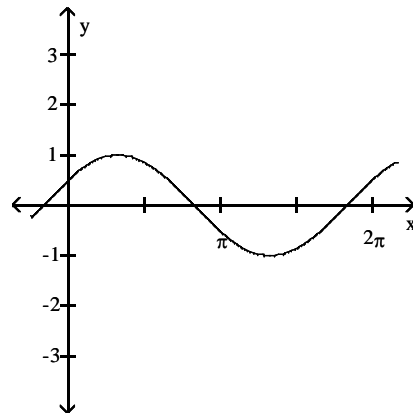

C)

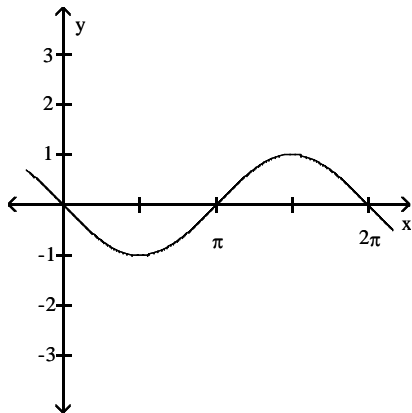

D)

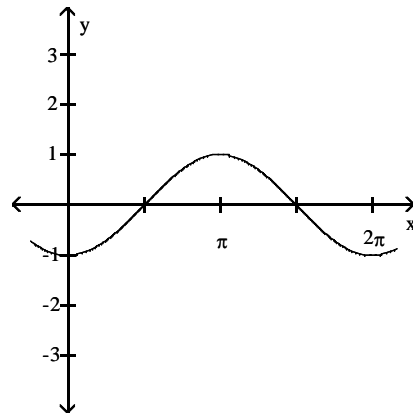

7) $y = \cos\left(x + \frac{\pi}{6}\right)$

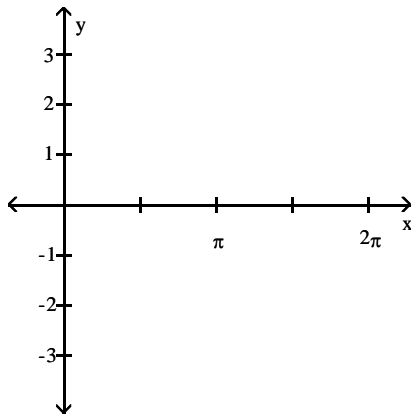

A)

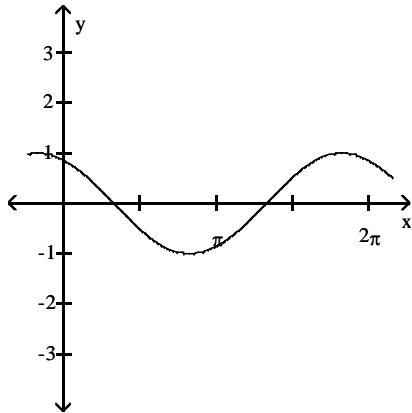

B)

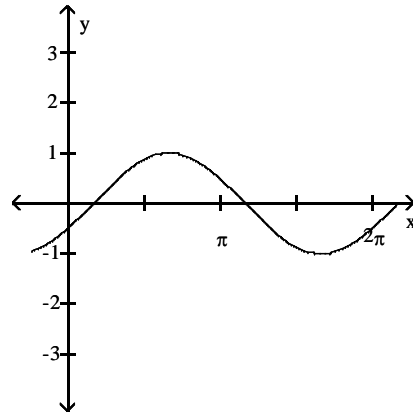

C)

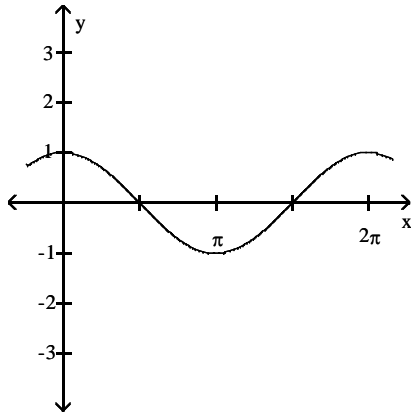

D)

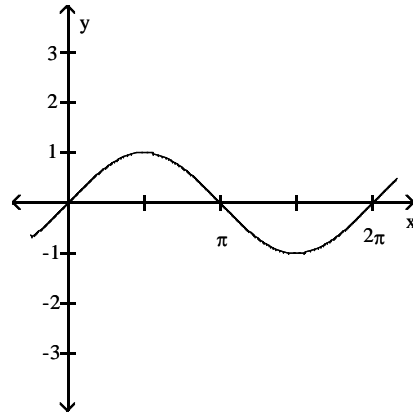

8) $y = 3 \sin(x + \frac{\pi}{2})$

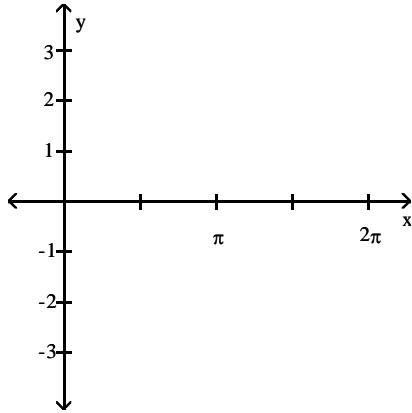

A)

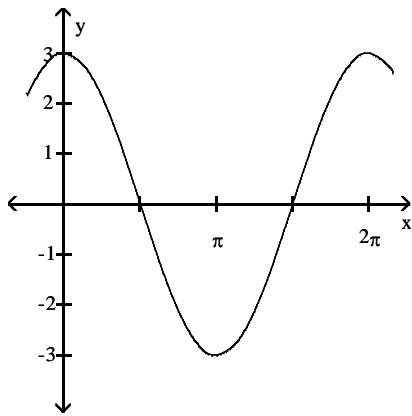

B)

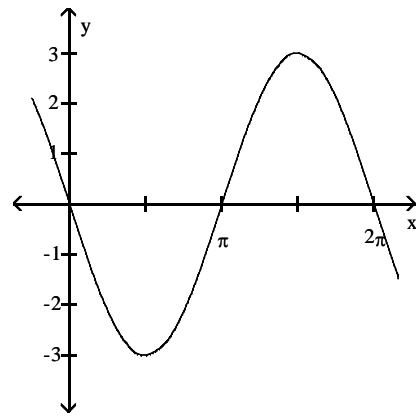

C)

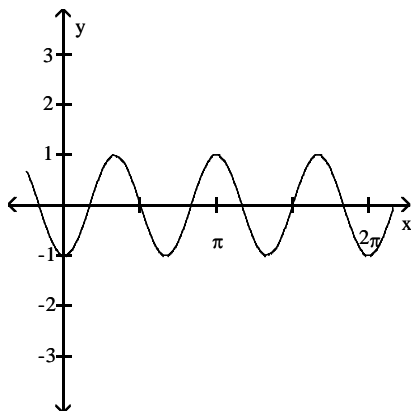

D)

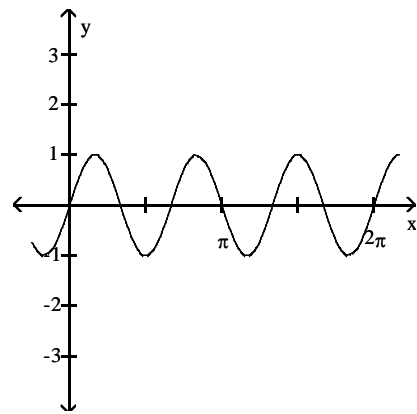

9) $y = 3 \cos(x - \frac{\pi}{2})$

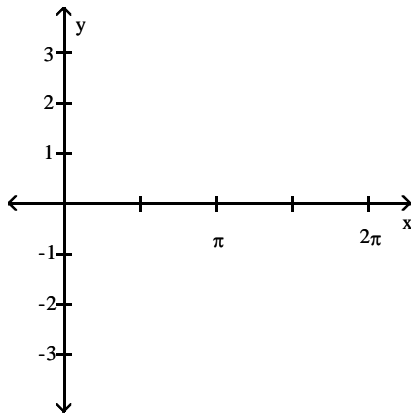

A)

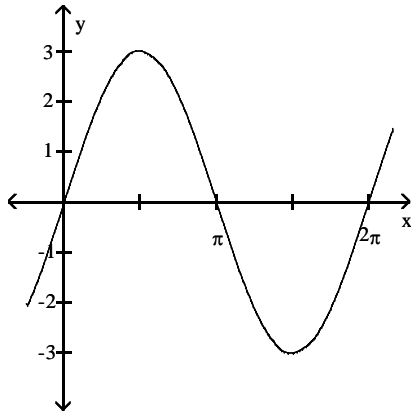

B)

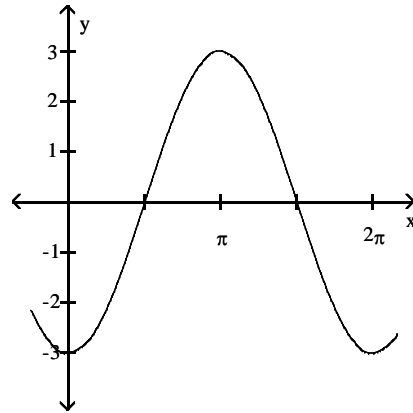

C)

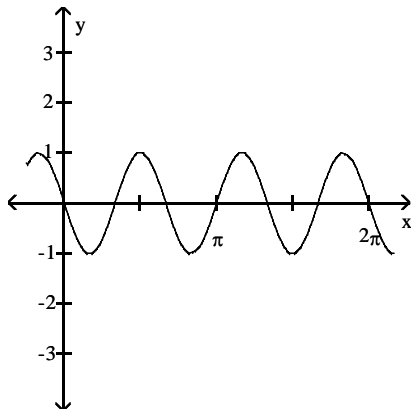

D)

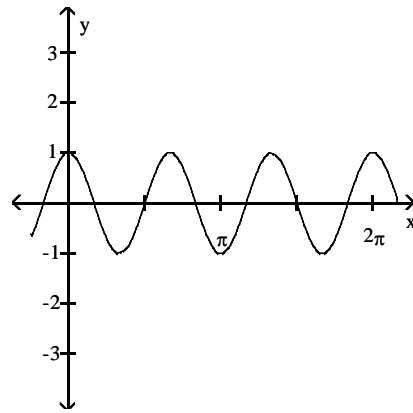

10) $y = \frac{1}{3} \sec x$

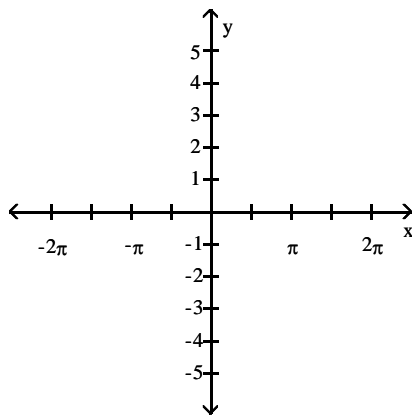

A)

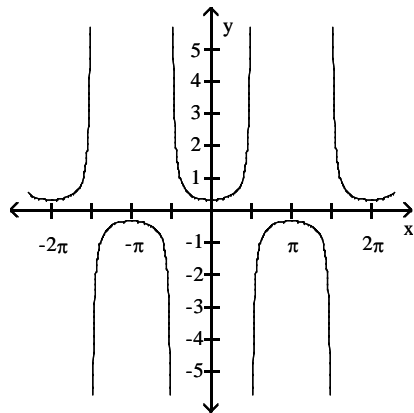

B)

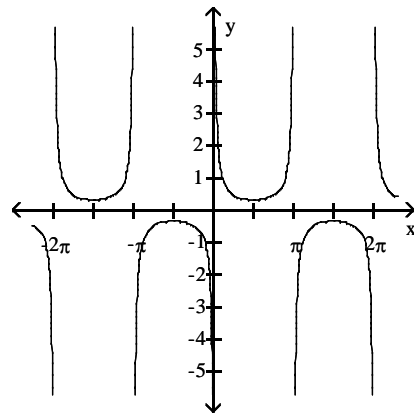

C)

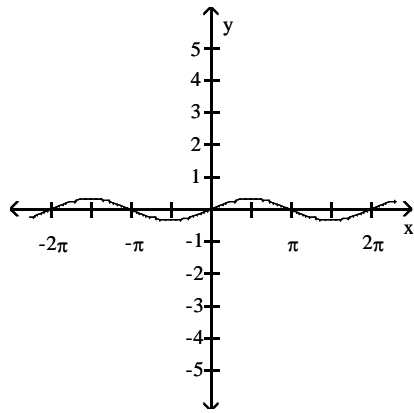

D)

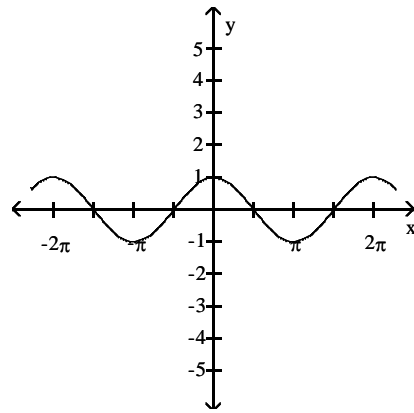

11) $y = 2 \csc x$

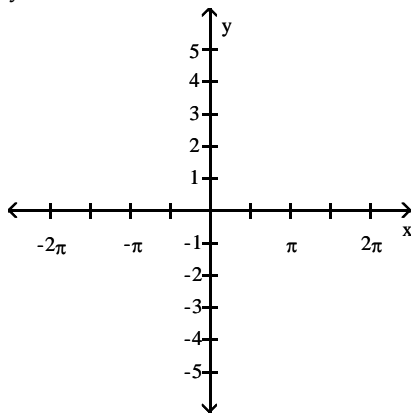

A)

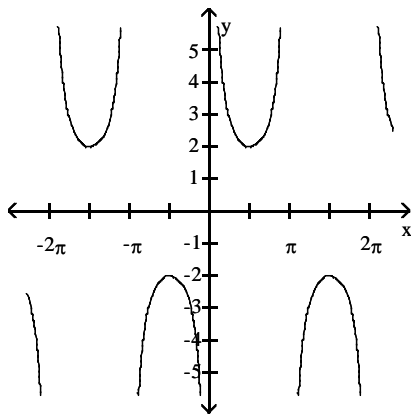

B)

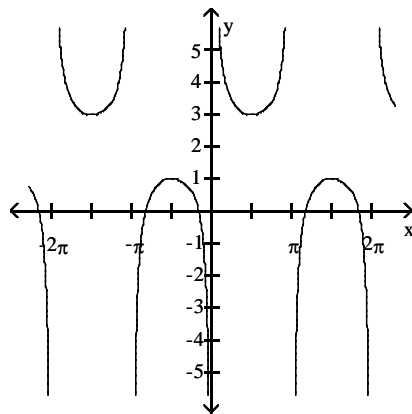

C)

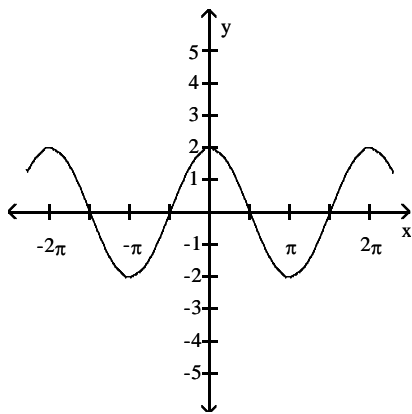

D)

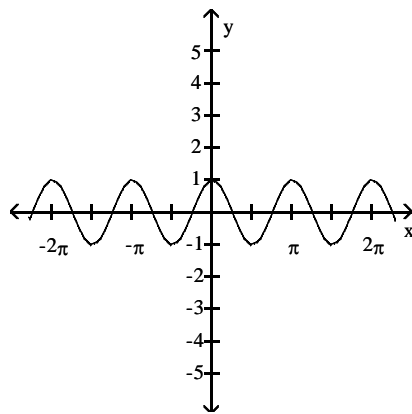

12) $y = 3 \cot x$

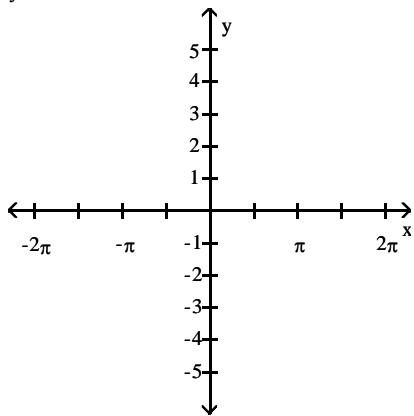

A)

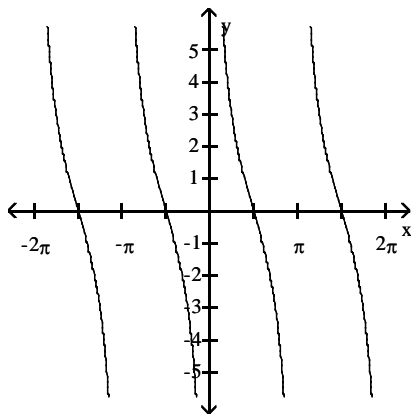

B)

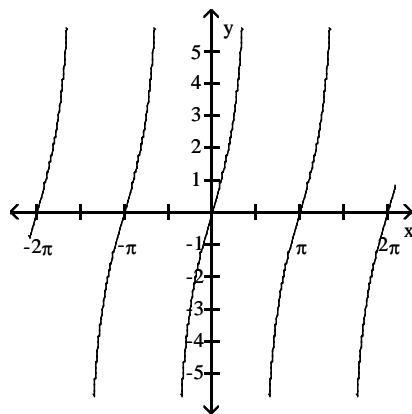

C)

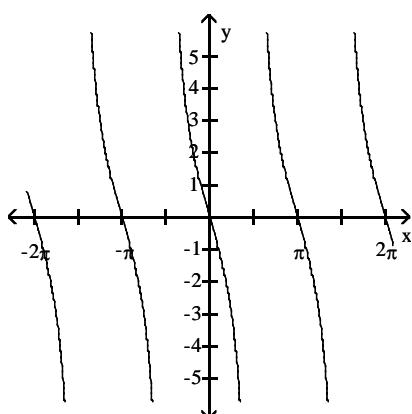

D)

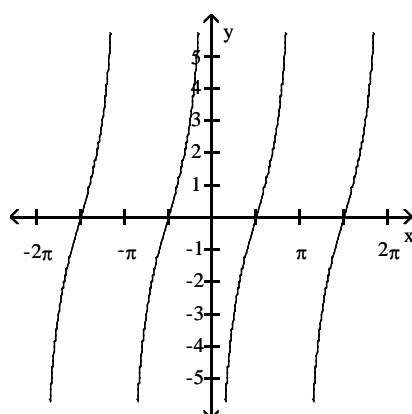

13) $y = 2 \tan x$

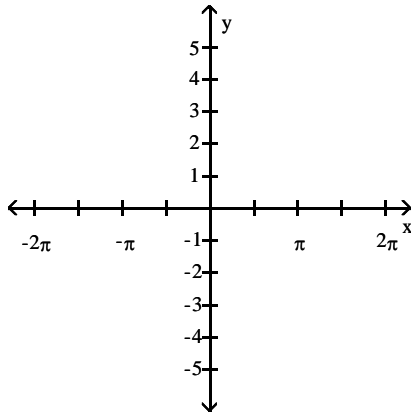

A)

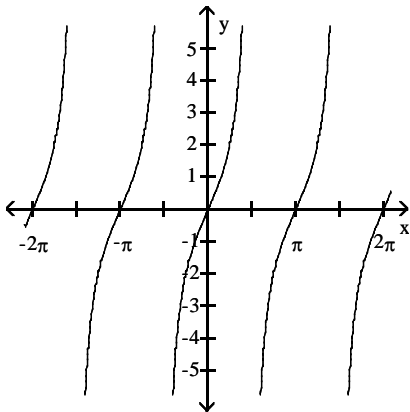

B)

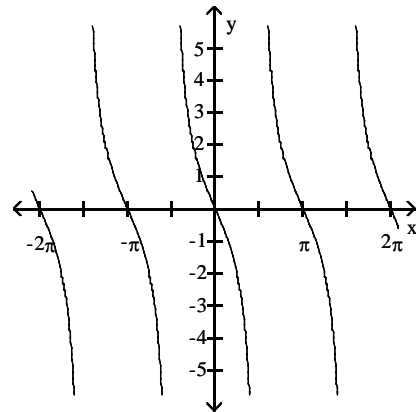

C)

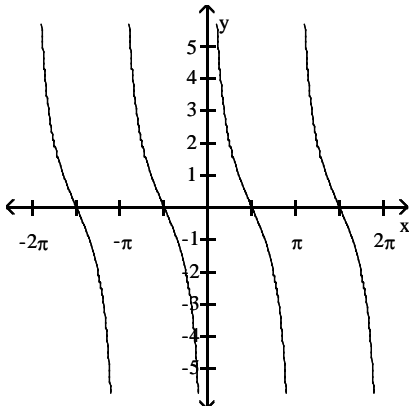

D)

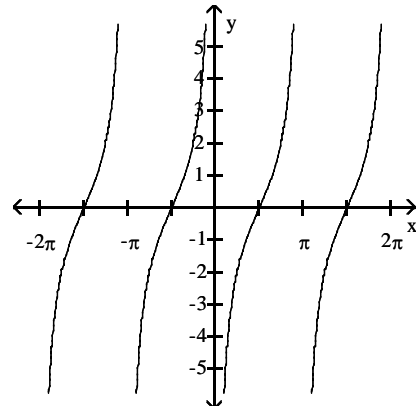

14) $y = \csc\left(x + \frac{\pi}{6}\right)$

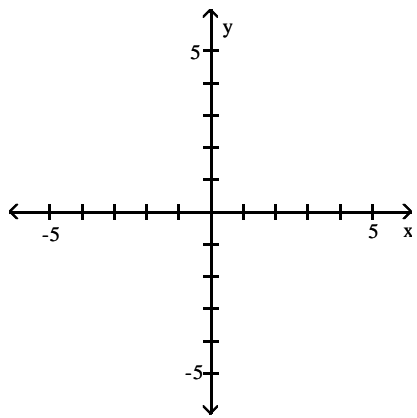

A)

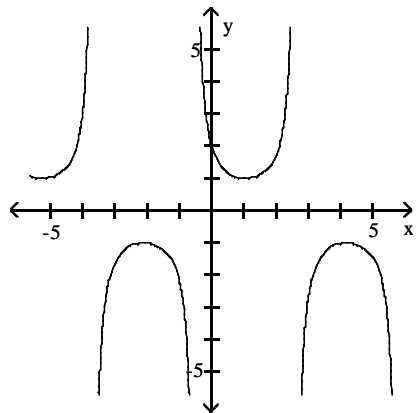

B)

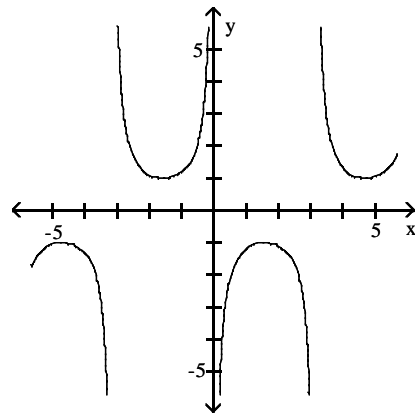

C)

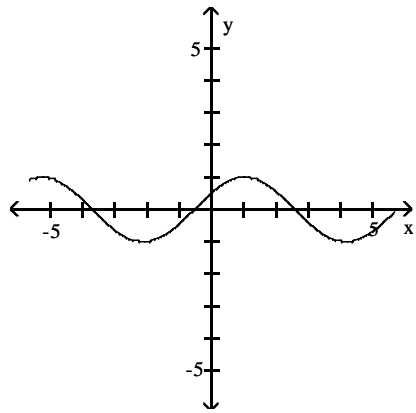

D)

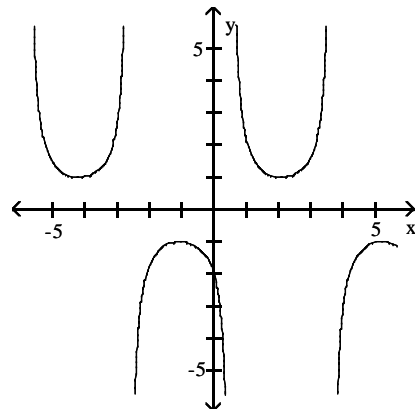

15) $y = \sec\left(x + \frac{\pi}{6}\right)$

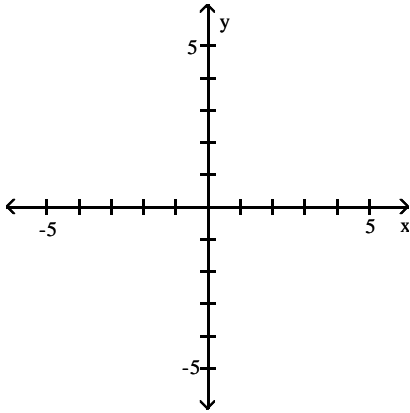

A)

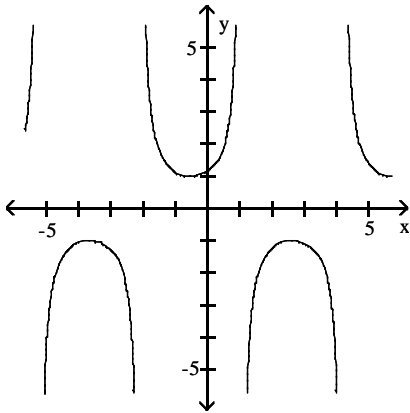

B)

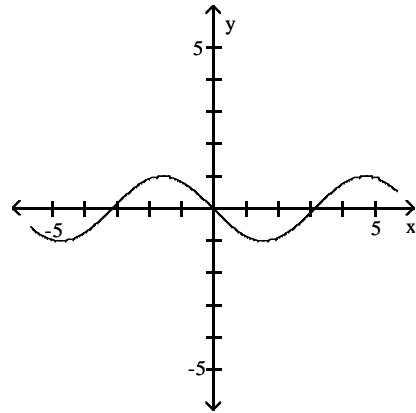

C)

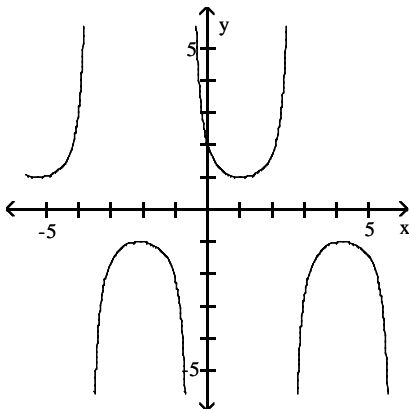

D)

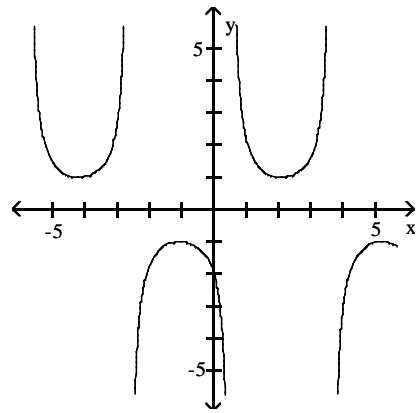

7 Determine Period, Amplitude, and Shifts

MULTIPLE CHOICE. Choose the one alternative that best completes the statement or answers the question.

Find the period, amplitude, or shift.

1) Find the amplitude of $y = 5 \cos\left(2x + \frac{\pi}{4}\right)$.

A) 5

B) 2

C) $\frac{\pi}{2}$

D) 10

2) Find the amplitude of $y = -3 \sin(2x + \frac{\pi}{4})$.

A) 3

B) 2

C) $\frac{\pi}{4}$

D) -6

3) Find the amplitude of $y = 2 \cos(3x - \pi)$.

A) 2

B) 3

C) π

D) 6

4) Find the amplitude of $y = -5 \sin(2x + \pi)$.

A) 5

B) 2

C) π

D) -10

5) Find the period of $y = -3 \sin(8x + \frac{\pi}{2})$.

A) $\frac{\pi}{4}$

B) 3

C) 8

D) π

6) Find the period of $y = -3 \cos(5x + \frac{\pi}{2})$.

A) $\frac{2\pi}{5}$

B) 3

C) $\frac{\pi}{2}$

D) π

7) Find the period of $y = 3 \sin(\frac{1}{2}x - \frac{\pi}{2})$.

A) 4π

B) 3π

C) 2π

D) $\frac{\pi}{2}$

8) Find the period of $y = -4 \cos(\frac{1}{3}x + \frac{\pi}{3})$.

A) 6π

B) 4π

C) 3π

D) $\frac{2\pi}{3}$

9) Find the shift for $y = -4 + 2 \sin(4x + \frac{\pi}{4})$.

A) $\frac{\pi}{16}$ to the left

B) $\frac{\pi}{16}$ to the right

C) $\frac{\pi}{4}$ to the left

D) $\frac{\pi}{8}$ to the right

10) Find the shift for $y = -2 + 3 \sin(4x - \frac{\pi}{4})$.

A) $\frac{\pi}{16}$ to the right

B) $\frac{\pi}{16}$ to the left

C) $\frac{\pi}{4}$ to the left

D) $\frac{\pi}{12}$ to the right

8 Determine if Trig Function is Even, Odd, or Neither

MULTIPLE CHOICE. Choose the one alternative that best completes the statement or answers the question.

Determine if the function is even, odd, or neither.

1) $f(t) = t \sin t$

A) even

B) odd

C) neither

D) both even and odd

2) $f(t) = \cos^2 t$

A) even

B) odd

C) neither

D) both even and odd

3) $f(t) = \csc t$

A) odd

B) even

C) neither

D) both even and odd

4) $f(t) = |\sin t|$

A) even

B) odd

C) neither

D) both even and odd

5) $f(t) = x - \cos x$

A) neither

B) even

C) odd

D) both even and odd

9 Evaluate Using Half-Angle Identities

MULTIPLE CHOICE. Choose the one alternative that best completes the statement or answers the question.

Find the exact value of the expression.

1) $\sin^2 \frac{\pi}{8}$

A) $\frac{2 - \sqrt{2}}{4}$

B) $\frac{2 + \sqrt{2}}{4}$

C) $\frac{1 - \sqrt{2}}{2}$

D) $2 - \sqrt{2}$

2) $\sin^2 \frac{\pi}{6}$

A) $\frac{1}{4}$

B) $\frac{3}{4}$

C) $\frac{2 - \sqrt{3}}{4}$

D) $2 - \sqrt{3}$

3) $\cos^3 \frac{\pi}{3}$

A) $\frac{1}{8}$

B) $\frac{\sqrt{3}}{2}$

C) $\frac{1}{2}$

D) $\frac{3}{8}$

10 Solve Apps: Trigonometric Functions

MULTIPLE CHOICE. Choose the one alternative that best completes the statement or answers the question.

Answer the question.

1) How far does a wheel of radius 3 feet roll along level ground in making 136 revolutions?

A) 816π feet

B) 408π feet

C) 1632π feet

D) 1224π feet

Ch. 0 Preliminaries

Answer Key

0.1 Real Numbers, Estimation, and Logic

1 Simplify Algebraic Expression

- 1) A
- 2) A
- 3) A
- 4) A
- 5) A
- 6) A
- 7) A
- 8) A
- 9) A
- 10) A
- 11) A
- 12) A
- 13) A
- 14) A
- 15) A
- 16) A
- 17) A
- 18) A
- 19) A
- 20) A
- 21) A

2 Properties of Zero

- 1) A
- 2) A
- 3) A

3 Write Fraction as Decimal

- 1) A
- 2) A

4 Write Repeating Decimal as Fraction

- 1) A
- 2) A

5 Tech: Decimal Approximation of Irrational Number

- 1) A
- 2) A
- 3) A
- 4) A

6 Write Converse and Contrapositive

- 1) A
- 2) A
- 3) A

7 * Logic and Proof

- 1) A
- 2) A
- 3) A
- 4) A
- 5) True. Explanations will vary.
- 6) False. Explanations will vary.
- 7) True. Explanations will vary.

8 Find Least Upper Bound

- 1) A
- 2) A
- 3) A

0.2 Inequalities and Absolute Values

1 Solve Inequality and Graph

- 1) A
- 2) A
- 3) A
- 4) A
- 5) A
- 6) A
- 7) A
- 8) A
- 9) A
- 10) A
- 11) A
- 12) A
- 13) A
- 14) A
- 15) A

2 Determine Truth of Inequality

- 1) TRUE
- 2) FALSE
- 3) FALSE
- 4) TRUE
- 5) FALSE
- 6) TRUE
- 7) TRUE
- 8) FALSE
- 9) A

3 Solve Compound Inequality (and)

- 1) A
- 2) A
- 3) A
- 4) A
- 5) D
- 6) A

4 Solve Compound Inequality (or)

- 1) A
- 2) A
- 3) A
- 4) A
- 5) D

5 Solve Absolute Value Inequality

- 1) A
- 2) A
- 3) D
- 4) A
- 5) A
- 6) A
- 7) A
- 8) D
- 9) A

10) A

6 Find Delta To Make True Statement

1) A

2) A

0.3 The Rectangular Coordinate System

1 Use Distance and Midpoint Formulas

1) A

2) A

3) A

4) A

5) A

6) A

7) A

8) A

9) A

2 Find Equation of Circle

1) A

2) A

3) A

4) A

5) A

6) A

7) A

8) A

9) A

10) A

11) A

12) A

3 Find Center and Radius of Circle

1) A

2) A

3) A

4) A

5) A

4 Find Slope of Line

1) A

2) A

3) A

4) A

5) A

6) A

7) A

8) A

5 Find Equation of Line

1) A

2) A

3) A

4) A

5) A

6) A

7) A

8) A

9) A

6 Find Slope and y-intercept

- 1) A
- 2) A
- 3) A
- 4) A
- 5) A
- 6) A

7 Find Value of Coefficient

- 1) A
- 2) A

8 Find Point of Intersection of Two Lines

- 1) A
- 2) A
- 3) A
- 4) A
- 5) A

9 Solve Apps: The Rectangular Coordinate System

- 1) A

10 Find Distance Between Point and Line

- 1) A
- 2) A

0.4 Graphs of Equations

1 Graph Equation

- 1) A
- 2) A
- 3) A
- 4) A
- 5) A
- 6) A
- 7) A
- 8) A
- 9) A
- 10) A
- 11) A
- 12) A
- 13) A
- 14) A
- 15) A
- 16) A
- 17) A
- 18) A
- 19) A
- 20) A
- 21) A
- 22) A
- 23) A
- 24) A
- 25) A
- 26) A
- 27) A
- 28) A
- 29) A
- 30) A
- 31) A

2 Tech: Graph Equation

- 1) A
- 2) A
- 3) A
- 4) A
- 5) A
- 6) A
- 7) A
- 8) A
- 9) A

3 Find Points of Intersection

- 1) A
- 2) A
- 3) A
- 4) A
- 5) A
- 6) A

4 Match General Equation to Graph

- 1) A
- 2) A
- 3) A
- 4) A
- 5) A
- 6) A

5 Find Distance Between Two Points on a Circle

- 1) A
- 2) A

0.5 Functions and Their Graphs

1 Evaluate Function

- 1) A
- 2) A
- 3) A
- 4) A
- 5) A
- 6) A
- 7) A
- 8) A
- 9) A
- 10) A
- 11) A
- 12) A
- 13) A
- 14) A
- 15) A
- 16) A

2 Determine If Graph Is a Function

- 1) A
- 2) A
- 3) A
- 4) A
- 5) A
- 6) A
- 7) A
- 8) A

- 9) A
- 10) A

3 Find Difference Quotient

- 1) A
- 2) A
- 3) A
- 4) A
- 5) A

4 Find Domain of Function

- 1) A
- 2) A
- 3) A
- 4) A
- 5) A
- 6) A
- 7) A
- 8) A
- 9) A
- 10) A
- 11) A

5 Determine If Function Is Even, Odd, or Neither

- 1) A
- 2) A
- 3) C
- 4) B
- 5) C
- 6) A
- 7) C
- 8) B
- 9) A
- 10) A

6 Solve Apps: Functions

- 1) A
- 2) A
- 3) A
- 4) A
- 5) A
- 6) A
- 7) A
- 8) A
- 9) A
- 10) A
- 11) A

7 Tech: Graph Function

- 1) A
- 2) A
- 3) A
- 4) A
- 5) A
- 6) A
- 7) A

8 Tech: Identify x-Intercepts

- 1) A
- 2) A

- 3) A
- 4) A

9 Tech: Find Range

- 1) A
- 2) A
- 3) A

10 Tech: Find Values Satisfying Statement

- 1) A
- 2) A

0.6 Operations on Functions

1 Find Sum, Difference, Product, or Quotient of Functions

- 1) A
- 2) A
- 3) A
- 4) A
- 5) A
- 6) A
- 7) A
- 8) A
- 9) A
- 10) A
- 11) A
- 12) A
- 13) A
- 14) A
- 15) A
- 16) A
- 17) A

2 Find Composition of Functions

- 1) A
- 2) A
- 3) A
- 4) A
- 5) A
- 6) A
- 7) A
- 8) A
- 9) A
- 10) A
- 11) A
- 12) A
- 13) A
- 14) A
- 15) A

3 Express Function as a Composition of Functions

- 1) A
- 2) A
- 3) A
- 4) A
- 5) A
- 6) A

4 Graph Function Using Translations

- 1) A
- 2) A

- 3) A
- 4) A
- 5) A
- 6) A
- 7) A
- 8) A
- 9) A
- 10) A
- 11) A

5 Solve Apps: Functions

- 1) A
- 2) A

0.7 Trigonometric Functions

1 Convert Degrees to Radians (in Terms of pi)

- 1) A
- 2) A
- 3) A
- 4) A
- 5) A

2 Convert Radian Measure to Degrees

- 1) A
- 2) A
- 3) A
- 4) A
- 5) A
- 6) A
- 7) A
- 8) A
- 9) A

3 Convert Degrees to Radians (Decimal)

- 1) A
- 2) A

4 Evaluate Trig Function

- 1) A
- 2) A
- 3) A
- 4) A
- 5) A
- 6) A
- 7) D
- 8) D

5 Verify Trig Identity

- 1) A
- 2) A
- 3) A
- 4) A
- 5) A
- 6) A
- 7) A
- 8) A
- 9) A
- 10) A

6 Graph Trig Function

- 1) A

- 2) A
- 3) A
- 4) A
- 5) A
- 6) A
- 7) A
- 8) A
- 9) A
- 10) A
- 11) A
- 12) A
- 13) A
- 14) A
- 15) A

7 Determine Period, Amplitude, and Shifts

- 1) A
- 2) A
- 3) A
- 4) A
- 5) A
- 6) A
- 7) A
- 8) A
- 9) A
- 10) A

8 Determine if Trig Function is Even, Odd, or Neither

- 1) A
- 2) A
- 3) A
- 4) A
- 5) A

9 Evaluate Using Half-Angle Identities

- 1) A
- 2) A
- 3) A

10 Solve Apps: Trigonometric Functions

- 1) A