

SOLUTIONS MANUAL



CHAPTER 2

Job Order Costing

ASSIGNMENT CLASSIFICATION TABLE

<u>Learning Objectives</u>	<u>Questions</u>	<u>Brief Exercises</u>	<u>Do It!</u>	<u>Exercises</u>	<u>A Problems</u>	<u>B Problems</u>
1. Explain the characteristics and purposes of cost accounting.	1, 2, 3, 4					
2. Describe the flow of costs in a job order costing system.	5, 6, 7, 8	1, 2	1	1, 2, 3, 4, 6, 7, 8, 9, 11	1A, 2A, 3A, 5A	1B, 2B, 3B, 5B
3. Explain the nature and importance of a job cost sheet.	9, 10, 11, 12	3, 4, 5	2	1, 2, 3, 6, 7, 8, 10, 12	1A, 2A, 3A, 5A	1B, 2B, 3B, 5B
4. Indicate how the predetermined overhead rate is determined and used.	13, 14, 15	6, 7	2	2, 3, 5, 6, 7, 8, 11, 12, 13	1A, 2A, 3A, 4A, 5A	1B, 2B, 3B, 4B, 5B
5. Prepare entries for jobs completed and sold.	16	8, 9	3	2, 3, 6, 7, 8, 9, 10, 11	1A, 2A, 3A, 5A	1B, 2B, 3B, 5B
6. Distinguish between under- and overapplied manufacturing overhead.	17, 18	10	4	4, 5, 12, 13	1A, 2A, 4A, 5A	1B, 2B, 4B, 5B

ASSIGNMENT CHARACTERISTICS TABLE

Problem Number	Description	Difficulty Level	Time Allotted (min.)
1A	Prepare entries in a job order cost system and job cost sheets.	Simple	30–40
2A	Prepare entries in a job order cost system and partial income statement.	Moderate	30–40
3A	Prepare entries in a job order cost system and cost of goods manufactured schedule.	Simple	30–40
4A	Compute predetermined overhead rates, apply overhead, and calculate under- or overapplied overhead.	Simple	20–30
5A	Analyze manufacturing accounts and determine missing amounts.	Complex	30–40
1B	Prepare entries in a job order cost system and job cost sheets.	Simple	30–40
2B	Prepare entries in a job order cost system and partial income statement.	Moderate	30–40
3B	Prepare entries in a job order cost system and cost of goods manufactured schedule.	Simple	30–40
4B	Compute predetermined overhead rates, apply overhead, and calculate under- or overapplied overhead.	Simple	20–30
5B	Analyze manufacturing accounts and determine missing amounts.	Complex	30–40

BLOOM'S TAXONOMY TABLE

Correlation Chart between Bloom's Taxonomy, Learning Objectives and End-of-Chapter Exercises and Problems

Learning Objective	Knowledge	Comprehension	Application	Analysis	Synthesis	Evaluation
1. Explain the characteristics and purposes of cost accounting.		Q2-1 Q2-2 Q2-3 Q2-4				
2. Describe the flow of costs in a job order costing system.	Q2-5 Q2-7 Q2-8	Q2-6 BE2-1	BE2-2 DI2-1 E2-1 E2-2 E2-3 E2-11 E2-4 P2-1A P2-3A P2-1B P2-2B P2-3B E2-4	P2-2A P2-5A P2-2B P2-5B		
3. Explain the nature and importance of a job cost sheet.	Q2-11 Q2-12	Q2-9 Q2-10	BE2-3 BE2-4 BE2-5 DI2-2 E2-1 E2-2 E2-3 E2-6 E2-7 E2-8 E2-10 E2-12 P2-1A P2-3A P2-3A P2-1B P2-3B P2-3B	P2-2A P2-5A P2-2B P2-5B		
4. Indicate how the predetermined overhead rate is determined and used.	Q2-15	Q2-13 Q2-14	BE2-6 BE2-7 DI2-2 E2-2 E2-3 E2-6 E2-7 E2-8 E2-11 E2-12 E2-13 P2-1A	E2-5 P2-2A P2-5A P2-2B P2-5B		
5. Prepare entries for jobs completed and sold.		Q2-16 BE2-9	BE2-8 DI2-3 E2-2 E2-3 E2-6 E2-7 E2-8 E2-9 E2-10 E2-11	P2-2A P2-5A P2-2B P2-5B		
6. Distinguish between under- and overapplied manufacturing overhead.		Q2-17 Q2-18 BE2-10	E2-12 E2-13 P2-1A P2-4A P2-1B P2-4B	DI2-4 E2-4 E2-5 P2-2A P2-5A P2-2B P2-5B		
Broadening Your Perspective		BYP2-4 BYP2-5 BYP2-6	BYP2-1	BYP2-3		BYP2-2 BYP2-7 BYP2-8 BYP2-9

LEARNING OBJECTIVES

1. EXPLAIN THE CHARACTERISTICS AND PURPOSES OF COST ACCOUNTING.
2. DESCRIBE THE FLOW OF COSTS IN A JOB ORDER COST ACCOUNTING SYSTEM.
3. EXPLAIN THE NATURE AND IMPORTANCE OF A JOB COST SHEET.
4. INDICATE HOW THE PREDETERMINED OVERHEAD RATE IS DETERMINED AND USED.
5. PREPARE ENTRIES FOR JOBS COMPLETED AND SOLD.
6. DISTINGUISH BETWEEN UNDER- AND OVERAPPLIED MANUFACTURING OVERHEAD.

CHAPTER REVIEW

Cost Accounting Systems

1. (L.O. 1) **Cost accounting** involves the measuring, recording, and reporting of product costs. From the data accumulated, both the total cost and unit cost of each product is determined.
2. A **cost accounting system** consists of accounts for the various manufacturing costs. These accounts are fully integrated into the general ledger of a company. An important feature of a cost accounting system is the use of a perpetual inventory system. Such a system provides information immediately on the cost of a product. The two basic types of cost accounting systems are (a) a job order cost system and (b) a process cost system.
3. Under a **job order cost system**, costs are assigned to each job or to each batch of goods.
4. A **process cost system** is used when a large volume of similar products are manufactured. Process costing accumulates product-related costs for a period of time instead of assigning costs to specific products or job orders.

Job Order Cost Flow

5. (L.O. 2) The **flow of costs** in job order cost accounting parallels the physical flow of the materials as they are converted into finished goods. There are two major steps in the flow of costs: (a) accumulating the manufacturing costs incurred and (b) assigning the accumulated costs to the work done.
6. A company **accumulates manufacturing costs** incurred by debits to Raw Materials Inventory, Factory Labor, and Manufacturing Overhead..
7. The **assignment of manufacturing costs** involves entries to Work in Process Inventory, Finished Goods Inventory, and Cost of Goods Sold.
8. The cost of raw materials purchased is debited to **Raw Materials Inventory** when materials are received.
9. **Factory labor costs** are debited to **Factory Labor** when they are incurred. The cost of factory labor consists of (1) gross earnings of factory workers, (2) employer payroll taxes on the earnings, and (3) fringe benefits incurred by the employer.
10. Manufacturing overhead costs are recognized as incurred and periodically through adjusting entries. The costs are debited to **Manufacturing Overhead**.

Assigning Manufacturing Costs to Work in Process

11. (L.O. 3) The assignment of manufacturing overhead costs to work in process involves debits to Work in Process Inventory and credits to Raw Materials Inventory, Factory Labor, and Manufacturing Overhead.

Job Cost Sheet

12. A **job cost sheet** is a form used to record the costs chargeable to a specific job and to determine the total and unit cost of the completed job. A separate job cost sheet is kept for each job. A **subsidiary ledger** consists of individual records for each individual item (each job). The Work in Process account is referred to as a **control account** because it summarizes the detailed data regarding specific jobs contained in the job cost sheets. Each entry to Work in Process Inventory must be accompanied by a corresponding posting to one or more job cost sheets.
13. Raw materials costs are assigned when the materials are issued by the storeroom. Work in Process Inventory is debited for direct materials used, Manufacturing Overhead is debited for indirect materials used, and Raw Materials Inventory is credited.
14. Factory labor costs are assigned to jobs on the basis of time tickets prepared when the work is performed. Work in Process Inventory is debited for direct labor costs, Manufacturing Overhead is debited for indirect labor costs, and Factory Labor is credited.

Manufacturing Overhead Costs

15. (L.O. 4) Manufacturing overhead relates to production operations as a whole and therefore cannot be assigned to specific jobs on the basis of actual costs incurred. Instead, manufacturing overhead is assigned to work in process and to specific jobs on an estimated basis through the use of a predetermined overhead rate.
16. The **predetermined overhead rate** is based on the relationship between estimated annual overhead costs and expected annual operating activity. This relationship is expressed in terms of a common activity base such as direct labor costs, direct labor hours, or machine hours.
 - a. The formula for the predetermined overhead rate is:
$$\frac{\text{Estimated Annual Overhead Costs}}{\text{Expected Annual Operating Activity}} = \text{Predetermined Overhead Rate}$$
 - b. The use of a predetermined overhead rate enables the company to determine the approximate total cost of each job when the job is completed.
 - c. In recent years, more companies are using **machine hours** as the activity base due to increased reliance on automation in manufacturing operations.
17. At the end of each month, the balance in Work in Process Inventory should equal the sum of the costs shown on the job cost sheets for unfinished jobs.

Assigning Costs to Finished Goods

18. (L.O. 5) When a job is completed, the total cost is debited to Finished Goods Inventory and credited to Work in Process Inventory. Finished Goods Inventory is a control account that controls individual finished goods records in a finished goods subsidiary ledger.
19. **Cost of goods sold** is recognized when a sale occurs by a debit to Cost of Goods Sold and a credit to Finished Goods Inventory (the sale is recorded with a debit to Accounts Receivable or Cash and a credit to Sales).

20. At the end of a period, financial statements are prepared that present aggregate data on all jobs manufactured and sold.
 - a. The cost of goods manufactured schedule has one new feature: in determining total manufacturing costs, **manufacturing overhead applied** is used instead of actual overhead costs.
 - b. The cost of goods manufactured schedule is prepared directly from the Work in Process Inventory account.

Under- or Overapplied Manufacturing Overhead

21. (L.O. 6) Manufacturing overhead may be under- or overapplied. When Manufacturing Overhead has a **debit balance**, overhead is said to be underapplied. **Underapplied overhead** means that the overhead assigned to work in process is less than the overhead incurred. When manufacturing overhead has a credit balance, overhead is overapplied. **Overapplied overhead** means that the overhead assigned to work in process is greater than the overhead incurred.
22. At the **end of the year**, any balance in Manufacturing Overhead is eliminated through an adjusting entry, usually to Cost of Goods Sold.
 - a. Underapplied overhead is debited to Cost of Goods Sold.
 - b. Overapplied overhead is credited to Cost of Goods Sold.

LECTURE OUTLINE

A. Cost Accounting Systems.

1. Cost accounting involves the measuring, recording, and reporting of product costs. From the data accumulated, companies determine both the total cost and the unit cost of each product.
2. A cost accounting system consists of accounts for the various manufacturing costs. These accounts are fully integrated into the general ledger of a company. An important feature of a cost accounting system is the use of a perpetual inventory system that provides immediate, up-to-date information on the cost of a product.
3. There are two basic types of cost accounting systems:

TEACHING TIP

ILLUSTRATION 2-1 identifies the two basic types of cost accounting systems and their characteristics.

- a. A job order system, where the company assigns costs to each job or to each batch of goods, and
- b. A process cost system, used when a company manufactures a large volume of similar products.

MANAGEMENT INSIGHT

Many companies suffer from poor cost accounting and sometimes make products they should not be selling. The managers of a diversified company thought they were making money, but a consulting firm found that the company had seriously underestimated costs.

What type of costs do you think the company had been underestimating?

Answer: It is most likely that the company failed to estimate and track overhead. In a highly diversified company, overhead associated with the diesel locomotive jobs may have been “lost” in the total overhead pool for the entire company.

B. Job Order Cost Flow.

1. The flow of costs (direct materials, direct labor, and manufacturing overhead) in job order cost accounting parallels the physical flow of the materials as they are converted into finished goods.

TEACHING TIP

ILLUSTRATION 2-2 provides an overview of the cost flows through the general ledger accounts in a job order cost system. Emphasize the two steps of (1) accumulating manufacturing costs incurred, and then (2) assigning accumulated costs to products.

2. There are two major steps in the flow of costs:
 - a. Accumulating the manufacturing costs incurred; these costs are accumulated in three accounts: Raw Materials Inventory, Factory Labor, and Manufacturing Overhead, and
 - b. Assigning the accumulated costs to Work in Process Inventory and eventually to Finished Goods Inventory and Cost of Goods Sold.
3. Three entries are made to accumulate the manufacturing costs incurred.

TEACHING TIP

ILLUSTRATION 2-3 provides an example of the journal entries required to accumulate the cost of raw materials, factory labor, and actual manufacturing overhead.

- a. When the company receives the raw materials it has purchased, it debits the cost of the materials to Raw Materials Inventory. Raw Materials Inventory is a control account. The subsidiary ledger consists of individual records for each item of raw materials.
- b. The cost of factory labor consists of gross earnings of factory workers, employer payroll taxes, and fringe benefits (sick pay, pensions, and vacation pay) incurred by the employer. Companies debit labor costs to Factory Labor as they incur those costs. Factory labor is assigned to work in process and manufacturing overhead at the end of the period.
- c. A company may record overhead costs periodically through adjusting entries by debiting Manufacturing Overhead. Manufacturing Overhead is a control account and the subsidiary ledger consists of individual accounts for each type of cost (factory utilities, factory repairs, etc.).

C. Assigning Manufacturing Costs to Work in Process.

1. A job cost sheet is a form used to record the costs chargeable to a specific job and to determine the total and unit costs of the completed job. The job cost sheets constitute the subsidiary ledger for the Work in Process Inventory account.
2. Each entry to Work in Process Inventory must be accompanied by a corresponding posting to one or more job cost sheets.
3. Three entries are made in assigning the manufacturing costs to work in process.

TEACHING TIP

ILLUSTRATION 2-4 provides an example of the journal entries required to assign direct materials, direct labor, and manufacturing overhead to Work in Process Inventory. Emphasize that actual overhead costs are not assigned to Work in Process; instead, overhead is applied using a predetermined overhead rate.

- a. Materials requisition slips indicate the quantity and type of materials withdrawn and the account to be charged. Companies charge direct materials to Work in Process Inventory and indirect materials to Manufacturing Overhead.
- b. Companies assign factory labor costs to jobs on the basis of time tickets prepared when the work is performed. The time ticket indicates the hours worked, the account and job to be charged, and the total labor cost. Companies debit the Work in Process Inventory account for direct labor, and Manufacturing Overhead for indirect labor.
- c. Companies assign manufacturing overhead to work in process and to specific jobs on an estimated basis through the use of a predetermined overhead rate. Using a predetermined overhead rate enables a cost to be determined for a job immediately.

MANAGEMENT INSIGHT

Competitors often want to know the cost of a competing product. For a price, a company called iSuppli will disassemble sophisticated electronics and tell you what it would cost to replicate the product. The difference between the cost of the parts and the cost of the labor to assemble the parts isn't all profit. There are nonproduction costs such as research, design, marketing, patent fees, and selling costs.

What type of costs are research, design, marketing, patent fees, and selling costs, and how are they treated for accounting purposes?

Answer: Product costs include materials, labor, and overhead. Costs not related to production, such as research, design, marketing, patent fees, and selling costs, are period costs which are expensed in the period that they are incurred.

4. The predetermined overhead rate is based on the relationship between estimated annual overhead costs and expected annual operating activity, expressed in terms of a common activity base.

TEACHING TIP

Use **ILLUSTRATION 2-4** again to discuss how a predetermined overhead rate is calculated. Emphasize the importance of choosing an appropriate activity as a base for assigning overhead.

- a. The company may state the activity in terms of direct labor costs, direct labor hours, machine hours, or any other measure that will provide an equitable basis for applying overhead costs to jobs.
 - b. The predetermined overhead rate is established at the beginning of the year.
5. Using a predetermined overhead rate enables the company to determine the approximate total cost of each job when it completes the job.
 6. At the end of each month, the balance in Work in Process Inventory should equal the sum of the costs shown on the job cost sheets of unfinished jobs.

D. Assigning Costs to Finished Goods and Cost of Goods Sold.

1. When a job is completed, the company summarizes the costs in the applicable job cost sheet and debits Finished Goods Inventory. Finished Goods Inventory is a control account that controls individual finished goods records in a finished goods subsidiary ledger. Postings to the finished goods records are made directly from completed job cost sheets.
2. Companies recognize cost of goods sold when each sale occurs. Each sale requires an entry debiting Cash or Accounts Receivable and crediting Sales for the selling price and a second entry debiting Cost of Goods Sold and crediting Finished Goods Inventory for the cost of the goods.

TEACHING TIP

ILLUSTRATION 2-5 provides an example of the journal entries required to assign manufacturing costs to finished goods and to record a sale and the cost of completed units sold.

3. Job cost sheets for a service company keep track of materials, labor, and overhead used on a particular job similar to a manufacturer.

SERVICE COMPANY INSIGHT

Jet engines are one of the many products made by the industrial operations division of General Electric. At prices as high as \$30 million per engine GE does its best to keep track of costs. Because of the high product costs, both the engines themselves and the subsequent service are most likely accounted for using job order costing. GE needs good cost records for its service jobs in order to control its costs.

Explain why GE would use job order costing to keep track of the cost of repairing a malfunctioning engine for a major airline.

Answer: GE operates in competitive environment. Other companies offer competing bids to win service contracts on GE airplane engines. GE needs to know what it costs to repair engines, so that it can present competitive bids while still generating a reasonable profit.

E. Job Order Cost Flows and Reporting Job Cost Data.

1. A job order cost accounting system may be illustrated in a flow chart.

TEACHING TIP

ILLUSTRATION 2-6 provides a flow chart of the cost flows through the general ledger accounts for the examples used in Illustrations 2-3, 2-4, and 2-5.

2. Entries in the job cost system also provide a summary of the inventory control accounts and source documents for assigning costs to jobs.

TEACHING TIP

ILLUSTRATION 2-7 identifies the major source documents used to make entries in a job order cost system.

3. The cost of goods manufactured schedule is the same as for companies that do not use job order costing with one exception: manufacturing overhead applied, rather than actual overhead costs, is added to direct materials and direct labor to determine total manufacturing costs.

F. Under- or Overapplied Manufacturing Overhead.

1. Underapplied overhead means that the overhead assigned to work in process is less than the overhead incurred (when Manufacturing Overhead has a debit balance).
2. Overapplied overhead means that the overhead assigned to work in process is greater than the overhead incurred (when Manufacturing Overhead has a credit balance).

TEACHING TIP

ILLUSTRATION 2-8 contrasts actual Manufacturing Overhead with Applied Overhead and indicates whether overhead is under- or overapplied.

3. At the end of the year, the company eliminates any balance in Manufacturing Overhead by an adjusting entry. Under- or overapplied overhead is generally considered to be an adjustment to cost of goods sold.
4. The company debits underapplied overhead to cost of goods sold and it credits overapplied overhead to cost of goods sold.

20 MINUTE QUIZ

Circle the correct answer.

True/False

1. Under a job order system, the company assigns costs to each job, or each batch of goods, to fill a specific customer order or replenish inventory.
True False
2. Manufacturing costs incurred in a job order system are accumulated by debits to Purchases, Factory Labor, and Manufacturing Overhead.
True False
3. Each debit to Work in Process Inventory must be accompanied by a corresponding posting to one or more job cost sheets.
True False
4. Manufacturing overhead costs *cannot* be traced directly to a specific job.
True False
5. The requisition of factory supplies to production requires a debit to the Manufacturing Overhead account.
True False
6. Actual overhead costs are debited to the Manufacturing Overhead account.
True False
7. The entry to record the cost of goods sold includes a debit to Finished Goods Inventory.
True False
8. A debit balance in the Manufacturing Overhead Account at the end of the period indicates that overhead has been overapplied.
True False
9. In preparing the costs of goods manufactured schedule in job order costing, manufacturing costs include direct materials used, direct labor used, and manufacturing overhead applied.
True False
10. A job cost sheet is a form used to record the costs chargeable to a specific job and to determine the total and unit cost of the completed job.
True False

Multiple Choice

1. A job order cost sheet includes
 - a. the selling price of the job.
 - b. a total when a job is completed and transferred to cost of goods sold.
 - c. all manufacturing costs for a job.
 - d. all manufacturing overhead costs for the period.

2. Companies assign raw materials costs to jobs
 - a. By debiting Raw Materials Inventory and crediting Work in Process.
 - b. Based on a predetermined rate.
 - c. In response to verbal requests for indirect materials such as supplies.
 - d. Using any of the inventory costing methods (FIFO, LIFO, or average-cost).

3. In a job order cost system, debits to Work in Process Inventory originate from all of the following *except*
 - a. applying the predetermined overhead rate.
 - b. assigning direct labor from time tickets.
 - c. assigning actual manufacturing overhead costs to jobs.
 - d. assigning direct materials from requisition slips.

4. The predetermined overhead rate is computed by dividing estimated
 - a. level of activity by estimated overhead costs.
 - b. level of activity by expected overhead costs.
 - c. overhead costs by estimated cost of jobs.
 - d. overhead costs by expected activity base.

5. If annual overhead costs are expected to be \$1,000,000 and 200,000 total labor hours are anticipated (80% direct, 20% indirect), the overhead rate based on direct labor hours is
 - a. \$6.25.
 - b. \$5.00.
 - c. \$25.00.
 - d. \$4.00.

ANSWERS TO QUIZ

True/False

- | | |
|----------|----------|
| 1. True | 6. True |
| 2. False | 7. False |
| 3. True | 8. False |
| 4. True | 9. True |
| 5. True | 10. True |

Multiple Choice

1. c.
2. d.
3. c.
4. d.
5. a.

ILLUSTRATION 2-1 COST ACCOUNTING SYSTEMS

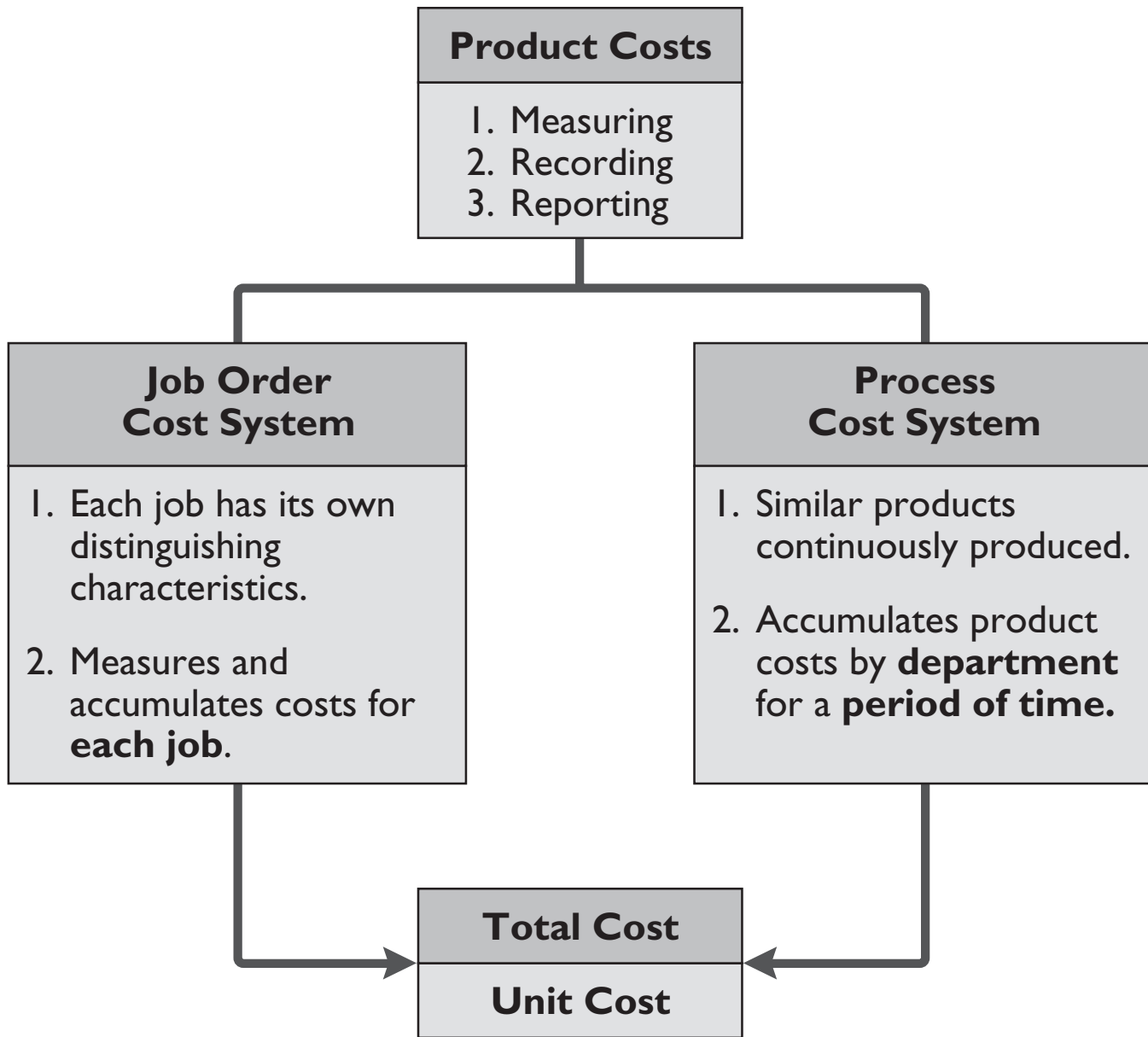

ILLUSTRATION 2-2 JOB ORDER COST FLOWS

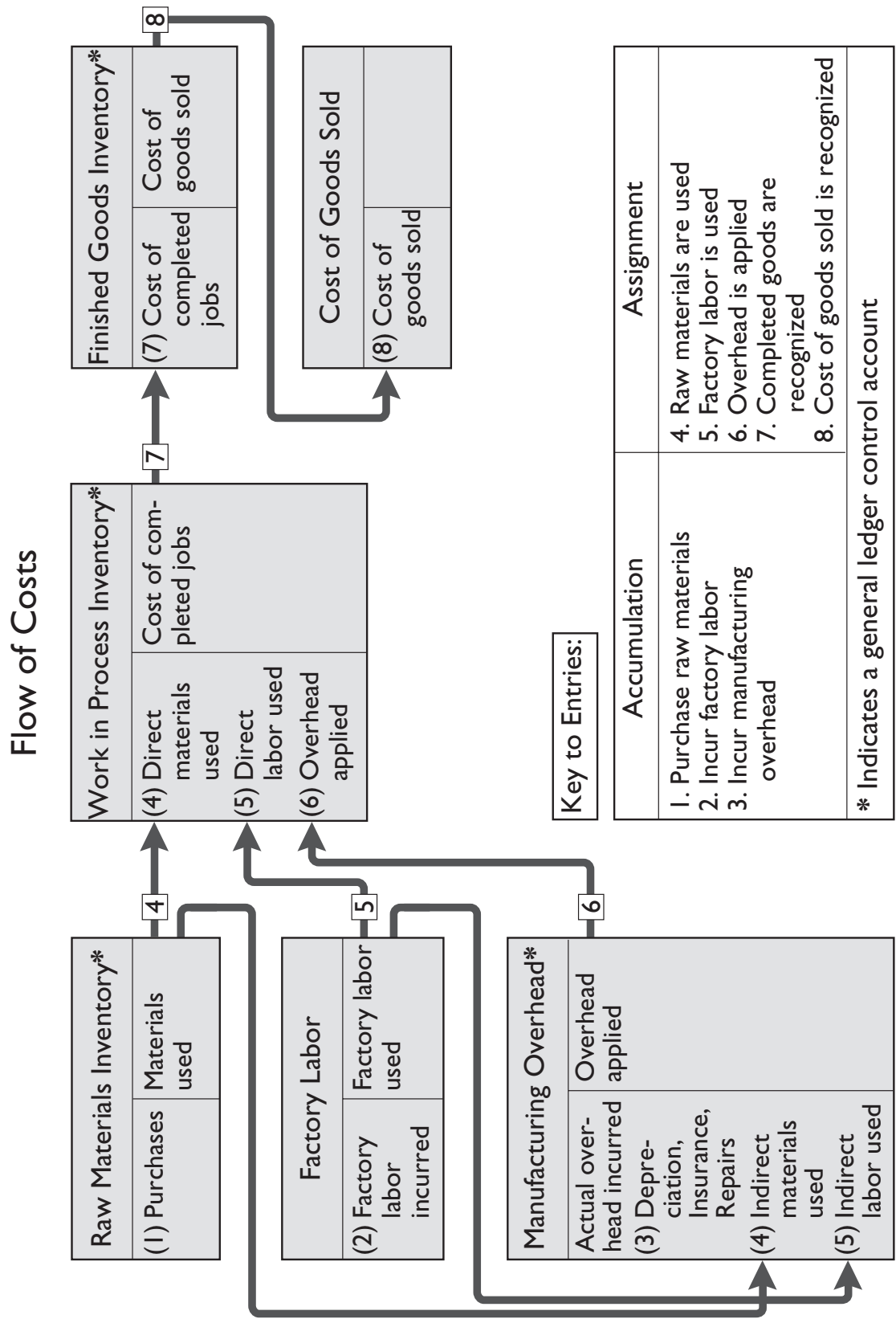

ILLUSTRATION 2-3
ACCUMULATING MANUFACTURING COST ENTRIES

1.		
Raw Materials Inventory	25,000	
Accounts Payable		25,000
(Purchase of raw materials on account)		
2.		
Factory Labor	50,000	
Factory Wages Payable		46,000
Payroll Taxes Payable		4,000
(To record factory labor costs)		
3.		
Manufacturing Overhead	20,000	
Utilities Payable, Accumulated		
Depreciation, and Prepaid Insurance		20,000
(To record overhead costs)		

**ILLUSTRATION 2-4
ASSIGNING MANUFACTURING COST TO WORK
IN PROCESS ENTRIES**

4.	Work in Process Inventory Manufacturing Overhead Raw Materials Inventory (To assign materials to jobs and overhead)	18,000 2,000	20,000
5.	Work in Process Inventory Manufacturing Overhead Factory Labor (To assign labor to jobs and overhead)	42,000 8,000	50,000
6.	Work in Process Inventory Manufacturing Overhead (To assign overhead to jobs)	21,000	21,000

Predetermined Overhead Rate				
Estimated Annual Overhead Costs	÷	Expected Annual Operating Activity	=	Predetermined Overhead Rate
\$100,000		Labor Cost \$200,000		50% of Labor Cost

ILLUSTRATION 2-5
ASSIGNING COSTS TO FINISHED GOODS AND
COST OF GOODS SOLD ENTRIES

7.		
Finished Goods Inventory	75,000	
Work in Process Inventory		75,000
(To record completion of job)		
8.		
Accounts Receivable	150,000	
Sales		150,000
(To record sale of job)		
Cost of Goods Sold	75,000	
Finished Goods Inventory		75,000
(To record cost of sale)		

ILLUSTRATION 2-6 JOB ORDER COST FLOWS

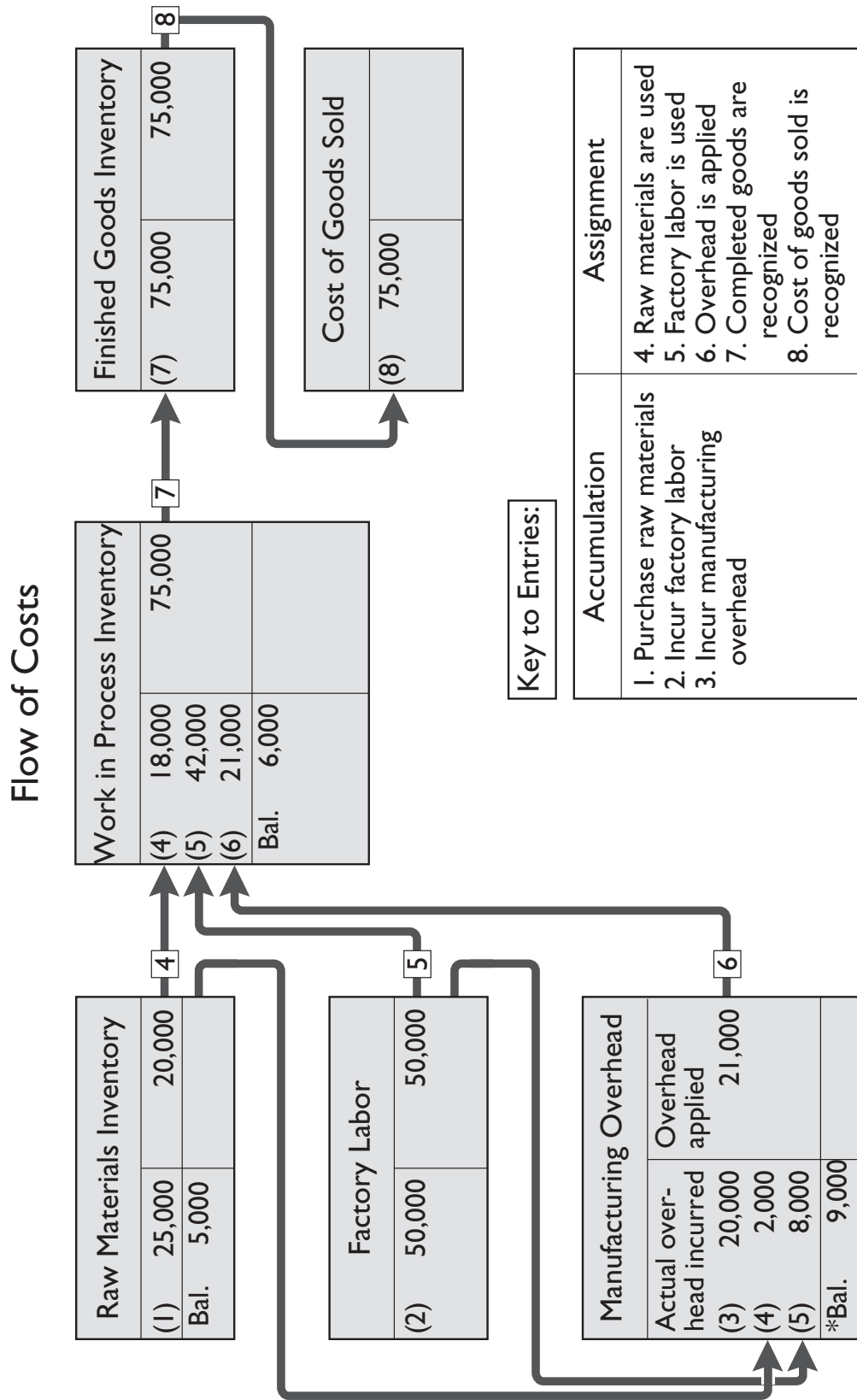

* Underapplied

ILLUSTRATION 2-7 FLOW OF DOCUMENTS—JOB COST SYSTEM

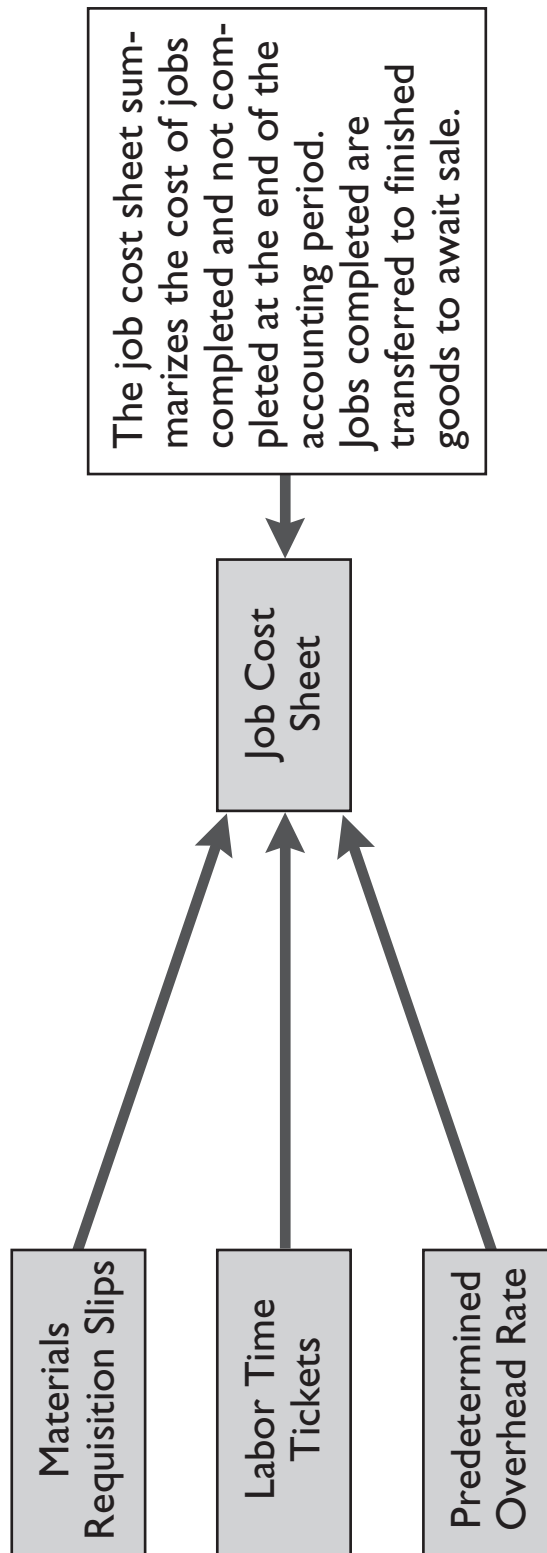

ILLUSTRATION 2-8
UNDER-AND OVERAPPLIED MANUFACTURING OVERHEAD

MANUFACTURING OVERHEAD	
Actual Costs	Applied Costs
Debit Balance — underapplied	Credit Balance — overapplied

