

SOLUTIONS MANUAL

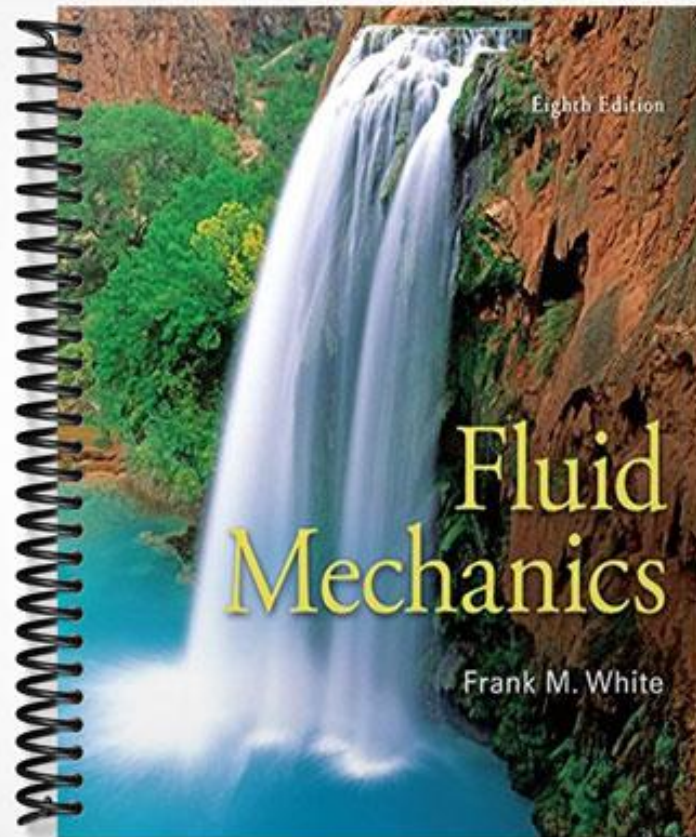

Eighth Edition

**Fluid
Mechanics**

Frank M. White

Chapter 2 • Pressure Distribution in a Fluid

P2.1 For the two-dimensional stress field in Fig. P2.1, let

$$\begin{aligned}\sigma_{xx} &= 3000 \text{ psf} & \sigma_{yy} &= 2000 \text{ psf} \\ \sigma_{xy} &= 500 \text{ psf}\end{aligned}$$

Find the shear and normal stresses on plane AA cutting through at 30° .

Solution: Make cut “AA” so that it just hits the bottom right corner of the element. This gives the freebody shown at right. Now sum forces normal and tangential to side AA. Denote side length AA as “L.”

$$\begin{aligned}\sum F_{n,AA} &= 0 = \sigma_{AA} L \\ &- (3000 \sin 30 + 500 \cos 30)L \sin 30 \\ &- (2000 \cos 30 + 500 \sin 30)L \cos 30\end{aligned}$$

Solve for $\sigma_{AA} \approx \mathbf{2683 \text{ lbf/ft}^2}$ Ans. (a)

$$\sum F_{t,AA} = 0 = \tau_{AA} L - (3000 \cos 30 - 500 \sin 30)L \sin 30 - (500 \cos 30 - 2000 \sin 30)L \cos 30$$

Solve for $\tau_{AA} \approx \mathbf{683 \text{ lbf/ft}^2}$ Ans. (b)

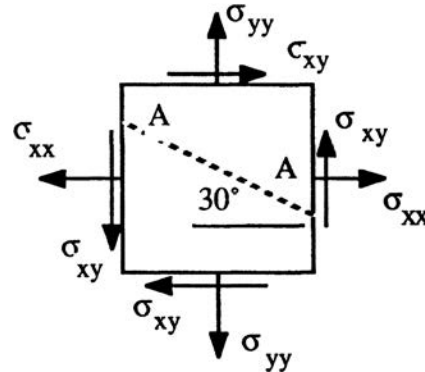
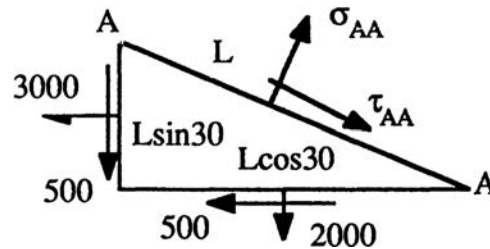

Fig. P2.1



P2.2 For the stress field of Fig. P2.1, change the known data to $\sigma_{xx} = 2000$ psf, $\sigma_{yy} = 3000$ psf, and $\sigma_n(AA) = 2500$ psf. Compute σ_{xy} and the shear stress on plane AA.

Solution: Sum forces normal to and tangential to AA in the element freebody above, with $\sigma_n(AA)$ known and σ_{xy} unknown:

$$\begin{aligned}\sum F_{n,AA} &= 2500L - (\sigma_{xy} \cos 30^\circ + 2000 \sin 30^\circ)L \sin 30^\circ \\ &- (\sigma_{xy} \sin 30^\circ + 3000 \cos 30^\circ)L \cos 30^\circ = 0 \\ \text{Solve for } \sigma_{xy} &= (2500 - 500 - 2250)/0.866 \approx \mathbf{-289 \text{ lbf/ft}^2} \text{ Ans. (a)}\end{aligned}$$

In like manner, solve for the shear stress on plane AA, using our result for σ_{xy} :

$$\begin{aligned}\sum F_{t,AA} &= \tau_{AA}L - (2000 \cos 30^\circ + 289 \sin 30^\circ)L \sin 30^\circ \\ &\quad + (289 \cos 30^\circ + 3000 \sin 30^\circ)L \cos 30^\circ = 0\end{aligned}$$

$$\text{Solve for } \tau_{AA} = 938 - 1515 \approx \mathbf{-577 \text{ lbf/ft}^2} \quad \text{Ans. (b)}$$

This problem and Prob. P2.1 can also be solved using Mohr's circle.

P2.3 A vertical clean glass piezometer tube has an inside diameter of 1 mm. When a pressure is applied, water at 20°C rises into the tube to a height of 25 cm. After correcting for surface tension, estimate the applied pressure in Pa.

Solution: For water, let $Y = 0.073 \text{ N/m}$, contact angle $\theta = 0^\circ$, and $\gamma = 9790 \text{ N/m}^3$. The capillary rise in the tube, from Example 1.9 of the text, is

$$h_{cap} = \frac{2Y \cos \theta}{\gamma R} = \frac{2(0.073 \text{ N/m}) \cos(0^\circ)}{(9790 \text{ N/m}^3)(0.0005 \text{ m})} = 0.030 \text{ m}$$

Then the rise due to applied pressure is less by that amount: $h_{press} = 0.25 \text{ m} - 0.03 \text{ m} = 0.22 \text{ m}$. The applied pressure is estimated to be $p = \gamma h_{press} = (9790 \text{ N/m}^3)(0.22 \text{ m}) \approx \mathbf{2160 \text{ Pa}}$ Ans.

P2.4 Pressure gages, such as the Bourdon gage in Fig. P2.4, are calibrated with a deadweight piston. If the Bourdon gage is designed to rotate the pointer 10 degrees for every 2 psig of internal pressure, how many degrees does the pointer rotate if the piston and weight together total 44 newtons?

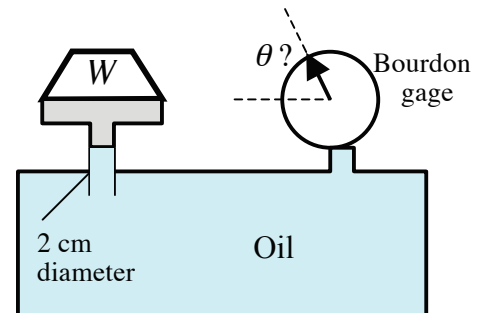

Fig. P2.4

Solution: The deadweight, divided by the piston area, should equal the pressure applied to the Bourdon gage. Stay in SI units for the moment:

$$P_{Bourdon} = \frac{F}{A_{piston}} = \frac{44 \text{ N}}{(\pi/4)(0.02 \text{ m})^2} = 140,060 \text{ Pa} \div 6894.8 = 20.3 \frac{\text{lbf}}{\text{in}^2}$$

At 10 degrees for every 2 psig, the pointer should move approximately **100 degrees**. *Ans.*

P2.5 Quito, Ecuador has an average altitude of 9,350 ft. On a standard day, pressure gage A in a laboratory experiment reads 63 kPa and gage B reads 105 kPa. Express these readings in gage pressure or vacuum pressure, whichever is appropriate.

Solution: Convert 9,350 ft \times 0.3048 = 2,850 m. We can interpolate in the Standard Altitude Table A.6 to a pressure of about 71.5 kPa. Or we could use Eq. (2.20):

$$p = p_o \left(1 - \frac{Bz}{T_o}\right)^{g/RB} = (101350) \left[1 - \frac{(0.0065)(2850)}{288.16}\right]^{5.26} = (101350)(0.70503) = 71,500 \text{ Pa}$$

Good interpolating! Then $p_A = 71500 - 63000 = \mathbf{8500 \text{ Pa}}$ (vacuum pressure) *Ans.(A)*,
and $p_B = 105000 - 71500 = \mathbf{33500 \text{ Pa}}$ (gage pressure) *Ans.(B)*

P2.6 Express standard atmospheric pressure as a head, $h = p/\rho g$, in (a) feet of glycerin; (b) inches of mercury; (c) meters of water; and (d) mm of ethanol.

Solution: Take the specific weights, $\gamma = \rho g$, from Table A.3, divide p_{atm} by γ :

(a) Glycerin: $h = (2116 \text{ lbf/ft}^2)/(78.7 \text{ lbf/ft}^3) \approx \mathbf{26.9 \text{ ft}}$ *Ans. (a)*

(b) Mercury: $h = (2116 \text{ lbf/ft}^2)/(846 \text{ lbf/ft}^3) = 2.50 \text{ ft} \approx \mathbf{30.0 \text{ inches}}$ *Ans. (b)*

(c) Water: $h = (101350 \text{ N/m}^2)/(9790 \text{ N/m}^3) \approx \mathbf{10.35 \text{ m}}$ *Ans. (c)*

(d) Ethanol: $h = (101350 \text{ N/m}^2)/(7740 \text{ N/m}^3) = 13.1 \text{ m} \approx \mathbf{13100 \text{ mm}}$ *Ans. (d)*

P2.7 La Paz, Bolivia is at an altitude of approximately 12,000 ft. Assume a standard atmosphere. How high would the liquid rise in a *methanol* barometer, assumed at 20°C? [HINT: Don't forget the vapor pressure.]

Solution: Convert 12,000 ft to 3658 meters, and Table A.6, or Eq. (2.20), give

$$p_{LaPaz} = p_o \left(1 - \frac{Bz}{T_o}\right)^{g/(RB)} = 101350 \left[1 - \frac{(0.0065)(3658)}{288.16}\right]^{5.26} \approx 64,400 \text{ Pa}$$

From Table A.3, methanol has $\rho = 791 \text{ kg/m}^3$ and a large vapor pressure of 13,400 Pa. Then the manometer rise h is given by

$$p_{\text{LaPaz}} - p_{\text{vap}} = 64400 - 13400 = \rho_{\text{methanol}} g h = (791)(9.81)h$$

$$\text{Solve for } h_{\text{methanol}} = \mathbf{6.57 \text{ m}} \quad \text{Ans}$$

P2.8 Suppose, which is possible, that there is a half-mile deep lake of pure ethanol on the surface of Mars. Estimate the absolute pressure, in Pa, at the bottom of this speculative lake.

Solution: We need some data from the Internet: Mars gravity is 3.71 m/s^2 , surface pressure is 700 Pa, and surface temperature is -10°F (above the freezing temperature of ethanol). Then the bottom pressure is given by the hydrostatic formula, with ethanol density equal to 789 kg/m^3 from Table A.3. Convert $\frac{1}{2} \text{ mile} = \frac{1}{2}(5280) \text{ ft} = 2640 \text{ ft} * 0.3048 \text{ m/ft} = 804.7 \text{ m}$. Then

$$p_{\text{bottom}} \approx p_{\text{surface}} + \rho g h = 700 + (789)(3.71)(804.7 \text{ m}) = 700 + 2,356,000 = \mathbf{2.36E6 \text{ Pa}} \quad \text{Ans.}$$

P2.9 A storage tank, 26 ft in diameter and 36 ft high, is filled with SAE 30W oil at 20°C . (a) What is the gage pressure, in lbf/in^2 , at the bottom of the tank? (b) How does your result in (a) change if the tank diameter is reduced to 15 ft? (c) Repeat (a) if leakage has caused a layer of 5 ft of water to rest at the bottom of the (full) tank.

Solution: This is a straightforward problem in hydrostatic pressure. From Table A.3, the density of SAE 30W oil is $891 \text{ kg/m}^3 \div 515.38 = 1.73 \text{ slug/ft}^3$. (a) Thus the bottom pressure is

$$p_{\text{bottom}} = \rho_{\text{oil}} g h = (1.73 \frac{\text{slug}}{\text{ft}^3})(32.2 \frac{\text{ft}}{\text{s}^2})(36 \text{ ft}) = 2005 \frac{\text{lbf}}{\text{ft}^2} = \mathbf{13.9 \frac{\text{lbf}}{\text{in}^2} \text{ gage}} \quad \text{Ans.(a)}$$

(b) The tank diameter has nothing to do with it, just the depth: $p_{\text{bottom}} = \mathbf{13.9 \text{ psig}}$. *Ans.(b)*

(c) If we have 31 ft of oil and 5 ft of water ($\rho = 1.94 \text{ slug/ft}^3$), the bottom pressure is

$$\begin{aligned}
 p_b &= \rho_{oil} g h_{oil} + \rho_{water} g h_{water} = (1.73)(32.2)(31) + (1.94)(32.2)(5) = \\
 &= 1727 + 312 = 2039 \frac{lb_f}{ft^2} = 14.2 \frac{lb_f}{in^2} \quad Ans.(c)
 \end{aligned}$$

P2.10 A large open tank is open to sea level atmosphere and filled with liquid, at 20°C, to a depth of 50 ft. The absolute pressure at the bottom of the tank is approximately 221.5 kPa. From Table A.3, what might this liquid be?

Solution: Convert 50 ft to 15.24 m. Use the hydrostatic formula to calculate the bottom pressure:

$$P_{bottom} = p_a + \rho g H = [101,350 Pa + \rho(9.81)(15.24)] = 221,500 Pa$$

Solve for $\rho \approx 804 \text{ kg/m}^3$. Table A.3: It might be **kerosene**. *Ans*

P2.11 In Fig. P2.11, sensor A reads 1.5 kPa (gage). All fluids are at 20°C. Determine the elevations Z in meters of the liquid levels in the open piezometer tubes B and C.

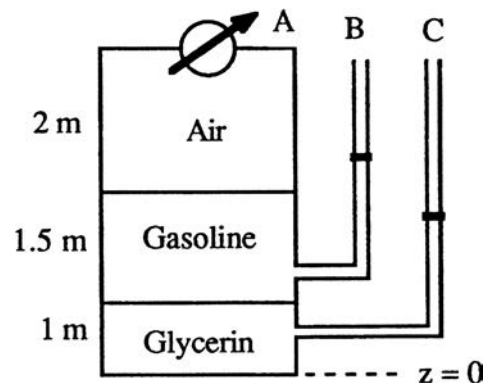

Fig. P2.11

Solution: (B) Let piezometer tube B be an arbitrary distance H above the gasoline-glycerin interface. The specific weights are $\gamma_{air} \approx 12.0 \text{ N/m}^3$, $\gamma_{gasoline} = 6670 \text{ N/m}^3$, and $\gamma_{glycerin} = 12360 \text{ N/m}^3$. Then apply the hydrostatic formula from point A to point B:

$$1500 \text{ N/m}^2 + (12.0 \text{ N/m}^3)(2.0 \text{ m}) + 6670(1.5 - H) - 6670(Z_B - H - 1.0) = p_B = 0 \text{ (gage)}$$

Solve for $Z_B = 2.73 \text{ m}$ (23 cm above the gasoline-air interface) *Ans. (b)*

Solution (C): Let piezometer tube C be an arbitrary distance Y above the bottom. Then

$$1500 + 12.0(2.0) + 6670(1.5) + 12360(1.0 - Y) - 12360(Z_C - Y) = p_C = 0 \text{ (gage)}$$

Solve for $Z_C = 1.93 \text{ m}$ (93 cm above the gasoline-glycerin interface) *Ans. (c)*

P2.12 In Fig. P2.12 the tank contains water and immiscible oil at 20°C. What is h in centimeters if the density of the oil is 898 kg/m^3 ?

Solution: For water take the density = 998 kg/m^3 . Apply the hydrostatic relation from the oil surface to the water surface, skipping the 8-cm part:

$$p_{\text{atm}} + (898)(g)(h + 0.12) - (998)(g)(0.06 + 0.12) = p_{\text{atm}}$$

Solve for $h \approx 0.08 \text{ m} \approx \mathbf{8.0 \text{ cm}}$ Ans.

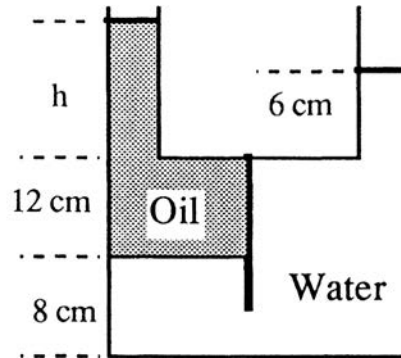

Fig. P2.12

P2.13 In Fig. P2.13 the 20°C water and gasoline are open to the atmosphere and are at the same elevation. What is the height h in the third liquid?

Solution: Take water = 9790 N/m^3 and gasoline = 6670 N/m^3 . The bottom pressure must be the same whether we move down through the water or through the gasoline into the third fluid:

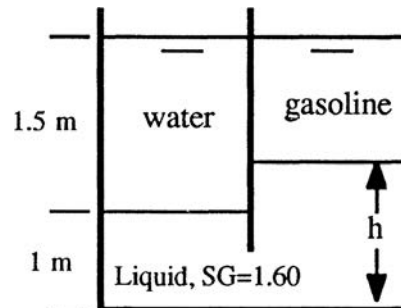

Fig. P2.13

$$p_{\text{bottom}} = (9790 \text{ N/m}^3)(1.5 \text{ m}) + 1.60(9790)(1.0) = 1.60(9790)h + 6670(2.5 - h)$$

Solve for $h = \mathbf{1.52 \text{ m}}$ Ans.

P2.14 For the three-liquid system

shown, compute h_1 and h_2 .

Neglect the air density.

Fig. P2.14

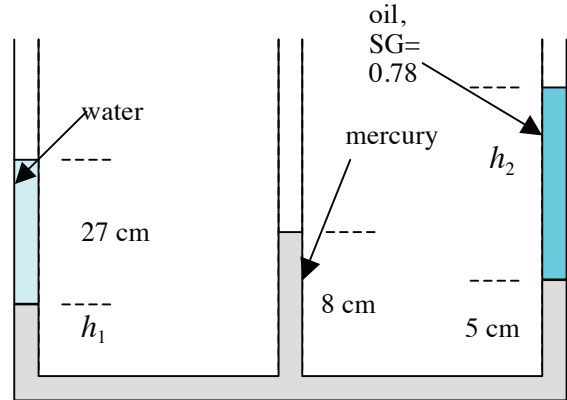

Solution: The pressures at

the three top surfaces must all be

atmospheric, or zero gage pressure. Compute $\gamma_{oil} = (0.78)(9790) = 7636 \text{ N/m}^3$. Also, from Table 2.1, $\gamma_{water} = 9790 \text{ N/m}^3$ and $\gamma_{mercury} = 133100 \text{ N/m}^3$. The surface pressure equality is

$$(9790 \frac{N}{m^3})(0.27 m) + (133100 \frac{N}{m^3})h_1 = (133100 \frac{N}{m^3})(0.08 m) = (7636 \frac{N}{m^3})h_2 + (133100 \frac{N}{m^3})(0.05 m)$$

$$\text{or: } 2643 + 133100 h_1 = 10648 Pa = 7836 h_2 + 6655$$

$$\text{Solve for } h_1 = 0.060 m = \mathbf{6.0 \text{ cm}}, \quad h_2 = 0.523 m = \mathbf{52.3 \text{ cm}} \quad \text{Ans.}$$

P2.15 In Fig. P2.15 all fluids are at 20°C. Gage A reads 15 lbf/in² absolute and gage B reads 1.25 lbf/in² less than gage C. Compute (a) the specific weight of the oil; and (b) the actual reading of gage C in lbf/in² absolute.

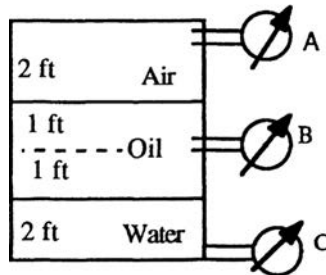

Fig. P2.15

Solution: First evaluate $\gamma_{air} = (p_A/RT)g = [15 \times 144 / (1717 \times 528)](32.2) \approx 0.0767 \text{ lbf/ft}^3$. Take $\gamma_{water} = 62.4 \text{ lbf/ft}^3$. Then apply the hydrostatic formula from point B to point C:

$$p_B + \gamma_{oil}(1.0 \text{ ft}) + (62.4)(2.0 \text{ ft}) = p_C = p_B + (1.25)(144) \text{ psf}$$

$$\text{Solve for } \gamma_{\text{oil}} \approx \mathbf{55.2 \text{ lbf/ft}^3} \quad \text{Ans. (a)}$$

With the oil weight known, we can now apply hydrostatics from point A to point C:

$$p_C = p_A + \sum \rho g h = (15)(144) + (0.0767)(2.0) + (55.2)(2.0) + (62.4)(2.0)$$

$$\text{or: } p_C = 2395 \text{ lbf/ft}^2 = \mathbf{16.6 \text{ psi}} \quad \text{Ans. (b)}$$

P2.16 If the absolute pressure at the interface

between water and mercury in Fig. P2.16 is 93 kPa,

what, in lbf/ft^2 , is (a) the pressure at the surface, and (b) the pressure at the bottom of the container?

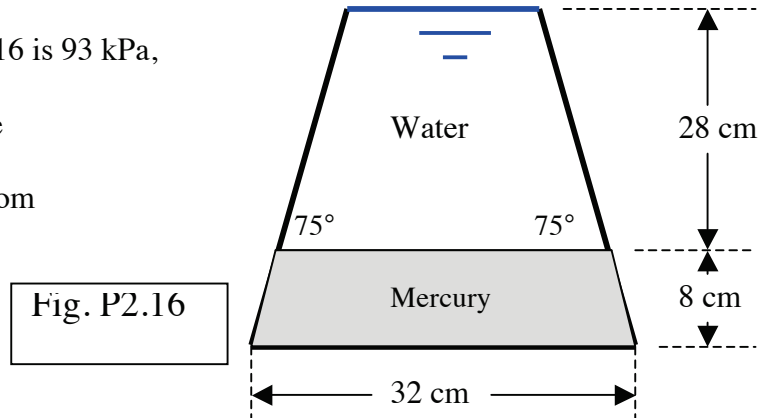

Solution: Do the whole problem in SI units and then convert to BG at the end. The bottom width and the slanted 75-degree walls are irrelevant red herrings. Just go up and down:

$$\begin{aligned} p_{\text{surface}} &= p_{\text{interface}} - \gamma_{\text{water}} \Delta h = 93000 \text{ Pa} - (9790 \text{ N/m}^3)(0.28 \text{ m}) = \\ &= 90260 \text{ Pa} \div 47.88 = \mathbf{1885 \text{ lbf/ft}^2} \quad \text{Ans (a)} \end{aligned}$$

$$\begin{aligned} p_{\text{bottom}} &= p_{\text{interface}} + \gamma_{\text{mercury}} \Delta h = 93000 \text{ Pa} + (133100 \text{ N/m}^3)(0.08 \text{ m}) = \\ &= 103650 \text{ Pa} \div 47.88 = \mathbf{2165 \text{ lbf/ft}^2} \quad \text{Ans (b)} \end{aligned}$$

P2.17 The system in Fig. P2.17 is at 20°C.

Determine the height h of the water in the left side.

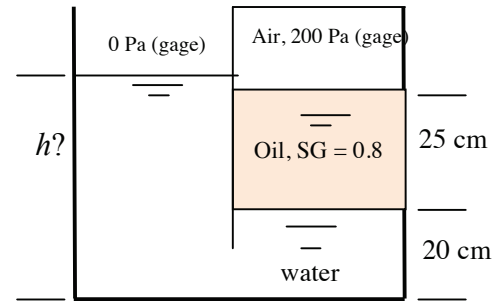

Solution: The bottom pressure must be the same from both left and right viewpoints:

$$p_{b, \text{left}} = 9790 h = p_{b, \text{right}} = 200 + [0.8(9790)(0.25)] + (9790)(0.2) = 200 + 1958 + 1958 = 4116 \text{ Pa}$$

$$\text{Solve for } h = 4116 / 9790 = 0.42 \text{ m} = \mathbf{42 \text{ cm}} \quad \text{Ans}$$

P2.18 All fluids in Fig. P2.18 are at 20°C. If atmospheric pressure = 101.33 kPa and the bottom pressure is 242 kPa absolute, what is the specific gravity of fluid X?

Solution: Simply apply the hydrostatic formula from top to bottom:

$$p_{\text{bottom}} = p_{\text{top}} + \sum \gamma h,$$

$$\text{or: } 242000 = 101330 + (8720)(1.0) + (9790)(2.0) + \gamma_X(3.0) + (133100)(0.5)$$

$$\text{Solve for } \gamma_X = 15273 \text{ N/m}^3, \quad \text{or: } \text{SG}_X = 15273 / 9790 = \mathbf{1.56} \quad \text{Ans.}$$

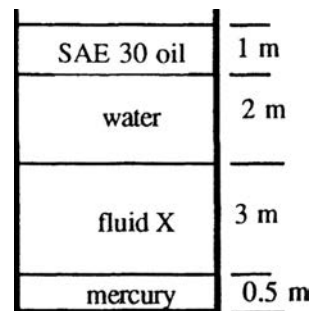
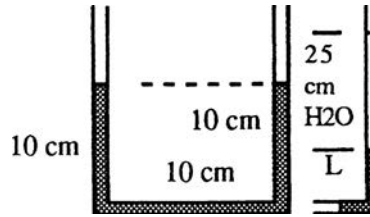

Fig. P2.18

P2.19 The U-tube at right has a 1-cm ID and contains mercury as shown. If 20 cm^3 of water is poured into the right-hand leg, what will be the free surface height in each leg after the sloshing has died down?



Solution: First figure the height of water added:

$$20 \text{ cm}^3 = \frac{\pi}{4}(1 \text{ cm})^2 h, \quad \text{or} \quad h = 25.46 \text{ cm}$$

Then, at equilibrium, the new system must have 25.46 cm of water on the right, and a 30-cm length of mercury is somewhat displaced so that “L” is on the right, 0.1 m on the bottom, and “0.2 – L” on the left side, as shown at right. The bottom pressure is constant:

$$p_{\text{atm}} + 133100(0.2 - L) = p_{\text{atm}} + 9790(0.2546) + 133100(L), \quad \text{or:} \quad L \approx 0.0906 \text{ m}$$

$$\text{Thus right-leg-height} = 9.06 + 25.46 = \mathbf{34.52 \text{ cm} \text{ Ans.}}$$

$$\text{left-leg-height} = 20.0 - 9.06 = \mathbf{10.94 \text{ cm} \text{ Ans.}}$$

P2.20 The hydraulic jack in Fig. P2.20 is filled with oil at 56 lbf/ft^3 . Neglecting piston weights, what force F on the handle is required to support the 2000-lbf weight shown?

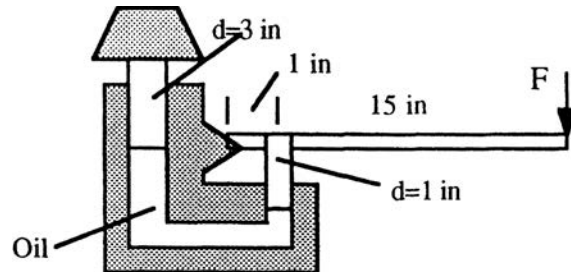

Fig. P2.20

Solution: First sum moments clockwise about the hinge A of the handle:

$$\sum M_A = 0 = F(15 + 1) - P(1),$$

$$\text{or: } F = P/16, \text{ where } P \text{ is the force in the small (1 in) piston.}$$

Meanwhile figure the pressure in the oil from the weight on the large piston:

$$p_{\text{oil}} = \frac{W}{A_{3\text{-in}}} = \frac{2000 \text{ lbf}}{(\pi/4)(3/12 \text{ ft})^2} = 40744 \text{ psf,}$$

$$\text{Hence } P = p_{\text{oil}} A_{\text{small}} = (40744) \frac{\pi}{4} \left(\frac{1}{12} \right)^2 = 222 \text{ lbf}$$

Therefore the handle force required is $F = P/16 = 222/16 \approx \mathbf{14 \text{ lbf}}$ *Ans.*

P2.21 In Fig. P2.21 all fluids are at 20°C. Gage A reads 350 kPa absolute. Determine (a) the height h in cm; and (b) the reading of gage B in kPa absolute.

Solution: Apply the hydrostatic formula from the air to gage A:

$$\begin{aligned} p_A &= p_{\text{air}} + \sum \gamma h \\ &= 180000 + (9790)h + 133100(0.8) = 350000 \text{ Pa,} \end{aligned}$$

$$\text{Solve for } h \approx \mathbf{6.49 \text{ m}} \text{ } \textit{Ans. (a)}$$

Then, with h known, we can evaluate the pressure at gage B:

$$p_B = 180000 + 9790(6.49 + 0.80) = 251000 \text{ Pa} \approx \mathbf{251 \text{ kPa}} \text{ } \textit{Ans. (b)}$$

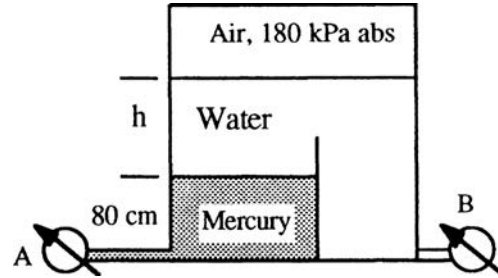

Fig. P2.21

P2.22 The fuel gage for an auto gas tank reads proportional to the bottom gage pressure as in Fig. P2.22. If the tank accidentally contains 2 cm of water plus gasoline, how many centimeters “ h ” of air remain when the gage reads “full” in error?

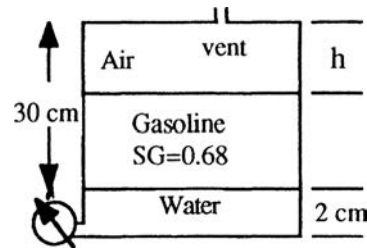

Fig. P2.22

Solution: Given $\gamma_{\text{gasoline}} = 0.68(9790) = 6657 \text{ N/m}^3$, compute the gage pressure when “full”:

$$p_{\text{full}} = \gamma_{\text{gasoline}} (\text{full height}) = (6657 \text{ N/m}^3)(0.30 \text{ m}) = 1997 \text{ Pa}$$

Set this pressure equal to 2 cm of water plus “ Y ” centimeters of gasoline:

$$p_{\text{full}} = 1997 = 9790(0.02 \text{ m}) + 6657Y, \text{ or } Y \approx 0.2706 \text{ m} = 27.06 \text{ cm}$$

Therefore the air gap $h = 30 \text{ cm} - 2 \text{ cm}(\text{water}) - 27.06 \text{ cm}(\text{gasoline}) \approx \mathbf{0.94 \text{ cm}}$ *Ans.*

P2.23 In Fig. P2.23 both fluids are at 20°C. If surface tension effects are negligible, what is the density of the oil, in kg/m³?

Solution: Move around the U-tube from left atmosphere to right atmosphere:

$$\begin{aligned} p_a + (9790 \text{ N/m}^3)(0.06 \text{ m}) \\ - \gamma_{\text{oil}}(0.08 \text{ m}) &= p_a, \\ \text{solve for } \gamma_{\text{oil}} &\approx 7343 \text{ N/m}^3, \end{aligned}$$

$$\text{or: } \rho_{\text{oil}} = 7343/9.81 \approx \mathbf{748 \text{ kg/m}^3} \quad \text{Ans.}$$

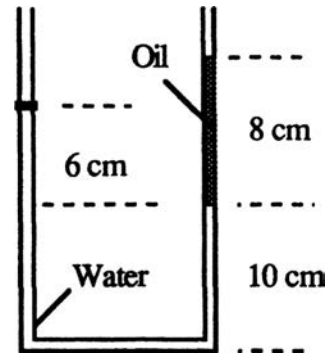

Fig. P2.23

P2.24 In Prob. 1.2 we made a crude integration of atmospheric density from Table A.6 and found that the atmospheric mass is approximately $m \approx 6\text{E}18$ kg. Can this result be used to estimate sea-level pressure? Can sea-level pressure be used to estimate m ?

Solution: Yes, atmospheric pressure is essentially a result of the weight of the air above. Therefore the air weight divided by the surface area of the earth equals sea-level pressure:

$$p_{\text{sea-level}} = \frac{W_{\text{air}}}{A_{\text{earth}}} = \frac{m_{\text{air}}g}{4\pi R_{\text{earth}}^2} \approx \frac{(6.0\text{E}18 \text{ kg})(9.81 \text{ m/s}^2)}{4\pi(6.377\text{E}6 \text{ m})^2} \approx \mathbf{115000 \text{ Pa}} \quad \text{Ans.}$$

This is a little off, thus our mass estimate must have been a little off. If global average sea-level pressure is actually 101350 Pa, then the mass of atmospheric air must be more nearly

$$m_{\text{air}} = \frac{A_{\text{earth}} p_{\text{sea-level}}}{g} \approx \frac{4\pi(6.377\text{E}6 \text{ m})^2(101350 \text{ Pa})}{9.81 \text{ m/s}^2} \approx \mathbf{5.28\text{E}18 \text{ kg}} \quad \text{Ans.}$$

***P2.25** As measured by NASA's Viking landers, the atmosphere of Mars, where $g = 3.71 \text{ m/s}^2$, is almost entirely carbon dioxide, and the surface pressure averages 700 Pa. The temperature is cold and drops off exponentially: $T \approx T_o e^{-Cz}$, where $C \approx 1.3E-5 \text{ m}^{-1}$ and $T_o \approx 250 \text{ K}$. For example, at 20,000 m altitude, $T \approx 193 \text{ K}$. (a) Find an analytic formula for the variation of pressure with altitude. (b) Find the altitude where pressure on Mars has dropped to 1 pascal.

Solution: (a) The analytic formula is found by integrating Eq. (2.17) of the text:

$$\ln\left(\frac{p}{p_o}\right) = -\frac{g}{R} \int_0^z \frac{dz}{T} = -\frac{g}{R} \int_0^z \frac{dz}{T_o e^{-Cz}} = -\frac{g}{RT_o C} (e^{Cz} - 1)$$

or, finally, $p = p_o \exp\left[-\frac{g}{RT_o C} (e^{Cz} - 1)\right]$ Ans.(a)

(b) From Table A.4 for CO_2 , $R = 189 \text{ m}^2/(\text{s}^2\text{-K})$. Substitute $p = 1 \text{ Pa}$ to find the altitude:

$$p = 1 \text{ Pa} = p_o \exp\left[-\frac{g}{RT_o C} (e^{Cz} - 1)\right] = (700 \text{ Pa}) \exp\left[-\frac{3.71 \text{ m/s}^2}{(189)(250)(1.3E-5)} \{e^{(1.3E-5)z} - 1\}\right]$$

or: $\ln\left(\frac{1}{700}\right) = -6.55 = -6.04 \{e^{(1.3E-5)z} - 1\}$, Solve for $z \approx \mathbf{56,500 \text{ m}}$ Ans.(b)

P2.26 For gases over large changes in height, the linear approximation, Eq. (2.14), is inaccurate. Expand the troposphere power-law, Eq. (2.20), into a power series and show that the linear approximation $p \approx p_a - \rho_a g z$ is adequate when

$$\delta z \ll \frac{2T_o}{(n-1)B}, \quad \text{where } n = \frac{g}{RB}$$

$$\left(1 - \frac{Bz}{T_o}\right)^n = 1 - n\frac{Bz}{T_o} + \frac{n(n-1)}{2!} \left(\frac{Bz}{T_o}\right)^2 - \dots \quad \text{where } n = \frac{g}{RB}$$

Solution: The power-law term in Eq. (2.20) can be expanded into a series:

Multiply by p_a , as in Eq. (2.20), and note that $p_a n B / T_o = (p_a / RT_o) g z = \rho_a g z$. Then the series may be rewritten as follows:

$$p = p_a - \rho_a g z \left(1 - \frac{n-1}{2} \frac{Bz}{T_o} + \dots\right)$$

For the linear law to be accurate, the 2nd term in parentheses must be much less than unity. If the starting point is not at $z = 0$, then replace z by δz :

$$\frac{n-1}{2} \frac{B \delta z}{T_o} \ll 1, \quad \text{or:} \quad \delta z \ll \frac{2T_o}{(n-1)B} \quad \text{Ans.}$$

P2.27 This is an *experimental* problem: Put a card or thick sheet over a glass of water, hold it tight, and turn it over without leaking (a glossy postcard works best). Let go of the card. Will the card stay attached when the glass is upside down? **Yes:** This is essentially a *water barometer* and, in principle, could hold a column of water up to 10 ft high!

P2.28 A correlation of computational fluid dynamics results indicates that, all other things being equal, the distance traveled by a well-hit baseball varies inversely as the 0.36 power of the air density. If a home-run ball hit in NY Mets Citi Field Stadium travels 400 ft, estimate the distance it would travel in (a) Quito, Ecuador, and (b) Colorado Springs, CO.

Solution: Citi Field is in the Borough of Queens, NY, essentially at sea level. Hence the standard pressure is $p_o \approx 101,350$ Pa. Look up the altitude of the other two cities and calculate the pressure:

$$(a) \text{ Quito: } z \approx 2850 \text{ m, } p_Q = p_o \left[1 - \frac{(0.0065)(2850)}{288.16} \right]^{5.26} = (101350)(0.705) = 71,500 \text{ Pa}$$

$$(b) \text{ Colorado Springs: } z \approx 1835 \text{ m, } p_{CC} = p_o \left[1 - \frac{(0.0065)(1835)}{288.16} \right]^{5.26} = (101350)(0.801) = 81,100 \text{ Pa}$$

Then the estimated home-run distances are:

$$(a) \text{ Quito: } X = 400 \left(\frac{101350}{71500} \right)^{0.36} = 400(1.134) \approx \mathbf{454 \text{ ft}} \quad \text{Ans.}(a)$$

$$(b) \text{ Colorado Springs: } X = 400 \left(\frac{101350}{81100} \right)^{0.36} = 400(1.084) \approx \mathbf{433 \text{ ft}} \quad \text{Ans.}(b)$$

The Colorado result is often confirmed by people who attend Rockies baseball games.

P2.29 Follow up on Prob. P2.8 by estimating the altitude on Mars where the pressure has dropped to 20% of its surface value. Assume an *isothermal* atmosphere, not the exponential variation of P2.25.

Solution: Problem P2.8 we used a surface temperature $T_o = -10^\circ\text{F} = -23^\circ\text{C} = 250\text{ K}$. Recall that $g_{\text{Mars}} \approx 3.71\text{ m/s}^2$. Mars atmosphere is primarily CO_2 , hence $R_{\text{Mars}} \approx 189\text{ m}^2/\text{s}^2\cdot\text{K}$ from Table A.4. Equation (2.18), for an isothermal atmosphere, thus predicts

$$\frac{p}{p_a} = 0.2 = \exp\left[-\frac{g(z_2 - z_1)}{RT_o}\right] = \exp\left[-\frac{(3.71)(z - 0)}{(189)(250)}\right]; \text{ solve for } z \approx \mathbf{20,500\text{ m}} \quad \text{Ans.}$$

P2.30 For the traditional equal-level manometer measurement in Fig. E2.3, water at 20°C flows through the plug device from a to b . The manometer fluid is mercury. If $L = 12\text{ cm}$ and $h = 24\text{ cm}$, (a) what is the pressure drop through the device? (b) If the water flows through the pipe at a velocity $V = 18\text{ ft/s}$, what is the *dimensionless loss coefficient* of the device, defined by $K = \Delta p/(\rho V^2)$? We will study loss coefficients in Chap. 6.

Solution: Gather density data: $\rho_{\text{mercury}} = 13550\text{ kg/m}^3$, $\rho_{\text{water}} = 998\text{ kg/m}^3$. Example 2.3, by going down from (a) to the mercury level, jumping across, and going up to (b), found the very important formula for this type of equal-leg manometer:

$$\Delta p = p_a - p_b = (\rho_{\text{merc}} - \rho_{\text{water}})gh = (13550 - 998\text{ kg/m}^3)(9.81\text{ m/s}^2)(0.24\text{ m})$$

or: $\Delta p = \mathbf{29,600\text{ Pa}} \quad \text{Ans.(a)}$

(b) The loss coefficient calculation is straightforward, but we check the units to make sure. Convert the velocity from 18 ft/s to 5.49 m/s . Then

$$K = \frac{\Delta p}{\rho V^2} = \frac{29600\text{ N/m}^2}{(998\text{ kg/m}^3)(5.49\text{ m/s})^2} = \frac{29600\text{ N/m}^2}{30080\text{ N/m}^2} = \mathbf{0.98} \quad \text{Ans.(b)}$$

P2.31 In Fig. P2.31 determine Δp between points A and B. All fluids are at 20°C .

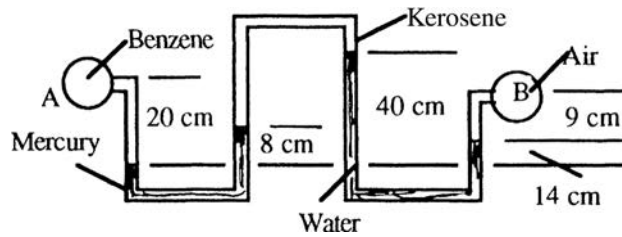

Fig. P2.31

Solution: Take the specific weights to be

$$\text{Benzene: } 8640 \text{ N/m}^3 \quad \text{Mercury: } 133100 \text{ N/m}^3$$

$$\text{Kerosene: } 7885 \text{ N/m}^3 \quad \text{Water: } 9790 \text{ N/m}^3$$

and γ_{air} will be small, probably around 12 N/m^3 . Work your way around from A to B:

$$\begin{aligned} p_A + (8640)(0.20 \text{ m}) - (133100)(0.08) - (7885)(0.32) + (9790)(0.26) - (12)(0.09) \\ = p_B, \quad \text{or, after cleaning up, } p_A - p_B \approx \mathbf{8900 \text{ Pa}} \quad \text{Ans.} \end{aligned}$$

P2.32 For the manometer of Fig. P2.32, all fluids are at 20°C . If $p_B - p_A = 97 \text{ kPa}$, determine the height H in centimeters.

Solution: $\gamma = 9790 \text{ N/m}^3$ for water and 133100 N/m^3 for mercury and $(0.827)(9790) = 8096 \text{ N/m}^3$ for Meriam red oil. Work your way around from point A to point B:

$$\begin{aligned} p_A - (9790 \text{ N/m}^3)(H \text{ meters}) - 8096(0.18) + \\ + 133100(0.18 + H + 0.35) = p_B = p_A + 97000. \end{aligned}$$

$$\text{Solve for } H \approx 0.226 \text{ m} = \mathbf{22.6 \text{ cm}} \quad \text{Ans.}$$

Meriam red oil, $\text{SG} = 0.827$

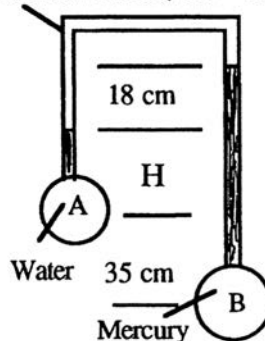

Fig. P2.32

P2.33 In Fig. P2.33 the pressure at point A is 25 psi. All fluids are at 20°C. What is the air pressure in the closed chamber B?

Solution: Take $\gamma = 9790 \text{ N/m}^3$ for water, 8720 N/m^3 for SAE 30 oil, and $(1.45)(9790) = 14196 \text{ N/m}^3$ for the third fluid. Convert the pressure at A from 25 lbf/in^2 to 172400 Pa . Compute hydrostatically from point A to point B:

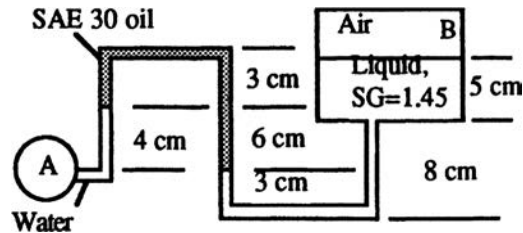

Fig. P2.33

$$p_A + \sum \gamma h = 172400 - (9790 \text{ N/m}^3)(0.04 \text{ m}) + (8720)(0.06) - (14196)(0.10)$$

$$= p_B = 171100 \text{ Pa} \div 47.88 \div 144 = \mathbf{24.8 \text{ psi}} \quad \text{Ans.}$$

P2.34 To show the effect of manometer dimensions, consider Fig. P2.34. The containers (a) and (b) are cylindrical and are such that $p_a = p_b$ as shown. Suppose the oil-water interface on the right moves up a distance $\Delta h < h$. Derive a formula for the difference $p_a - p_b$ when (a) $d \ll D$; and (b) $d = 0.15D$. What is the % difference?

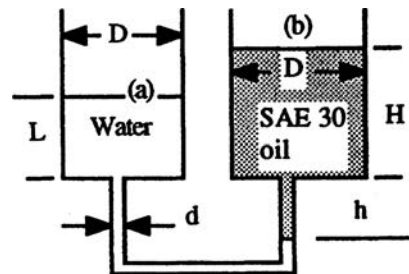

Fig. P2.34

Solution: Take $\gamma = 9790 \text{ N/m}^3$ for water and 8720 N/m^3 for SAE 30 oil. Let “H” be the height of the oil in reservoir (b). For the condition shown, $p_a = p_b$, therefore

$$\gamma_{\text{water}}(L + h) = \gamma_{\text{oil}}(H + h), \quad \text{or:} \quad H = (\gamma_{\text{water}}/\gamma_{\text{oil}})(L + h) - h \quad (1)$$

Case (a), $d \ll D$: When the meniscus rises Δh , there will be no significant change in reservoir levels. Therefore we can write a simple hydrostatic relation from (a) to (b):

$$p_a + \gamma_{\text{water}}(L + h - \Delta h) - \gamma_{\text{oil}}(H + h - \Delta h) = p_b,$$

$$\text{or:} \quad \mathbf{p_a - p_b = \Delta h(\gamma_{\text{water}} - \gamma_{\text{oil}})} \quad \text{Ans. (a)}$$

where we have used Eq. (1) above to eliminate H and L . Putting in numbers to compare later with part (b), we have $\Delta p = \Delta h(9790 - 8720) = 1070 \Delta h$, with Δh in meters.

Case (b), $d = 0.15D$. Here we must account for reservoir volume changes. For a rise $\Delta h < h$, a volume $(\pi/4)d^2\Delta h$ of water leaves reservoir (a), decreasing “ L ” by $\Delta h(d/D)^2$, and an identical volume of oil enters reservoir (b), increasing “ H ” by the same amount $\Delta h(d/D)^2$. The hydrostatic relation between (a) and (b) becomes, for this case,

$$p_a + \gamma_{\text{water}}[L - \Delta h(d/D)^2 + h - \Delta h] - \gamma_{\text{oil}}[H + \Delta h(d/D)^2 + h - \Delta h] = p_b,$$

$$\text{or: } p_a - p_b = \Delta h[\gamma_{\text{water}}(1 + d^2/D^2) - \gamma_{\text{oil}}(1 - d^2/D^2)] \quad \text{Ans. (b)}$$

where again we have used Eq. (1) to eliminate H and L . If d is not small, this is a *considerable* difference, with surprisingly large error. For the case $d = 0.15 D$, with water and oil, we obtain $\Delta p = \Delta h[1.0225(9790) - 0.9775(8720)] \approx 1486 \Delta h$ or **39% more** than (a).

P2.35 Water flows upward in a pipe slanted at 30° , as in Fig. P2.35. The mercury manometer reads $h = 12$ cm. What is the pressure difference between points (1) and (2) in the pipe?

Solution: The vertical distance between points 1 and 2 equals $(2.0 \text{ m})\tan 30^\circ$ or 1.155 m. Go around the U-tube hydrostatically from point 1 to point 2:

$$p_1 + 9790h - 133100h - 9790(1.155 \text{ m}) = p_2,$$

$$\text{or: } p_1 - p_2 = (133100 - 9790)(0.12) + 11300 = \mathbf{26100 \text{ Pa}} \quad \text{Ans.}$$

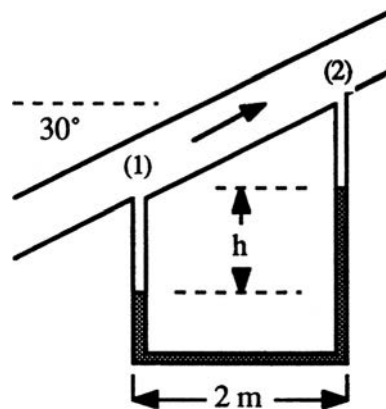

Fig. P2.35

P2.36 In Fig. P2.36 both the tank and the slanted tube are open to the atmosphere. If $L = 2.13$ m, what is the angle of tilt ϕ of the tube?

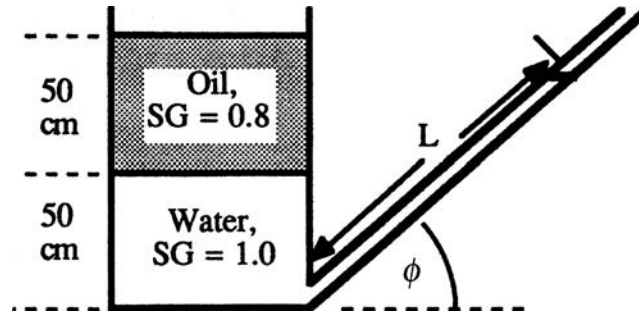

Fig. P2.36

Solution: Proceed hydrostatically from the oil surface to the slanted tube surface:

$$p_a + 0.8(9790)(0.5) + 9790(0.5) - 9790(2.13 \sin \phi) = p_a,$$

$$\text{or: } \sin \phi = \frac{8811}{20853} = 0.4225, \quad \text{solve } \phi \approx 25^\circ \quad \text{Ans.}$$

P2.37 The inclined manometer in Fig. P2.37 contains Meriam red oil, $SG = 0.827$. Assume the reservoir is very large. If the inclined arm has graduations 1 inch apart, what should θ be if each graduation represents 1 psf of the pressure p_A ?

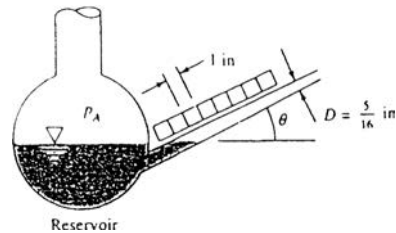

Fig. P2.37

Solution: The specific weight of the oil is $(0.827)(62.4) = 51.6$ lbf/ft³. If the reservoir level does not change and $\Delta L = 1$ inch is the scale marking, then

$$p_A (\text{gage}) = 1 \frac{\text{lbf}}{\text{ft}^2} = \gamma_{\text{oil}} \Delta z = \gamma_{\text{oil}} \Delta L \sin \theta = \left(51.6 \frac{\text{lbf}}{\text{ft}^3} \right) \left(\frac{1}{12} \text{ft} \right) \sin \theta,$$

$$\text{or: } \sin \theta = 0.2325 \quad \text{or: } \theta = 13.45^\circ \quad \text{Ans.}$$

P2.38 If the pressure in container A is 200 kPa, compute the pressure in container B.

Solution: The specific weights are

$$\gamma_{\text{oil}} = (0.8)(9790) = 7832 \text{ N/m}^3,$$

$$\gamma_{\text{mercury}} = 133,100 \text{ N/m}^3, \text{ and}$$

$$\gamma_{\text{water}} = 9790 \text{ N/m}^3.$$

Solution: Begin at B and proceed around to A.

$$200,000 + (9790)(0.18\text{m}) + (133100)(0.22 - 0.08\text{m}) - (0.8 \times 9790)(0.16\text{m}) = p_A$$

$$\text{Solve for } p_A = 219,000 \text{ Pa} = \mathbf{219 \text{ kPa}} \quad \text{Ans.}$$

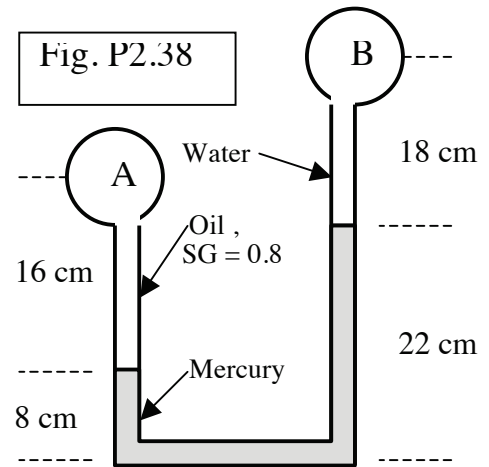

P2.39 In Fig. P2.39 the right leg of the manometer is open to the atmosphere. Find the gage pressure, in Pa, in the air gap in the tank. Neglect surface tension.

Solution: The two 8-cm legs of air are negligible (only 2 Pa). Begin at the right mercury interface and go to the air gap:

$$0 \text{ Pa-gage} + (133100 \text{ N/m}^3)(0.12 + 0.09 \text{ m}) \\ - (0.8 \times 9790 \text{ N/m}^3)(0.09 - 0.12 - 0.08 \text{ m})$$

$$= p_{\text{airgap}}$$

$$\text{or: } p_{\text{airgap}} = 27951 \text{ Pa} - 2271 \text{ Pa} \approx \mathbf{25700 \text{ Pa-gage}} \quad \text{Ans.}$$

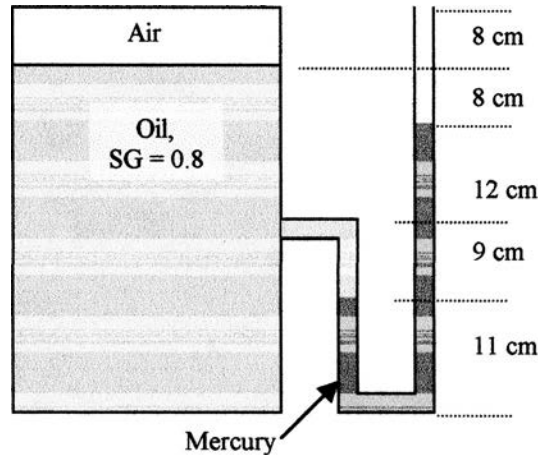

Fig. P2.39

P2.40 In Fig. P2.40, if pressure gage A reads 20 lbf/in^2 absolute, find the pressure in the closed air space B. The manometer fluid is Meriam red oil, $\text{SG} = 0.827$

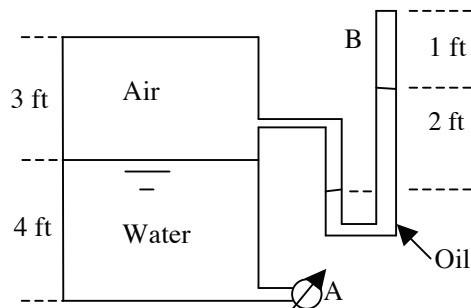

Fig. P2.40

Solution: For water take $\gamma = 62.4 \text{ lbf/ft}^3$. Neglect hydrostatic changes in the air. Proceed from A to B:

$$20(144) - 62.4(4 \text{ ft}) - (0.827)(62.4)(2 \text{ ft}) = p_B$$

$$\text{or: } 2880 - 249.6 - 103.2 = p_B = 2527 \text{ lbf/ft}^2 = \mathbf{17.6 \text{ lbf/in}^2} \quad \text{Ans.}$$

P2.41 The system in Fig. P2.41 is at 20°C. Determine the pressure at point A in pounds per square foot.

Solution: Take the specific weights of water and mercury from Table 2.1. Write the hydrostatic formula from point A to the water surface:

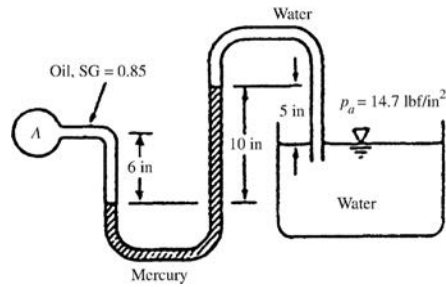

Fig. P2.41

$$p_A + (0.85)(62.4 \text{ lbf/ft}^3) \left(\frac{6}{12} \text{ ft} \right) - (846) \left(\frac{10}{12} \right) + (62.4) \left(\frac{5}{12} \right) = p_{\text{atm}} = (14.7)(144) \frac{\text{lbf}}{\text{ft}^2}$$

Solve for $p_A = 2770 \text{ lbf/ft}^2$ Ans.

P2.42 Small pressure differences can be measured by the two-fluid manometer in Fig. P2.42, where ρ_2 is only slightly larger than ρ_1 . Derive a formula for $p_A - p_B$ if the reservoirs are very large.

Solution: Apply the hydrostatic formula from A to B:

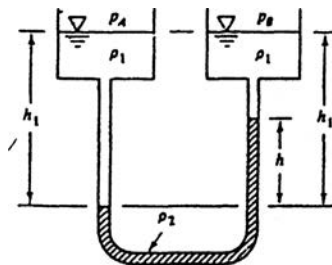

Fig. P2.42

$$p_A + \rho_1 g h_1 - \rho_2 g h - \rho_1 g (h_1 - h) = p_B$$

Solve for $p_A - p_B = (\rho_2 - \rho_1) g h$ Ans.

If $(\rho_2 - \rho_1)$ is very small, h will be very large for a given Δp (a sensitive manometer).

P2.43 The traditional method of measuring blood pressure uses a *sphygmomanometer*, first recording the highest (*systolic*) and then the lowest (*diastolic*) pressure from which flowing “Korotkoff” sounds can be heard. Patients with dangerous hypertension can exhibit systolic pressures as high as 5 lbf/in^2 . Normal levels, however, are 2.7 and 1.7 lbf/in^2 , respectively, for systolic and diastolic pressures. The manometer uses mercury and air as fluids. (a) How high should the manometer tube be? (b) Express normal systolic and diastolic blood pressure in millimeters of mercury.

Solution: (a) The manometer height must be at least large enough to accommodate the largest systolic pressure expected. Thus apply the hydrostatic relation using 5 lbf/in^2 as the pressure,

$$h = p_B / \rho g = (5 \text{ lbf/in}^2)(6895 \text{ Pa/lbf/in}^2) / (133100 \text{ N/m}^3) = 0.26 \text{ m}$$

So make the height about **30 cm**. *Ans. (a)*

(b) Convert the systolic and diastolic pressures by dividing them by mercury’s specific weight.

$$h_{\text{systolic}} = (2.7 \text{ lbf/in}^2)(144 \text{ in}^2/\text{ft}^2) / (846 \text{ lbf/ft}^3) = 0.46 \text{ ft Hg} = 140 \text{ mm Hg}$$

$$h_{\text{diastolic}} = (1.7 \text{ lbf/in}^2)(144 \text{ in}^2/\text{ft}^2) / (846 \text{ lbf/ft}^3) = 0.289 \text{ ft Hg} = 88 \text{ mm Hg}$$

The systolic/diastolic pressures are thus **140/88 mm Hg**. *Ans. (b)*

P2.44 Water flows downward in a pipe at 45° , as shown in Fig. P2.44. The mercury manometer reads a 6-in height. The pressure drop $p_2 - p_1$ is partly due to friction and partly due to gravity. Determine the total pressure drop and also the part due to friction only. Which part does the manometer read? Why?

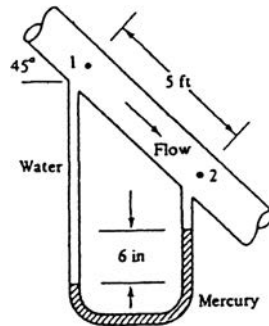

Fig. P2.44

Solution: Let “h” be the distance down from point 2 to the mercury-water interface in the right leg. Write the hydrostatic formula from 1 to 2:

$$p_1 + 62.4 \left(5 \sin 45^\circ + h + \frac{6}{12} \right) - 846 \left(\frac{6}{12} \right) - 62.4h = p_2,$$

$$p_1 - p_2 = \underbrace{(846 - 62.4)(6/12)}_{\dots \text{friction loss} \dots} - \underbrace{62.4(5 \sin 45^\circ)}_{\dots \text{gravity head} \dots} = 392 - 221$$

$$= 171 \frac{\text{lbf}}{\text{ft}^2} \quad \text{Ans.}$$

The manometer reads only the friction loss of 392 lbf/ft², not the gravity head of 221 psf.

P2.45 Determine the gage pressure at point A in Fig. P2.45, in pascals. Is it higher or lower than $P_{\text{atmosphere}}$?

Solution: Take $\gamma = 9790 \text{ N/m}^3$ for water and 133100 N/m^3 for mercury. Write the hydrostatic formula between the atmosphere and point A:

$$p_{\text{atm}} + (0.85)(9790)(0.4 \text{ m})$$

$$- (133100)(0.15 \text{ m}) - (12)(0.30 \text{ m})$$

$$+ (9790)(0.45 \text{ m}) = p_A,$$

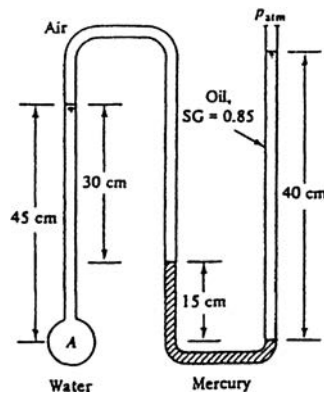

Fig. P2.45

$$\text{or: } p_A = p_{\text{atm}} - 12200 \text{ Pa} = 12200 \text{ Pa (vacuum)} \quad \text{Ans.}$$

P2.46 In Fig. P2.46 both ends of the manometer are open to the atmosphere. Estimate the specific gravity of fluid X.

Solution: The pressure at the bottom of the manometer must be the same regardless of which leg we approach through, left or right:

$$p_{\text{atm}} + (8720)(0.1) + (9790)(0.07) + \gamma_X(0.04) \quad (\text{left leg})$$

$$= p_{\text{atm}} + (8720)(0.09) + (9790)(0.05) + \gamma_X(0.06) \quad (\text{right leg})$$

$$\text{or: } \gamma_X = 14150 \text{ N/m}^3, \quad \text{SG}_X = \frac{14150}{9790} \approx 1.45 \quad \text{Ans.}$$

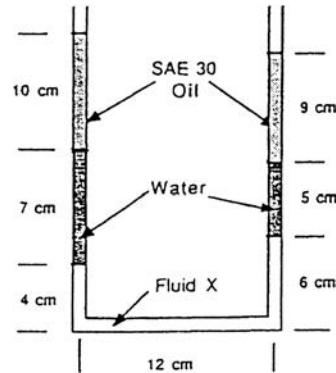

Fig. P2.46

P2.47 The cylindrical tank in Fig. P2.47 is being filled with 20°C water by a pump developing an exit pressure of 175 kPa. At the instant shown, the air pressure is 110 kPa and $H = 35$ cm. The pump stops when it can no longer raise the water pressure. Estimate “H” at that time.

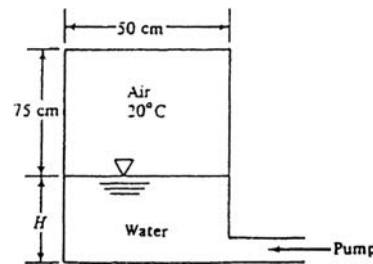

Fig. P2.47

Solution: At the end of pumping, the bottom water pressure must be 175 kPa:

$$p_{\text{air}} + 9790H = 175000$$

Meanwhile, assuming isothermal air compression, the final air pressure is such that

$$\frac{p_{\text{air}}}{110000} = \frac{\text{Vol}_{\text{old}}}{\text{Vol}_{\text{new}}} = \frac{\pi R^2(0.75 \text{ m})}{\pi R^2(1.1 \text{ m} - H)} = \frac{0.75}{1.1 - H}$$

where R is the tank radius. Combining these two gives a quadratic equation for H :

$$\frac{0.75(110000)}{1.1 - H} + 9790H = 175000, \quad \text{or} \quad H^2 - 18.98H + 11.24 = 0$$

The two roots are $H = 18.37$ m (ridiculous) or, properly, $H = 0.612$ m Ans.

P2.48 The system in Fig. P2.48

is open to 1 atm on the right side.

(a) If $L = 120$ cm, what is the air

pressure in container A?

(b) Conversely, if $p_A = 135$ kPa, what is the length L ?

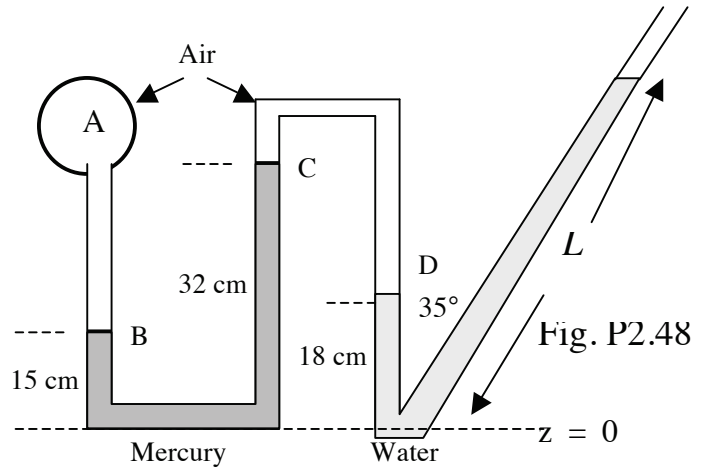

Solution: (a) The vertical elevation of the water surface in the slanted tube is $(1.2\text{m})(\sin 55^\circ) = 0.983$ m. Then the pressure at the 18-cm level of the water, point D, is

$$p_D = p_{atm} + \gamma_{water} \Delta z = 101350 \text{ Pa} + (9790 \frac{\text{N}}{\text{m}^3})(0.983 - 0.18\text{m}) = 109200 \text{ Pa}$$

Going up from D to C in air is negligible, less than 2 Pa. Thus $p_C \approx p_D = 109200$ Pa. Going down from point C to the level of point B increases the pressure in mercury:

$$p_B = p_C + \gamma_{mercury} \Delta z_{C-B} = 109200 + (133100 \frac{\text{N}}{\text{m}^3})(0.32 - 0.15\text{m}) = \mathbf{131800 \text{ Pa}} \text{ Ans.}(a)$$

This is the answer, since again it is negligible to go up to point A in low-density air.

(b) Given $p_A = 135$ kPa, go down from point A to point B with negligible air-pressure change, then jump across the mercury U-tube and go up to point C with a decrease:

$$p_C = p_B - \gamma_{mercury} \Delta z_{B-C} = 135000 - (133100)(0.32 - 0.15) = 112400 \text{ Pa}$$

Once again, $p_C \approx p_D \approx 112400$ Pa, jump across the water and then go up to the surface:

$$p_{atm} = p_D - \gamma_{water} \Delta z = 112400 - 9790(z_{surface} - 0.18\text{m}) = 101350 \text{ Pa}$$

$$\text{Solve for } z_{surface} \approx 1.306 \text{ m}$$

$$\text{Then the slanted distance } L = 1.306\text{m} / \sin 55^\circ = \mathbf{1.594 \text{ m}} \text{ Ans.}(b)$$

P2.49 Conduct an experiment: Place a thin wooden ruler on a table with a 40% overhang, as shown. Cover it with 2 full-size sheets of newspaper.

- Estimate the total force on top of the newspaper due to air pressure.
- With everyone out of the way, perform a karate chop on the outer end of the ruler.
- Explain the results in b.

Results: (a) Newsprint is about 27 in (0.686 m) by 22.5 in (0.572 m). Thus the force is:

$$F = pA = (101325 \text{ Pa})(0.686 \text{ m})(0.572 \text{ m}) \\ = \mathbf{39700 \text{ N!}} \quad \text{Ans.}$$

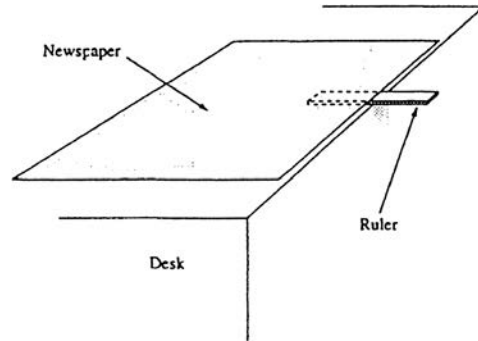

Fig. P2.48

- The newspaper will hold the ruler, which will probably *break* due to the chop. *Ans.*
- Chop is fast, air does not have time to rush in, partial vacuum under newspaper. *Ans.*

P2.50 A small submarine, with a hatch door 30 inches in diameter, is submerged in seawater. (a) If the water hydrostatic force on the hatch is 69,000 lbf, how deep is the sub? (b) If the sub is 350 ft deep, what is the hydrostatic force on the hatch?

Solution: In either case, the force is $p_{CG}A_{\text{hatch}}$. Stay with BG units. Convert 30 inches = 2.5 ft. For seawater, $\rho = 1025 \text{ kg/m}^3 \div 515.38 = 1.99 \text{ slug/ft}^3$, hence $\gamma = (1.99)(32.2) = 64.0 \text{ lbf/ft}^3$.

$$(a) F = p_{cg} A = (\gamma h) A = 69,000 \text{ lbf} = (64 \frac{\text{lbf}}{\text{ft}^3}) h \frac{\pi}{4} (2.5 \text{ ft})^2; \quad h = \mathbf{220 \text{ ft}} \quad \text{Ans.}(a)$$

$$(b) F = p_{cg} A = (\gamma h) A = (64 \frac{\text{lbf}}{\text{ft}^3})(350 \text{ ft}) \frac{\pi}{4} (2.5 \text{ ft})^2 = \mathbf{110,000 \text{ lbf}} \quad \text{Ans.}(b)$$

P2.51 Gate AB in Fig. P2.51 is 1.2 m long and 0.8 m into the paper. Neglecting atmospheric-pressure effects, compute the force F on the gate and its center of pressure position X .

Solution: The centroidal depth of the gate is

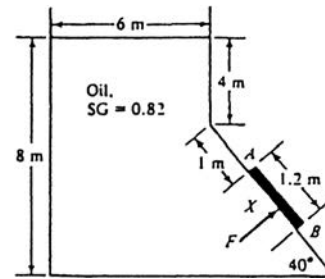

Fig. P2.51

$$h_{CG} = 4.0 + (1.0 + 0.6) \sin 40^\circ = 5.028 \text{ m},$$

$$\text{hence } F_{AB} = \gamma_{\text{oil}} h_{CG} A_{\text{gate}} = (0.82 \times 9790)(5.028)(1.2 \times 0.8) = \mathbf{38750 \text{ N}} \quad \text{Ans.}$$

The line of action of F is slightly below the centroid by the amount

$$y_{CP} = -\frac{I_{xx} \sin \theta}{h_{CG} A} = -\frac{(1/12)(0.8)(1.2)^3 \sin 40^\circ}{(5.028)(1.2 \times 0.8)} = -0.0153 \text{ m}$$

Thus the position of the center of pressure is at $X = 0.6 + 0.0153 \approx \mathbf{0.615 \text{ m}}$ Ans.

P2.52 Example 2.5 calculated the force on

plate AB and its line of action, using the

moment-of-inertia approach. Some teachers

say it is more instructive to calculate these

by *direct integration* of the pressure forces.

Using Figs. 2.52 and E2.5a, (a) find an expression

for the pressure variation $p(\zeta)$ along the plate;

(b) integrate this pressure to find the total force F ;

(c) integrate the moments about point A to find the position of the center of pressure.

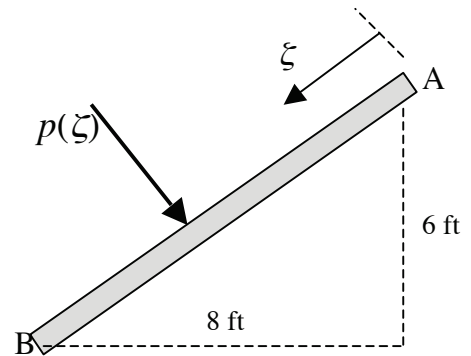

Fig. P2.52

Solution: (a) Point A is 9 ft deep, and point B is 15 ft deep, and $\gamma = 64 \text{ lbf/ft}^3$. Thus $p_A = (64 \text{ lbf/ft}^3)(9 \text{ ft}) = 576 \text{ lbf/ft}^2$ and $p_B = (64 \text{ lbf/ft}^3)(15 \text{ ft}) = 960 \text{ lbf/ft}^2$. Along the 10-ft length, pressure increases by $(960-576)/10 \text{ ft} = 38.4 \text{ lbf/ft}^2/\text{ft}$. Thus the pressure is

$$p(\zeta) = 576 + 38.4\zeta \quad (\text{lbf} / \text{ft}^2) \quad \text{Ans.}(a)$$

(b) Given that the plate width $b = 5 \text{ ft}$. Integrate for the total force on the plate:

$$\begin{aligned} F &= \int_{\text{plate}} p dA = \int_0^{10} p b d\zeta = \int_0^{10} (576 + 38.4\zeta)(5 \text{ ft}) d\zeta = \\ &= (5)(576\zeta + 38.4\zeta^2 / 2) \Big|_0^{10} = 28800 + 9600 = \mathbf{38,400 \text{ lbf}} \quad \text{Ans.}(b) \end{aligned}$$

(c) Find the moment of the pressure forces about point A and divide by the force:
The center of pressure is 5.417 ft down the plate from Point A.

$$\begin{aligned} M_A &= \int_{\text{plate}} p \zeta b dA = \int_0^{10} \zeta (576 + 38.4\zeta)(5 \text{ ft}) d\zeta = \\ &= (5)(576\zeta^2 / 2 + 38.4\zeta^3 / 3) \Big|_0^{10} = 144000 + 64000 = 208,000 \text{ ft} \cdot \text{lbf} \\ \text{Then } \zeta_{CP} &= \frac{M_A}{F} = \frac{208000 \text{ ft} \cdot \text{lbf}}{38400 \text{ lbf}} = \mathbf{5.42 \text{ ft}} \quad \text{Ans.}(c) \end{aligned}$$

P2.53 The Hoover Dam, in Arizona, encloses Lake Mead, which contains 10 trillion gallons of water. The dam is 1200 ft wide and the lake is 500 ft deep. (a) Estimate the hydrostatic force on the dam, in MN. (b) Explain how you might analyze the stress in the dam due to this hydrostatic force.

Solution: Convert to SI. The depth down to the centroid is 250 ft = 76.2 m. A crude estimate of the dam's wetted area is $(1200 \text{ ft})(500 \text{ ft}) = 600,000 \text{ ft}^2 = 55740 \text{ m}^2$. (a) Then the estimated force is

$$F = \gamma h_{cg} A = (9790 \text{ N} / \text{m}^3)(76.2 \text{ m})(55740 \text{ m}^2) = 4.16 \text{E}10 \text{ N} \approx \mathbf{42,000 \text{ MN}} \quad \text{Ans.}(b)$$

(b) The dam is not a "beam" or a "plate", so it exceeds the writer's stress-analysis ability. The dam's cross-section is roughly trapezoidal, with a variable bottom thickness. The writer suggests modeling this problem using commercial stress-analysis software, such as ANSYS or Nastran.

P2.54 In Fig. P2.54, the hydrostatic force F is the same on the bottom of all three containers, even though the weights of liquid above are quite different. The three bottom shapes and the fluids are the same. This is called the *hydrostatic paradox*. Explain why it is true and sketch a freebody of each of the liquid columns.

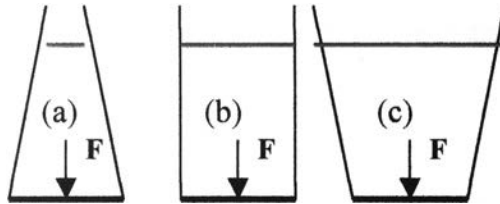
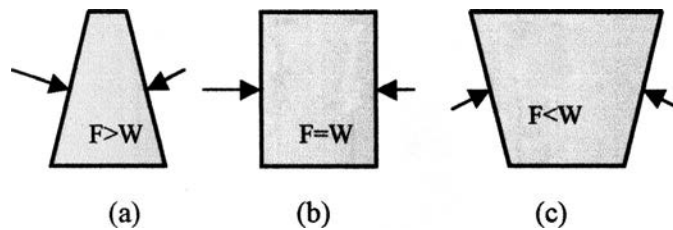

Fig. P2.54

Solution: The three freebodies are shown below. Pressure on the side-walls balances the forces. In (a), downward side-pressure components help add to a light W . In (b) side pressures are horizontal. In (c) upward side pressure helps reduce a heavy W .



P2.55 Gate AB in Fig. P2.55 is 5 ft wide into the paper, hinged at A, and restrained by a stop at B. Compute (a) the force on stop B; and (b) the reactions at A if $h = 9.5$ ft.

Solution: The centroid of AB is 2.0 ft below A, hence the centroidal depth is $h + 2 - 4 = 7.5$ ft. Then the total hydrostatic force on the gate is

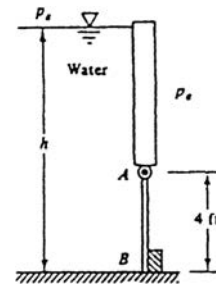

Fig. P2.55

$$F = \gamma h_{CG} A_{gate} = (62.4 \text{ lbf/ft}^3)(7.5 \text{ ft})(20 \text{ ft}^2) = 9360 \text{ lbf}$$

The C.P. is below the centroid by the amount

$$y_{CP} = -\frac{I_{xx} \sin \theta}{h_{CG} A} = \frac{(1/12)(5)(4)^3 \sin 90^\circ}{(7.5)(20)} = -0.178 \text{ ft}$$

This is shown on the freebody of the gate at right. We find force B_x with moments about A:

$$\begin{aligned} \sum M_A &= B_x(4.0) - (9360)(2.178) = 0, \\ \text{or: } B_x &= \mathbf{5100 \text{ lbf}} \quad (\text{to left}) \quad \text{Ans. (a)} \end{aligned}$$

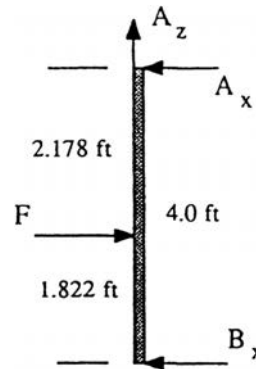

The reaction forces at A then follow from equilibrium of forces (with zero gate weight):

$$\begin{aligned} \sum F_x = 0 &= 9360 - 5100 - A_x, \quad \text{or: } A_x = \mathbf{4260 \text{ lbf}} \quad (\text{to left}) \\ \sum F_z = 0 &= A_z + W_{gate} \approx A_z, \quad \text{or: } A_z = \mathbf{0 \text{ lbf}} \quad \text{Ans. (b)} \end{aligned}$$

P2.56 For the gate of Prob. P2.55 above, stop “B” breaks if the force on it equals 9200 lbf. For what water depth h is this condition reached?

Solution: The formulas must be written in terms of the unknown centroidal depth h_{CG} :

$$\begin{aligned} h_{CG} &= h - 2 \quad F = \gamma h_{CG} A = (62.4)h_{CG}(20) = 1248h_{CG} \\ y_{CP} &= -\frac{I_{xx} \sin \theta}{h_{CG} A} = -\frac{(1/12)(5)(4)^3 \sin 90^\circ}{h_{CG}(20)} = -\frac{1.333}{h_{CG}} \end{aligned}$$

Then moments about A for the freebody in Prob. 2.55 above will yield the answer:

$$\sum M_A = 0 = 9200(4) - (1248h_{CG}) \left(2 + \frac{1.333}{h_{CG}} \right), \quad \text{or} \quad h_{CG} = 14.08 \text{ ft}, \quad h = \mathbf{16.08 \text{ ft}} \quad \text{Ans.}$$

P2.57 The square vertical panel ABCD in Fig. 2.57

is submerged in water at 20°C. Side AB is at least 1.7 m below the surface. Determine the difference between the hydrostatic forces on subpanels

ABD and BCD.

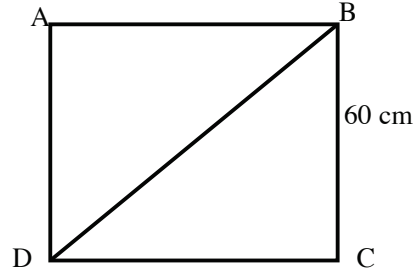

Fig. P2.57

Solution: Let H be the distance down from the surface to line AB. Take $\gamma_{\text{water}} = 9790 \text{ N/m}^3$. The subpanel areas are each 0.18 m^2 . Then the difference between these two subpanel forces is

$$\begin{aligned} F_{BCD} - F_{ABD} &= [p_a + \gamma(H + 0.4m)]A_{BCD} - [p_a + \gamma(H + 0.2m)]A_{ABD} \\ &= \gamma(0.2m)A_{BCD} = (9790 \text{ N/m}^3)(0.2m)(0.18 \text{ m}^2) = \mathbf{362 \text{ N}} \quad \text{Ans} \end{aligned}$$

Note that atmospheric pressure and the depth H to line AB cancel in this calculation.

P2.58 In Fig. P2.58, weightless cover gate AB closes a circular opening 80 cm in diameter when weighed down by the 200-kg mass shown. What water level h will dislodge the gate?

Solution: The centroidal depth is exactly

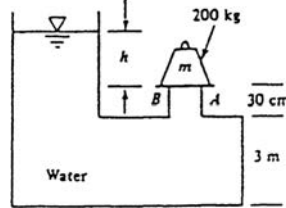

Fig. P2.58

equal to h and force F will be upward on the gate. Dislodging occurs when F equals the weight:

$$F = \gamma h_{CG} A_{\text{gate}} = (9790 \text{ N/m}^3) h \frac{\pi}{4} (0.8 \text{ m})^2 = W = (200)(9.81) \text{ N}$$

Solve for $h = \mathbf{0.40 \text{ m}} \quad \text{Ans.}$

P2.59 Gate AB has length L , width b into the paper, is hinged at B, and has negligible weight. The liquid level h remains at the top of the gate for any angle θ . Find an analytic expression for the force P , perpendicular to AB, required to keep the gate in equilibrium.

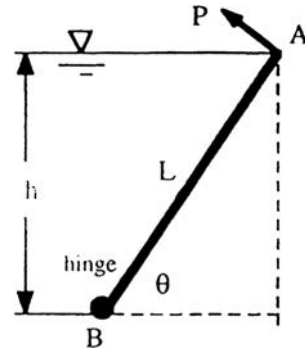

Solution: The centroid of the gate remains at distance $L/2$ from A and depth $h/2$ below

the surface. For any θ , then, the hydrostatic force is $F = \gamma(h/2)Lb$. The moment of inertia of the gate is $(1/12)bL^3$, hence $y_{CP} = -(1/12)bL^3 \sin \theta / [(h/2)Lb]$, and the center of pressure is $(L/2 - y_{CP})$ from point B. Summing moments about hinge B yields

$$PL = F(L/2 - y_{CP}), \quad \text{or} \quad \mathbf{P = (\lambda hb / 4)[L - L^2 \sin \theta / (3h)] \quad Ans.}$$

P2.60 In Fig. P2.60, vertical, unsymmetrical trapezoidal panel ABCD is submerged in fresh water with side AB 12 ft below the surface. Since trapezoid formulas are complicated, (a) estimate, reasonably, the water force on the panel, in lbf, neglecting atmospheric pressure. For extra credit, (b) look up the formula and compute the exact force on the panel.

Fig. P2.60

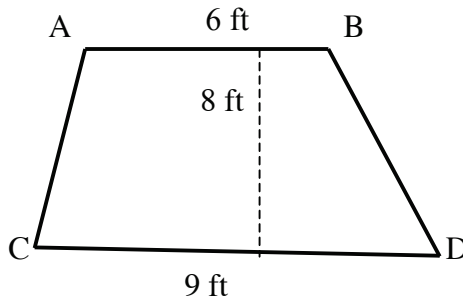

Solution: For water, take $\gamma = 62.4 \text{ lbf/ft}^3$. The area of the panel is $\frac{1}{2}(6+9)(8) = 60 \text{ ft}^2$. (a) The panel centroid should be slightly below the mid-panel, say, about 4.5 ft below AB. Then we estimate

$$F \approx \gamma H_{cg} A = (62.4 \text{ lbf / ft}^3)(12 + 4.5 \text{ ft})(60 \text{ ft}^2) \approx \mathbf{61,800 \text{ lbf} \quad Ans.(a)}$$

(b) Look up the centroid of a trapezoid, which is independent of symmetry. If b_1 and b_2 are the top and bottom sides, the centroid lies at a distance Z above the bottom side, given by

$$Z = \frac{(b_2 + 2b_1)}{3(b_1 + b_2)} h = \frac{9 + 2(6)}{3(6 + 9)} (8) = (0.467)(8) = 3.73 \text{ ft above CD}$$

The centroid is thus $(8 - 3.73) = 4.27$ ft below AB. Our guess wasn't bad. Then our exact estimate is

$$F \approx \gamma H_{cg} A = (62.4 \text{ lbf/ft}^3)(12 + 4.27 \text{ ft})(60 \text{ ft}^2) \approx \mathbf{60,900 \text{ lbf}} \quad \text{Ans.}(b)$$

P2.61 Gate AB in Fig. P2.61 is a homo-geneous mass of 180 kg, 1.2 m wide into the paper, resting on smooth bottom B. All fluids are at 20°C. For what water depth h will the force at point B be zero?

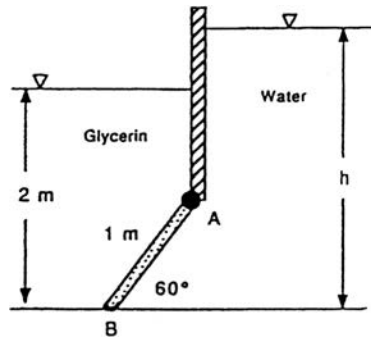

Fig. P2.61

Solution: Let $\gamma = 12360 \text{ N/m}^3$ for glycerin and 9790 N/m^3 for water. The centroid of AB is 0.433 m vertically below A, so $h_{CG} = 2.0 - 0.433 = 1.567$ m, and we may compute the glycerin force and its line of action:

$$F_g = \gamma \bar{h} A = (12360)(1.567)(1.2) = 23242 \text{ N}$$

$$y_{CP,g} = -\frac{(1/12)(1.2)(1)^3 \sin 60^\circ}{(1.567)(1.2)} = -0.0461 \text{ m}$$

These are shown on the freebody below. The water force and its line of action are shown without numbers, because they depend upon the centroidal depth on the water side:

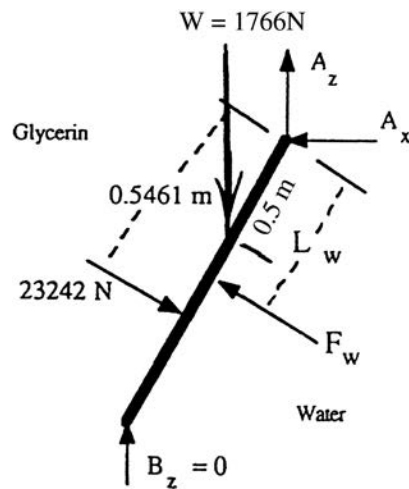

$$F_w = (9790)h_{CG}(1.2)$$

$$y_{CP} = -\frac{(1/12)(1.2)(1)^3 \sin 60^\circ}{h_{CG}(1.2)} = -\frac{0.0722}{h_{CG}}$$

The weight of the gate, $W = 180(9.81) = 1766$ N, acts at the centroid, as shown above. Since the x-force at B equals zero, we may sum moments counterclockwise about A to find the water depth:

$$\begin{aligned} \sum M_A = 0 = & (23242)(0.5461) + (1766)(0.5 \cos 60^\circ) \\ & - (9790)h_{CG}(1.2)(0.5 + 0.0722/h_{CG}) \end{aligned}$$

$$\text{Solve for } h_{CG, \text{water}} = 2.09 \text{ m, or: } h = h_{CG} + 0.433 = \mathbf{2.52 \text{ m}} \quad \text{Ans.}$$

P2.62 Gate AB in Fig. P2.62 is 15 ft long and 8 ft wide into the paper, hinged at B with a stop at A. The gate is 1-in-thick steel, SG = 7.85. Compute the 20°C water level h for which the gate will start to fall.

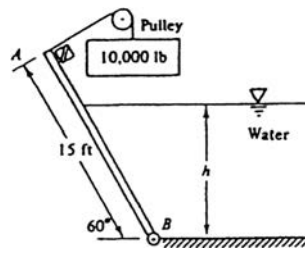

Fig. P2.62

Solution: Only the length $(h \csc 60^\circ)$ of the gate lies below the water. Only this part contributes to the hydrostatic force shown in the freebody below.

$$F = \gamma h_{CG} A = (62.4) \left(\frac{h}{2} \right) (8h \csc 60^\circ)$$

$$= 288.2h^2 \text{ (lbf)}$$

$$y_{CP} = - \frac{(1/12)(8)(h \csc 60^\circ)^3 \sin 60^\circ}{(h/2)(8h \csc 60^\circ)}$$

$$= - \frac{h}{6} \csc 60^\circ$$

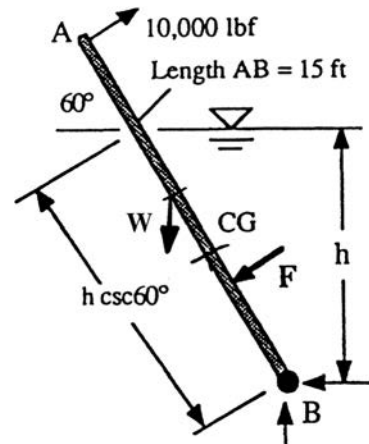

The weight of the gate is $(7.85)(62.4 \text{ lbf/ft}^3)(15 \text{ ft})(1/12 \text{ ft})(8 \text{ ft}) = 4898 \text{ lbf}$. This weight acts downward at the CG of the *full gate* as shown (not the CG of the submerged portion). Thus, W is 7.5 ft above point B and has moment arm $(7.5 \cos 60^\circ \text{ ft})$ about B.

We are now in a position to find h by summing moments about the hinge line B:

$$\sum M_B = (10000)(15) - (288.2h^2)[(h/2) \csc 60^\circ - (h/6) \csc 60^\circ] - 4898(7.5 \cos 60^\circ) = 0,$$

$$\text{or: } 110.9h^3 = 150000 - 18369, \quad h = (131631/110.9)^{1/3} = \mathbf{10.6 \text{ ft}} \quad \text{Ans.}$$

P2.63 The tank in Fig. P2.63 has a 4-cm-diameter plug which will pop out if the hydrostatic force on it reaches 25 N. For 20°C fluids, what will be the reading h on the manometer when this happens?

Solution: The water depth when the plug pops out is

$$F = 25 \text{ N} = \gamma h_{CG} A = (9790) h_{CG} \frac{\pi(0.04)^2}{4}$$

$$\text{or } h_{CG} = 2.032 \text{ m}$$

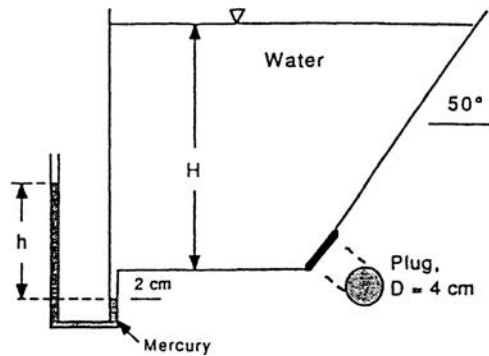

Fig. P2.63

It makes little numerical difference, but the mercury-water interface is a little deeper than this, by the amount $(0.02 \sin 50^\circ)$ of plug-depth, plus 2 cm of tube length. Thus

$$p_{\text{atm}} + (9790)(2.032 + 0.02 \sin 50^\circ + 0.02) - (133100)h = p_{\text{atm}},$$

$$\text{or: } h \approx \mathbf{0.152 \text{ m}} \quad \text{Ans.}$$

P2.64 Gate ABC in Fig. P2.64 has a fixed hinge at B and is 2 m wide into the paper. If the water level is high enough, the gate will open. Compute the depth h for which this happens.

Solution: Let $H = (h - 1 \text{ meter})$ be the depth down to the level AB. The forces on AB and BC are shown in the freebody at right. The moments of these forces about B are equal when the gate opens:

$$\begin{aligned}\sum M_B = 0 &= \gamma H(0.2)b(0.1) \\ &= \gamma \left(\frac{H}{2}\right)(Hb)\left(\frac{H}{3}\right)\end{aligned}$$

$$\text{or: } H = 0.346 \text{ m,}$$

$$h = H + 1 = \mathbf{1.346 \text{ m}} \quad \text{Ans.}$$

This solution is independent of both the water density and the gate width b into the paper.

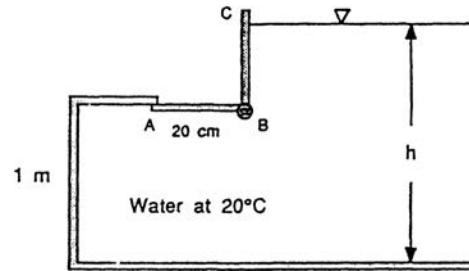
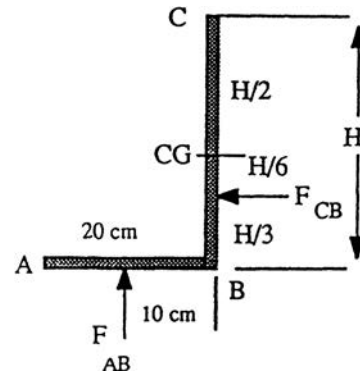

Fig. P2.64



P2.65 Gate AB in Fig. P2.65 is semi-circular, hinged at B, and held by a horizontal force P at point A. Determine the required force P for equilibrium.

Solution: The centroid of a semi-circle is at $4R/3\pi \approx 1.273 \text{ m}$ off the bottom, as shown in the sketch at right. Thus it is $3.0 - 1.273 = 1.727 \text{ m}$ down from the force P . The water force F is

$$\begin{aligned}F &= \gamma h_{CG} A = (9790)(5.0 + 1.727) \frac{\pi}{2} (3)^2 \\ &= 931000 \text{ N}\end{aligned}$$

The line of action of F lies below the CG:

$$y_{CP} = -\frac{I_{xx} \sin \theta}{h_{CG} A} = -\frac{(0.10976)(3)^4 \sin 90^\circ}{(5 + 1.727)(\pi/2)(3)^2} = -0.0935 \text{ m}$$

Then summing moments about B yields the proper support force P :

$$\sum M_B = 0 = (931000)(1.273 - 0.0935) - 3P, \quad \text{or: } P = \mathbf{366000 \text{ N}} \quad \text{Ans.}$$

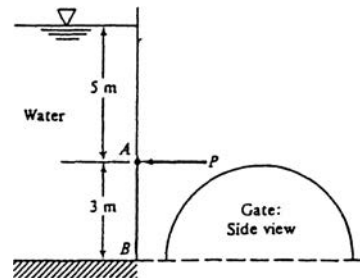
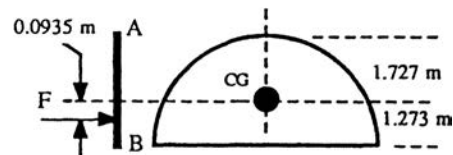

Fig. P2.65



P2.66 Dam ABC in Fig. P2.66 is 30 m wide into the paper and is concrete (SG \approx P2.40). Find the hydrostatic force on surface AB and its moment about C. Could this force tip the dam over? Would fluid seepage under the dam change your argument?

Solution: The centroid of surface AB is 40 m deep, and the total force on AB is

$$F = \gamma h_{CG} A = (9790)(40)(100 \times 30) \\ = 1.175E9 \text{ N}$$

The line of action of this force is two-thirds of the way down along AB, or 66.67 m from A. This is seen either by inspection (A is at the surface) or by the usual formula:

$$y_{CP} = -\frac{I_{xx} \sin \theta}{h_{CG} A} = -\frac{(1/12)(30)(100)^3 \sin(53.13^\circ)}{(40)(30 \times 100)} = -16.67 \text{ m}$$

to be added to the 50-m distance from A to the centroid, or $50 + 16.67 = 66.67$ m. As shown in the figure, the line of action of F is 2.67 m to the left of a line up from C normal to AB. The moment of F about C is thus

$$M_C = FL = (1.175E9)(66.67 - 64.0) \approx 3.13E9 \text{ N} \cdot \text{m} \quad \text{Ans.}$$

This moment is counterclockwise, hence it cannot tip over the dam. If there were seepage under the dam, the main support force at the bottom of the dam would shift to the left of point C and might indeed cause the dam to tip over.

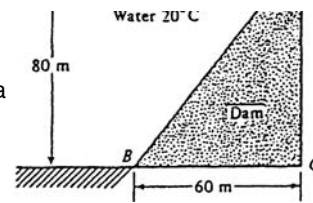
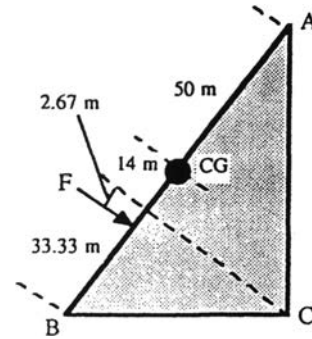

Fig. P2.66



P2.67 Generalize Prob. P2.66 with length AB as “H”, length BC as “L”, and angle ABC as “ θ ”, with width “b” into the paper. If the dam material has specific gravity “SG”, with no seepage, find the critical angle θ_c for which the dam will just tip over to the right. Evaluate this expression for SG = P2.40.

Solution: By geometry, $L = H \cos \theta$ and the vertical height of the dam is $H \sin \theta$. The

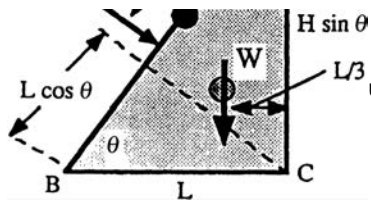

Fig. P2.67

force F on surface AB is $\gamma(H/2)(\sin\theta)Hb$, and its position is at $2H/3$ down from point A , as shown in the figure. Its moment arm about C is thus $(H/3 - L\cos\theta)$. Meanwhile the weight of the dam is $W = (SG)\gamma(L/2)H(\sin\theta)b$, with a moment arm $L/3$ as shown. Then summation of clockwise moments about C gives, for critical “tip-over” conditions,

$$\sum M_C = 0 = \left(\gamma \frac{H}{2} \sin \theta Hb \right) \left[\frac{H}{3} - L \cos \theta \right] - \left[SG(\gamma) \frac{L}{2} H \sin \theta b \right] \left(\frac{L}{3} \right) \quad \text{with } L = H \cos \theta.$$

$$\text{Solve for } \cos^2 \theta_c = \frac{1}{3 + SG} \quad \text{Ans.}$$

Any angle greater than θ_c will cause tip-over to the right. For the particular case of concrete, $SG \approx 2.40$, $\cos \theta_c \approx 0.430$, or $\theta_c \approx 64.5^\circ$, which is greater than the given angle $\theta = 53.13^\circ$ in Prob. P2.66, hence there was no tipping in that problem.

P2.68 Isosceles triangle gate AB in Fig. P2.68 is hinged at A and weighs 1500 N . What horizontal force P is required at point B for equilibrium?

Solution: The gate is $2.0/\sin 50^\circ = 2.611 \text{ m}$ long from A to B and its area is 1.3054 m^2 . Its centroid is $1/3$ of the way down from A , so the centroidal depth is $3.0 + 0.667 \text{ m}$. The force on the gate is

$$F = \gamma h_{CG} A = (0.83)(9790)(3.667)(1.3054) = 38894 \text{ N}$$

The position of this force is below the centroid:

$$y_{CP} = -\frac{I_{xx} \sin \theta}{h_{CG} A}$$

$$= -\frac{(1/36)(1.0)(2.611)^3 \sin 50^\circ}{(3.667)(1.3054)} = -0.0791 \text{ m}$$

The force and its position are shown in the freebody at upper right. The gate weight of 1500 N is assumed at the centroid of the plate, with moment arm 0.559 meters about point A . Summing moments about point A gives the required force P :

$$\sum M_A = 0 = P(2.0) + 1500(0.559) - 38894(0.870 + 0.0791),$$

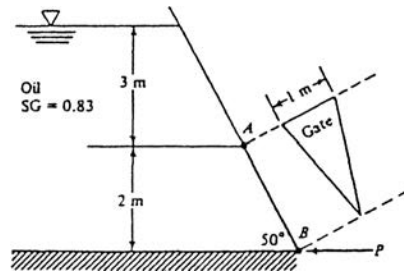
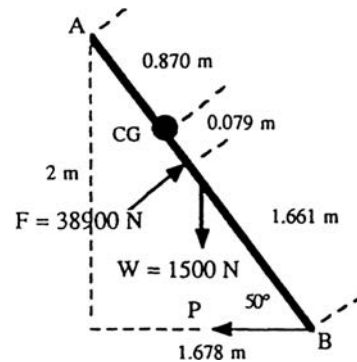
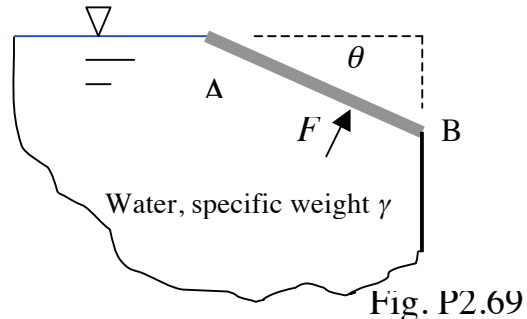

Fig. P2.68



Solve for $P = 18040 \text{ N}$ Ans.

P2.69 Consider the slanted plate AB of length L in Fig. P2.69. (a) Is the hydrostatic force F on the plate equal to the weight of the *missing water* above the plate? If not, correct this hypothesis. Neglect the atmosphere.



(b) Can a “missing water” approach be generalized to *curved* plates of this type?

Solution: (a) The actual force F equals the pressure at the centroid times the plate area: But the weight of the “missing water” is

$$F = p_{CG} A_{plate} = \gamma h_{CG} Lb = \gamma \frac{L \sin \theta}{2} Lb = \frac{\gamma}{2} L^2 b \sin \theta$$

$$W_{missing} = \gamma \mathcal{V}_{missing} = \gamma \left[\frac{1}{2} (L \sin \theta) (L \cos \theta) b \right] = \frac{\gamma}{2} L^2 b \sin \theta \cos \theta$$

Why the discrepancy? Because the actual plate force *is not vertical*. Its vertical component is $F \cos \theta = W_{missing}$. The missing-water weight equals the *vertical* component of the force. *Ans.(a)* This same approach applies to *curved* plates with missing water. *Ans.(b)*

P2.70 The swing-check valve in Fig. P2.70 covers a 22.86-cm diameter opening in the slanted wall. The hinge is 15 cm from the centerline, as shown. The valve will open when the hinge

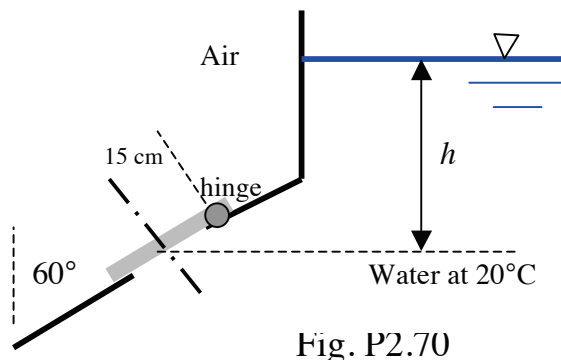

Fig. P2.70

moment is 50 N-m. Find the value of h for the water to cause this condition.

Solution: For water, take $\gamma = 9790 \text{ N/m}^3$. The hydrostatic force on the valve is

$$F = p_{CG} A = \gamma h(\pi) R^2 = (9790 \frac{\text{N}}{\text{m}^3}) h(\pi)(0.1143\text{m})^2 = 401.8 h$$

The center of pressure is slightly below the centerline by an amount

$$y_{CP} = - \frac{\gamma \sin \theta I_{xx}}{F} = \frac{(9790) \sin(30^\circ)(\pi/4)(0.1143)^4}{100.45 h} = \frac{0.00653}{h}$$

The 60° angle in the figure is a red herring – we need the **30° angle** with the horizontal. Then the moment about the hinge is

$$M_{hinge} = Fl = (401.8h)(0.15 + \frac{0.00653}{h}) = 50 \text{ N-m}$$

Solve for $h = \mathbf{0.79 \text{ m}}$ *Ans.*

Since y_{CP} is so small (2 mm), you don't really need Excel. Just iterate once or twice.

P2.71 In Fig. P2.71 gate AB is 3 m wide into the paper and is connected by a rod and pulley to a concrete sphere (SG = 2.40). What sphere diameter is just right to close the gate?

Solution: The centroid of AB is 10 m down from the surface, hence the hydrostatic force is

$$F = \gamma h_{CG} A = (9790)(10)(4 \times 3) \\ = 1.175E6 \text{ N}$$

The line of action is slightly below the centroid:

$$y_{CP} = -\frac{(1/12)(3)(4)^3 \sin 90^\circ}{(10)(12)} = -0.133 \text{ m}$$

Sum moments about B in the freebody at right to find the pulley force or weight W:

$$\sum M_B = 0 = W(6 + 8 + 4 \text{ m}) - (1.175E6)(2.0 - 0.133 \text{ m}), \text{ or } W = 121800 \text{ N}$$

Set this value equal to the weight of a solid concrete sphere:

$$W = 121800 \text{ N} = \gamma_{\text{concrete}} \frac{\pi}{6} D^3 = (2.4)(9790) \frac{\pi}{6} D^3, \text{ or: } D_{\text{sphere}} = \mathbf{2.15 \text{ m}} \text{ Ans.}$$

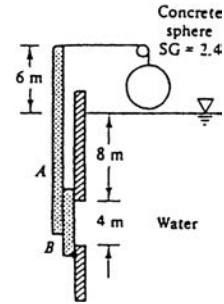
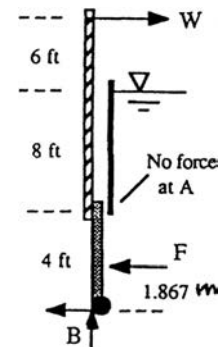
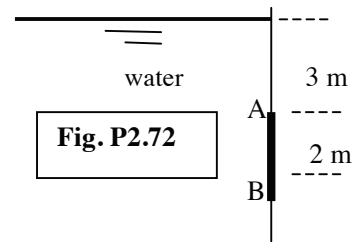

Fig. P2.71



P2.72 In Fig. P2.72 gate AB is circular.

Find the moment of the hydrostatic force on this gate about axis A. Neglect atmospheric pressure.



Solution: The gate centroid is $3+1 = 4$ m down from the surface. The hydrostatic force is thus

$$F = \gamma h_{cg} A_{gate} = (9790 \text{ N/m}^3)(4 \text{ m})[\pi(0.5 \text{ m})^2] = 30,800 \text{ N}$$

From Fig. 2.13 and Eq. 2.29, for a circle, the center of pressure CP is below the centroid by the amount

$$y_{CP} = -\frac{I_{xx} \sin \theta}{h_{CG} A} = -\frac{[\pi(1 \text{ m})^4 / 4] \sin(90^\circ)}{(4 \text{ m})[\pi(1 \text{ m})^2]} = -0.0625 \text{ m}$$

Then the hydrostatic force acts $(1 \text{ m} + 0.0625 \text{ m})$ below point A. The moment about A is

$$M_A = (30,900 \text{ N})(1.0625 \text{ m}) = \mathbf{32,700 \text{ N} \cdot \text{m} \text{ Ans.}}$$

P2.73 Weightless gate AB is 5 ft wide into the paper and opens to let fresh water out when the ocean tide is falling. The hinge at A is 2 ft above the freshwater level. Find h when the gate opens.

Solution: There are two different hydro-static forces and two different lines of action. On the water side,

$$F_w = \gamma h_{CG} A = (62.4)(5)(10 \times 5) = 15600 \text{ lbf}$$

positioned at 3.33 ft above point B. In the seawater,

$$\begin{aligned} F_s &= (1.025 \times 62.4) \left(\frac{h}{2} \right) (5h) \\ &= 159.9h^2 \text{ (lbf)} \end{aligned}$$

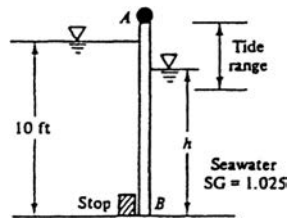
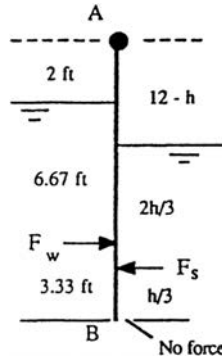

Fig. P2.73



positioned at $h/3$ above point B. Summing moments about hinge point A gives the desired seawater depth h :

$$\sum M_A = 0 = (159.9h^2)(12 - h/3) - (15600)(12 - 3.33),$$

or $53.3h^3 - 1918.8h^2 + 135200 = 0$, solve for $h = \mathbf{9.85 \text{ ft}}$ Ans.

P2.74 Find the height H in Fig. P2.74 for which the hydrostatic force on the rectangular panel is the same as the force on the semicircular panel below.

Solution: Find the force on each panel and set them equal:

$$F_{\text{rect}} = \gamma h_{\text{CG}} A_{\text{rect}} = \gamma (H/2) [(2R)(H)] = \gamma R H^2$$

$$F_{\text{semi}} = \gamma h_{\text{CG}} A_{\text{semi}} = \gamma (H + 4R/3\pi) [(\pi/2)R^2]$$

Set them equal, cancel γ : $RH^2 = (\pi/2)R^2H + 2R^3/3$, or: $H^2 - (\pi/2)RH - 2R^2/3 = 0$

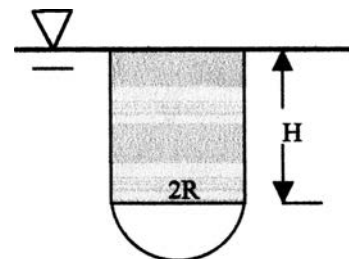

Fig. P2.74

Finally, $H = R[\pi/4 + \{(\pi/4)^2 + 2/3\}^{1/2}] \approx 1.92R$ *Ans.*

P2.75 The cap at point B on the 5-cm-diameter tube in Fig. P2.75 will be dislodged when the hydrostatic force on its base reaches 22 lbf. For what water depth h does this occur?

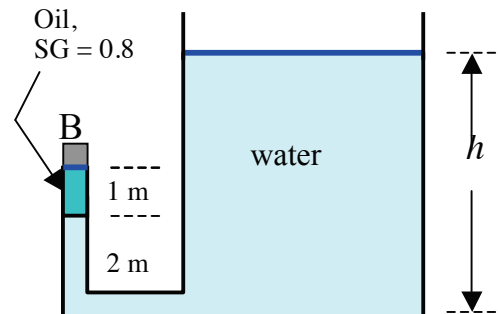

Fig. P2.75

Solution: Convert the cap force to SI units: $22 \text{ lbf} \times 4.4482 = 97.9 \text{ N}$. Then the “dislodging” pressure just under cap B will be

$$p_B = \frac{F}{A_{tube}} = \frac{97.9 \text{ N}}{(\pi/4)(0.05 \text{ m})^2} = 49,800 \text{ Pa (gage)}$$

Begin at point B, go down and around the two fluids to the surface of the tank:

$$49800 \text{ Pa} + (0.8)(9790 \frac{\text{N}}{\text{m}^3})(1 \text{ m}) + (9790 \frac{\text{N}}{\text{m}^3})(2 \text{ m}) - (9790 \frac{\text{N}}{\text{m}^3})(h) = p_{surface} = 0 \text{ (gage)}$$

$$\text{Solve for } h = \frac{77250 \text{ Pa}}{9790 \text{ N/m}^3} = 7.89 \text{ m} \quad \textit{Ans.}$$

P2.76 Panel BC in Fig. P2.76 is circular. Compute (a) the hydrostatic force of the water on the panel; (b) its center of pressure; and (c) the moment of this force about point B.

Solution: (a) The hydrostatic force on the gate is:

$$\begin{aligned} F &= \gamma h_{CG} A \\ &= (9790 \text{ N/m}^3)(4.5 \text{ m}) \sin 50^\circ (\pi)(1.5 \text{ m})^2 \\ &= \mathbf{239 \text{ kN}} \quad \text{Ans. (a)} \end{aligned}$$

(b) The center of pressure of the force is:

$$\begin{aligned} y_{CP} &= \frac{I_{xx} \sin \theta}{h_{CG} A} = \frac{\frac{\pi}{4} r^4 \sin \theta}{h_{CG} A} \\ &= \frac{\frac{\pi}{4} (1.5)^4 \sin 50^\circ}{(4.5 \sin 50^\circ)(\pi)(1.5^2)} = \mathbf{0.125 \text{ m}} \quad \text{Ans. (b)} \end{aligned}$$

Thus y is **1.625 m** down along the panel from B (or 0.125 m down from the center of the circle).

(c) The moment about B due to the hydrostatic force is,

$$M_B = (238550 \text{ N})(1.625 \text{ m}) = 387,600 \text{ N} \cdot \text{m} = \mathbf{388 \text{ kN} \cdot \text{m}} \quad \text{Ans. (c)}$$

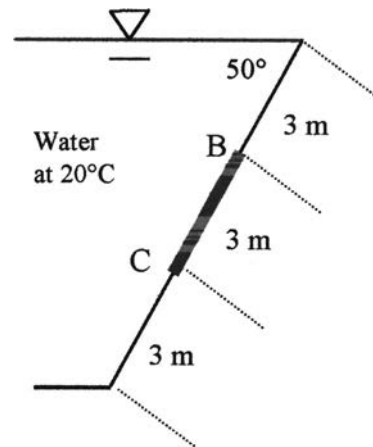

Fig. P2.76

P2.77 Circular gate ABC is hinged at B. Compute the force just sufficient to keep the gate from opening when $h = 8 \text{ m}$. Neglect atmospheric pressure.

Solution: The hydrostatic force on the gate is

$$\begin{aligned} F &= \gamma h_{CG} A = (9790)(8 \text{ m})(\pi \text{ m}^2) \\ &= 246050 \text{ N} \end{aligned}$$

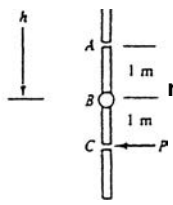

Fig. P2.77

This force acts below point B by the distance

$$y_{CP} = -\frac{I_{xx}\sin\theta}{h_{CG}A} = -\frac{(\pi/4)(1)^4\sin 90^\circ}{(8)(\pi)} = -0.03125 \text{ m}$$

Summing moments about B gives $P(1 \text{ m}) = (246050)(0.03125 \text{ m})$, or $P \approx 7690 \text{ N}$ Ans.

P2.78 Panels AB and CD are each

120 cm wide into the paper. (a) Can you deduce, by inspection, which panel has the larger water force?

(b) Even if your deduction is brilliant, calculate the panel forces anyway.

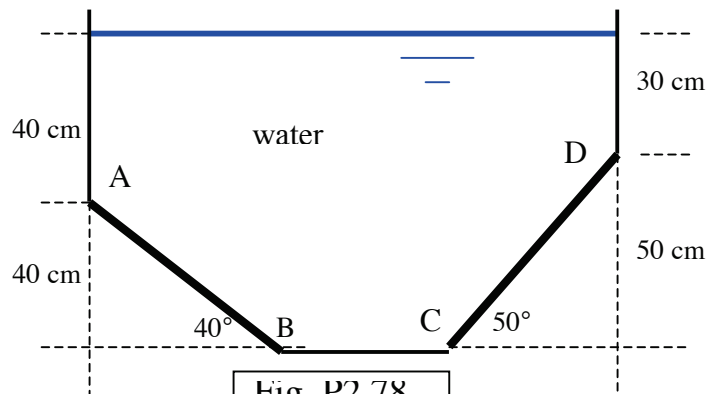

Fig. P2.78

Solution: (a) The writer is unable to deduce by inspection which panel force is larger. CD is longer than AB, but its centroid is not as deep. If you have a great insight, let me know.

(b) The length of AB is $(40\text{cm})/\sin 40^\circ = 62.23 \text{ cm}$. The centroid of AB is $40+20 = 60 \text{ cm}$ below the surface. The length of CD is $(50\text{cm})/\sin 50^\circ = 65.27 \text{ cm}$. The centroid of CD is $30+25 = 55 \text{ cm}$ below the surface. Calculate the two forces:

$$F_{AB} = \gamma h_{AB} A_{AB} = (9790 \frac{N}{m^3})(0.6\text{m})(0.6223\text{m})(1.2\text{m}) = 4390 \text{ N}$$

$$F_{CD} = \gamma h_{CD} A_{CD} = (9790 \frac{N}{m^3})(0.55\text{m})(0.6527\text{m})(1.2\text{m}) = 4220 \text{ N} \quad \text{Ans. (b)}$$

It turns out that panel AB has the larger force, but it is only 4 percent larger.

P2.79 Gate ABC in Fig. P2.79 is 1-m-square and hinged at B. It opens automatically when the water level is high enough. Neglecting atmospheric pressure, determine the lowest level h for which the gate will open. Is your result independent of the liquid density?

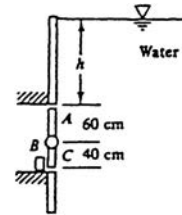
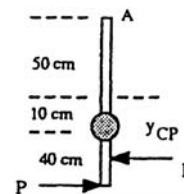

Fig. P2.79

Solution: The gate will open when the hydrostatic force F on the gate is *above* B , that is, when

$$|y_{CP}| = \frac{I_{xx} \sin \theta}{h_{CG} A}$$

$$= \frac{(1/12)(1 \text{ m})(1 \text{ m})^3 \sin 90^\circ}{(h + 0.5 \text{ m})(1 \text{ m}^2)} < 0.1 \text{ m},$$



$$\text{or: } h + 0.5 > 0.833 \text{ m, or: } \mathbf{h > 0.333 \text{ m}} \quad \text{Ans.}$$

Indeed, this result is independent of the liquid density.

***P2.80** A concrete dam (SG = 2.5) is made in the shape of an isosceles triangle, as in Fig. P2.80. Analyze this geometry to find the range of angles θ for which the hydrostatic force will tend to tip the dam over at point B. The width into the paper is b .

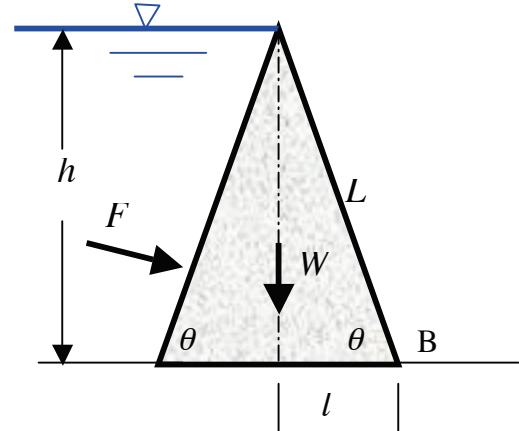

Solution: The critical angle is when the hydrostatic force F causes a clockwise moment equal to the counterclockwise moment of the dam weight W . The length L of the slanted side of the dam is $L = h/\sin\theta$. The force F is two-thirds of the way down this face. The moment arm of the weight about point B is $l = h/\tan\theta$. The moment arm of F about point B is quite difficult, and you should check this:

$$\text{Moment arm of } F \text{ about B is } \frac{L}{3} - 2l \cos\theta = \frac{1}{3} \frac{h}{\sin\theta} - \frac{2h}{\tan\theta} \cos\theta$$

Evaluate the two forces and then their moments:

$$F = \gamma \frac{h}{2} \frac{h}{\sin \theta} b \quad ; \quad W = SG \gamma v_{dam} = SG \gamma h \frac{h}{\tan \theta} b$$

$$\Sigma M_B = \frac{\gamma h^2 b}{2 \sin \theta} \left(\frac{h}{3 \sin \theta} - \frac{2h \cos \theta}{\tan \theta} \right) - \frac{SG \gamma h^2 b}{\tan \theta} \left(\frac{h}{\tan \theta} \right) \quad \text{clockwise}$$

When the moment is negative (small θ), the dam is *stable*, it will not tip over. The moment is zero, for $SG = 2.5$, at $\theta = 77.4^\circ$. Thus tipping is possible in the range $\theta > 77.4^\circ$. *Ans.*
 NOTE: This answer is independent of the numerical values of h , g , or b but requires $SG = 2.5$.

P2.81 For the semicircular cylinder CDE in Ex. 2.9, find the vertical hydrostatic force by integrating the vertical component of pressure around the surface from $\theta = 0$ to $\theta = \pi$.

Solution: A sketch is repeated here. At any position θ ,

as in Fig. P2.81, the vertical component of pressure is $p \cos \theta$. The depth down to this point is $h + R(1 - \cos \theta)$, and the local pressure is γ times this depth. Thus

$$F = \int p \cos \theta dA = \int_0^\pi \gamma [h + R(1 - \cos \theta)] (\cos \theta) [b R d\theta]$$

$$= \gamma b R (h + R) \int_0^\pi \cos \theta d\theta - \gamma b R^2 \int_0^\pi \cos^2 \theta d\theta = 0 - \gamma b R^2 \frac{\pi}{2}$$

$$\text{Rewrite: } F_{down} = -\gamma \frac{\pi}{2} R^2 b \quad \text{Ans.}$$

The negative sign occurs because the sign convention for dF was a *downward* force.

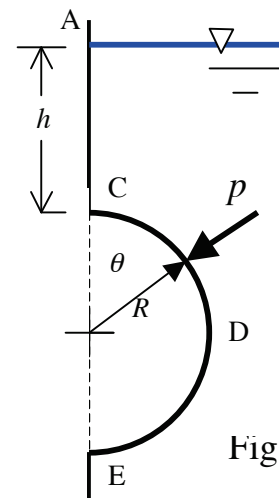

Fig. P2.81

P2.82 The dam in Fig. P2.82 is a quarter-circle 50 m wide into the paper. Determine the horizontal and vertical components of hydrostatic force against the dam and the point CP where the resultant strikes the dam.

Solution: The horizontal force acts as if the dam were vertical and 20 m high:

$$\begin{aligned} F_H &= \gamma h_{CG} A_{\text{vert}} \\ &= (9790 \text{ N/m}^3)(10 \text{ m})(20 \times 50 \text{ m}^2) \\ &= \mathbf{97.9 \text{ MN}} \quad \text{Ans.} \end{aligned}$$

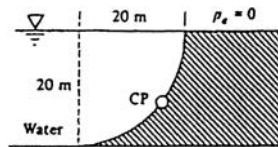
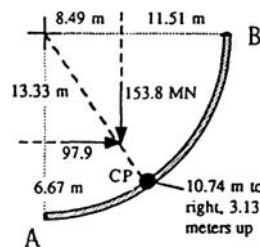

Fig. P2.82



This force acts $2/3$ of the way down or 13.33 m from the surface, as in the figure. The vertical force is the weight of the fluid above the dam:

$$F_V = \gamma(\text{Vol})_{\text{dam}} = (9790 \text{ N/m}^3) \frac{\pi}{4} (20 \text{ m})^2 (50 \text{ m}) = \mathbf{153.8 \text{ MN}} \quad \text{Ans.}$$

This vertical component acts through the centroid of the water above the dam, or $4R/3\pi = 4(20 \text{ m})/3\pi = 8.49 \text{ m}$ to the right of point A, as shown in the figure. The resultant hydrostatic force is $F = [(97.9 \text{ MN})^2 + (153.8 \text{ MN})^2]^{1/2} = \mathbf{182.3 \text{ MN}}$ acting down at an angle of $\mathbf{32.5^\circ}$ from the vertical. The line of action of F strikes the circular-arc dam AB at the center of pressure CP, which is $\mathbf{10.74 \text{ m to the right and } 3.13 \text{ m up from point A}}$, as shown in the figure. *Ans.*

P2.83 Gate AB is a quarter-circle 10 ft wide and hinged at B. Find the force F just sufficient to keep the gate from opening. The gate is uniform and weighs 3000 lbf.

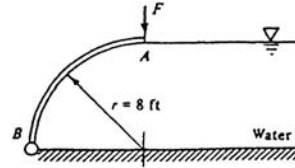

Fig. P2.83

Solution: The horizontal force is computed as if AB were vertical:

$$F_H = \gamma h_{CG} A_{\text{vert}} = (62.4)(4 \text{ ft})(8 \times 10 \text{ ft}^2) \\ = 19968 \text{ lbf} \quad \text{acting } 5.33 \text{ ft below A}$$

The vertical force equals the weight of the missing piece of water above the gate, as shown below.

$$F_V = (62.4)(8)(8 \times 10) - (62.4)(\pi/4)(8)^2(10) \\ = 39936 - 31366 = 8570 \text{ lbf}$$

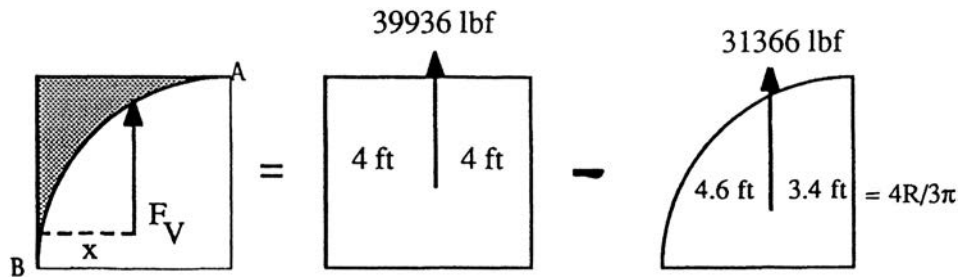
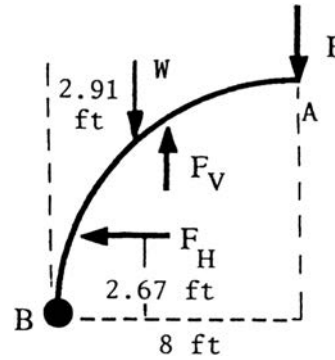

The line of action x for this 8570-lbf force is found by summing moments from above:

$$\sum M_B(\text{of } F_V) = 8570x = 39936(4.0) - 31366(4.605), \quad \text{or } x = 1.787 \text{ ft}$$

Finally, there is the 3000-lbf gate weight W , whose centroid is $2R/\pi = 5.093$ ft from force F , or $8.0 - 5.093 = 2.907$ ft from point B. Then we may sum moments about hinge B to find the force F , using the freebody of the gate as sketched at the top-right of this page:

$$\sum M_B(\text{clockwise}) = 0 = F(8.0) + (3000)(2.907) - (8570)(1.787) - (19968)(2.667), \\ \text{or } F = \frac{59840}{8.0} = \mathbf{7480 \text{ lbf}} \quad \text{Ans.}$$

P2.84 Panel AB is a parabola with its maximum at point A. It is 150 cm wide into the paper. Neglect atmospheric pressure. Find (a) the vertical and (b) horizontal water forces on the panel.

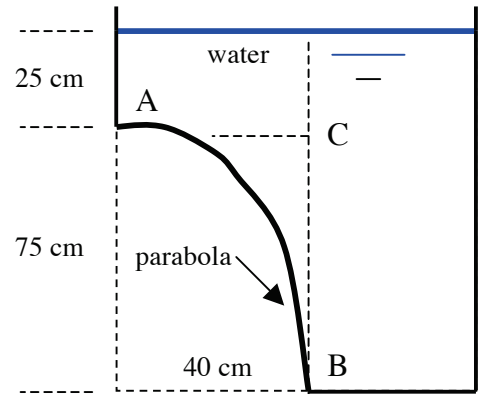

Fig. P2.84

Solution: (b) The horizontal force is calculated from the vertical projection of the panel (from point A down to the bottom). This is a rectangle, 75 cm by 150 cm, and its centroid is 37.5 cm below A, or $(25 + 37.5) = 62.5$ cm below the surface. Thus

$$F_H = p_{CG,H} A_{projected} = \left[9790 \frac{N}{m^3} (0.625m) \right] [0.75m(1.50m)] = \mathbf{6880 N} \quad \text{Ans.}(b)$$

(a) The vertical force is the weight of water above the panel. This is in two parts (1) the weight of the rectangular portion above the line AC; and (2) the little curvy piece above the parabola and below line AC. Recall from Ex. 2.8 that the area under a parabola is two-thirds of the enclosed rectangle, so that little curvy piece is *one-third* of the rectangle. Thus, finally,

$$\begin{aligned} F_V &= (9790)(0.25)(0.4)(1.5) + (9790)\left(\frac{1}{3}\right)(0.75)(0.4)(1.5) = \\ &= 1469 N + 1469 N \approx \mathbf{2940 N} \quad \text{Ans.}(a) \end{aligned}$$

P2.85 Compute the horizontal and vertical components of the hydrostatic force on the quarter-circle panel at the bottom of the water tank in Fig. P2.85.

Solution: The horizontal component is

$$\begin{aligned} F_H &= \gamma h_{CG} A_{\text{vert}} = (9790)(6)(2 \times 6) \\ &= \mathbf{705000 \text{ N}} \quad \text{Ans. (a)} \end{aligned}$$

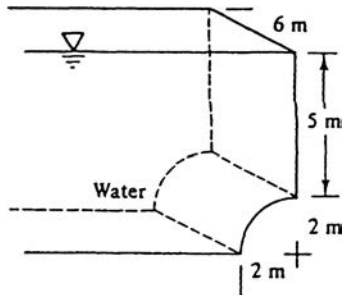

Fig. P2.85

The vertical component is the weight of the fluid above the quarter-circle panel:

$$\begin{aligned} F_V &= W(2 \text{ by } 7 \text{ rectangle}) - W(\text{quarter-circle}) \\ &= (9790)(2 \times 7 \times 6) - (9790)(\pi/4)(2)^2(6) \\ &= 822360 - 184537 = \mathbf{638000 \text{ N}} \quad \text{Ans. (b)} \end{aligned}$$

P2.86 The quarter circle gate BC in Fig. P2.86 is hinged at C. Find the horizontal force P required to hold the gate stationary. The width b into the paper is 3 m. Neglect the weight of the gate.

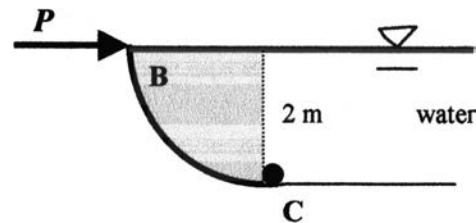

Fig. P2.86

Solution: The horizontal component of water force is

$$F_H = \gamma h_{CG} A = (9790 \text{ N/m}^3)(1 \text{ m})[(2 \text{ m})(3 \text{ m})] = 58,740 \text{ N}$$

This force acts $2/3$ of the way down or 1.333 m down from the surface (0.667 m up from C). The vertical force is the weight of the quarter-circle of water above gate BC:

$$F_V = \gamma (\text{Vol})_{\text{water}} = (9790 \text{ N/m}^3)[(\pi/4)(2 \text{ m})^2(3 \text{ m})] = 92,270 \text{ N}$$

F_V acts down at $(4R/3\pi) = 0.849$ m to the left of C. Sum moments clockwise about point C:

$$\sum M_C = 0 = (2 \text{ m})P - (58740 \text{ N})(0.667 \text{ m}) - (92270 \text{ N})(0.849 \text{ m}) = 2P - 117480$$

$$\text{Solve for } P = 58,700 \text{ N} = \mathbf{58.7 \text{ kN}} \quad \text{Ans.}$$

P2.87 The bottle of champagne (SG = 0.96) in Fig. P2.87 is under pressure as shown by the mercury manometer reading. Compute the net force on the 2-in-radius hemispherical end cap at the bottom of the bottle.

Solution: First, from the manometer, compute the gage pressure at section AA in the

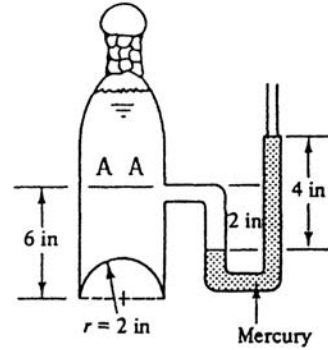

Fig. P2.87

champagne 6 inches above the bottom:

$$p_{AA} + (0.96 \times 62.4) \left(\frac{2}{12} \text{ ft} \right) - (13.56 \times 62.4) \left(\frac{4}{12} \text{ ft} \right) = p_{\text{atmosphere}} = 0 \text{ (gage)},$$

$$\text{or: } P_{AA} = 272 \text{ lbf/ft}^2 \text{ (gage)}$$

Then the force on the bottom end cap is vertical only (due to symmetry) and equals the force at section AA plus the weight of the champagne below AA:

$$\begin{aligned} F &= F_V = p_{AA}(\text{Area})_{AA} + W_{6\text{-in cylinder}} - W_{2\text{-in hemisphere}} \\ &= (272) \frac{\pi}{4} (4/12)^2 + (0.96 \times 62.4) \pi (2/12)^2 (6/12) - (0.96 \times 62.4) (2\pi/3) (2/12)^3 \\ &= 23.74 + 2.61 - 0.58 \approx \mathbf{25.8 \text{ lbf}} \quad \text{Ans.} \end{aligned}$$

P2.88 Circular-arc *Tainter* gate ABC pivots about point O. For the position shown, determine (a) the hydrostatic force on the gate (per meter of width into the paper); and (b) its line of action. Does the force pass through point O?

Solution: The horizontal hydrostatic force is based on vertical projection:

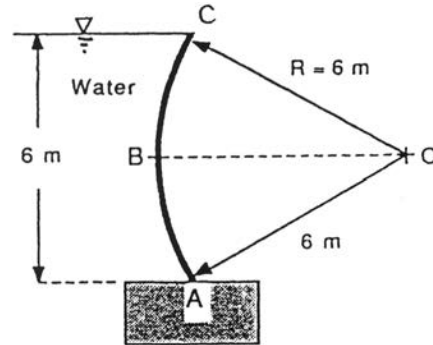
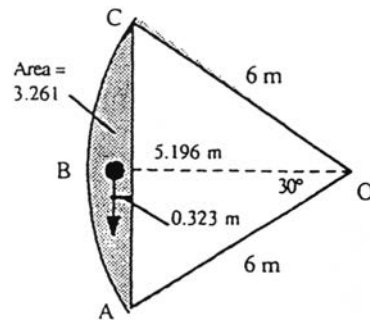

Fig. P2.88

$$F_H = \gamma h_{CG} A_{\text{vert}} = (9790)(3)(6 \times 1) = 176220 \text{ N} \quad \text{at 4 m below C}$$

The vertical force is *upward* and equal to the weight of the missing water in the segment ABC shown shaded below. Reference to a good handbook will give you the geometric properties of a circular segment, and you may compute that the segment area is 3.261 m^2 and its centroid is 5.5196 m from point O, or 0.3235 m from vertical line AC, as shown in the figure. The vertical (upward) hydrostatic force on gate ABC is thus



$$F_V = \gamma A_{ABC}(\text{unit width}) = (9790)(3.2611) \\ = 31926 \text{ N} \quad \text{at 0.4804 m from B}$$

The net force is thus $F = [F_H^2 + F_V^2]^{1/2} = \mathbf{179100 \text{ N}}$ per meter of width, acting upward to the right at an angle of $\mathbf{10.27^\circ}$ and passing through a point 1.0 m below and 0.4804 m to the right of point B. This force passes, as expected, *right through point O*.

P2.89 The tank in the figure contains benzene and is pressurized to 200 kPa (gage) in the air gap. Determine the vertical hydrostatic force on circular-arc section AB and its line of action.

Solution: Assume unit depth into the paper. The vertical force is the weight of benzene plus the force due to the air pressure:

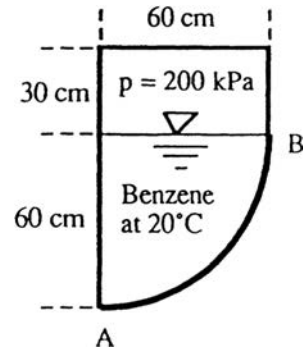

Fig. P2.89

$$F_V = \frac{\pi}{4}(0.6)^2(1.0)(881)(9.81) + (200,000)(0.6)(1.0) = 122400 \frac{\text{N}}{\text{m}} \quad \text{Ans.}$$

Most of this (120,000 N/m) is due to the air pressure, whose line of action is in the middle of the horizontal line through B. The vertical benzene force is 2400 N/m and has a line of action (see Fig. 2.13 of the text) at $4R/(3\pi) = 25.5$ cm to the right of A.

The moment of these two forces about A must equal to moment of the combined (122,400 N/m) force times a distance X to the right of A:

$$(120000)(30 \text{ cm}) + (2400)(25.5 \text{ cm}) = 122400(X), \quad \text{solve for } X = 29.9 \text{ cm} \quad \text{Ans}$$

The vertical force is **122400 N/m** (down), acting at **29.9 cm** to the right of A.

P2.90 The tank in Fig. P2.90 is 120 cm long into the paper. Determine the horizontal and vertical hydrostatic forces on the quarter-circle panel AB.

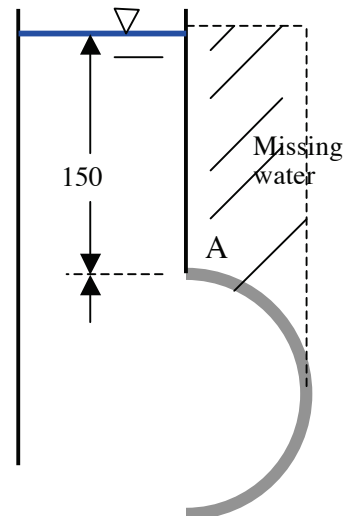

The fluid is water at 20°C.

Neglect atmospheric pressure.

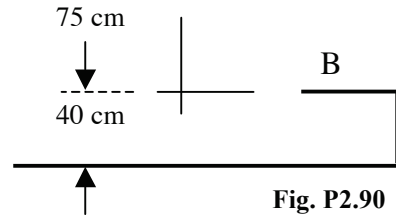

Solution: For water at 20°C, take $\gamma = 9790 \text{ N/m}^3$.

The vertical force on AB is the weight of the missing water above AB – see the dashed lines in Fig. P2.90. Calculate this as a rectangle plus a square-minus-a-quarter-circle:

$$\text{Missing water} = (1.5\text{m})(0.75\text{m})(1.2\text{m}) + (1 - \pi/4)(0.75\text{m})^2 = 2.16 + 0.145 = 2.305 \text{ m}^3$$

$$F_V = \gamma v = (9790 \text{ N/m}^3)(2.305 \text{ m}^3) = \mathbf{22,600 \text{ N}} \quad (\text{vertical force})$$

The horizontal force is calculated from the vertical projection of panel AB:

$$F_H = p_{CG} h A_{\text{projection}} = (9790 \frac{\text{N}}{\text{m}^3})(1.5 + \frac{0.75}{2} \text{ m})(0.75\text{m})(1.2\text{m}) = \mathbf{16,500 \text{ N}} \quad (\text{horizontal force})$$

P2.91 The hemispherical dome in Fig. P2.91 weighs 30 kN and is filled with water and attached to the floor by six equally-spaced bolts. What is the force in each bolt required to hold the dome down?

Solution: Assuming no leakage, the hydrostatic force required equals the *weight of missing water*, that is, the water in a 4-m-diameter cylinder, 6 m high, minus the hemisphere and the small pipe:

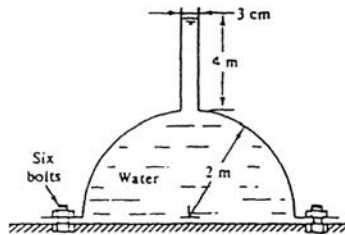

Fig. P2.91

$$\begin{aligned} F_{\text{total}} &= W_{2\text{-m-cylinder}} - W_{2\text{-m-hemisphere}} - W_{3\text{-cm-pipe}} \\ &= (9790)\pi(2)^2(6) - (9790)(2\pi/3)(2)^3 - (9790)(\pi/4)(0.03)^2(4) \\ &= 738149 - 164033 - 28 = 574088 \text{ N} \end{aligned}$$

The dome material helps with 30 kN of weight, thus the bolts must supply 574088–30000 or 544088 N. The force in each of 6 bolts is 544088/6 or $F_{\text{bolt}} \approx 90700 \text{ N}$ Ans.

P2.92 A 4-m-diameter water tank consists of two half-cylinders, each weighing 4.5 kN/m, bolted together as in Fig. P2.92. If the end caps are neglected, compute the force in each bolt.

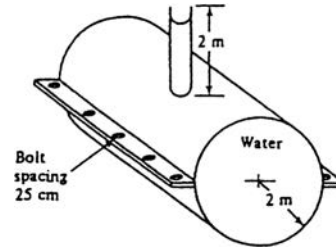

Fig. P2.92

Solution: Consider a 25-cm width of upper cylinder, as seen below. The water pressure in the bolt plane is

$$p_1 = \gamma h = (9790)(4) = 39160 \text{ Pa}$$

Then summation of vertical forces on this 25-cm-wide freebody gives

$$\begin{aligned} \sum F_z = 0 &= p_1 A_1 - W_{\text{water}} - W_{\text{tank}} - 2F_{\text{bolt}} \\ &= (39160)(4 \times 0.25) - (9790)(\pi/2)(2)^2 (0.25) \\ &\quad - (4500)/4 - 2F_{\text{bolt}}, \end{aligned}$$

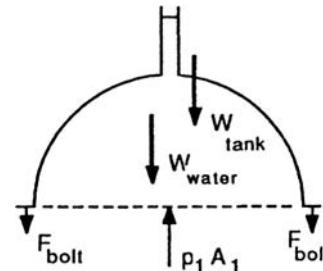

Solve for $F_{\text{one bolt}} = 11300 \text{ N}$ Ans.

P2.93 In Fig. P2.93 a one-quadrant spherical shell of radius R is submerged in liquid of specific weight γ and depth $h > R$. Derive an analytic expression for the hydrodynamic force F on the shell and its line of action.

force on the quarter-circle side panels, whose centroids are $(4R/3\pi)$ above the bottom:

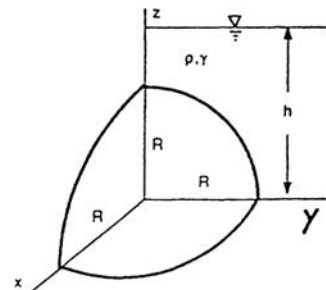

Solution: The two horizontal components are identical in magnitude and equal to the

Fig. P2.93

$$\text{Horizontal components: } F_x = F_y = \gamma h_{CG} A_{\text{vert}} = \gamma \left(h - \frac{4R}{3\pi} \right) \frac{\pi}{4} R^2$$

Similarly, the vertical component is the weight of the fluid above the spherical surface:

$$F_z = W_{\text{cylinder}} - W_{\text{sphere}} = \gamma \left(\frac{\pi}{4} R^2 h \right) - \gamma \left(\frac{1}{8} \frac{4}{3} \pi R^3 \right) = \gamma \frac{\pi}{4} R^2 \left(h - \frac{2R}{3} \right)$$

There is no need to find the (complicated) centers of pressure for these three components, for we know that the resultant on a spherical surface must pass through the center. Thus

$$F = \left[F_x^2 + F_y^2 + F_z^2 \right]^{1/2} = \gamma \frac{\pi}{4} R^2 \left[(h - 2R/3)^2 + 2(h - 4R/3\pi)^2 \right]^{1/2} \quad \text{Ans.}$$

P2.94 Find an analytic formula for the vertical and horizontal forces on each of the semi-circular panels AB in Fig. P2.94. The width into the paper is b . Which force is larger? Why?

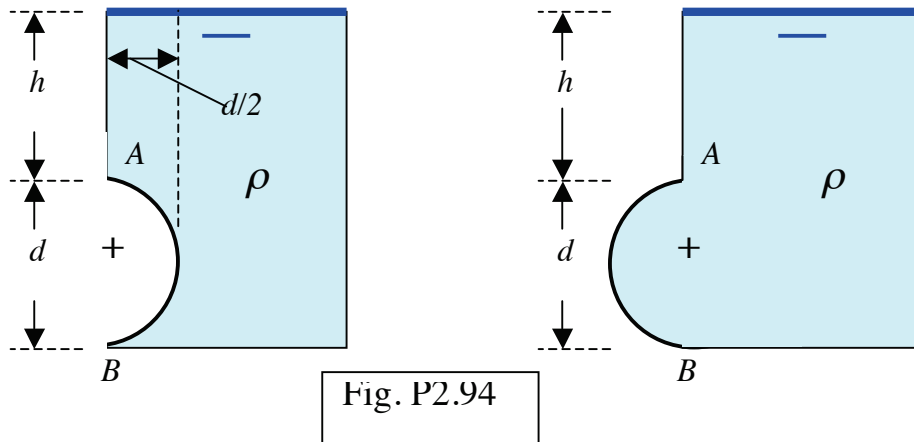

Fig. P2.94

Solution: It looks deceiving, since the bulging panel on the right has more water nearby, but these two forces are the same, except for their direction. The left-side figure is the same as Example 2.9, and its vertical force is *up*. The right-side figure has the

same vertical force, but it is *down*. Both vertical forces equal the weight of water inside, or displaced by, the half-cylinder AB. Their horizontal forces equal the force on the projected plane AB.

$$F_H = p_{CG,AB} A_{projected} = \left[\rho g \left(h + \frac{d}{2} \right) \right] (bd) \quad \text{Ans.}$$

$$F_V = \rho g v_{half-cylinder} = \rho g \left[\frac{\pi}{2} \left(\frac{d}{2} \right)^2 b \right] \quad \text{Ans.}$$

P2.95 The uniform body A in the figure has width b into the paper and is in static equilibrium when pivoted about hinge O. What is the specific gravity of this body when (a) $h = 0$; and (b) $h = R$?

Solution: The water causes a horizontal and a vertical force on the body, as shown:

$$F_H = \gamma \frac{R}{2} Rb \quad \text{at } \frac{R}{3} \text{ above } O,$$

$$F_V = \gamma \frac{\pi}{4} R^2 b \quad \text{at } \frac{4R}{3\pi} \text{ to the left of } O$$

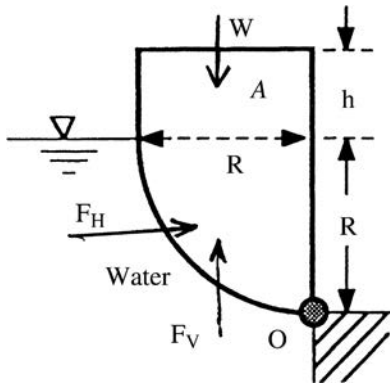

These must balance the moment of the body weight W about O:

$$\sum M_O = \frac{\gamma R^2 b}{2} \left(\frac{R}{3} \right) + \frac{\gamma \pi R^2 b}{4} \left(\frac{4R}{3\pi} \right) - \gamma_s \pi R^2 b \left(\frac{4R}{3\pi} \right) - \gamma_s R h b \left(\frac{R}{2} \right) = 0$$

$$\text{Solve for } SG_{body} = \frac{\gamma_s}{\gamma} = \left[\frac{2}{3} + \frac{h}{R} \right]^{-1} \quad \text{Ans}$$

For $h = 0$, $SG = 3/2$ Ans. (a). For $h = R$, $SG = 3/5$ Ans. (b).

P2.96 In Fig. P2.96 the curved section AB is 5 m wide into the paper and is a 60° circular arc of radius 2 m. Neglecting atmospheric pressure, calculate the vertical and horizontal hydrostatic forces on arc AB.

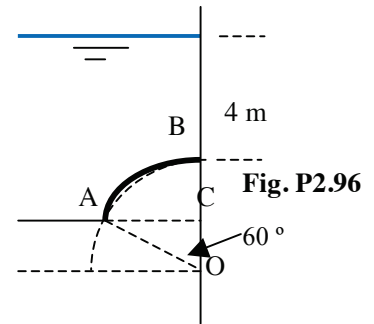

Solution: For water take $\gamma = 9790 \text{ N/m}^3$. Find the distances AC and BC:

$$AC = R \sin \theta = 2 \sin(60^\circ) = 1.732 \text{ m}; \quad BC = R - R \cos \theta = 2 - 2 \cos(60^\circ) = 1 \text{ m}$$

The horizontal force equals the force on panel BC:

$$F_H = \gamma h_{cg} A_{BC} = (9790 \text{ N/m}^3)(4 \text{ m} + 0.5 \text{ m})(0.5 \text{ m} \times 5 \text{ m}) = \mathbf{110,000 \text{ N}} \quad \text{Ans.}$$

For the vertical force, we need the area of segment ABC:

$$A_{ABC} = A_{ABO} - A_{AOC} = (\pi / 6)(2 \text{ m})^2 - (0.5)(0.5 \text{ m})(1.732 \text{ m}) = 2.094 - 0.866 = 1.228 \text{ m}^2$$

Then the vertical force is the weight of water above ABC:

$$F_V = \gamma(\text{area above } ABC)(b) = (9790)[4(1.732) - 1.228](5) = 9790(5.70)(5) = \mathbf{279,000 \text{ N}} \quad \text{Ans.}$$

P2.97 The contractor ran out of gunite mixture and finished the deep corner, of a

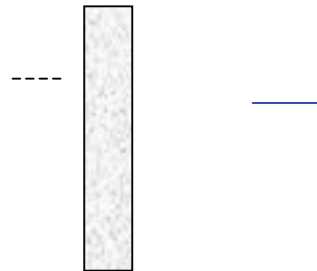

5-m-wide swimming pool, with a quarter-circle piece of PVC pipe, labeled AB in

Fig. P2.97. Compute the (a) horizontal and (b) vertical water forces on the curved panel AB.

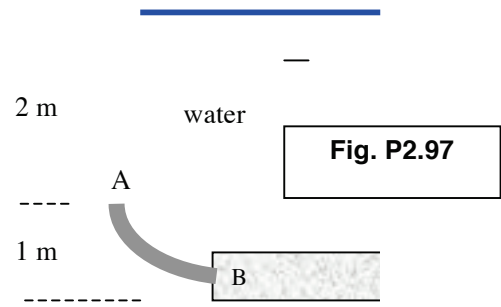

Solution: For water take $\gamma = 9790 \text{ N/m}^3$. (a) The horizontal force relates to the vertical projection of the curved panel AB:

$$F_{H,AB} = \gamma h_{CG} A_{projected} = (9790 \frac{\text{N}}{\text{m}^3})(2.5 \text{ m})[(1 \text{ m})(5 \text{ m})] = \mathbf{122,000 \text{ N}} \quad \text{Ans.(a)}$$

(b) The vertical force is the weight of water above panel AB:

$$F_V = (9790 \frac{\text{N}}{\text{m}^3})[(2 \text{ m})(1 \text{ m}) + \frac{\pi}{4}(1 \text{ m})^2](5 \text{ m}) = \mathbf{136,000 \text{ N}} \quad \text{Ans.(b)}$$

P2.98 The curved surface in Fig. P2.98

consists of two quarter-spheres and a half cylinder.

A side view and front view are shown.

Calculate the horizontal and vertical forces on the surface.

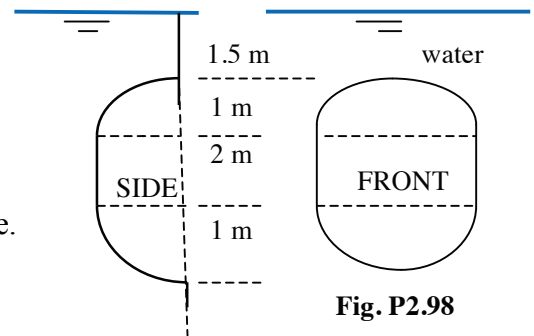

Solution: For water take $\gamma = 9790 \text{ N/m}^3$. The horizontal force involves the projected area, in the front view – two half-circles and a square:

$$A_{projected} = 2(\pi / 2)(1 \text{ m})^2 + (2 \text{ m})(2 \text{ m}) = 7.14 \text{ m}^2$$

The centroid depth is $h_{CG} = 1.5\text{m} + 1\text{m} + 1\text{m} = 3.5\text{ m}$. Then the horizontal force is

$$F_H = \gamma h_{CG} A_{\text{projected}} = (9790\text{ N/m}^3)(3.5\text{ m})(7.14\text{ m}^2) = \mathbf{245,000\text{ N}} \quad \text{Ans.}$$

By analogy with Example 2.9, the vertical force is the weight of water displaced by the projection:

$$Vol_{\text{displaced}} = 2\left[\frac{1}{4}\left(\frac{4}{3}\right)\pi(1\text{ m})^3\right] + \frac{1}{2}[\pi(1\text{ m})^2(2\text{ m})] = 2.09 + 3.14 = 5.24\text{ m}^3$$

$$\text{Then } F_V = \gamma(Vol) = (9790\text{ N/m}^3)(5.24\text{ m}^3) = \mathbf{51,000\text{ N}} \quad \text{Ans.}$$

P2.99 The mega-magnum cylinder in

Fig. P2.99 has a hemispherical bottom and is pressurized with air to 75 kPa (gage).

Determine (a) the horizontal and (b) the vertical hydrostatic forces on the hemisphere, in lbf.

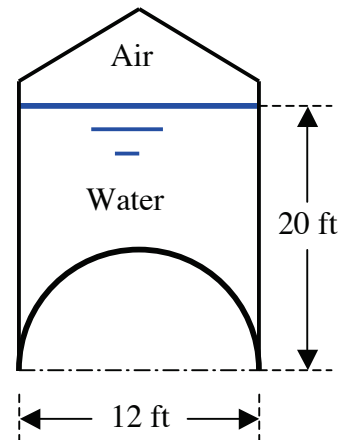

Fig. P2.99

Solution: Since the problem asks for BG units,

convert the air pressure to BG: $75,000\text{ Pa} \div 47.88 = 1566\text{ lbf/ft}^2$.

(a) By symmetry, the net horizontal force on the hemisphere is zero. *Ans.(a)*

(b) The vertical force is the sum of the air pressure term plus the weight of the water above:

$$\begin{aligned}
 F_V &= p_{air} A_{surface} + \gamma_{water} v_{water} = \\
 &= (1566 \frac{lb_f}{ft^2}) \pi (6 ft)^2 + (62.4 \frac{lb_f}{ft^3}) [\pi (6 ft)^2 (20 ft) - \frac{1}{2} (\frac{4\pi}{3}) (6 ft)^3] \\
 &= 177,000 lb_f + 113,000 lb_f = \mathbf{290,000 lb_f} \quad Ans.(b)
 \end{aligned}$$

P2.100 Pressurized water fills the tank in Fig. P2.100. Compute the hydrostatic force on the conical surface ABC.

Solution: The gage pressure is equivalent to a fictitious water level $h = p/\gamma = 150000/9790 = 15.32$ m above the gage or 8.32 m above AC. Then the vertical force on the cone equals the weight of fictitious water above ABC:

$$\begin{aligned}
 F_V &= \gamma Vol_{above} \\
 &= (9790) \left[\frac{\pi}{4} (2)^2 (8.32) + \frac{1}{3} \frac{\pi}{4} (2)^2 (4) \right] \\
 &= \mathbf{297,000 N} \quad Ans.
 \end{aligned}$$

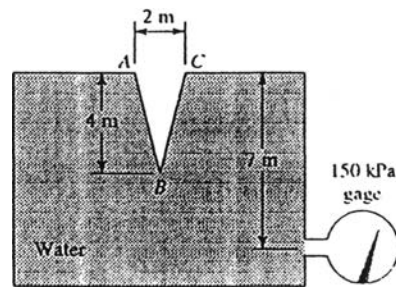
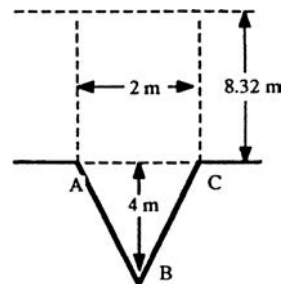

Fig. P2.100



P2.101 The closed layered box in Fig. P2.101

has square horizontal cross-sections everywhere.

All fluids are at 20°C. Estimate the

gage pressure of the air if (a) the

hydrostatic force on panel AB is 48 kN;

or if (b) the hydrostatic force on the

bottom panel BC is 97 kN.

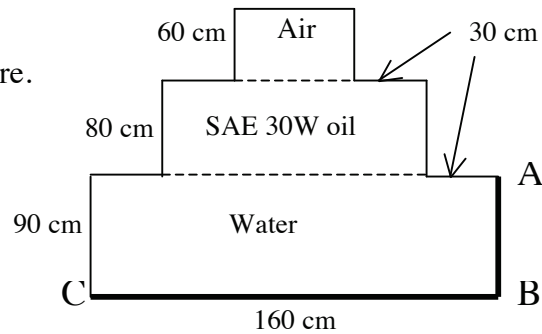

Fig. P2.101

Solution: At 20°C, take $\rho_{oil} = 891 \text{ kg/m}^3$ and $\rho_{water} = 998 \text{ kg/m}^3$. The wedding-cake shape of the box has nothing to do with the problem. (a) the force on panel AB equals the pressure at the panel centroid (45 cm down from A) times the panel area:

$$\begin{aligned}
 F_{AB} &= p_{CG} A_{AB} = (p_{air} + \rho_{oil} g h_{oil} + \rho_{water} g h_{water-CG}), \text{ or:} \\
 48000 \text{ N} &= [p_{air} + (891)(9.81)(0.8\text{m}) + (998)(9.81)(0.45\text{m})][(0.9\text{m})(1.6\text{m})] \\
 &= (p_{air} + 6993 + 4406 \text{ Pa})(1.44 \text{ m}^2); \text{ Solve } p_{air} = \mathbf{22000 \text{ Pa}} \quad \text{Ans.(a)}
 \end{aligned}$$

$$\begin{aligned}
 F_{BC} &= p_{BC} A_{BC} = (p_{air} + \rho_{oil} g h_{oil} + \rho_{water} g h_{water}), \text{ or:} \\
 97000 \text{ N} &= [p_{air} + (891)(9.81)(0.8\text{m}) + (998)(9.81)(0.9\text{m})][(1.6\text{m})(1.6\text{m})] \\
 &= (p_{air} + 6993 + 8812 \text{ Pa})(2.56 \text{ m}^2); \text{ Solve } p_{air} = \mathbf{22000 \text{ Pa}} \quad \text{Ans.(b)}
 \end{aligned}$$

(b) The force on the bottom is handled similarly, except we go all the way to the bottom:

P2.102 A cubical tank is $3 \times 3 \times 3$ m and is layered with 1 meter of fluid of specific gravity 1.0, 1 meter of fluid with $SG = 0.9$, and 1 meter of fluid with $SG = 0.8$. Neglect atmospheric pressure. Find (a) the hydrostatic force on the bottom; and (b) the force on a side panel.

Solution: (a) The force on the bottom is the bottom pressure times the bottom area:

$$F_{\text{bot}} = p_{\text{bot}} A_{\text{bot}} = (9790 \text{ N/m}^3)[(0.8 \times 1 \text{ m}) + (0.9 \times 1 \text{ m}) + (1.0 \times 1 \text{ m})](3 \text{ m})^2 \\ = \mathbf{238,000 \text{ N}} \quad \text{Ans. (a)}$$

(b) The hydrostatic force on the side panel is the sum of the forces due to each layer:

$$F_{\text{side}} = \sum \gamma h_{\text{CG}} A_{\text{side}} = (0.8 \times 9790 \text{ N/m}^3)(0.5 \text{ m})(3 \text{ m}^2) + (0.9 \times 9790 \text{ N/m}^3)(1.5 \text{ m})(3 \text{ m}^2) \\ + (9790 \text{ N/m}^3)(2.5 \text{ m})(3 \text{ m}^2) = \mathbf{125,000 \text{ kN}} \quad \text{Ans. (b)}$$

P2.103 A solid block, of specific gravity 0.9, floats such that 75% of its volume is in water and 25% of its volume is in fluid X, which is layered above the water. What is the specific gravity of fluid X?

Solution: The block is sketched below. A force balance is $W = \Sigma B$, or

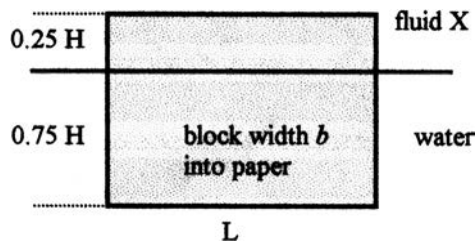

$$0.9\gamma(HbL) = \gamma(0.75HbL) + SG_X\gamma(0.25HbL)$$

$$0.9 - 0.75 = 0.25SG_X, \quad SG_X = \mathbf{0.6} \quad Ans.$$

P2.104 The can in Fig. P2.104 floats in the position shown. What is its weight in newtons?

Solution: The can weight simply equals the weight of the displaced water (neglecting the air above):

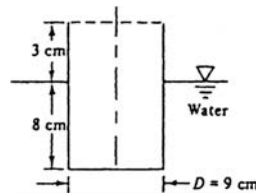

Fig. P2.104

$$W = \gamma v_{\text{displaced}} = (9790) \frac{\pi}{4} (0.09 \text{ m})^2 (0.08 \text{ m}) = \mathbf{5.0 \text{ N}} \quad Ans.$$

P2.105 Archimedes, when asked by King Hiero if the new crown was pure gold (SG = 19.3), found the crown weight in air to be 11.8 N and in water to be 10.9 N. Was it gold?

Solution: The buoyancy is the difference between air weight and underwater weight:

$$B = W_{\text{air}} - W_{\text{water}} = 11.8 - 10.9 = 0.9 \text{ N} = \gamma_{\text{water}} v_{\text{crown}}$$

$$\text{But also } W_{\text{air}} = (SG)\gamma_{\text{water}} v_{\text{crown}}, \quad \text{so } W_{\text{in water}} = B(SG - 1)$$

$$\text{Solve for } SG_{\text{crown}} = 1 + W_{\text{in water}}/B = 1 + 10.9/0.9 = \mathbf{13.1 \text{ (not pure gold)}} \quad Ans.$$

P2.106 A spherical helium balloon has a total mass of 3 kg. It settles in a calm standard atmosphere at an altitude of 5500 m. Estimate the diameter of the balloon.

Solution: From Table A.6, standard air density at 5500 m is 0.697 kg/m^3 . The balloon needs that same overall density to hover. Then the volume of the balloon is

$$Vol = \frac{mass}{density} = \frac{3.0 \text{ kg}}{0.697 \text{ kg/m}^3} = 4.30 \text{ m}^3 = (\pi/6)D^3, \text{ solve } D_{balloon} \approx \mathbf{2.0 \text{ m}} \text{ Ans.}$$

P2.107 Repeat Prob. P2.62 assuming that the 10,000 lbf weight is aluminum (SG = 2.71) and is hanging submerged in the water.

Solution: Refer back to Prob. P2.62 for details. The only difference is that the force applied to gate AB by the weight is less due to buoyancy:

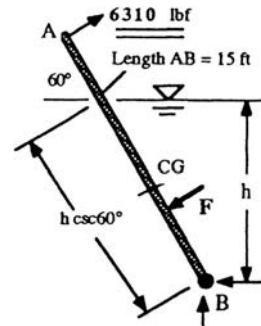

$$F_{net} = \frac{(SG-1)}{SG} \gamma v_{body} = \frac{2.71-1}{2.71} (10000) = 6310 \text{ lbf}$$

This force replaces “10000” in the gate moment relation (see Prob. P2.62):

$$\sum M_B = 0 = 6310(15) - (288.2h^2) \left(\frac{h}{2} \csc 60^\circ - \frac{h}{6} \csc 60^\circ \right) - 4898(7.5 \cos 60^\circ)$$

$$\text{or: } h^3 = 76280/110.9 = 688, \text{ or: } h = \mathbf{8.83 \text{ ft}} \text{ Ans.}$$

P2.108 A 7-cm-diameter solid aluminum ball (SG = 2.7) and a solid brass ball (SG = 8.5) balance nicely when submerged in a liquid, as in Fig. P2.108. (a) If the fluid is water at 20°C, what is the diameter of the brass ball? (b) If the

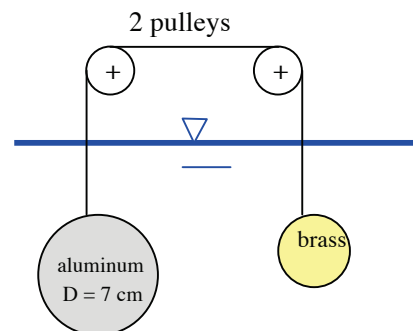

brass ball has a diameter of 3.8 cm, what is the density of the fluid?

Fig. P2.108

Solution: For water, take $\gamma = 9790 \text{ N/m}^3$. If they balance, net weights are equal:

$$(SG_{alum} - SG_{fluid})\gamma_{water} \frac{\pi}{6} D_{alum}^3 = (SG_{brass} - SG_{fluid})\gamma_{water} \frac{\pi}{6} D_{brass}^3$$

We can cancel γ_{water} and $(\pi/6)$. (a) For water, $SG_{fluid} = 1$, and we obtain

$$(2.7 - 1)(0.07 \text{ m})^3 = (8.5 - 1)D_{brass}^3 \quad ; \quad \text{Solve } D_{brass} = \mathbf{0.0427 \text{ m}} \quad \text{Ans.}(a)$$

(b) For this part, the fluid density (or specific gravity) is unknown:

$$(2.7 - SG_{fluid})(0.07 \text{ m})^3 = (8.5 - SG_{fluid})(0.038 \text{ m})^3 \quad ; \quad \text{Solve } SG_{fluid} = \mathbf{1.595}$$

$$\text{Thus } \rho_{fluid} = 1.595(998) = \mathbf{1592 \text{ kg/m}^3} \quad \text{Ans.}(b)$$

According to Table A3, this fluid is probably *carbon tetrachloride*.

2.109 The float level h of a hydrometer is a measure of the specific gravity of the liquid. For stem diameter D and total weight W , if $h = 0$ represents $SG = 1.0$, derive a formula for h as a function of W , D , SG , and γ_o for water.

Solution: Let submerged volume be v_o when $SG = 1$. Let $A = \pi D^2/4$ be the area of the stem. Then

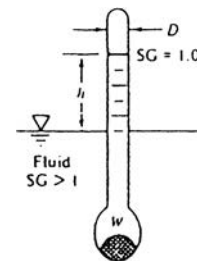

Fig. P2.109

$$W = \gamma_o v_o = (SG)\gamma_o(v_o - Ah), \quad \text{or:} \quad \mathbf{h} = \frac{W(SG - 1)}{SG\gamma_o(\pi D^2/4)} \quad \text{Ans.}$$

P2.110 A solid sphere, of diameter 18 cm, floats in 20°C water with 1,527 cubic centimeters exposed above the surface. (a) What are the weight and specific gravity of this sphere? (b) Will it float in 20°C gasoline? If so, how many cubic centimeters will be exposed?

Solution: The total volume of the sphere is $(\pi/6)(18 \text{ cm})^3 = 3054 \text{ cm}^3$. Subtract the exposed portion to find the submerged volume = $3054 - 1527 = 1527 \text{ cm}^3$. Therefore the sphere is floating exactly half in and half out of the water. (a) Its weight and specific gravity are

$$W_{\text{sphere}} = \rho_{\text{water}} g v_{\text{submerged}} = (998 \frac{\text{kg}}{\text{m}^3})(9.81 \frac{\text{m}}{\text{s}^2})(1527 \text{E} - 6 \text{m}^3) = \mathbf{14.95 \text{ N}} \quad \text{Ans.}(a)$$

$$\rho_{\text{sphere}} = \frac{W_{\text{sphere}}}{g v_{\text{sphere}}} = \frac{14.95}{(9.81)(3054 \text{E} - 6)} = 499 \frac{\text{kg}}{\text{m}^3}, \quad SG_{\text{sphere}} = \frac{499}{1000} \approx \mathbf{0.50} \quad \text{Ans.}(a)$$

(b) From Table A.3, $\rho_{\text{gasoline}} = 680 \text{ kg/m}^3 > \rho_{\text{sphere}}$. Therefore it **floats** in gasoline. *Ans.(b)*

(c) Neglecting air buoyancy on the exposed part, we compute the fraction of sphere volume that is exposed to be $(680 - 499 \text{ kg/m}^3)/(680 \text{ kg/m}^3) = 0.266$ or 26.6%. The volume exposed is

Check buoyancy: the submerged volume, 2241 cm^3 , times gasoline specific weight = 14.95 N ✓

$$v_{\text{exposed}} = 0.266 v_{\text{sphere}} = 0.266(3054 \text{ cm}^3) = \mathbf{813 \text{ cm}^3} \quad \text{Ans.}(c)$$

P2.111 A solid wooden cone (SG = 0.729) floats in water. The cone is 30 cm high, its vertex angle is 90°, and it floats with vertex down. How much of the cone protrudes above the water?

Solution: The cone must displace water equal

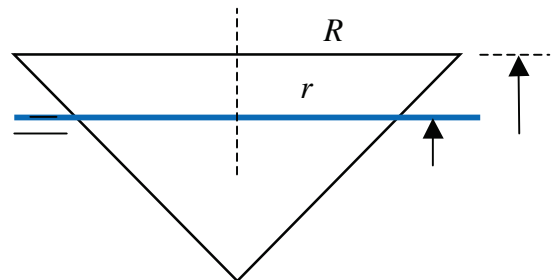

to its weight. Let the total height be H and the submerged height be h , as in the figure. The displaced water weight must equal the cone weight:

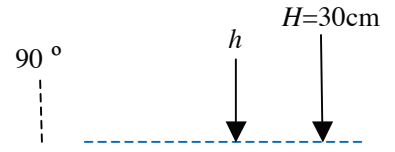

$$\gamma_{water} \frac{\pi}{3} r^2 h = [(\overline{SG})\gamma_{water}] \frac{\pi}{3} R^2 H; \quad \text{but } \frac{r}{h} = \frac{R}{H}$$

$$\text{Combine: } \frac{r^3}{R^3} = \frac{h^3}{H^3} = \overline{SG}, \quad \text{or: } h = H(\overline{SG})^{1/3} = (30\text{cm})(0.729)^{1/3} = 27\text{ cm}$$

Thus this cone protrudes above the water level by $H-h = 30\text{cm} - 27\text{cm} = \mathbf{3\text{ cm}}$ *Ans.*
We will find in Prob. P2.133 that this 90° cone is very stable and difficult to overturn.

P2.112 The uniform 5-m-long wooden rod in the figure is tied to the bottom by a string. Determine (a) the string tension; and (b) the specific gravity of the wood. Is it also possible to determine the inclination angle θ ?

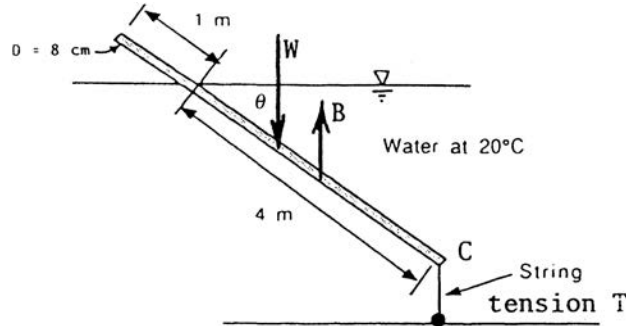

Fig. P2.112

Solution: The rod weight acts at the middle, 2.5 m from point C, while the buoyancy is 2 m from C. Summing moments about C gives

$$\sum M_C = 0 = W(2.5 \sin \theta) - B(2.0 \sin \theta), \quad \text{or} \quad W = 0.8B$$

$$\text{But} \quad B = (9790)(\pi/4)(0.08 \text{ m})^2(4 \text{ m}) = 196.8 \text{ N.}$$

$$\text{Thus} \quad W = 0.8B = 157.5 \text{ N} = \text{SG}(9790)(\pi/4)(0.08)^2(5 \text{ m}), \quad \text{or:} \quad \text{SG} \approx \mathbf{0.64} \quad \text{Ans. (b)}$$

Summation of vertical forces yields

$$\text{String tension} \quad T = B - W = 196.8 - 157.5 \approx \mathbf{39 \text{ N}} \quad \text{Ans. (a)}$$

These results are independent of the angle θ , which cancels out of the moment balance.

P2.113 A *spar buoy* is a rod weighted to float vertically, as in Fig. P2.113. Let the buoy be maple wood (SG = 0.6), 2 in by 2 in by 10 ft, floating in seawater (SG = 1.025). How many pounds of steel (SG = 7.85) should be added at the bottom so that $h = 18$ in?

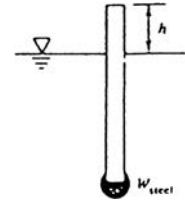

Fig. P2.113

Solution: The relevant volumes needed are

$$\text{Spar volume} = \frac{2}{12} \left(\frac{2}{12} \right) (10) = 0.278 \text{ ft}^3; \quad \text{Steel volume} = \frac{W_{\text{steel}}}{7.85(62.4)}$$

$$\text{Immersed spar volume} = \frac{2}{12} \left(\frac{2}{12} \right) (8.5) = 0.236 \text{ ft}^3$$

The vertical force balance is: buoyancy $B = W_{\text{wood}} + W_{\text{steel}}$,

$$\text{or: } 1.025(62.4) \left[0.236 + \frac{W_{\text{steel}}}{7.85(62.4)} \right] = 0.6(62.4)(0.278) + W_{\text{steel}}$$

$$\text{or: } 15.09 + 0.1306W_{\text{steel}} = 10.40 + W_{\text{steel}}, \quad \text{solve for } W_{\text{steel}} \approx \mathbf{5.4 \text{ lbf}} \quad \text{Ans.}$$

P2.114 The uniform rod in the figure is hinged at B and in static equilibrium when 2 kg of lead (SG = 11.4) are attached at its end. What is the specific gravity of the rod material? What is peculiar about the rest angle $\theta = 30^\circ$?

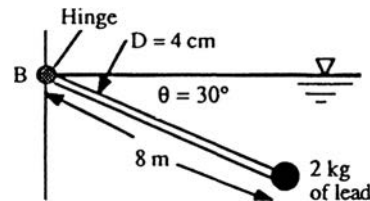

Solution: First compute buoyancies: $B_{\text{rod}} = 9790(\pi/4)(0.04)^2(8) = 98.42 \text{ N}$, and $W_{\text{lead}} = 2(9.81) = 19.62 \text{ N}$, $B_{\text{lead}} = 19.62/11.4 = 1.72 \text{ N}$. Sum moments about B:

$$\sum M_B = 0 = (SG - 1)(98.42)(4 \cos 30^\circ) + (19.62 - 1.72)(8 \cos 30^\circ) = 0$$

$$\text{Solve for } \mathbf{SG_{\text{rod}} = 0.636} \quad \text{Ans. (a)}$$

The angle θ drops out! The rod is neutrally stable for **any tilt angle!** Ans. (b)

P2.115 The 2 inch by 2 inch by 12 ft spar buoy from Fig. P2.113 has 5 lbm of steel attached and has gone aground on a rock. If the rock exerts no moments on the spar, compute the angle of inclination θ .

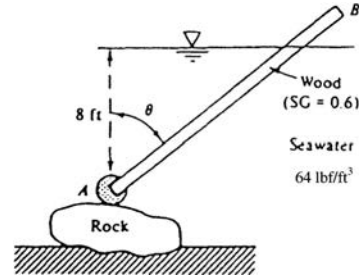

Solution: Let ζ be the submerged length of spar. The relevant forces are:

$$W_{\text{wood}} = (0.6)(64.0) \left(\frac{2}{12} \right) \left(\frac{2}{12} \right) (12) = 12.8 \text{ lbf} \quad \text{at distance } 6 \sin \theta \text{ to the right of } A \downarrow$$

$$\text{Buoyancy} = (64.0) \left(\frac{2}{12} \right) \left(\frac{2}{12} \right) \zeta = 1.778 \zeta \quad \text{at distance } \frac{\zeta}{2} \sin \theta \text{ to the right of } A \uparrow$$

The steel force acts right through A. Take moments about A:

$$\sum M_A = 0 = 12.8(6 \sin \theta) - 1.778 \zeta \left(\frac{\zeta}{2} \sin \theta \right)$$

$$\text{Solve for } \zeta^2 = 86.4, \quad \text{or } \zeta = 9.295 \text{ ft (submerged length)}$$

Thus the angle of inclination $\theta = \cos^{-1}(8.0/9.295) = \mathbf{30.6^\circ}$ Ans.

P2.116 A deep-ocean bathysphere is steel, $SG \approx 7.85$, with inside diameter 54 inches and wall thickness 1.5 inches. Will the empty sphere float in seawater?

Solution: Take the density of steel as $7.85(1000) = 7850 \text{ kg/m}^3$. The outside diameter is $54 + 2(1.5) = 57$ inches. Convert $D_o = 57 \text{ in} = 1.448 \text{ m}$ and $D_i = 54 \text{ in} = 1.372 \text{ m}$. The displaced weight is

$$W_{\text{displaced}} = \gamma_{\text{seawater}} Vol_{\text{displaced}} = (1.025)(9790)(\pi/6)(1.448)^3 = 15,950 \text{ N}$$

The weight of the steel sphere is

$$W_{\text{sphere}} = \gamma_{\text{steel}} Vol_{\text{steel}} = (7850)(9.81)(\pi/6)[(1.448)^3 - (1.372)^3] = 18,280 \text{ N}$$

We see that the empty sphere is 2,300 N heavier and **will not float in seawater.** Ans.

P2.117 The solid sphere in Fig. P2.117 is iron

(SG ≈ 7.9). The tension in the cable is 600 lbf.

Estimate the diameter of the sphere, in cm.

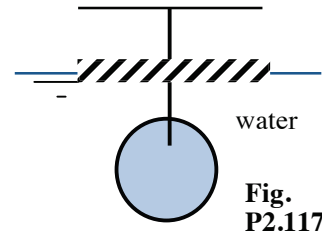

Solution: For water take $\gamma = 9790 \text{ N/m}^3$. Then the buoyant force and sphere weight are

$$B = \gamma_{\text{water}} (\pi/6) D^3 \quad \text{and} \quad W_{\text{sphere}} = 7.9B$$

The SI tension in the cable = $W - B = (7.9-1)(9790)(\pi/6) D^3 = 35,370 D^3 = 600 \text{ lbf} = 2670 \text{ N}$, with D in meters.

$$\text{Solve for } D = (2670/35370)^{1/3} = 0.42 \text{ m} = \mathbf{42 \text{ cm}} \quad \text{Ans.}$$

P2.118 An intrepid treasure-salvage group has discovered a steel box, containing gold doubloons and other valuables, resting in 80 ft of seawater. They estimate the weight of the box and treasure (in air) at 7000 lbf. Their plan is to attach the box to a sturdy balloon, inflated with air to 3 atm pressure. The empty balloon weighs 250 lbf. The box is 2 ft wide, 5 ft long, and 18 in high. What is the proper diameter of the balloon to ensure an upward lift force on the box that is 20% more than required?

Solution: The specific weight of seawater is approximately 64 lbf/ft^3 . The box volume is $(2\text{ft})(5\text{ft})(1.5\text{ft}) = 12 \text{ ft}^3$, hence the buoyant force on the box is $(64)(12) = 768 \text{ lbf}$. Thus the balloon must develop a net upward force of $1.2(7000-768\text{lbf}) = 7478 \text{ lbf}$. The air weight in the balloon is negligible, but we can compute it anyway. The air density is:

$$\text{At } p = 3 \text{ atm}, \rho_{\text{air}} = \frac{p}{RT} = \frac{3(2116 \text{ lbf} / \text{ft}^2)}{(1716 \text{ ft}^2 / \text{s}^2 - \circ R)(520 \circ R)} = 0.0071 \frac{\text{slug}}{\text{ft}^3}$$

Hence the air specific weight is $(0.0071)(32.2) = 0.23 \text{ lbf/ft}^3$, much less than the water. Accounting for balloon weight, the desired net buoyant force on the balloon is

$$F_{\text{net}} = (64 - 0.23 \text{ lbf} / \text{ft}^3)(\pi/6) D_{\text{balloon}}^3 - 250 \text{ lbf} = 7478 \text{ lbf}$$

$$\text{Solve for } D^3 = 231.4 \text{ lbf}^3, \quad D_{\text{balloon}} \approx \mathbf{6.14 \text{ ft}} \quad \text{Ans.}$$

P2.119 With a 5-lbf-weight placed at one end, the uniform wooden beam in the figure floats at an angle θ with its upper right corner at the surface. Determine (a) θ ; (b) γ_{wood} .

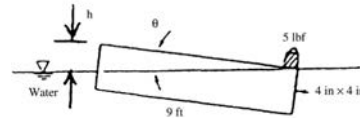

Fig. P2.119

Solution: The total wood volume is $(4/12)^2(9) = 1 \text{ ft}^3$. The exposed distance $h = 9 \tan \theta$. The vertical forces are

$$\sum F_z = 0 = (62.4)(1.0) - (62.4)(h/2)(9)(4/12) - (SG)(62.4)(1.0) - 5 \text{ lbf}$$

The moments of these forces about point C at the right corner are:

$$\sum M_C = 0 = \gamma(1)(4.5) - \gamma(1.5h)(6 \text{ ft}) - (SG)(\gamma)(1)(4.5 \text{ ft}) + (5 \text{ lbf})(0 \text{ ft})$$

where $\gamma = 62.4 \text{ lbf/ft}^3$ is the specific weight of water. Clean these two equations up:

$$1.5h = 1 - SG - 5/\gamma \quad (\text{forces}) \quad 2.0h = 1 - SG \quad (\text{moments})$$

Solve simultaneously for $SG \approx \mathbf{0.68}$ *Ans.* (b); $h = 0.16 \text{ ft}$; $\theta \approx \mathbf{1.02^\circ}$ *Ans.* (a)

P2.120 A uniform wooden beam (SG = 0.65) is 10 cm by 10 cm by 3 m and hinged at A. At what angle will the beam float in 20°C water?

Solution: The total beam volume is $3(0.1)^2 = 0.03 \text{ m}^3$, and therefore its weight is $W = (0.65)(9790)(0.03) = 190.9 \text{ N}$, acting at the centroid, 1.5 m down from point A. Meanwhile, if the submerged length is H, the buoyancy is $B = (9790)(0.1)^2 H = 97.9H$ newtons, acting at $H/2$ from the lower end. Sum moments about point A:

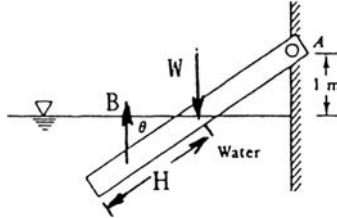

Fig. P2.120

$$\sum M_A = 0 = (97.9H)(3.0 - H/2) \cos \theta - 190.9(1.5 \cos \theta),$$

$$\text{or: } H(3 - H/2) = 2.925, \text{ solve for } H \approx 1.225 \text{ m}$$

Geometry: $3 - H = 1.775 \text{ m}$ is out of the water, or: $\sin \theta = 1.0/1.775$, or $\theta \approx 34.3^\circ$ Ans.

P2.121 The uniform beam in the figure is of size L by h by b, with $b, h \ll L$. A uniform heavy sphere tied to the left corner causes the beam to float exactly on its diagonal. Show that this condition requires (a) $\gamma_b = \gamma/3$; and (b) $D = [Lhb/\{\pi(SG - 1)\}]^{1/3}$.

$\gamma_b Lhb/2$ and acts at $L/3$ from the left corner. Sum moments about the left corner, point C:

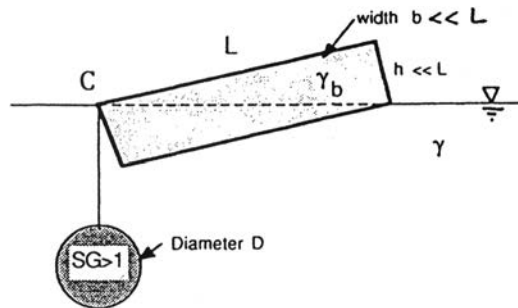

Fig. P2.121

$$\sum M_C = 0 = (\gamma_b Lhb)(L/2) - (\gamma Lhb/2)(L/3), \text{ or: } \gamma_b = \gamma/3 \text{ Ans. (a)}$$

Then summing vertical forces gives the required string tension T on the left corner:

$$\sum F_z = 0 = \gamma Lbh/2 - \gamma_b Lbh - T, \text{ or } T = \gamma Lbh/6 \text{ since } \gamma_b = \gamma/3$$

$$\text{But also } T = (W - B)_{\text{sphere}} = (SG - 1)\gamma \frac{\pi}{6} D^3, \text{ so that } D = \left[\frac{Lhb}{\pi(SG - 1)} \right]^{1/3} \text{ Ans. (b)}$$

P2.122 A uniform block of steel (SG = 7.85) will “float” at a mercury-water interface as in the figure. What is the ratio of the distances a and b for this condition?

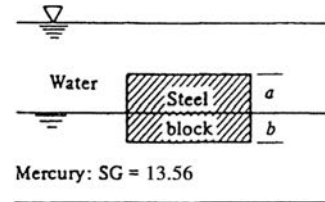

Fig. P2.122

Solution: Let w be the block width into the paper and let γ be the water specific weight. Then the vertical force balance on the block is

$$7.85\gamma(a + b)Lw = 1.0\gamma aLw + 13.56\gamma bLw,$$

$$\text{or: } 7.85a + 7.85b = a + 13.56b, \quad \text{solve for } \frac{a}{b} = \frac{13.56 - 7.85}{7.85 - 1} = \mathbf{0.834} \quad \text{Ans.}$$

P2.123 A barge has the trapezoidal

shape shown in Fig. P2.123 and is 22 m long into the paper.

If the total weight of barge and cargo is 350 tons, what is the draft

H of the barge when floating in seawater?

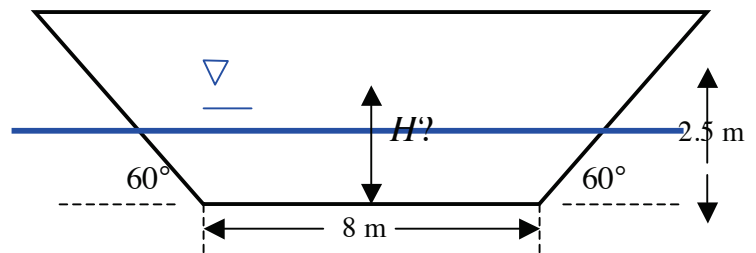

Fig. P2.123

Solution: For seawater, let $\rho = 1025 \text{ kg/m}^3$. The top of the barge has length $[8\text{m} + 2(2.5)/\tan 60^\circ] = 8 + 2.89 = 10.89 \text{ m}$. Thus the total volume of the barge is $[(8 + 10.89\text{m})/2](2.5\text{m})(22\text{m}) = 519.4 \text{ m}^3$. In terms of seawater, this total volume would be equivalent to $(519.4\text{m}^3)(1025\text{kg/m}^3)(9.81\text{m/s}^2) = 5.22\text{E}6\text{N} \div 4.4482\text{lbf/N} \div 2000\text{lbf/ton} = 587 \text{ tons}$. Thus a cargo of 350 tons = 700,000 lbf would fill the barge a bit more than halfway. Thus we solve the following equation for the draft to give $W = 350 \text{ tons}$:

$$(22m)(H)\left(8 + \frac{H}{\tan 60^\circ}m\right)\left(1025 \frac{\text{kg}}{\text{m}^3}\right)\left(9.81 \frac{\text{m}}{\text{s}^2}\right)\left(\frac{1}{4.4482 \text{ lbf} / \text{N}}\right) = 700,000 \text{ lbf}$$

Solve by iteration or EES: $H \approx 1.58 \text{ m}$ *Ans.*

P2.124 A balloon weighing 3.5 lbf is 6 ft in diameter. If filled with hydrogen at 18 psia and 60°F and released, at what U.S. standard altitude will it be neutral?

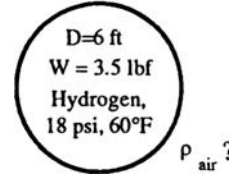

Solution: Assume that it remains at 18 psia and 60°F. For hydrogen, from Table A-4, $R \approx 24650 \text{ ft}^2/(\text{s}^2 \cdot \text{R})$. The density of the hydrogen in the balloon is thus

$$\rho_{\text{H}_2} = \frac{p}{RT} = \frac{18(144)}{(24650)(460 + 60)} \approx 0.000202 \text{ slug/ft}^3$$

In the vertical force balance for neutral buoyancy, only the outside air density is unknown:

$$\sum F_z = B_{\text{air}} - W_{\text{H}_2} - W_{\text{balloon}} = \rho_{\text{air}}(32.2)\frac{\pi}{6}(6)^3 - (0.000202)(32.2)\frac{\pi}{6}(6)^3 - 3.5 \text{ lbf}$$

$$\text{Solve for } \rho_{\text{air}} \approx 0.00116 \text{ slug/ft}^3 \approx 0.599 \text{ kg/m}^3$$

From Table A-6, this density occurs at a standard altitude of **6850 m \approx 22500 ft.** *Ans.*

P2.125 A uniform cylindrical white oak log, $\rho = 710 \text{ kg/m}^3$, floats lengthwise in fresh water at 20°C. Its diameter is 24 inches. What height of the log is visible above the surface?

Solution: The ratio of densities is $710/998 = 0.711$. Thus $1 - 0.711 = 0.289$, or 28.9% of the log's cross-section area protrudes above the surface. The relevant formulas

can be found online, or you can find them from the figure:

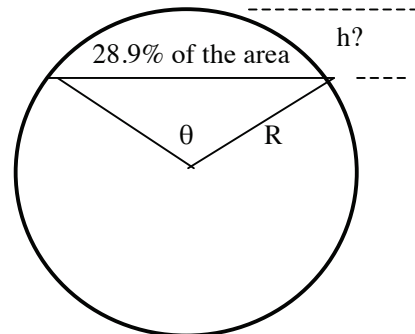

$$A_{\text{segment}} = (R^2 / 2)[\pi\theta/180 - \sin(\theta)], \quad \text{with } \theta \text{ in degrees}$$

$$h / R = 1 - \cos(\theta / 2)$$

We find θ such that $A_{\text{segment}}/A_{\text{circle}} = 0.289$, where, of course, $A_{\text{circle}} = \pi R^2$. You can find θ by iteration, knowing that it is of the order of 100° , or Excel will rapidly iterate to the answer, which is:

$$A_{\text{segment}} / (\pi R^2) = 0.289 \quad \text{when } \theta = 140.5^\circ, \text{ and } h / R = 0.662, \quad h = 0.662(12 \text{ in}) = 7.94 \text{ inches} \quad \text{Ans.}$$

P2.126 A block of wood (SG = 0.6) floats in fluid X in Fig. P2.126 such that 75% of its volume is submerged in fluid X. Estimate the gage pressure of the air in the tank.

Solution: In order to apply the hydrostatic relation for the air pressure calculation, the density of Fluid X must be found. The buoyancy principle is thus first applied. Let the block have volume V . Neglect the buoyancy of the air on the upper part of the block. Then

$$0.6\gamma_{\text{water}} V = \gamma_X(0.75V) + \gamma_{\text{air}}(0.25V); \quad \gamma_X \approx 0.8\gamma_{\text{water}} = 7832 \text{ N/m}^3$$

The air gage pressure may then be calculated by jumping from the left interface into fluid X:

$$0 \text{ Pa-gage} - (7832 \text{ N/m}^3)(0.4 \text{ m}) = p_{\text{air}} = -3130 \text{ Pa-gage} = \mathbf{3130 \text{ Pa-vacuum}} \quad \text{Ans.}$$

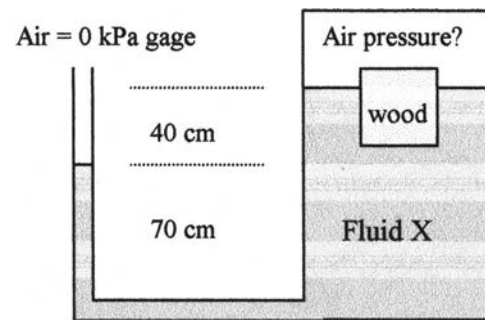

Fig. P2.126

P2.127* Consider a cylinder of specific gravity $S < 1$ floating vertically in water ($S = 1$), as in Fig. P2.127. Derive a formula for the stable values of D/L as a function of S and apply it to the case $D/L = 1.2$.

Solution: A vertical force balance provides a relation for h as a function of S and L ,

$$\gamma\pi D^2 h / 4 = S\gamma\pi D^2 L / 4, \quad \text{thus } h = SL$$

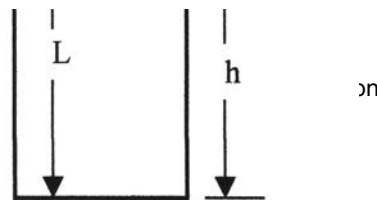

Fig. P2.127

To compute stability, we turn Eq. (2.52), centroid G , metacenter M , center of buoyancy B :

$$MB = I_o/v_{\text{sub}} = \frac{\frac{\pi}{4}(D/2)^4}{\frac{\pi}{4}D^2h} = MG + GB \quad \text{and substituting } h = SL, \quad \frac{D^2}{16SL} = MG + GL$$

where $GB = L/2 - h/2 = L/2 - SL/2 = L(1 - S)/2$. For neutral stability, $MG = 0$. Substituting,

$$\frac{D^2}{16SL} = 0 + \frac{L}{2}(1 - S) \quad \text{solving for } D/L, \quad \frac{D}{L} = \sqrt{8S(1 - S)} \quad \text{Ans}$$

If $D/L = 1.2$, $S^2 - S + 0.18 = 0$, or $0 \leq S \leq 0.235$ and $0.765 \leq S \leq 1$ for stability Ans.

P2.128 The iceberg of Fig. P2.20 can be idealized as a cube of side length L as shown. If seawater is denoted as $S = 1$, the iceberg has $S = 0.88$. Is it stable?

Solution: The distance h is determined by

$$\gamma_w h L^2 = S \gamma_w L^3, \quad \text{or: } h = SL$$

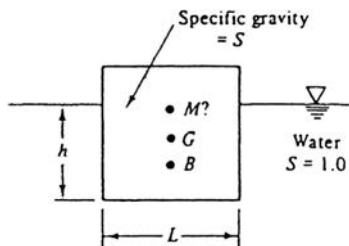

Fig. P2.128

The center of gravity is at $L/2$ above the bottom, and B is at $h/2$ above the bottom. The metacenter position is determined by Eq. (2.52):

$$MB = I_o/v_{\text{sub}} = \frac{L^4/12}{L^2h} = \frac{L^2}{12h} = \frac{L}{12S} = MG + GB$$

Noting that $GB = L/2 - h/2 = L(1 - S)/2$, we may solve for the metacentric height:

$$MG = \frac{L}{12S} - \frac{L}{2}(1 - S) = 0 \quad \text{if} \quad S^2 - S + \frac{1}{6} = 0, \quad \text{or:} \quad S = 0.211 \quad \text{or} \quad 0.789$$

Instability: $0.211 < S < 0.789$. Since the iceberg has $S = 0.88 > 0.789$, **it is stable.** *Ans.*

P2.129 The iceberg of Prob. P2.128 may become unstable if its width decreases. Suppose that the height is L and the depth into the paper is L but the width decreases to $H < L$. Again with $S = 0.88$ for the iceberg, determine the ratio H/L for which the iceberg becomes unstable.

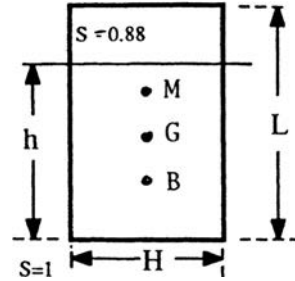

Solution: As in Prob. P2.128, the submerged distance $h = SL = 0.88L$, with G at $L/2$ above the bottom and B at $h/2$ above the bottom. From Eq. (2.52), the distance MB is

$$MB = \frac{I_o}{v_{\text{sub}}} = \frac{LH^3/12}{HL(SL)} = \frac{H^2}{12SL} = MG + GB = MG + \left(\frac{L}{2} - \frac{SL}{2} \right)$$

Then neutral stability occurs when $MG = 0$, or

$$\frac{H^2}{12SL} = \frac{L}{2}(1 - S), \quad \text{or} \quad \frac{H}{L} = [6S(1 - S)]^{1/2} = [6(0.88)(1 - 0.88)]^{1/2} = \mathbf{0.796} \quad \text{Ans.}$$

P2.130 Consider a wooden cylinder ($SG = 0.6$) 1 m in diameter and 0.8 m long. Would this cylinder be stable if placed to float with its axis vertical in oil ($SG = 0.85$)?

Solution: A vertical force balance gives

$$0.85\pi R^2 h = 0.6\pi R^2 (0.8 \text{ m}),$$

or: $h = 0.565 \text{ m}$

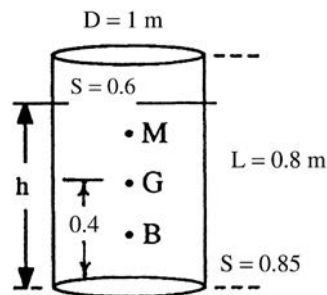

The point B is at $h/2 = 0.282$ m above the bottom. Use Eq. (2.52) to predict the meta-center location:

$$MB = I_o/v_{\text{sub}} = [\pi(0.5)^4/4]/[\pi(0.5)^2(0.565)] = 0.111 \text{ m} = MG + GB$$

Now $GB = 0.4 \text{ m} - 0.282 \text{ m} = 0.118 \text{ m}$, hence $MG = 0.111 - 0.118 = -0.007 \text{ m}$. This float position is thus **slightly unstable**. The cylinder would turn over. *Ans.*

P2.131 A barge is 15 ft wide and floats with a draft of 4 ft. It is piled so high with gravel that its center of gravity is 3 ft above the waterline, as shown. Is it stable?

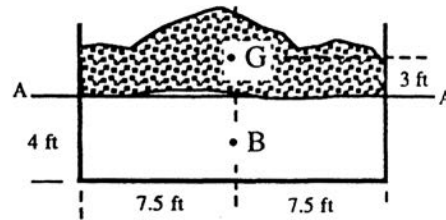

Solution: Example 2.10 applies to this case, with $L = 7.5$ ft and $H = 4$ ft:

$$MA = \frac{L^2}{3H} - \frac{H}{2} = \frac{(7.5 \text{ ft})^2}{3(4 \text{ ft})} - \frac{4 \text{ ft}}{2} = 2.69 \text{ ft}, \text{ where "A" is the waterline}$$

Since G is 3 ft above the waterline, $MG = 2.69 - 3.0 = -0.31 \text{ ft}$, **unstable**. *Ans.*

P2.132 A solid right circular cone has $SG = 0.99$ and floats vertically as shown. Is this a stable position?

Solution: Let r be the radius at the surface and let z be the exposed height. Then

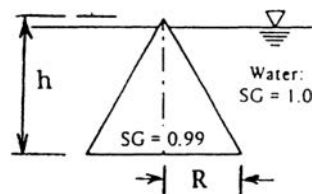

Fig. P2.132

$$\sum F_z = 0 = \gamma_w \frac{\pi}{3} (R^2 h - r^2 z) - 0.99 \gamma_w \frac{\pi}{3} R^2 h, \quad \text{with } \frac{z}{h} = \frac{r}{R}.$$

$$\text{Thus } \frac{z}{h} = (0.01)^{1/3} = 0.2154$$

The cone floats at a draft $\zeta = h - z = 0.7846h$. The centroid G is at $0.25h$ above the bottom. The center of buoyancy B is at the centroid of a frustrum of a (submerged) cone:

$$\zeta = \frac{0.7846h}{4} \left(\frac{R^2 + 2Rr + 3r^2}{R^2 + Rr + r^2} \right) = 0.2441h \quad \text{above the bottom}$$

Then Eq. (2.52) predicts the position of the metacenter:

$$\begin{aligned} MB &= \frac{I_o}{v_{\text{sub}}} = \frac{\pi(0.2154R)^4/4}{0.99\pi R^2 h} = 0.000544 \frac{R^2}{h} = MG + GB \\ &= MG + (0.25h - 0.2441h) = MG + 0.0594h \end{aligned}$$

Thus $MG > 0$ (**stability**) if $(R/h)^2 \geq 10.93$ or $R/h \geq 3.31$ *Ans.*

P2.133 Consider a uniform right circular cone of specific gravity $S < 1$, floating with its vertex down in water, $S = 1.0$. The base radius is R and the cone height is H , as shown. Calculate and plot the stability parameter MG of this cone, in dimensionless form, versus H/R for a range of cone specific gravities $S < 1$.

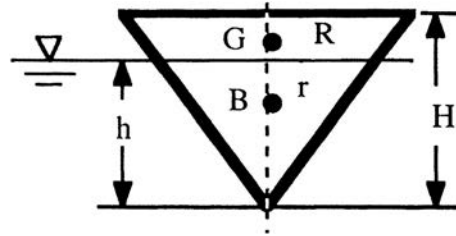

Solution: The cone floats at height h and radius r such that $B = W$, or:

$$\frac{\pi}{3} r^2 h (1.0) = \frac{\pi}{3} R^2 H (S), \quad \text{or: } \frac{h^3}{H^3} = \frac{r^3}{R^3} = S < 1$$

Thus $r/R = h/H = S^{1/3} = \zeta$ for short. Now use the stability relation:

$$MG + GB = MG + \left(\frac{3H}{4} - \frac{3h}{4} \right) = \frac{I_o}{v_{\text{sub}}} = \frac{\pi r^4/4}{\pi r^2 h/3} = \frac{3\zeta R^2}{4H}$$

$$\text{Non-dimensionalize in the final form: } \frac{MG}{H} = \frac{3}{4} \left(\zeta \frac{R^2}{H^2} - 1 + \zeta \right), \quad \zeta = S^{1/3} \quad \text{Ans.}$$

This is plotted below. Floating cones pointing *down* are stable unless slender, $R \ll H$.

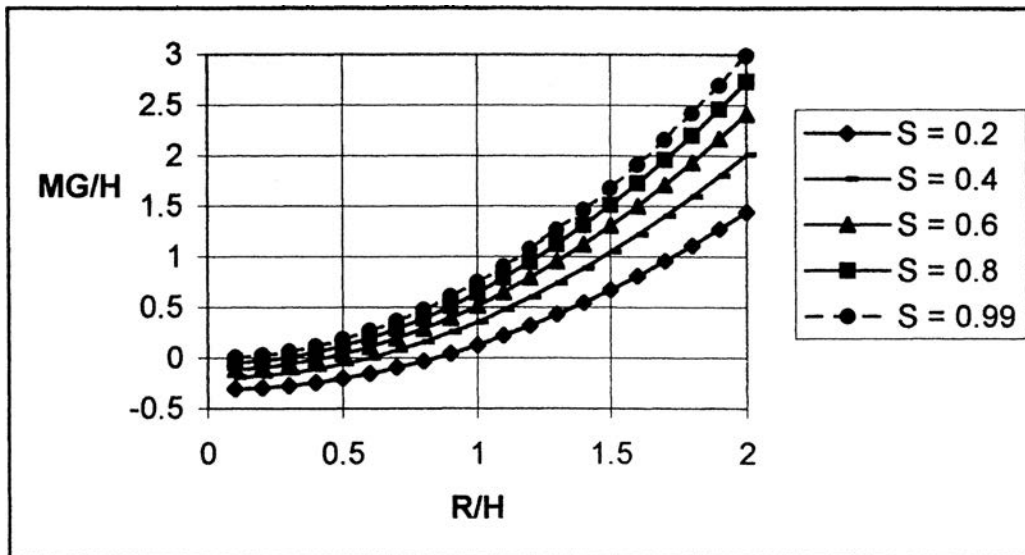

P2.134 When floating in water ($SG = 1$), an equilateral triangular body ($SG = 0.9$) might take *two* positions, as shown at right. Which position is more stable? Assume large body width into the paper.

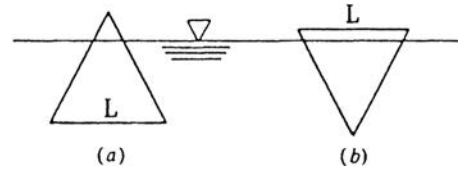

Fig. P2.134

Solution: The calculations are similar to the floating cone of Prob. P2.132. Let the triangle be L by L by L . List the basic results.

(a) Floating with point *up*: Centroid G is $0.289L$ above the bottom line, center of buoyancy B is $0.245L$ above the bottom, hence $GB = (0.289 - 0.245)L \approx 0.044L$. Equation (2.52) gives

$$MB = I_o/v_{\text{sub}} = 0.0068L = MG + GB = MG + 0.044L$$

Hence $MG = -0.037L$ **Unstable** *Ans. (a)*

(b) Floating with point *down*: Centroid G is $0.577L$ above the bottom point, center of buoyancy B is $0.548L$ above the bottom point, hence $GB = (0.577 - 0.548)L \approx 0.0296L$. Equation (2.52) gives

$$MB = I_o/v_{\text{sub}} = 0.1826L = MG + GB = MG + 0.0296L$$

Hence $MG = +0.153L$ **Stable** *Ans. (b)*

P2.135 Consider a homogeneous right circular cylinder of length L , radius R , and specific gravity SG , floating in water ($SG = 1$) with its axis *vertical*. Show that the body is stable if

$$R/L > [2SG(1 - SG)]^{1/2}$$

Solution: For a given SG , the body floats with a draft equal to $(SG)L$, as shown. Its center of gravity G is at $L/2$ above the bottom. Its center of buoyancy B is at $(SG)L/2$ above the bottom. Then Eq. (2.52) predicts the metacenter location:

$$MB = I_o/v_{\text{sub}} = \frac{\pi R^4/4}{\pi R^2(SG)L} = \frac{R^2}{4(SG)L} = MG + GB = MG + \frac{L}{2} - SG \frac{L}{2}$$

Thus $MG > 0$ (stability) if $R^2/L^2 > 2SG(1 - SG)$ *Ans.*

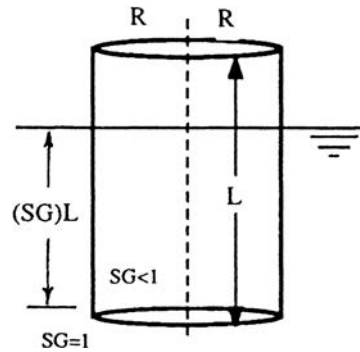

For example, if $SG = 0.8$, stability requires that $R/L > 0.566$.

P2.136 Consider a homogeneous right circular cylinder of length L , radius R , and specific gravity $SG = 0.5$, floating in water ($SG = 1$) with its axis *horizontal*. Show that the body is stable if $L/R > 2.0$.

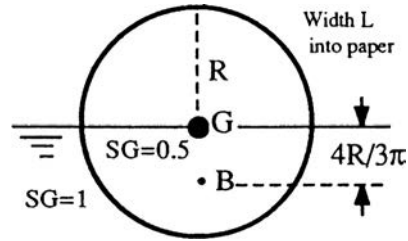

Solution: For the given $SG = 0.5$, the body floats centrally with a draft equal to R , as shown. Its center of gravity G is exactly at the surface. Its center of buoyancy B is at the centroid of the immersed semicircle: $4R/(3\pi)$ below the surface. Equation (2.52) predicts the metacenter location:

$$MB = I_o/v_{\text{sub}} = \frac{(1/12)(2R)L^3}{\pi(R^2/2)L} = \frac{L^2}{3\pi R} = MG + GB = MG + \frac{4R}{3\pi}$$

$$\text{or: } MG = \frac{L^2}{3\pi R} - \frac{4R}{3\pi} > 0 \text{ (stability) if } L/R > 2 \text{ Ans.}$$

P2.137 A tank of water 4 m deep receives a constant upward acceleration a_z . Determine (a) the gage pressure at the tank bottom if $a_z = 5 \text{ m}^2/\text{s}$; and (b) the value of a_z which causes the gage pressure at the tank bottom to be 1 atm.

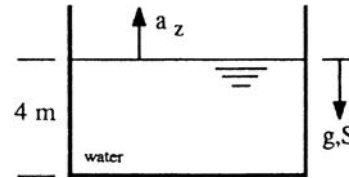

Solution: Equation (2.53) states that $\nabla p = \rho(\mathbf{g} - \mathbf{a}) = \rho(-k\mathbf{g} - k\mathbf{a}_z)$ for this case. Then, for part (a),

$$\Delta p = \rho(g + a_z)\Delta S = (998 \text{ kg/m}^3)(9.81 + 5 \text{ m}^2/\text{s})(4 \text{ m}) = \mathbf{59100 \text{ Pa (gage) Ans. (a)}}$$

For part (b), we know $\Delta p = 1 \text{ atm}$ but we don't know the acceleration:

$$\Delta p = \rho(g + a_z)\Delta S = (998)(9.81 + a_z)(4.0) = 101350 \text{ Pa if } \mathbf{a_z = 15.6 \frac{m}{s^2} Ans. (b)}$$

P2.138 A 12 fluid ounce glass, 3 inches in diameter, sits on the edge of a merry-go-round 8 ft in diameter, rotating at 12 r/min. How full can the glass be before it spills?

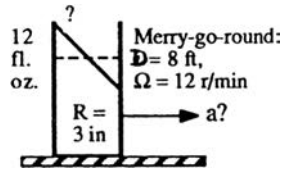

Solution: First, how high is the container? Well, 1 fluid oz. = 1.805 in³, hence 12 fl. oz. = 21.66 in³ = $\pi(1.5 \text{ in})^2 h$, or $h \approx 3.06 \text{ in}$ —It is a fat, nearly square little glass. Second, determine the acceleration toward the center of the merry-go-round, noting that the angular velocity is $\Omega = (12 \text{ rev/min})(1 \text{ min}/60 \text{ s})(2\pi \text{ rad/rev}) = 1.26 \text{ rad/s}$. Then, for $r = 4 \text{ ft}$,

$$a_x = \Omega^2 r = (1.26 \text{ rad/s})^2 (4 \text{ ft}) = 6.32 \text{ ft/s}^2$$

Then, for steady rotation, the water surface in the glass will slope at the angle

$$\tan \theta = \frac{a_x}{g + a_z} = \frac{6.32}{32.2 + 0} = 0.196, \quad \text{or: } \Delta h_{\text{left to center}} = (0.196)(1.5 \text{ in}) = 0.294 \text{ in}$$

Thus the glass should be filled to no more than $3.06 - 0.294 \approx 2.77 \text{ inches}$

This amount of liquid is $v = \pi (1.5 \text{ in})^2 (2.77 \text{ in}) = 19.6 \text{ in}^3 \approx \mathbf{10.8 \text{ fluid oz.}}$ Ans.

P2.139 The tank of liquid in the figure P2.139 accelerates to the right with the fluid in rigid-body motion. (a) Compute a_x in m/s^2 . (b) Why doesn't the solution to part (a) depend upon fluid density? (c) Compute gage pressure at point A if the fluid is glycerin at 20°C.

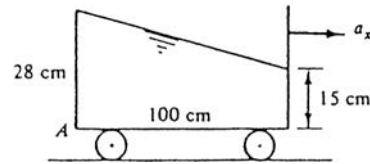

Fig. P2.139

Solution: (a) The slope of the liquid gives us the acceleration:

$$\tan \theta = \frac{a_x}{g} = \frac{28 - 15}{100} = 0.13, \quad \text{or: } \theta = 7.4^\circ$$

$$\text{thus } a_x = 0.13g = 0.13(9.81) = \mathbf{1.28 \text{ m/s}^2} \quad \text{Ans. (a)}$$

(b) Clearly, the solution to (a) is purely geometric and does not involve fluid density. *Ans.* (b)
 (c) From Table A-3 for glycerin, $\rho = 1260 \text{ kg/m}^3$. There are many ways to compute p_A . For example, we can go straight down on the left side, using only gravity:

$$p_A = \rho g \Delta z = (1260 \text{ kg/m}^3)(9.81 \text{ m/s}^2)(0.28 \text{ m}) = \mathbf{3460 \text{ Pa (gage)}} \quad \text{Ans. (c)}$$

Or we can start on the right side, go down 15 cm with g and across 100 cm with a_x :

$$\begin{aligned} p_A &= \rho g \Delta z + \rho a_x \Delta x = (1260)(9.81)(0.15) + (1260)(1.28)(1.00) \\ &= 1854 + 1607 = \mathbf{3460 \text{ Pa}} \quad \text{Ans. (c)} \end{aligned}$$

P2.140 The U-tube in Fig. P2.140 is moving to the right with variable velocity. The water level in the left tube is 6 cm, and the level in the right tube is 16 cm. Determine the acceleration and its direction.

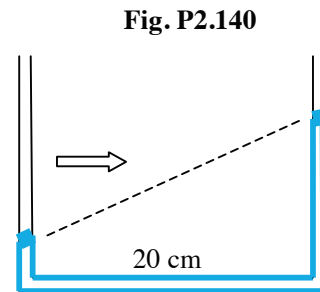

Fig. P2.140

Solution: Since the motion is horizontal, $a_z = 0$. The “free surface” slope is *up* to the right, which from Fig. 2.21 is negative:

$$\tan \theta = \frac{6 \text{ cm} - 16 \text{ cm}}{20 \text{ cm}} = -0.5 = \frac{a_x}{g}; \quad a_x = -0.5g = -0.5(9.81) = \mathbf{-4.9 \text{ m}^2 / \text{s}} \quad \text{Ans.}$$

The tube is *decelerating* as it moves to the right.

P2.141 The same tank from Prob. P2.139 is now accelerating while rolling *up* a 30° inclined plane, as shown. Assuming rigid-body motion, compute (a) the acceleration \mathbf{a} , (b) whether the acceleration is up or down, and (c) the pressure at point A if the fluid is mercury at 20°C .

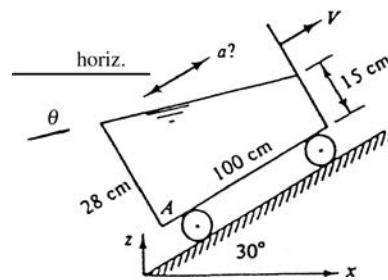

Fig. P2.141

Solution: The free surface is tilted at the angle $\theta = -30^\circ + 7.41^\circ = -22.59^\circ$. This angle must satisfy Eq. (2.55):

$$\tan \theta = \tan(-22.59^\circ) = -0.416 = a_x / (g + a_z)$$

But the 30° incline constrains the acceleration such that $a_x = 0.866a$, $a_z = 0.5a$. Thus

$$\tan \theta = -0.416 = \frac{0.866a}{9.81 + 0.5a}, \quad \text{solve for } \mathbf{a \approx -3.80 \frac{m}{s^2} \text{ (down) } \quad \text{Ans. (a, b)}$$

The cartesian components are $a_x = -3.29 \text{ m/s}^2$ and $a_z = -1.90 \text{ m/s}^2$.

(c) The distance ΔS normal from the surface down to point A is $(28 \cos \theta)$ cm. Thus

$$p_A = \rho [a_x^2 + (g + a_z)^2]^{1/2} = (13550) [(-3.29)^2 + (9.81 - 1.90)^2]^{1/2} (0.28 \cos 7.41^\circ) \\ \approx \mathbf{32200 \text{ Pa (gage) } \quad \text{Ans. (c)}$$

P2.142 The tank of water in Fig. P2.142 is 12 cm wide into the paper. If the tank is accelerated to the right in rigid-body motion at 6 m/s^2 , compute (a) the water depth at AB, and (b) the water force on panel AB.

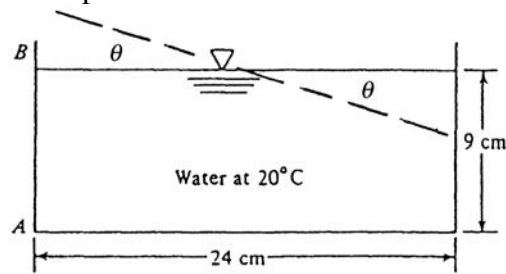

Fig. P2.142

Solution: From Eq. (2.55),

$$\tan \theta = a_x / g = \frac{6.0}{9.81} = 0.612, \quad \text{or } \theta \approx 31.45^\circ$$

Then surface point B on the left rises an additional $\Delta z = 12 \tan \theta \approx 7.34 \text{ cm}$,

$$\text{or: water depth AB} = 9 + 7.34 \approx \mathbf{16.3 \text{ cm} \quad \text{Ans. (a)}}$$

The water pressure on AB varies linearly due to gravity only, thus the water force is

$$F_{AB} = p_{CG} A_{AB} = (9790) \left(\frac{0.163}{2} \text{ m} \right) (0.163 \text{ m})(0.12 \text{ m}) \approx \mathbf{15.7 \text{ N}} \quad \text{Ans. (b)}$$

P2.143 The tank of water in Fig. P2.143 is full and open to the atmosphere ($p_{\text{atm}} = 15 \text{ psi} = 2160 \text{ psf}$) at point A, as shown. For what acceleration a_x , in ft/s^2 , will the pressure at point B in the figure be (a) atmospheric; and (b) zero absolute (neglecting cavitation)?

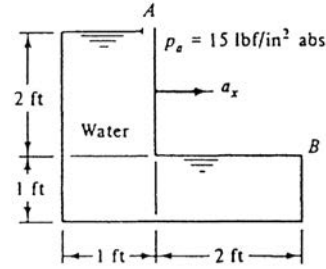

Fig. P2.143

Solution: (a) For $p_A = p_B$, the imaginary ‘free surface isobar’ should join points A and B:

$$\tan \theta_{AB} = \tan 45^\circ = 1.0 = a_x/g, \quad \text{hence } a_x = g = \mathbf{32.2 \text{ ft/s}^2} \quad \text{Ans. (a)}$$

(b) For $p_B = 0$, the free-surface isobar must tilt even more than 45° , so that

$$p_B = 0 = p_A + \rho g \Delta z - \rho a_x \Delta x = 2160 + 1.94(32.2)(2) - 1.94 a_x (2),$$

$$\text{solve } a_x = \mathbf{589 \text{ ft/s}^2} \quad \text{Ans. (b)}$$

This is a very high acceleration (18 g 's) and a very steep angle, $\theta = \tan^{-1}(589/32.2) = 87^\circ$.

P2.144 Consider a hollow cube of side length 22 cm, full of water at 20°C , and open to $p_{\text{atm}} = 1 \text{ atm}$ at top corner A. The top surface is horizontal. Determine the rigid-body accelerations for which the water at opposite top corner B will *cavitate*, for (a) horizontal, and (b) vertical motion.

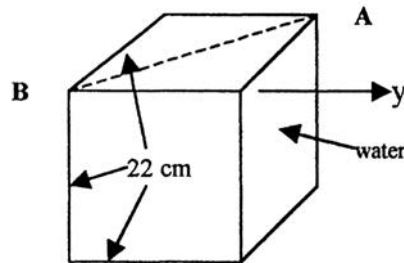

Solution: From Table A-5 the vapor pressure of the water is 2337 Pa. (a) Thus cavitation occurs first when accelerating horizontally along the diagonal AB:

$$p_A - p_B = 101325 - 2337 = \rho a_{x,AB} \Delta L_{AB} = (998) a_{x,AB} (0.22\sqrt{2}),$$

$$\text{solve } a_{x,AB} = \mathbf{319 \text{ m/s}^2} \quad \text{Ans. (a)}$$

If we moved along the y axis shown in the figure, we would need $a_y = 319\sqrt{2} = 451 \text{ m/s}^2$. (b) For *vertical* acceleration, **nothing would happen**, both points A and B would continue to be atmospheric, although the pressure at deeper points would change. *Ans.*

P2.145 A fish tank 16-in by 27-in by 14-inch deep is carried in a car which may experience accelerations as high as 6 m/s^2 . Assuming rigid-body motion, estimate the maximum water depth to avoid spilling. Which is the best way to align the tank?

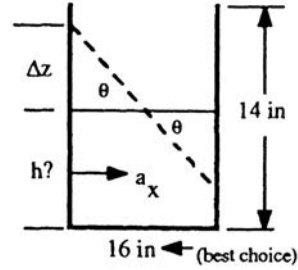

Solution: The best way is to align the 16-inch width with the car's direction of motion, to minimize the vertical surface change Δz . From Eq. (2.55) the free surface angle will be

$$\tan \theta_{\max} = a_x/g = \frac{6.0}{9.81} = 0.612, \quad \text{thus } \Delta z = \frac{16''}{2} \tan \theta = 4.9 \text{ inches } (\theta = 31.5^\circ)$$

Thus the tank should contain no more than $14 - 4.9 \approx \mathbf{9.1 \text{ inches of water}}$. *Ans.*

P2.146 The tank in Fig. P2.146 is filled with water and has a vent hole at point A. It is 1 m wide into the paper. Inside is a 10-cm balloon filled with helium at 130 kPa. If the tank accelerates to the right at 5 m/s^2 , at what angle will the balloon lean? Will it lean to the left or to the right?

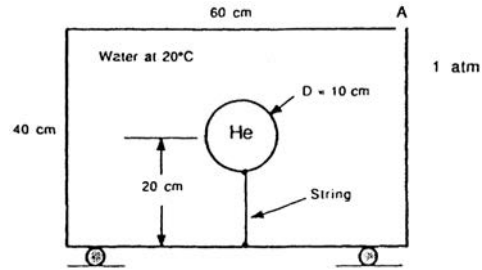
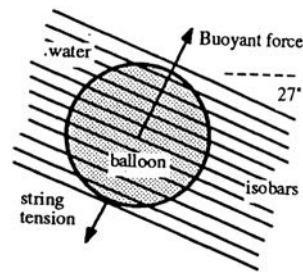

Fig. P2.146

Solution: The acceleration sets up pressure isobars which slant down and to the right, in both the water and in the helium. This means there will be a buoyancy force on the balloon up and to the right, as shown at right. It must be balanced by a string tension down and to the left. If we neglect balloon material weight, the balloon leans up and to the right at angle



$$\theta = \tan^{-1} \left(\frac{a_x}{g} \right) = \tan^{-1} \left(\frac{5.0}{9.81} \right) \approx 27^\circ \quad \text{Ans.}$$

measured from the vertical. This acceleration-buoyancy effect may seem counter-intuitive.

P2.147 The tank of water in Fig. P2.147 accelerates uniformly by rolling without friction down the 30° inclined plane. What is the angle θ of the free surface? Can you explain this interesting result?

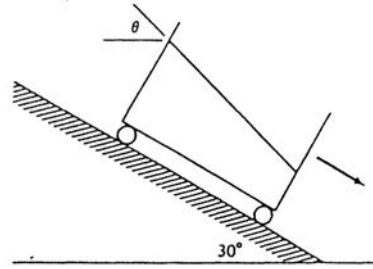

Fig. P2.147

Solution: If frictionless, $\Sigma F = W \sin \theta = ma$ along the incline and thus $a = g \sin 30^\circ = 0.5g$.

$$\text{Thus } \tan \theta = \frac{a_x}{g + a_z} = \frac{0.5g \cos 30^\circ}{g - 0.5g \sin 30^\circ}; \text{ solve for } \theta = 30^\circ! \text{ Ans.}$$

The free surface aligns itself exactly parallel with the 30° incline.

P2.148 A child is holding a string onto which is attached a helium-filled balloon. (a) The child is standing still and suddenly accelerates forward. In a frame of reference moving with the child, which way will the balloon tilt, forward or backward? Explain. (b) The child is now sitting in a car that is stopped at a red light. The helium-filled balloon is not in contact with any part of the car (seats, ceiling, etc.) but is held in place by the string, which is held by the child. All the windows in the car are closed. When the traffic light turns green, the car accelerates forward. In a frame of reference moving with the car and child, which way will the balloon tilt, forward or backward? Explain. (c) Purchase or borrow a helium-filled balloon. Conduct a scientific experiment to see if your predictions in parts (a) and (b) are correct. If not, explain.

Solution: (a) Only the child and balloon accelerate, not the surrounding air. This is *not* rigid-body fluid motion. **The balloon will tilt backward** due to air drag. *Ans.(a)*

(b) Inside the car, the trapped air will accelerate with the car and the child, etc. This is rigid-body motion. **The balloon will tilt forward**, as in Prob. P2.146. *Ans.(b)*

(c) A student in the writer's class actually tried this experimentally. Our predictions were correct.

P2.149 The waterwheel in Fig. P2.149 lifts water with 1-ft-diameter half-cylinder blades. The wheel rotates at 10 r/min. What is the water surface angle θ at pt. A?

Solution: Convert $\Omega = 10 \text{ r/min} = 1.05 \text{ rad/s}$. Use an average radius $R = 6.5 \text{ ft}$. Then

$$a_x = \Omega^2 R = (1.05)^2 (6.5) \approx 7.13 \text{ ft/s}^2 \quad \text{toward the center}$$

$$\text{Thus } \tan \theta = a_x/g = 7.13/32.2, \quad \text{or: } \theta = \mathbf{12.5^\circ} \quad \text{Ans.}$$

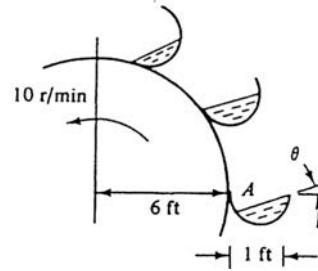

Fig. P2.149

P2.150 A cheap accelerometer can be made from the U-tube at right. If $L = 18 \text{ cm}$ and $D = 5 \text{ mm}$, what will h be if $a_x = 6 \text{ m/s}^2$?

Solution: We assume that the diameter is so small, $D \ll L$, that the free surface is a "point." Then Eq. (2.55) applies, and

$$\tan \theta = a_x/g = \frac{6.0}{9.81} = 0.612, \quad \text{or } \theta = 31.5^\circ$$

$$\text{Then } h = (L/2) \tan \theta = (9 \text{ cm})(0.612) = \mathbf{5.5 \text{ cm}} \quad \text{Ans.}$$

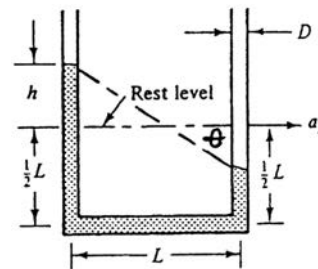

Fig. P2.150

Since $h = (9 \text{ cm})a_x/g$, the scale readings are indeed linear in a_x , but I don't recommend it as an actual accelerometer, there are too many inaccuracies and disadvantages.

P2.151 The U-tube in Fig. P2.151 is open at A and closed at D. What uniform acceleration a_x will cause the pressure at point C to be atmospheric? The fluid is water.

Solution: If pressures at A and C are the same, the "free surface" must join these points:

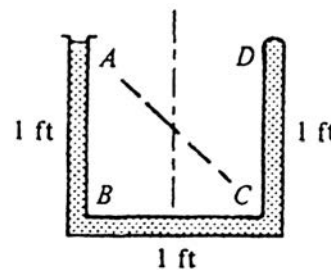
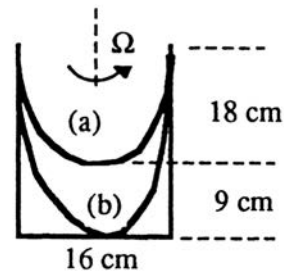

Fig. P2.151

$$\theta = 45^\circ, \quad a_x = g \tan \theta = g = \mathbf{32.2 \text{ ft/s}^2} \quad \text{Ans.}$$

P2.152 A 16-cm-diameter open cylinder 27 cm high is full of water. Find the central rigid-body rotation rate for which (a) one-third of the water will spill out; and (b) the bottom center of the can will be exposed.



Solution: (a) One-third will spill out if the resulting paraboloid surface is 18 cm deep:

$$h = 0.18 \text{ m} = \frac{\Omega^2 R^2}{2g} = \frac{\Omega^2 (0.08 \text{ m})^2}{2(9.81)}, \text{ solve for } \Omega^2 = 552,$$

$$\Omega = 23.5 \text{ rad/s} = \mathbf{224 \text{ r/min}} \quad \text{Ans. (a)}$$

(b) The bottom is barely exposed if the paraboloid surface is 27 cm deep:

$$h = 0.27 \text{ m} = \frac{\Omega^2 (0.08 \text{ m})^2}{2(9.81)}, \text{ solve for } \Omega = 28.8 \text{ rad/s} = \mathbf{275 \text{ r/min}} \quad \text{Ans. (b)}$$

P2.153 A cylindrical container, 14 inches in diameter, is used to make a mold for forming salad bowls. The bowls are to be 8 inches deep. The cylinder is half-filled with molten plastic, $\mu = 1.6 \text{ kg}/(\text{m}\cdot\text{s})$, rotated steadily about the central axis, then cooled while rotating. What is the appropriate rotation rate, in r/min?

Solution: The molten plastic viscosity is a red herring, ignore. The appropriate final rotating surface shape is a paraboloid of radius 7 inches and depth 8 inches. Thus, from Fig. 2.23,

$$h = 8 \text{ in} = \frac{8}{12} \text{ ft} = \frac{\Omega^2 R^2}{2g} = \frac{\Omega^2 (7/12 \text{ ft})^2}{2(32.2 \text{ ft/s}^2)}$$

$$\text{Solve for } \Omega = 11.2 \frac{\text{rad}}{\text{s}} \times \frac{60}{2\pi} = \mathbf{107 \frac{\text{r}}{\text{min}}} \quad \text{Ans.}$$

P2.154 A very tall 10-cm-diameter vase contains 1178 cm^3 of water. When spun steadily to achieve rigid-body rotation, a 4-cm-diameter dry spot appears at the bottom of the vase. What is the rotation rate, r/min , for this condition?

Solution: It is interesting that the answer has nothing to do with the water *density*. The value of 1178 cubic centimeters was chosen to make the rest depth a nice number:

$$v = 1178 \text{ cm}^3 = \pi(5 \text{ cm})^2 H, \text{ solve } H = 15.0 \text{ cm}$$

One way would be to integrate and find the volume of the shaded liquid in Fig. P2.154 in terms of vase radius R and dry-spot radius r_o . That would yield the following formula:

$$dv = \pi(R^2 - r_o^2) dz, \text{ but } z = \Omega^2 r^2 / 2g, \text{ hence } dz = (\Omega^2 r / g) dr$$

$$\text{Thus } v = \int_{r_o}^R \pi(R^2 - r_o^2)(\Omega^2 r / g) dr = \frac{\pi\Omega^2}{g} \int_{r_o}^R (R^2 r - r^3) dr = \frac{\pi\Omega^2}{g} \left(\frac{R^2 r^2}{2} - \frac{r^4}{4} \right) \Big|_{r_o}^R$$

$$\text{Finally: } v = \frac{\pi\Omega^2}{g} \left(\frac{R^4}{4} - \frac{R^2 r_o^2}{2} + \frac{r_o^4}{4} \right) = 0.001178 \text{ m}^3$$

$$\text{Solve for } R = 0.05 \text{ m}, r_o = 0.02 \text{ m} : \Omega^2 = 3336, \Omega = 57.8 \frac{\text{rad}}{\text{s}} = \mathbf{552 \frac{\text{r}}{\text{min}}} \text{ Ans.}$$

The formulas in the text, concerning the paraboloids of “air”, would, in the writer’s opinion, be difficult to apply because of the free surface extending below the bottom of the vase.

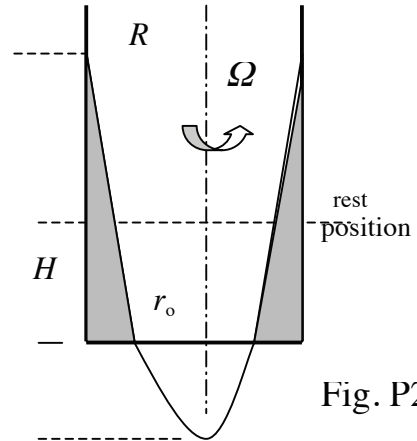

Fig. P2.154

P2.155 For what uniform rotation rate in r/min about axis C will the U-tube fluid in Fig. P2.155 take the position shown? The fluid is mercury at 20°C.

Solution: Let h_0 be the height of the free surface at the centerline. Then, from Eq. (2.64),

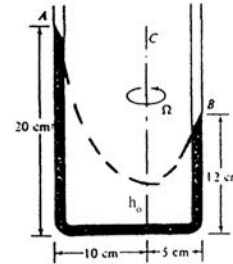

Fig. P2.155

$$z_B = h_0 + \frac{\Omega^2 R_B^2}{2g}; \quad z_A = h_0 + \frac{\Omega^2 R_A^2}{2g}; \quad R_B = 0.05 \text{ m} \quad \text{and} \quad R_A = 0.1 \text{ m}$$

$$\text{Subtract: } z_A - z_B = 0.08 \text{ m} = \frac{\Omega^2}{2(9.81)} [(0.1)^2 - (0.05)^2],$$

$$\text{solve } \Omega = 14.5 \frac{\text{rad}}{\text{s}} = \mathbf{138 \frac{r}{\text{min}}} \quad \text{Ans.}$$

The fact that the fluid is mercury does not enter into this “kinematic” calculation.

P2.156 Suppose the U-tube of Prob. P2.151 is rotated about axis DC. If the fluid is water at 122°F and atmospheric pressure is 2116 psfa, at what rotation rate will the fluid begin to vaporize? At what point in the tube will this happen?

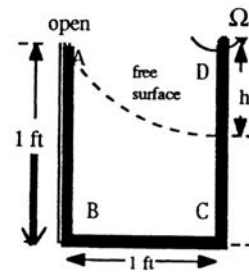

Solution: At 122°F = 50°C, from Tables A-1 and A-5, for water, $\rho = 988 \text{ kg/m}^3$ (or 1.917 slug/ft³) and $p_v = 12.34 \text{ kPa}$ (or 258 psf). When spinning around DC, the free surface comes down from point A to a position *below* point D, as shown. Therefore the fluid pressure is lowest at point D (*Ans.*). With h as shown in the figure,

$$p_D = p_{\text{vap}} = 258 = p_{\text{atm}} - \rho gh = 2116 - 1.917(32.2)h, \quad h = \Omega^2 R^2 / (2g)$$

Solve for $h \approx 30.1$ ft (!) Thus the drawing is wildly distorted and the dashed line falls **far below** point C! (The solution is correct, however.)

$$\text{Solve for } \Omega^2 = 2(32.2)(30.1)/(1 \text{ ft})^2 \quad \text{or: } \Omega = 44 \text{ rad/s} = \mathbf{420 \text{ rev/min.}} \quad \text{Ans.}$$

P2.157 The 45° V-tube in Fig. P2.157 contains water and is open at A and closed at C. (a) For what rigid-body rotation rate will the pressure be equal at points B and C? (b) For the condition of part (a), at what point in leg BC will the pressure be a minimum?

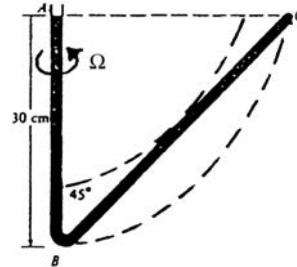

Fig. P2.157

Solution: (a) If pressures are equal at B and C, they must lie on a constant-pressure paraboloid surface as sketched in the figure. Taking $z_B = 0$, we may use Eq. (2.64):

$$z_C = 0.3 \text{ m} = \frac{\Omega^2 R^2}{2g} = \frac{\Omega^2 (0.3)^2}{2(9.81)}, \quad \text{solve for } \Omega = 8.09 \frac{\text{rad}}{\text{s}} = \mathbf{77 \frac{\text{rev}}{\text{min}}} \quad \text{Ans. (a)}$$

(b) The minimum pressure in leg BC occurs where the highest paraboloid pressure contour is tangent to leg BC, as sketched in the figure. This family of paraboloids has the formula

$$z = z_0 + \frac{\Omega^2 r^2}{2g} = r \tan 45^\circ, \quad \text{or: } z_0 + 3.333r^2 - r = 0 \quad \text{for a pressure contour}$$

$$\text{The minimum occurs when } dz/dr = 0, \quad \text{or } r \approx \mathbf{0.15 \text{ m}} \quad \text{Ans. (b)}$$

The minimum pressure occurs *halfway between points B and C*.

P2.158* It is desired to make a 3-m-diameter parabolic telescope mirror by rotating molten glass in rigid-body motion until the desired shape is achieved and then cooling the glass to a solid. The focus of the mirror is to be 4 m from the mirror, measured along the centerline. What is the proper mirror rotation rate, in rev/min?

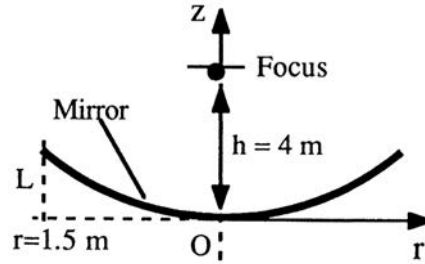

Solution: We have to review our math book, or a handbook, to recall that the *focus* F of a parabola is the point for which all points on the parabola are equidistant from both the focus and a so-called “directrix” line (which is one focal length below the mirror).

For the focal length h and the z - r axes shown in the figure, the equation of the parabola is given by $r^2 = 4hz$, with $h = 4$ m for our example.

Meanwhile the equation of the free-surface of the liquid is given by $z = r^2\Omega^2/(2g)$.

Set these two equal to find the proper rotation rate:

$$z = \frac{r^2\Omega^2}{2g} = \frac{r^2}{4h}, \quad \text{or:} \quad \Omega^2 = \frac{g}{2h} = \frac{9.81}{2(4)} = 1.226$$

$$\text{Thus } \Omega = 1.107 \frac{\text{rad}}{\text{s}} \left(\frac{60}{2\pi} \right) = \mathbf{10.6 \text{ rev/min}} \quad \text{Ans.}$$

The focal point F is far above the mirror itself. If we put in $r = 1.5$ m and calculate the mirror depth “ L ” shown in the figure, we get $L \approx 14$ centimeters.

P2.159 The three-legged manometer in Fig. P2.159 is filled with water to a depth of 20 cm. All tubes are long and have equal small diameters. If the system spins at angular velocity Ω about the central tube, (a) derive a formula to find the change of height in the tubes; (b) find the height in cm in each tube if $\Omega = 120$ rev/min. [*HINT:* The central tube must supply water to *both* the outer legs.]

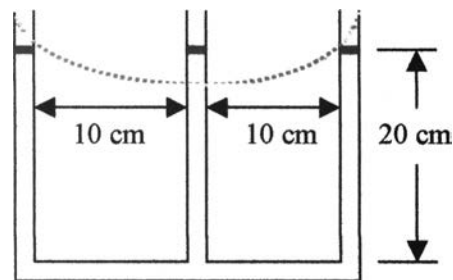

Fig. P2.159

Solution: (a) The free-surface during rotation is visualized as the dashed line in Fig. P2.159. The outer right and left legs experience an increase which is one-half that of the central leg, or $\Delta h_O = \Delta h_C/2$. The total displacement between outer and center

menisci is, from Eq. (2.64) and Fig. 2.23, equal to $\Omega^2 R^2/(2g)$. The center meniscus falls two-thirds of this amount and feeds the outer tubes, which each rise one-third of this amount above the rest position:

$$\Delta h_{outer} = \frac{1}{3} \Delta h_{total} = \frac{\Omega^2 R^2}{6g} \quad \Delta h_{center} = -\frac{2}{3} \Delta h_{total} = -\frac{\Omega^2 R^2}{3g} \quad \text{Ans. (a)}$$

For the particular case $R = 10$ cm and $\Omega = 120$ r/min = $(120)(2\pi/60) = 12.57$ rad/s, we obtain

$$\frac{\Omega^2 R^2}{2g} = \frac{(12.57 \text{ rad/s})^2 (0.1 \text{ m})^2}{2(9.81 \text{ m/s}^2)} = 0.0805 \text{ m};$$

$$\Delta h_O \approx \mathbf{0.027 \text{ m (up)}} \quad \Delta h_C \approx \mathbf{-0.054 \text{ m (down)}} \quad \text{Ans. (b)}$$

P2.160 Figure P2.160 shows a low-pressure gage invented in 1874 by Herbert McLeod. (a) Can you deduce, from the figure, how it works? (b) If not, read about it and explain it to the class.



Fig. P2.160

Solution: The McLeod gage takes a sample of low-pressure gas and compresses it, with a liquid, usually mercury for its low vapor pressure, into a closed capillary tube with a reservoir of known volume. A manometer measures the compressed gas pressure and the sample pressure is found by Boyle's Law, $pU = \text{constant}$. It can measure pressures as low as 10^{-5} torr.

P2.161 Figure P2.161 shows a sketch of a commercial pressure gage.

(a) Can you deduce, from the figure, how it works?

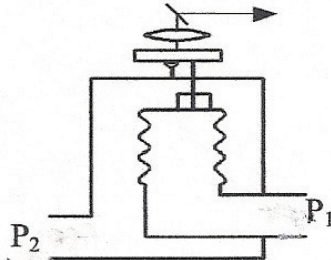

Fig. P2.161

Solution: This is a bellows-type *diaphragm gage*, with optical output. The pressure difference moves the bellows, which tilts the lens and thus changes the output.

FUNDAMENTALS OF ENGINEERING EXAM PROBLEMS: Answers

FE-P2.1 A gage attached to a pressurized nitrogen tank reads a gage pressure of 28 inches of mercury. If atmospheric pressure is 14.4 psia, what is the absolute pressure in the tank?

- (a) 95 kPa (b) 99 kPa (c) 101 kPa (d) **194 kPa** (e) 203 kPa

FE-P2.2 On a sea-level standard day, a pressure gage, moored below the surface of the ocean (SG = 1.025), reads an absolute pressure of 1.4 MPa. How deep is the instrument?

- (a) 4 m (b) **129 m** (c) 133 m (d) 140 m (e) 2080 m

FE-P2.3 In Fig. FE-P2.3, if the oil in region B has SG = 0.8 and the absolute pressure

at point A is 1 atmosphere, what is the absolute pressure at point B?

- (a) 5.6 kPa (b) 10.9 kPa (c) **106.9 kPa**
(d) 112.2 kPa (e) 157.0 kPa

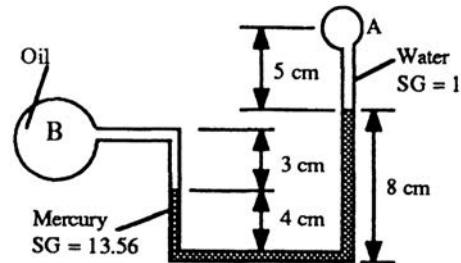

Fig. FE-P2.3

FE-P2.4 In Fig. FE-P2.3, if the oil in region B has SG = 0.8 and the absolute pressure at point B is 14 psia, what is the absolute pressure at point A?

- (a) 11 kPa (b) 41 kPa (c) 86 kPa (d) **91 kPa** (e) 101 kPa

FE-P2.5 A tank of water (SG = 1.0) has a gate in its vertical wall 5 m high and 3 m wide. The top edge of the gate is 2 m below the surface. What is the hydrostatic force on the gate?

- (a) 147 kN (b) 367 kN (c) 490 kN (d) **661 kN** (e) 1028 kN

FE-P2.6 In Prob. FE-P2.5 above, how far below the surface is the center of pressure of the hydrostatic force?

- (a) 4.50 m (b) 5.46 m (c) 6.35 m (d) 5.33 m (e) **4.96 m**

FE-P2.7 A solid 1-m-diameter sphere floats at the interface between water (SG = 1.0) and mercury (SG = 13.56) such that 40% is in the water. What is the specific gravity of the sphere?

- (a) 6.02 (b) 7.28 (c) 7.78 (d) **8.54** (e) 12.56

FE-P2.8 A 5-m-diameter balloon contains helium at 125 kPa absolute and 15°C, moored in sea-level standard air. If the gas constant of helium is 2077 m²/(s²·K) and balloon material weight is neglected, what is the net lifting force of the balloon?

- (a) 67 N (b) 134 N (c) 522 N (d) **653 N** (e) 787 N

FE-P2.9 A square wooden (SG = 0.6) rod, 5 cm by 5 cm by 10 m long, floats vertically in water at 20°C when 6 kg of steel (SG = 7.84) are attached to the lower end. How high above the water surface does the wooden end of the rod protrude?

(a) 0.6 m (b) 1.6 m (c) **1.9 m** (d) 2.4 m (e) 4.0 m

FE-P2.10 A floating body will always be stable when its

- (a) CG is above the center of buoyancy (b) center of buoyancy is below the waterline
(c) center of buoyancy is above its metacenter (d) metacenter is above the center of buoyancy
(e) **metacenter is above the CG**

COMPREHENSIVE PROBLEMS

C2.1 Some manometers are constructed as in the figure at right, with one large reservoir and one small tube open to the atmosphere. We can then neglect movement of the reservoir level. If the reservoir is not large, its level will move, as in the figure. Tube height h is measured from the zero-pressure level, as shown.

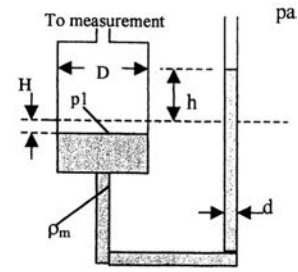

(a) Let the reservoir pressure be high, as in the Figure, so its level goes down. Write an exact Expression for $p_{1\text{gage}}$ as a function of h , d , D , and gravity g . (b) Write an approximate expression for $p_{1\text{gage}}$, neglecting the movement of the reservoir. (c) Suppose $h = 26$ cm, $p_a = 101$ kPa, and $\rho_m = 820$ kg/m³. Estimate the ratio (D/d) required to keep the error in (b) less than 1.0% and also $< 0.1\%$. Neglect surface tension.

Solution: Let H be the downward movement of the reservoir. If we neglect air density, the pressure difference is $p_1 - p_a = \rho_m g(h + H)$. But volumes of liquid must balance:

$$\frac{\pi}{4} D^2 H = \frac{\pi}{4} d^2 h, \quad \text{or: } H = (d/D)^2 h$$

Then the pressure difference (exact except for air density) becomes

$$p_1 - p_a = p_{1\text{gage}} = \rho_m g h (1 + d^2/D^2) \quad \text{Ans. (a)}$$

If we ignore the displacement H , then $p_{1\text{gage}} \approx \rho_m g h$ Ans. (b)

(c) For the given numerical values, $h = 26$ cm and $\rho_m = 820$ kg/m³ are irrelevant, all that matters is the ratio d/D . That is,

$$\text{Error } E = \frac{\Delta p_{\text{exact}} - \Delta p_{\text{approx}}}{\Delta p_{\text{exact}}} = \frac{(d/D)^2}{1 + (d/D)^2}, \quad \text{or: } D/d = \sqrt{(1 - E)/E}$$

For $E = 1\%$ or 0.01, $D/d = [(1 - 0.01)/0.01]^{1/2} \geq \mathbf{9.95}$ Ans. (c-1%)

For $E = 0.1\%$ or 0.001, $D/d = [(1 - 0.001)/0.001]^{1/2} \geq \mathbf{31.6}$ Ans. (c-0.1%)

C2.2 A prankster has added oil, of specific gravity SG_o , to the left leg of the manometer at right. Nevertheless, the U-tube is still to be used to measure the pressure in the air tank. (a) Find an expression for h as a function of H and other parameters in the problem. (b) Find the special case of your result when $p_{\text{tank}} = p_a$. (c) Suppose $H = 5$ cm, $p_a = 101.2$ kPa, $SG_o = 0.85$, and p_{tank} is 1.82 kPa higher than p_a . Calculate h in cm, ignoring surface tension and air density effects.

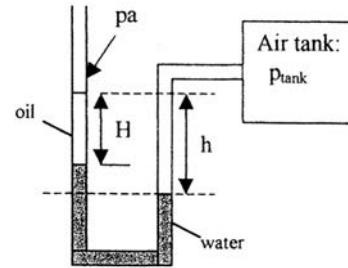

Solution: Equate pressures at level i in the tube (the right hand water level):

$$p_i = p_a + \rho g H + \rho_w g (h - H) = p_{\text{tank}},$$

$$\rho = SG_o \rho_w \quad (\text{ignore the column of air in the right leg})$$

$$\text{Solve for: } h = \frac{p_{\text{tk}} - p_a}{\rho_w g} + H(1 - SG_o) \quad \text{Ans. (a)}$$

If $p_{\text{tank}} = p_a$, then

$$h = H(1 - SG_o) \quad \text{Ans. (b)}$$

(c) For the particular numerical values given above, the answer to (a) becomes

$$h = \frac{1820 \text{ Pa}}{998(9.81)} + 0.05(1 - 0.85) = 0.186 + 0.0075 = 0.193 \text{ m} = \mathbf{19.3 \text{ cm}} \quad \text{Ans. (c)}$$

Note that this result is not affected by the actual value of atmospheric pressure.

C2.3 Professor F. Dynamics, riding the merry-go-round with his son, has brought along his U-tube manometer. (You never know when a manometer might come in handy.) As shown in Fig. C2.3, the merry-go-round spins at constant angular velocity and the manometer legs are 7 cm apart. The manometer center is 5.8 m from the axis of rotation. Determine the height difference h in two ways: (a) approximately, by assuming rigid body translation with \mathbf{a} equal to the average manometer acceleration; and (b) exactly, using rigid-body rotation theory. How good is the approximation?

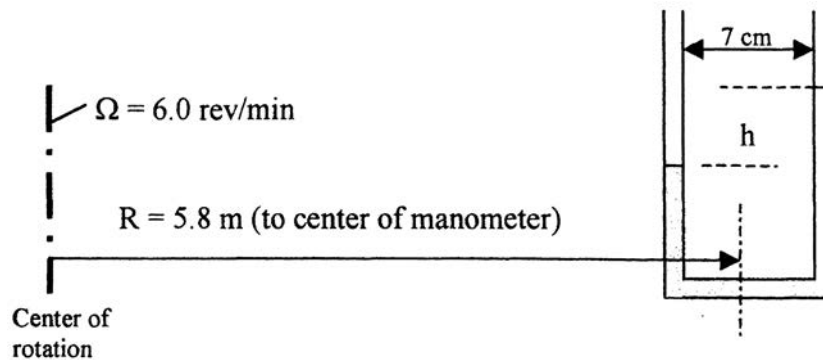

Solution: (a) Approximate: The average acceleration of the manometer is $R_{\text{avg}}\Omega^2 = 5.8[6(2\pi/60)]^2 = 2.29 \text{ rad/s}$ toward the center of rotation, as shown. Then

$$\tan(\theta) = a/g = 2.29/9.81 = h/(7 \text{ cm}) = 0.233$$

$$\text{Solve for } h = \mathbf{1.63 \text{ cm}} \quad \text{Ans. (a)}$$

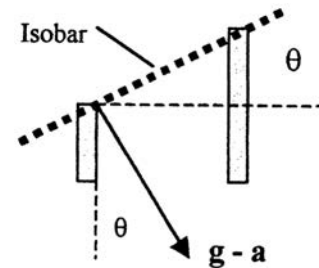

(b) Exact: The isobar in the figure at right would be on the parabola $z = C + r^2\Omega^2/(2g)$, where C is a constant. Apply this to the left leg (z_1) and right leg (z_2). As above, the rotation rate is $\Omega = 6.0*(2\pi/60) = 0.6283 \text{ rad/s}$. Then

$$\begin{aligned} h = z_2 - z_1 &= \frac{\Omega^2}{2g}(r_2^2 - r_1^2) = \frac{(0.6283)^2}{2(9.81)}[(5.8 + 0.035)^2 - (5.8 - 0.035)^2] \\ &= \mathbf{0.0163 \text{ m}} \quad \text{Ans. (b)} \end{aligned}$$

This is nearly identical to the approximate answer (a), because $R \gg \Delta r$.

C2.4 A student sneaks a glass of cola onto a roller coaster ride. The glass is cylindrical, twice as tall as it is wide, and filled to the brim. He wants to know what percent of the cola he should drink before the ride begins, so that none of it spills during the big drop, in which

the roller coaster achieves 0.55-g acceleration at a 45° angle below the horizontal. Make the calculation for him, neglecting sloshing and assuming that the glass is vertical at all times.

Solution: We have both horizontal and vertical acceleration. Thus the angle of tilt α is

$$\tan \alpha = \frac{a_x}{g + a_z} = \frac{0.55g \cos 45^\circ}{g - 0.55g \sin 45^\circ} = 0.6364$$

Thus $\alpha = 32.47^\circ$. The tilted surface strikes the centerline at $R \tan \alpha = 0.6364R$ below the top. So the student should drink the cola until its rest position is $0.6364R$ below the top. The percentage drop in liquid level (and therefore liquid volume) is

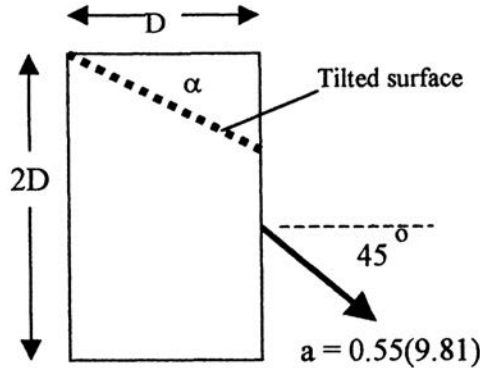

$$\% \text{ removed} = \frac{0.6364R}{4R} = 0.159 \text{ or: } \mathbf{15.9\% \text{ Ans.}}$$

C2.5 Dry adiabatic lapse rate is defined as $\text{DALR} = -dT/dz$ when T and p vary isentropically. Assuming $T = Cp^a$, where $a = (\gamma - 1)/\gamma$, $\gamma = c_p/c_v$, (a) show that $\text{DALR} = g(\gamma - 1)/(\gamma R)$, $R = \text{gas constant}$; and (b) calculate DALR for air in units of $^\circ\text{C}/\text{km}$.

Solution: Write $T(p)$ in the form $T/T_o = (p/p_o)^a$ and differentiate:

$$\frac{dT}{dz} = T_o a \left(\frac{p}{p_o} \right)^{a-1} \frac{1}{p_o} \frac{dp}{dz}, \text{ But for the hydrostatic condition: } \frac{dp}{dz} = -\rho g$$

Substitute $\rho = p/RT$ for an ideal gas, combine above, and rewrite:

$$\frac{dT}{dz} = -\frac{T_o}{p_o} a \left(\frac{p}{p_o} \right)^{a-1} \frac{p}{RT} g = -\frac{ag}{R} \left(\frac{T_o}{T} \right) \left(\frac{p}{p_o} \right)^a. \text{ But: } \frac{T_o}{T} \left(\frac{p}{p_o} \right)^a = 1 \text{ (isentropic)}$$

Therefore, finally,

$$-\frac{dT}{dz} = DALR = \frac{ag}{R} = \frac{(\gamma - 1)\mathbf{g}}{\gamma\mathbf{R}} \quad \text{Ans. (a)}$$

(b) Regardless of the actual air temperature and pressure, the DALR for **air** equals

$$DALR = -\left.\frac{dT}{dz}\right|_s = \frac{(1.4-1)(9.81 \text{ m/s}^2)}{1.4(287 \text{ m}^2/\text{s}^2/^\circ\text{C})} = 0.00977 \frac{^\circ\text{C}}{\text{m}} = \mathbf{9.77 \frac{^\circ\text{C}}{\text{km}}} \quad \text{Ans. (b)}$$

C2.6 Use the approximate pressure-density relation for a “soft” liquid,

$$dp = a^2 d\rho, \quad \text{or} \quad p = p_o + a^2(\rho - \rho_o)$$

where a is the speed of sound and (ρ_o, p_o) are the conditions at the liquid surface $z = 0$. Use this approximation to derive a formula for the density distribution $\rho(z)$ and pressure distribution $p(z)$ in a column of soft liquid. Then find the force F on a vertical wall of width b , extending from $z = 0$ down to $z = -h$, and compare with the incompressible result $F = \rho_o gh^2 b/2$.

Solution: Introduce this $p(\rho)$ relation into the hydrostatic relation (2.18) and integrate:

$$dp = a^2 d\rho = -\gamma dz = -\rho g dz, \quad \text{or:} \quad \int_{\rho_o}^{\rho} \frac{d\rho}{\rho} = -\int_0^z \frac{g dz}{a^2}, \quad \text{or:} \quad \rho = \rho_o e^{-gz/a^2} \quad \text{Ans.}$$

assuming constant a^2 . Substitute into the $p(\rho)$ relation to obtain the pressure distribution:

$$p \approx p_o + a^2 \rho_o [e^{-gz/a^2} - 1] \quad (1)$$

Since $p(z)$ increases with z at a greater than linear rate, the center of pressure will always be a little lower than predicted by linear theory (Eq. 2.44). Integrate Eq. (1) above, neglecting p_o , into the pressure force on a vertical plate extending from $z = 0$ to $z = -h$:

$$F = -\int_0^{-h} p b dz = \int_{-h}^0 a^2 \rho_o (e^{-gz/a^2} - 1) b dz = \mathbf{ba^2 \rho_o \left[\frac{a^2}{g} (e^{gh/a^2} - 1) - h \right]} \quad \text{Ans.}$$

In the limit of small depth change relative to the “softness” of the liquid, $h \ll a^2/g$, this reduces to the linear formula $F = \rho_o gh^2 b/2$ by expanding the exponential into the first three terms of its series. For “hard” liquids, the difference in the two formulas is negligible. For example, for water ($a \approx 1490$ m/s) with $h = 10$ m and $b = 1$ m, the linear formula predicts $F = 489500$ N while the exponential formula predicts $F = 489507$ N.

C2.7 Venice, Italy is slowly sinking, so now, especially in winter, plazas and walkways are flooded.

The proposed solution is the floating levee of Fig. C2.7. When filled with air, it rises to block off the sea. The levee is 30 m high and 5 m wide. Assume a uniform density of 300 kg/m^3 when floating. For the 1-meter

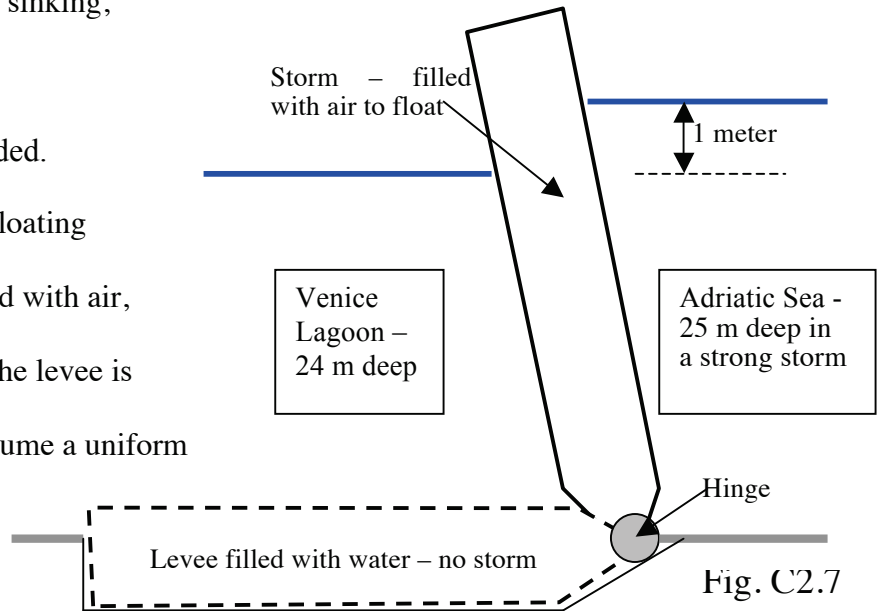

Sea-Lagoon difference shown, estimate the angle at which the levee floats.

Solution: The writer thinks this problem is rather laborious. Assume $\rho_{\text{seawater}} = 1025 \text{ kg/m}^3$.

There are 4 forces: the hydrostatic force F_{AS} on the Adriatic side, the hydrostatic force F_{VL} on the lagoon side, the weight W of the levee, and the buoyancy B of the submerged part of the levee. On the Adriatic

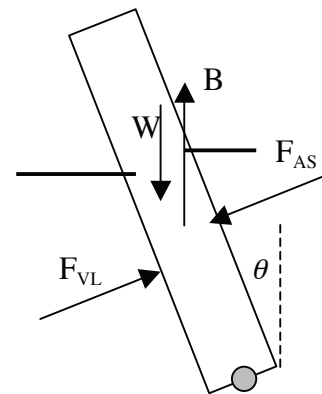

side, $25/\cos\theta$ meters are submerged. On the lagoon side,

$24/\cos\theta$ meters are submerged. For buoyancy, average the two depths, $(25+24)/2 = 24.5$ m.

For weight, the whole length of 30 m is used. Compute the four forces per unit width into the paper (since this width b will cancel out of all moments):

$$F_{AS} = \rho g h_{AS} L_{submerged} = (1025)(9.81)(25/2)(25/\cos\theta) = 3.142E6/\cos\theta$$

$$F_{VL} = \rho g h_{VL} L_{submerged} = (1025)(9.81)(24/2)(24/\cos\theta) = 2.896E6/\cos\theta$$

$$W = \rho_{levee} g L(\text{levee width}) = (300)(9.81)(30)(5) = 441500 \text{ N/m}$$

$$B = \rho g L_{sub-average}(\text{levee width}) = (1025)(9.81)(24.5)(5) = 1.232E6 \text{ N/m}$$

The hydrostatic forces have CP two-thirds of the way down the levee surfaces. The weight CG is in the center of the levee (15 m above the hinge). The buoyancy center is halfway down from the surface, or about $(24.5)/2$ m. The moments about the hinge are

$$\Sigma M_{hinge} = F_{AS}\left(\frac{25/\cos\theta}{3}m\right) + W(15m)\sin\theta - F_{VL}\left(\frac{24/\cos\theta}{3}m\right) - B\left(\frac{24.5}{2}m\right)\sin\theta = 0$$

where the forces are listed above and are not retyped here. Everything is known except the listing angle θ (measured from the vertical). Some iteration is required, say, on Excel, With a good initial guess (about $\theta = 15\text{-}30^\circ$), Excel converges to

$$\theta \approx 26.3^\circ \text{ Ans.}$$

C2.8 In the U.S. Standard Atmosphere, the lapse rate B may vary from day to day. It is not a fundamental quantity like, say, Planck's constant. Suppose that, on a certain day in Rhode Island, with $T_0 = 288$ K, the following pressures are measured by weather balloons:

Altitude z , km	0	2	5	8
-------------------	---	---	---	---

Pressure p , kPa	100	78	53	34
--------------------	-----	----	----	----

Estimate the best-fit value of B for this data. Explain any difficulties.

[Hint: Excel is recommended.]

Solution: If you plot this distribution $p(z)$, it is very smooth, as shown below. But the data are extraordinarily sensitive to the value of B .

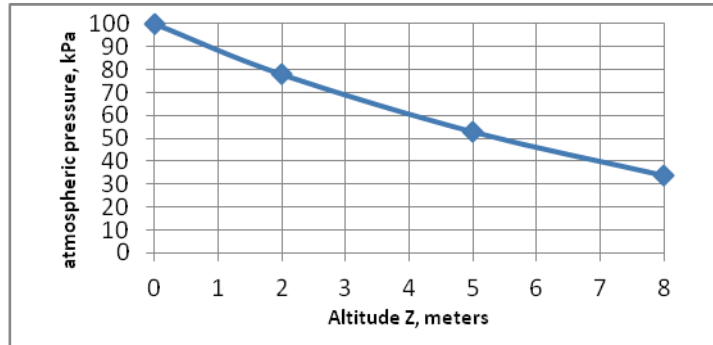

Equation (2.20) is very difficult to solve for B , thus Excel iteration is recommended.

Altitude z , km	2	5	8
Lapse rate B , °C/m	0.01282	0.00742	0.00831

The average value is $B \approx 0.0095 \pm 20\%$, but the value with the least standard deviation from the pressure is $B = 0.0077$. Such data does not yield an accurate value of B . For example, if the measured pressures are off 1%, the values of B can vary as much as 40%. The accepted value $B = 0.00650$ °C/m is better found by a linear curve-fit to measured *temperatures*.

C2.9 The deep submersible vehicle ALVIN in the chapter-opener photo has a hollow titanium sphere of inside diameter 78.08 inches and thickness 1.93 in. If the vehicle is submerged to a depth of 3,850 m in the ocean, estimate (a) the water pressure outside the

sphere; (b) the maximum elastic stress in the sphere, in lbf/in²; and (c) the factor of safety of the titanium alloy (6% aluminum, 4% vanadium).

Solution: This problem requires you to know (or read about) some solid mechanics!

(a) The hydrostatic (gage) pressure outside the submerged sphere would be

$$p_{water} \approx \rho_{water} g h = (1025 \text{ kg/m}^3)(9.81 \text{ m/s}^2)(3850 \text{ m}) \approx 3.87\text{E}7 \text{ Pa} = 5600 \text{ Psi}$$

If we corrected for water compressibility, the result would increase by the small amount of 0.9%, giving as final estimate of $p_{water} = 3.90\text{E}7 \text{ Pa} \approx \mathbf{5665 \text{ lbf/in}^2}$. *Ans.(a)*

(b) From any textbook on elasticity or strength of materials, the maximum elastic stress in a hollow sphere under external pressure is *compression* and occurs at the inside surface. If a is the inside radius (39.04 in) and b the outside radius, $39.04+1.93\text{in} = 40.97$ in, the formula for maximum stress is

$$\sigma_{\max} = p_{water} \frac{3b^3}{2(b^3 - a^3)} = (3.90\text{E}7) \frac{3(40.97 \text{ in})^3}{2(40.97^3 - 39.04^3)} = 4.34\text{E}8 \text{ Pa} \approx \mathbf{63,000 \text{ psi}} \quad \text{Ans.(b)}$$

Various references found by the writer give the ultimate tensile strength of titanium alloys as 130,000 to 160,000 psi. Thus the factor of safety, based on *tensile* strength, is approximately

2.1 to 2.5.

Ans.(c)

NOTE: For titanium, the ultimate compressive strength should be similar to the tensile strength. FURTHER NOTE: It is better to base the factor of safety on *yield* strength.
