

SOLUTIONS MANUAL

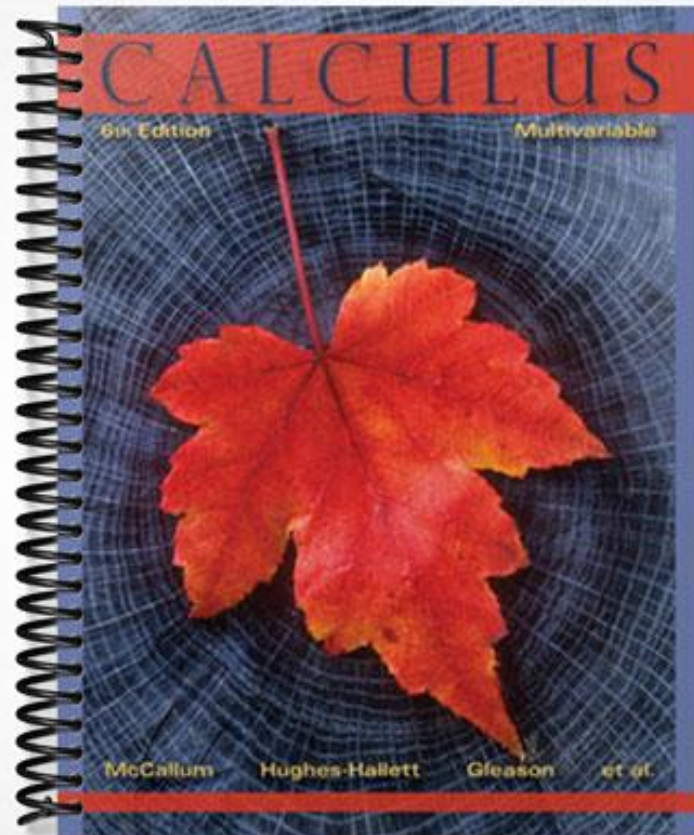

CHAPTER TWELVE

Solutions for Section 12.1

Exercises

- The point P is $\sqrt{1^2 + 2^2 + 1^2} = \sqrt{6} = 2.45$ units from the origin, and Q is $\sqrt{2^2 + 0^2 + 0^2} = 2$ units from the origin. Since $2 < \sqrt{6}$, the point Q is closer.
- The distance formula: $d = \sqrt{(x_2 - x_1)^2 + (y_2 - y_1)^2 + (z_2 - z_1)^2}$ gives us the distance between any pair of points (x_1, y_1, z_1) and (x_2, y_2, z_2) . Thus, we find

$$\text{Distance from } P_1 \text{ to } P_2 = 2\sqrt{2}$$

$$\text{Distance from } P_2 \text{ to } P_3 = \sqrt{6}$$

$$\text{Distance from } P_1 \text{ to } P_3 = \sqrt{10}$$

So P_2 and P_3 are closest to each other.

- The distance of a point $P = (x, y, z)$ from the yz -plane is $|x|$, from the xz -plane is $|y|$, and from the xy -plane is $|z|$. So, B is closest to the yz -plane, since it has the smallest x -coordinate in absolute value. B lies on the xz -plane, since its y -coordinate is 0. B is farthest from the xy -plane, since it has the largest z -coordinate in absolute value.
- Your final position is $(1, -1, 1)$. This places you in front of the yz -plane, to the left of the xz -plane, and above the xy -plane.
- An example is the line $y = z$ in the yz -plane. See Figure 12.1.

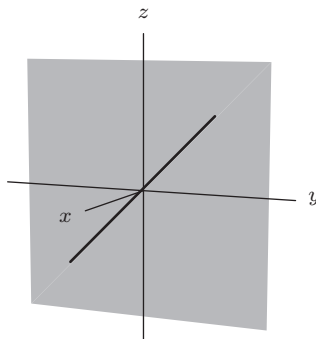

Figure 12.1

- The midpoint is found by averaging coordinates:

$$\text{Midpoint} = \left(\frac{-1 + 5}{2}, \frac{3 + 6}{2}, \frac{9 - 3}{2} \right) = (2, 4.5, 3).$$

- The graph is a horizontal plane at height 4 above the xy -plane. See Figure 12.2.

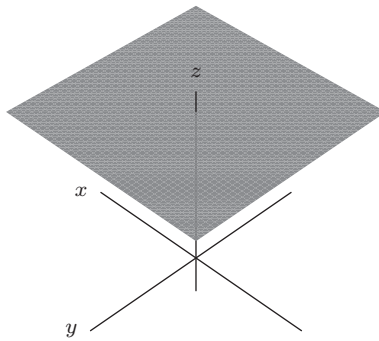

Figure 12.2

8. The graph is a plane parallel to the yz -plane, and passing through the point $(-3, 0, 0)$. See Figure 12.3.

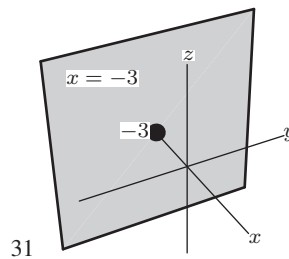

Figure 12.3

9. The graph is a plane parallel to the xz -plane, and passing through the point $(0, 1, 0)$. See Figure 12.4.

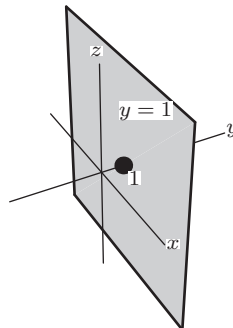

Figure 12.4

10. The graph is all points with $y = 4$ and $z = 2$, i.e., a line parallel to the x -axis and passing through the points $(0, 4, 2)$; $(2, 4, 2)$; $(4, 4, 2)$ etc. See Figure 12.5.

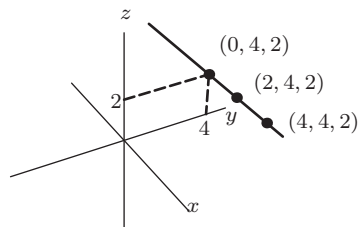

Figure 12.5

- 11. The radius is $7 - (-1) = 8$, so the highest point is at $(2, 3, 15)$.
- 12. The equation is $x^2 + y^2 + z^2 = 25$
- 13. The sphere has equation $(x - 1)^2 + y^2 + z^2 = 4$.
- 14. The plane has equation $y = 3$.
- 15. (a) $80-90^\circ\text{F}$
 (b) $60-72^\circ\text{F}$
 (c) $60-100^\circ\text{F}$
- 16.

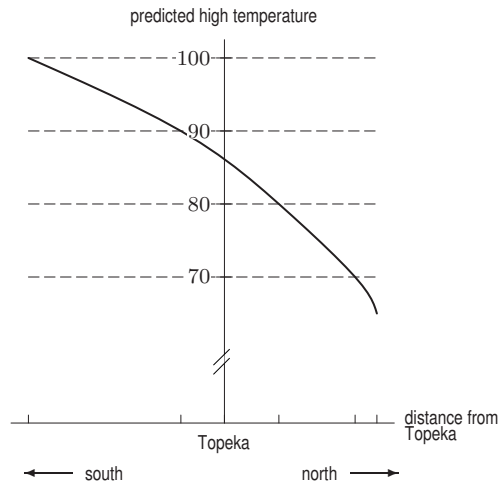

Figure 12.6

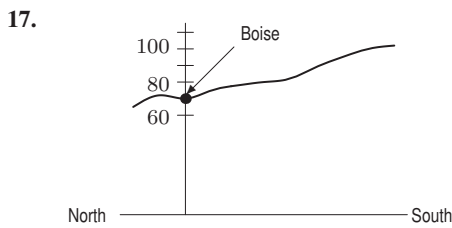

Figure 12.7

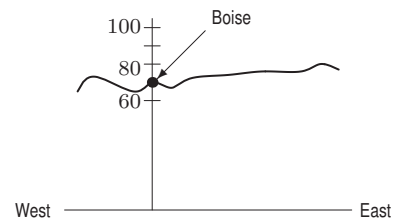

Figure 12.8

- 18. Beef consumption by households making \$20,000/year is given by Row 1 of Table 12.1 on page 667 of the text.

Table 12.1

p	3.00	3.50	4.00	4.50
$f(20, p)$	2.65	2.59	2.51	2.43

For households making \$20,000/year, beef consumption decreases as price goes up.
 Beef consumption by households making \$100,000/year is given by Row 5 of Table 12.1.

Table 12.2

p	3.00	3.50	4.00	4.50
$f(100, p)$	5.79	5.77	5.60	5.53

For households making \$100,000/year, beef consumption also decreases as price goes up.
 Beef consumption by households when the price of beef is \$3.00/lb is given by Column 1 of Table 12.1.

Table 12.3

I	20	40	60	80	100
$f(I, 3.00)$	2.65	4.14	5.11	5.35	5.79

When the price of beef is \$3.00/lb, beef consumption increases as income increases.

Beef consumption by households when the price of beef is \$4.00/lb is given by Column 3 of Table 12.1.

Table 12.4

I	20	40	60	80	100
$f(I, 4.00)$	2.51	3.94	4.97	5.19	5.60

When the price of beef is \$4.00/lb, beef consumption increases as income increases.

19. Table 12.5 gives the amount M spent on beef per household per week. Thus, the amount the household spent on beef in a year is $52M$. Since the household's annual income is I thousand dollars, the proportion of income spent on beef is

$$P = \frac{52M}{1000I} = 0.052 \frac{M}{I}.$$

Thus, we need to take each entry in Table 12.5, divide it by the income at the left, and multiply by 0.052. Table 12.6 shows the results.

Table 12.5 Money spent on beef
(\$/household/week)

Income (\$1,000)	Price of Beef (\$)			
	3.00	3.50	4.00	4.50
20	7.95	9.07	10.04	10.94
40	12.42	14.18	15.76	17.46
60	15.33	17.50	19.88	21.78
80	16.05	18.52	20.76	22.82
100	17.37	20.20	22.40	24.89

Table 12.6 Proportion of annual income spent on beef

Income (\$1,000)	Price of Beef (\$)			
	3.00	3.50	4.00	4.50
20	0.021	0.024	0.026	0.028
40	0.016	0.018	0.020	0.023
60	0.013	0.015	0.017	0.019
80	0.010	0.012	0.013	0.015
100	0.009	0.011	0.012	0.013

20. If the price of beef is held constant, beef consumption for households with various incomes can be read from a fixed column in Table 12.1 on page 667 of the text. For example, the column corresponding to $p = 3.00$ gives the function $h(I) = f(I, 3.00)$; it tells you how much beef a household with income I will buy at \$3.00/lb. Looking at the column from the top down, you can see that it is an increasing function of I . This is true in every column. This says that at any fixed price for beef, consumption goes up as household income goes up—which makes sense. Thus, f is an increasing function of I for each value of p .

Problems

21. (a) According to Table 12.2 of the problem, it feels like -19°F .
 (b) A wind of 20 mph, according to Table 12.2.
 (c) About 17.5 mph. Since at a temperature of 25°F , when the wind increases from 15 mph to 20 mph, the temperature adjusted for wind chill decreases from 13°F to 11°F , we can say that a 5 mph increase in wind speed causes a 2°F decrease in the temperature adjusted for wind chill. Thus, each 2.5 mph increase in wind speed brings *about* a 1°F drop in the temperature adjusted for wind chill. If the wind speed at 25°F increases from 15 mph to 17.5 mph, then the temperature you feel will be $13 - 1 = 12^\circ\text{F}$.
 (d) Table 12.2 shows that with wind speed 20 mph the temperature will feel like 0°F when the air temperature is somewhere between 15°F and 20°F . When the air temperature drops 5°F from 20°F to 15°F , the temperature adjusted for wind-chill drops 6°F from 4°F to -2°F . We can say that for every 1°F decrease in air temperature there is *about* a $6/5 = 1.2^\circ\text{F}$ drop in the temperature you feel. To drop the temperature you feel from 4°F to 0°F will take an air temperature drop of about $4/1.2 = 3.3^\circ\text{F}$ from 20°F . With a wind of 20 mph, approximately $20 - 3.3 = 16.7^\circ\text{F}$ would feel like 0°F .

22.

Table 12.7 Temperature adjusted for wind chill at $20^{\circ}F$

Wind speed (mph)	5	10	15	20	25
Adjusted temperature ($^{\circ}F$)	13	9	6	4	3

Table 12.8 Temperature adjusted for wind chill at $0^{\circ}F$

Wind speed (mph)	5	10	15	20	25
Adjusted temperature ($^{\circ}F$)	-11	-16	-19	-22	-24

23.

Table 12.9 Temperature adjusted for wind chill at 5 mph

Temperature ($^{\circ}F$)	35	30	25	20	15	10	5	0
Adjusted temperature ($^{\circ}F$)	31	25	19	13	7	1	-5	-11

Table 12.10 Temperature adjusted for wind chill at 20 mph

Temperature ($^{\circ}F$)	35	30	25	20	15	10	5	0
Adjusted temperature ($^{\circ}F$)	24	17	11	4	-2	-9	-15	-22

24. (a) The total cost in dollars of renting a car is 40 times the number of days plus 0.15 times the number of miles driven, so

$$C = f(d, m) = 40d + 0.15m.$$

- (b) We have

$$f(5, 300) = 40(5) + 0.15(300) = \$245.$$

Renting a car for 5 days and driving it 300 miles costs \$245.

25. The gravitational force on a 100 kg object which is 7,000,000 meters from the center of the earth (or about 600 km above the earth's surface) is about 820 newtons.
26. (a) The acceleration due to gravity decreases as h increases, because the gravitational force gets weaker the farther away you are from the planet. (In fact, g is inversely proportional to the square of the distance from the center of the planet.)
 (b) The acceleration due to gravity increases as m increases. The more massive the planet, the larger the gravitational force. (In fact, g is proportional to m .)
27. By drawing the top four corners, we find that the length of the edge of the cube is 5. See Figure 12.9. We also notice that the edges of the cube are parallel to the coordinate axis. So the x -coordinate of the center equals

$$-1 + \frac{5}{2} = 1.5.$$

The y -coordinate of the center equals

$$-2 + \frac{5}{2} = 0.5.$$

The z -coordinate of the center equals

$$2 - \frac{5}{2} = -0.5.$$

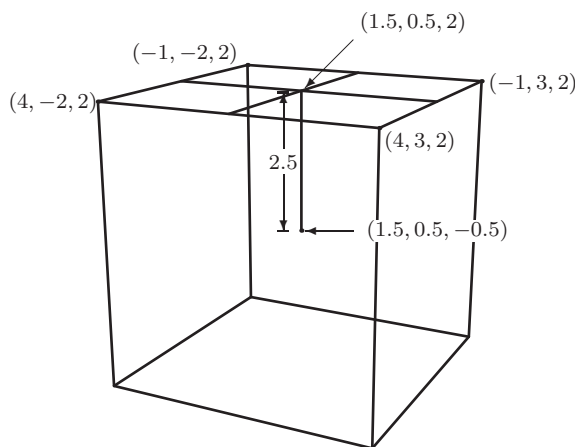

Figure 12.9

28. The equation for the points whose distance from the x -axis is 2 is given by $\sqrt{y^2 + z^2} = 2$, i.e. $y^2 + z^2 = 4$. It specifies a cylinder of radius 2 along the x -axis. See Figure 12.10.

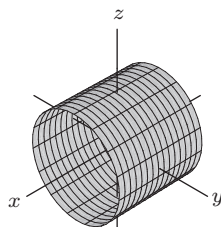

Figure 12.10

29. The distance of any point with coordinates (x, y, z) from the x -axis is $\sqrt{y^2 + z^2}$. The distance of the point from the xy -plane is $|z|$. Since the condition states that these distances are equal, the equation for the condition is

$$\sqrt{y^2 + z^2} = |z| \quad \text{i.e.} \quad y^2 + z^2 = z^2.$$

This is the equation of a cone whose tip is at the origin and which opens along the x -axis with a slope of 1 as shown in Figure 12.11.

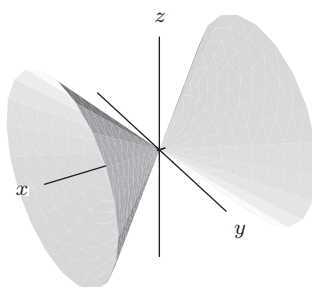

Figure 12.11

30. The coordinates of points on the y -axis are $(0, y, 0)$. The distance from any such point $(0, y, 0)$ to the point (a, b, c) is $d = \sqrt{a^2 + (b - y)^2 + c^2}$. Therefore, the closest point will have $y = b$ in order to minimize d . The resulting distance is then: $d = \sqrt{a^2 + c^2}$.

31. (a) The sphere has center at $(2, 3, 3)$ and radius 4. The planes parallel to the xy -plane just touching the sphere are 4 above and 4 below the center. Thus, the planes $z = 7$ and $z = -1$ are both parallel to the xy -plane and touch the sphere at the points $(2, 3, 7)$ and $(2, 3, -1)$.
- (b) The planes $x = 6$ and $x = -2$ just touch the sphere at $(6, 3, 3)$ and at $(-2, 3, 3)$ respectively and are parallel to the yz -plane.
- (c) The planes $y = 7$ and $y = -1$ just touch the sphere at $(2, 7, 3)$ and at $(2, -1, 3)$ respectively and are parallel to the xz -plane.
32. The edges of the cube have length 4. Thus, the center of the sphere is the center of the cube which is the point $(4, 7, 1)$ and the radius is $r = 2$. Thus an equation of this sphere is

$$(x - 4)^2 + (y - 7)^2 + (z - 1)^2 = 4.$$

33. (a) The vertex at the opposite end of a diagonal across the base is $(12, 7, 2)$. The other two points are $(5, 7, 2)$ and $(12, 1, 2)$.
- (b) The vertex at the opposite end of a diagonal across the top is $(5, 1, 4)$. The other two points are $(5, 7, 4)$ and $(12, 1, 4)$.
34. Using the distance formula, we find that

$$\text{Distance from } P_1 \text{ to } P = \sqrt{206}$$

$$\text{Distance from } P_2 \text{ to } P = \sqrt{152}$$

$$\text{Distance from } P_3 \text{ to } P = \sqrt{170}$$

$$\text{Distance from } P_4 \text{ to } P = \sqrt{113}$$

So $P_4 = (-4, 2, 7)$ is closest to $P = (6, 0, 4)$.

35. (a) To find the intersection of the sphere with the yz -plane, substitute $x = 0$ into the equation of the sphere:

$$(-1)^2 + (y + 3)^2 + (z - 2)^2 = 4,$$

therefore

$$(y + 3)^2 + (z - 2)^2 = 3$$

This equation represents a circle of radius $\sqrt{3}$.

On the xz -plane $y = 0$:

$$(x - 1)^2 + 3^2 + (z - 2)^2 = 4,$$

therefore

$$(x - 1)^2 + (z - 2)^2 = -5$$

The negative sign on the right side of this equation shows that the sphere does not intersect the xz -plane, since the left side of the equation is always non-negative.

On the xy -plane, $z = 0$:

$$(x - 1)^2 + (y + 3)^2 + (-2)^2 = 4,$$

therefore

$$(x - 1)^2 + (y + 3)^2 = 0.$$

This equation has the unique solution $x = 1, y = -3$, so the xy -plane intersects the sphere in the single point $(1, -3, 0)$.

- (b) Since the sphere does not intersect the xz -plane, it cannot intersect the x or z axes. On the y -axis, we have $x = z = 0$. Substituting this into the equation for the sphere we get

$$(-1)^2 + (y + 3)^2 + (-2)^2 = 4,$$

therefore

$$(y + 3)^2 = -1.$$

This equation has no solutions because the right hand side is negative, and the left-hand side is always non-negative. Thus the sphere does not intersect any of the coordinate axes.

36. The length corresponds to the y -axis, therefore the y -coordinates of the corners must be $1 \pm \frac{13}{2} = -5.5, 7.5$. See

Figure 12.12. The height corresponds to the z -axis, therefore the z -coordinates of the corners must be $-2 \pm \frac{5}{2} = 0.5, -4.5$. The width corresponds to the x -axis, therefore the x -coordinates of the corners must be $1 \pm 3 = 4, -2$. The coordinates of those eight corners are therefore

$$(4, 7.5, 0.5), (-2, 7.5, 0.5), (-2, -5.5, 0.5), (4, -5.5, 0.5), \\ (4, 7.5, -4.5), (-2, 7.5, -4.5), (-2, -5.5, -4.5), (4, -5.5, -4.5).$$

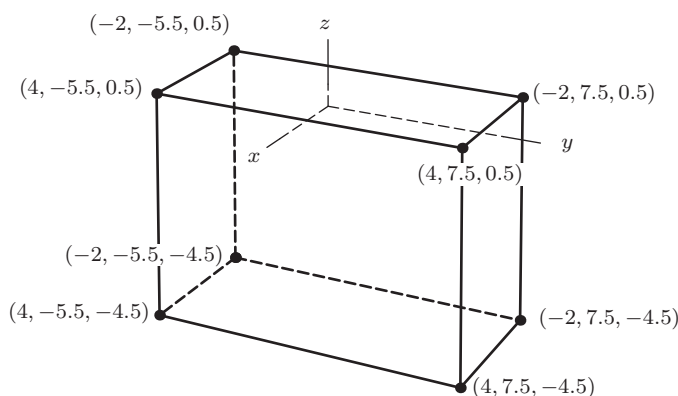

Figure 12.12

37. The length of the side of the triangle is 2, so its height is $\sqrt{3}$. The coordinates of the highest point are $(8, 0, \sqrt{3})$.
38. (a) We find the midpoint by averaging

$$\text{Midpoint} = \left(\frac{1+5}{2}, \frac{5+13}{2}, \frac{7+19}{2} \right) = (3, 9, 13).$$

- (b) We use a weighted average, with the coordinates of point A weighted three times more heavily than point B :

$$\text{Point} = \left(\frac{3 \cdot 1 + 5}{4}, \frac{3 \cdot 5 + 13}{4}, \frac{3 \cdot 7 + 19}{4} \right) = (2, 7, 10).$$

- (c) We find the point in a similar way to part (b), but weighting B more heavily

$$\text{Point} = \left(\frac{1 + 3 \cdot 5}{4}, \frac{5 + 3 \cdot 13}{4}, \frac{7 + 3 \cdot 19}{4} \right) = (4, 11, 16).$$

Strengthen Your Understanding

39. The graph of the equation $y = 1$ is a plane perpendicular to the y -axis, not a line. The x -axis is parallel to the plane.
40. The xy -plane has equation $z = 0$.
The equation $xy = 0$ means either $x = 0$ (the equation of the yz -plane) or $y = 0$ (the equation of the xz -plane). Points on the xy -plane all have $z = 0$; this is its equation.
41. The closest point on the x -axis to $(2, 3, 4)$ is $(2, 0, 0)$. The distance from $(2, 3, 4)$ to this point is
- $$d = \sqrt{(2-2)^2 + (3-0)^2 + (4-0)^2} = \sqrt{25} = 5.$$
42. One possible function that is increasing in x and decreasing in y is given by the formula $f(x, y) = x - y$. For a fixed value of x , the value of $x - y$ decreases as y increases, and for a fixed value of y , the value of $x - y$ increases as x increases. There are many other possible answers.
43. If we pick a point with $z = -5$, its distance from the plane $z = -5$ is zero. The distance of a point from the xz -plane is the magnitude of the y -coordinate. So the point $(-2, -1, -5)$ is a distance of 1 from the xz -plane and a distance of zero from the plane $z = -5$. There are many other possible points.

44. True. Since each choice of x and y determines a unique value for $f(x, y)$, choosing $x = 10$ yields a unique value of $f(10, y)$ for any choice of y .
45. True. Since each choice of $h > 0$ and $s > 0$ determines a unique value for the volume V , we can say V is a function of h and s . In fact, this function has a formula: $V(h, s) = h \cdot s^2$.
46. False. If, for example, $d = 2$ meters and $H = 57^\circ\text{C}$, there could be many times t at which the water temperature is 57°C at 2 meters depth.
47. False. A function may have different inputs that yield equal outputs.
48. True. Since each of $f(x)$ and $g(y)$ has at most one output for each input, so does their product.
49. True. All points in the $z = 2$ plane have z -coordinate 2, hence are below any point of the form $(a, b, 3)$.
50. False. The plane $z = 2$ is parallel to the xy -plane.
51. True. Both are distance $\sqrt{2}$ from the origin.
52. False. The point $(2, -1, 3)$ does not satisfy the equation. It is at the center of the sphere, and does not lie on the graph.
53. True. The origin is the closest point in the yz -plane to the point $(3, 0, 0)$, and its distance to $(3, 0, 0)$ is 3.
54. False. There is an entire circle (of radius 4) of points in the yz -plane that are distance 5 from $(3, 0, 0)$.
55. False. The value of b can be ± 4 .
56. True. Otherwise f would have more than one value for a given pair (x, y) , which cannot happen if f is a function.
57. False. For example, the y -axis intersects the graph of $f(x, y) = 1 - x^2 - y^2$ twice, at $y = \pm 1$.

Solutions for Section 12.2

Exercises

1. (a) The value of z decreases as x increases. See Figure 12.13.
 (b) The value of z increases as y increases. See Figure 12.14.

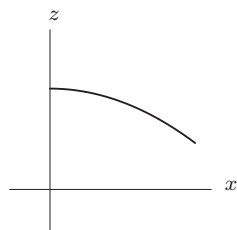

Figure 12.13

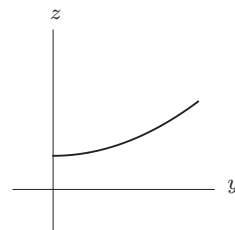

Figure 12.14

2. (a) is (IV), since $z = 2 + x^2 + y^2$ is a paraboloid opening upward with a positive z -intercept.
 (b) is (II), since $z = 2 - x^2 - y^2$ is a paraboloid opening downward.
 (c) is (I), since $z = 2(x^2 + y^2)$ is a paraboloid opening upward and going through the origin.
 (d) is (V), since $z = 2 + 2x - y$ is a slanted plane.
 (e) is (III), since $z = 2$ is a horizontal plane.
3. (a) The value of z only depends on the distance from the point (x, y) to the origin. Therefore the graph has a circular symmetry around the z -axis. There are two such graphs among those depicted in the figure in the text: I and V. The one corresponding to $z = \frac{1}{x^2 + y^2}$ is I since the function blows up as (x, y) gets close to $(0, 0)$.
 (b) For similar reasons as in part (a), the graph is circularly symmetric about the z -axis, hence the corresponding one must be V.
 (c) The graph has to be a plane, hence IV.
 (d) The function is independent of x , hence the corresponding graph can only be II. Notice that the cross-sections of this graph parallel to the yz -plane are parabolas, which is a confirmation of the result.
 (e) The graph of this function is depicted in III. The picture shows the cross-sections parallel to the xz -plane, which have the shape of the cubic curves $z = x^3 - \text{constant}$.

4. The graph is a horizontal plane 3 units above the xy -plane. See Figure 12.15.

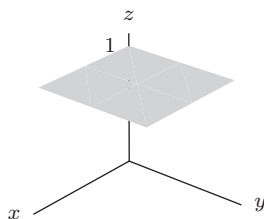

Figure 12.15

5. The graph is a sphere of radius 3, centered at the origin. See Figure 12.16.

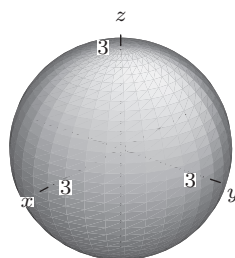

Figure 12.16

6. The graph is a bowl opening up, with vertex at the point $(0, 0, 4)$. See Figure 12.17.

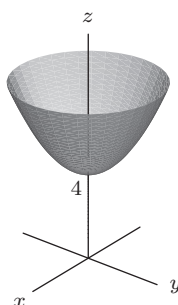

Figure 12.17

7. Since $z = 5 - (x^2 + y^2)$, the graph is an upside-down bowl moved up 5 units and with vertex at $(0, 0, 5)$. See Figure 12.18.

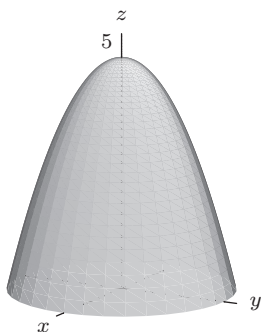

Figure 12.18

8. In the yz -plane, the graph is a parabola opening up. Since there are no restrictions on x , we extend this parabola along the x -axis. The graph is a parabolic cylinder opening up, extended along the x -axis. See Figure 12.19.

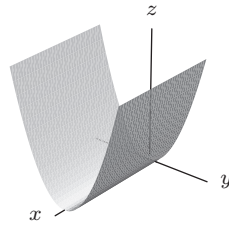

Figure 12.19

9. The graph is a plane with x -intercept 6, and y -intercept 3, and z -intercept 4. See Figure 12.20.

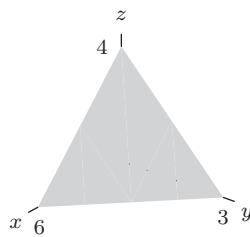

Figure 12.20

10. In the xy -plane, the graph is a circle of radius 2. Since there are no restrictions on z , we extend this circle along the z -axis. The graph is a circular cylinder extended in the z -direction. See Figure 12.21.

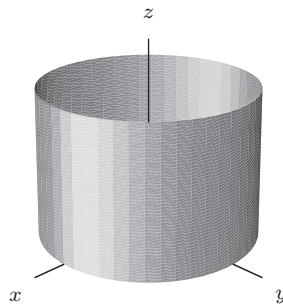

Figure 12.21

11. In the xz -plane, the graph is a circle of radius 2. Since there are no restrictions on y , we extend this circle along the y -axis. The graph is a circular cylinder extended in the y -direction. See Figure 12.22.

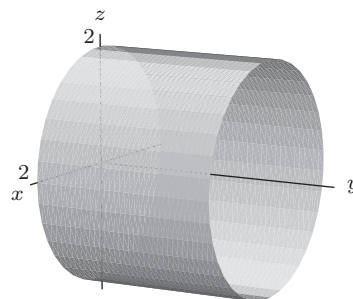

Figure 12.22

12. All the points on the cylinder are at a distance $\sqrt{7}$ from the y -axis. Since this distance is given by $\sqrt{x^2 + z^2}$, we have

$$\begin{aligned}\sqrt{x^2 + z^2} &= \sqrt{7} \\ x^2 + z^2 &= 7.\end{aligned}$$

13. A sphere of radius 3 centered at the origin has equation $x^2 + y^2 + z^2 = 3^2 = 9$, so shifting the center to $(0, \sqrt{7}, 0)$ gives

$$x^2 + (y - \sqrt{7})^2 + z^2 = 9.$$

14. A paraboloid with vertex at the origin but opening along the positive x -axis is

$$x = y^2 + z^2.$$

A parabola opening toward the negative x -axis is

$$x = -y^2 - z^2$$

so moving the vertex to $(1, 3, 5)$ gives

$$x = 1 - (y - 3)^2 - (z - 5)^2.$$

Problems

15. (a) Cross-sections with x fixed at $x = b$ are in Figure 12.23.

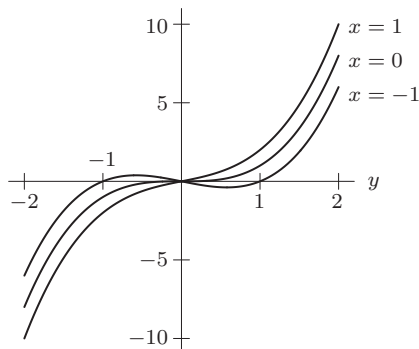

Figure 12.23: Cross-section $f(a, y) = y^3 + ay$, with $a = -1, 0, 1$

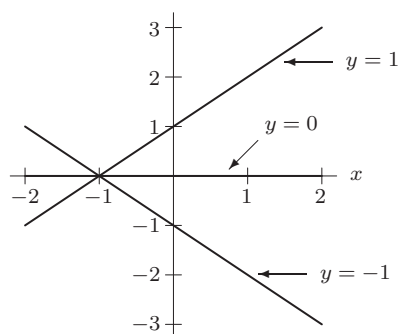

Figure 12.24: Cross-section $f(x, b) = b^3 + bx$, with $b = -1, 0, 1$

- (b) Cross-section with y fixed at $y = 6$ are in Figure 12.24.

16. We have $f(3, 2) = 2e^{-2(5-3)} = 0.037$. We see that 2 hours after the injection of 3 mg of this drug, the concentration of the drug in the blood is 0.037 mg per liter.

17. (a) Holding x fixed at 4 means that we are considering an injection of 4 mg of the drug; letting t vary means we are watching the effect of this dose as time passes. Thus the function $f(4, t)$ describes the concentration of the drug in the blood resulting from a 4 mg injection as a function of time. Figure 12.25 shows the graph of $f(4, t) = te^{-t}$. Notice that the concentration in the blood from this dose is at a maximum at 1 hour after injection, and that the concentration in the blood eventually approaches zero.

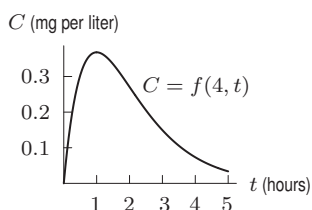

Figure 12.25: The function $f(4, t)$ shows the concentration in the blood resulting from a 4 mg injection

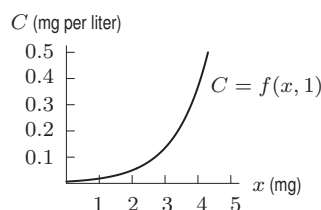

Figure 12.26: The function $f(x, 1)$ shows the concentration in the blood 1 hour after the injection

- (b) Holding t fixed at 1 means that we are focusing on the blood 1 hour after the injection; letting x vary means we are considering the effect of different doses at that instant. Thus, the function $f(x, 1)$ gives the concentration of the drug in the blood 1 hour after injection as a function of the amount injected. Figure 12.26 shows the graph of $f(x, 1) = e^{-(5-x)} = e^{x-5}$. Notice that $f(x, 1)$ is an increasing function of x . This makes sense: If we administer more of the drug, the concentration in the bloodstream is higher.
18. The one-variable function $f(a, t)$ represents the effect of an injection of a mg at time t . Figure 12.27 shows the graphs of the four functions $f(1, t) = te^{-4t}$, $f(2, t) = te^{-3t}$, $f(3, t) = te^{-2t}$, and $f(4, t) = te^{-t}$ corresponding to injections of 1, 2, 3, and 4 mg of the drug. The general shape of the graph is the same in every case: The concentration in the blood is zero at the time of injection $t = 0$, then increases to a maximum value, and then decreases toward zero again. We see that if a larger dose of the drug is administered, the peak of the graph is later and higher. This makes sense, since a larger dose will take longer to diffuse fully into the bloodstream and will produce a higher concentration when it does.

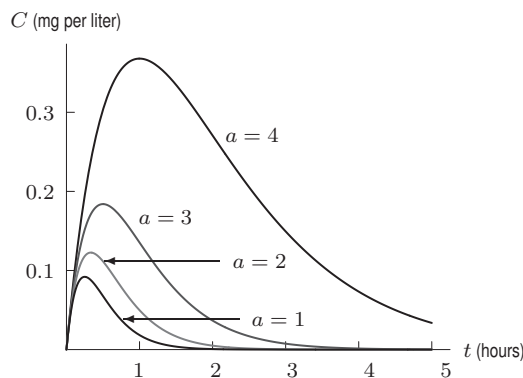

Figure 12.27: Concentration $C = f(a, t)$ of the drug resulting from an a mg injection

19. (a) is (IV), (b) is (IX), (c) is (VII), (d) is (I), (e) is (VIII), (f) is (II), (g) is (VI), (h) is (III), (i) is (V).
20. (a) This is a bowl; z increases as the distance from the origin increases, from a minimum of 0 at $x = y = 0$.
 (b) Neither. This is an upside-down bowl. This function decreases from 1, at $x = y = 0$, to arbitrarily large negative values as x and y increase due to the negative squared terms of x and y . It looks like the bowl in part (a) except flipped over and raised up slightly.
 (c) This is a plate. Solving the equation for z gives $z = 1 - x - y$ which describes a plane whose x and y slopes are -1 . It is perfectly flat, but not horizontal.
 (d) Within its domain, this function is a bowl. It is undefined at points at which $x^2 + y^2 > 5$, but within those limits it describes the bottom half of a sphere of radius $\sqrt{5}$ centered at the origin.
 (e) This function is a plate. It is perfectly flat and horizontal.
21. (a)

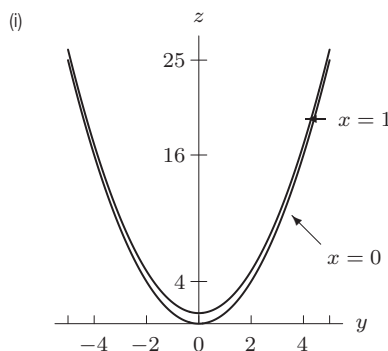

Figure 12.30: Cross-sections of $z = x^2 + y^2$

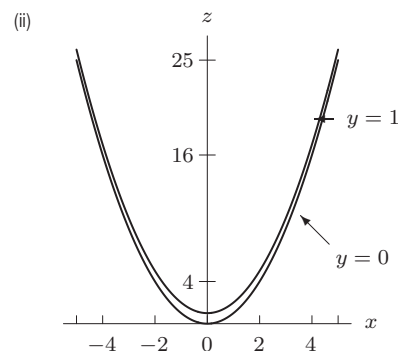

Figure 12.31: Cross-sections of $z = x^2 + y^2$

(b)

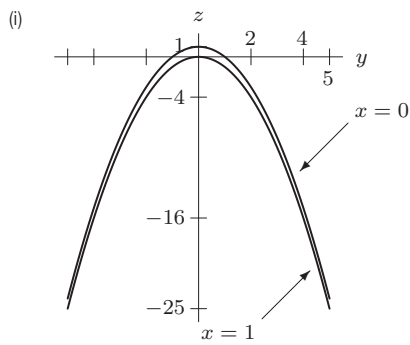

Figure 12.34: Cross-sections of $z = 1 - x^2 - y^2$

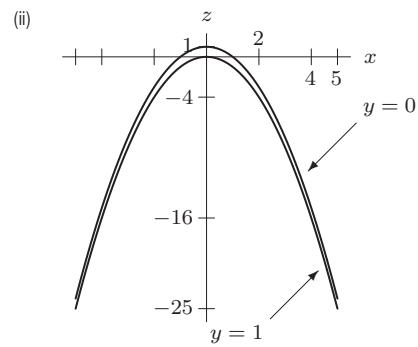

Figure 12.35: Cross-sections of $z = 1 - x^2 - y^2$

(c)

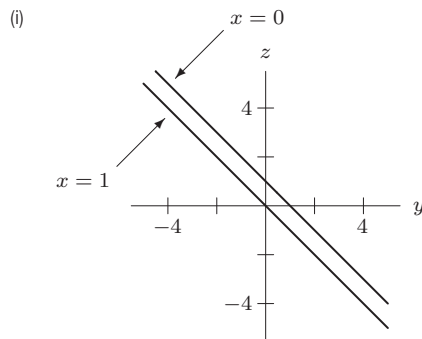

Figure 12.38: Cross-sections of $x + y + z = 1$

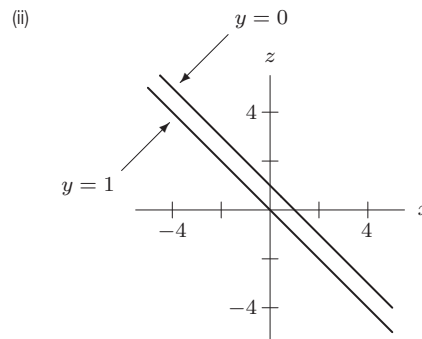

Figure 12.39: Cross-sections of $x + y + z = 1$

(d)

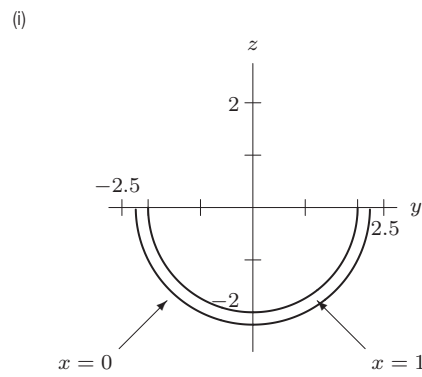

Figure 12.42: Cross-sections of $z = -\sqrt{5 - x^2 - y^2}$

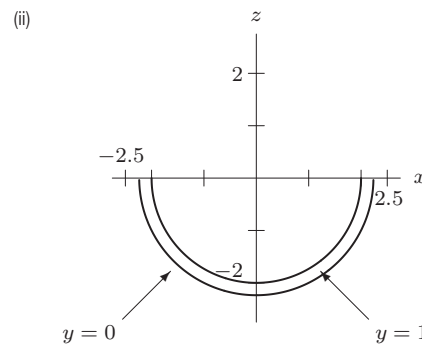
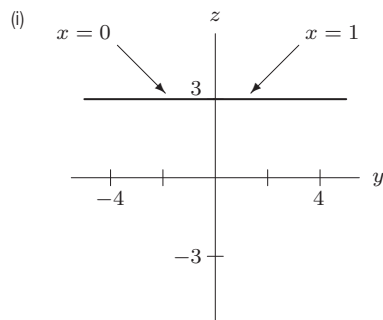
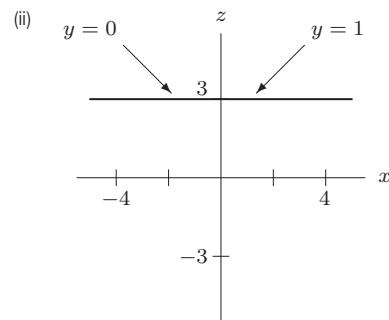

Figure 12.43: Cross-sections of $z = -\sqrt{5 - x^2 - y^2}$

(e)

Figure 12.46: Cross-section of $z = 3$ Figure 12.47: Cross-section of $z = 3$

22. (a) If we have iron stomachs and can consume cola and pizza endlessly without ill effects, then we expect our happiness to increase without bound as we get more cola and pizza. Graph (IV) shows this since it increases along both the pizza and cola axes throughout.
- (b) If we get sick upon eating too many pizzas or drinking too much cola, then we expect our happiness to decrease once either or both of those quantities grows past some optimum value. This is depicted in graph (I) which increases along both axes until a peak is reached, and then decreases along both axes.
- (c) If we do get sick after too much cola, but are always able to eat more pizza, then we expect our happiness to decrease after we drink some optimum amount of cola, but continue to increase as we get more pizza. This is shown by graph (III) which increases continuously along the pizza axis but, after reaching a maximum, begins to decrease along the cola axis.
23. One possible equation: $z = x^2 + y^2 + 5$. See Figure 12.48.

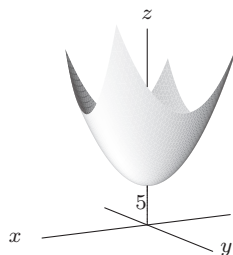

Figure 12.48

24. One possible equation: $x + y + z = 1$. See Figure 12.49.

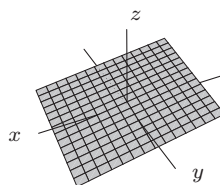

Figure 12.49

25. One possible equation: $z = (x - y)^2$. See Figure 12.50.

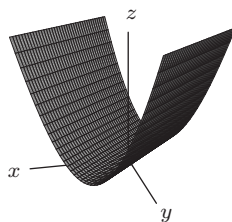

Figure 12.50

26. One possible equation: $z = -\sqrt{x^2 + y^2}$. See Figure 12.51.

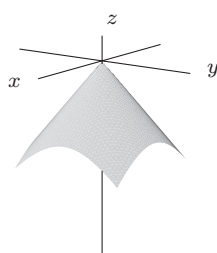

Figure 12.51

27. When h is fixed, say $h = 1$, then

$$V = f(r, 1) = \pi r^2 1 = \pi r^2$$

Similarly,

$$f(r, \frac{2}{3}) = \frac{4}{9}\pi r^2 \quad \text{and} \quad f(r, \frac{1}{3}) = \frac{\pi}{9}r^2$$

When r is fixed, say $r = 1$, then

$$f(1, h) = \pi(1)^2 h = \pi h$$

Similarly,

$$f(2, h) = 4\pi \quad \text{and} \quad f(3, h) = 9\pi h.$$

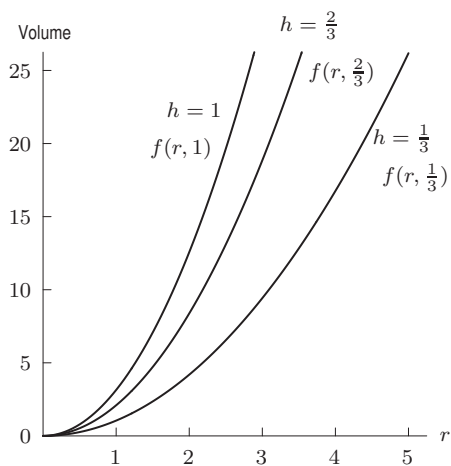

Figure 12.52

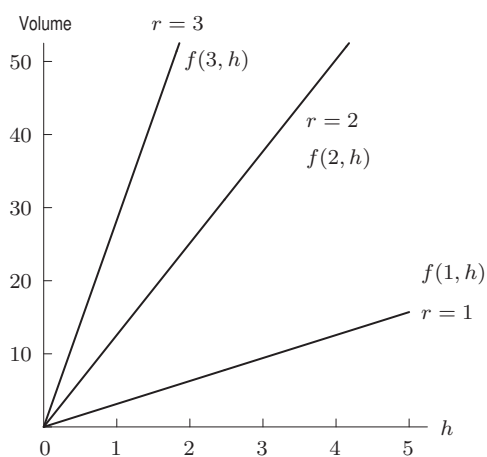

Figure 12.53

28. (a) The plane $y = 0$ intersects the graph in the curve $z = 4x^2 + 1$, which is a parabola opening upward.
 (b) The plane $x = 0$ intersects the graph in $z = -y^2 + 1$, which is a parabola opening downward because of the negative coefficient of y^2 .
 (c) The plane $z = 1$ intersects the graph in $4x^2 - y^2 = 0$. Since this factors as $(2x - y)(2x + y) = 0$, it is the equation for the two lines $y = 2x$ and $y = -2x$.

29.

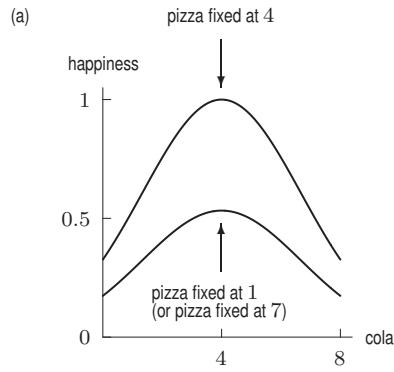

Figure 12.54: Cross-sections of graph I

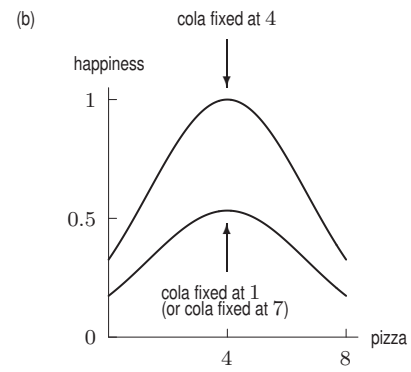

Figure 12.55: Cross-sections of graph I

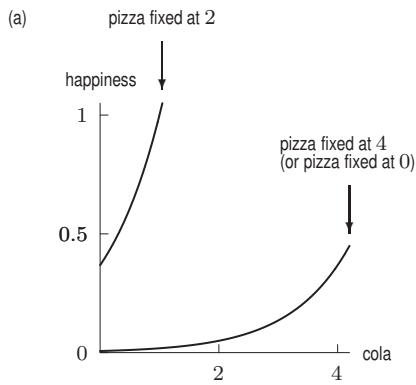

Figure 12.56: Cross-sections of graph II

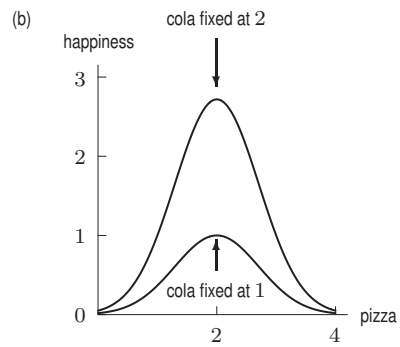

Figure 12.57: Cross-sections of graph II

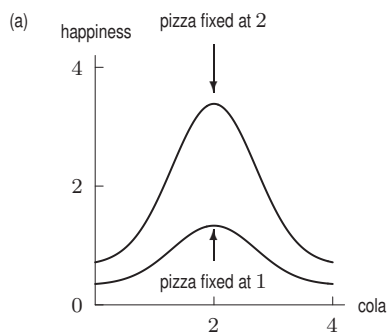

Figure 12.58: Cross-sections of graph III

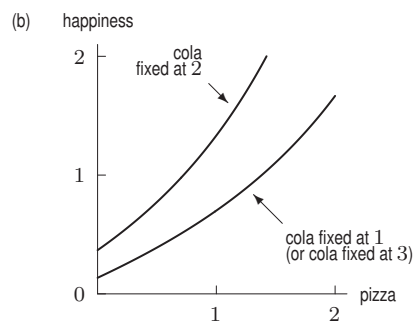

Figure 12.59: Cross-sections of graph III

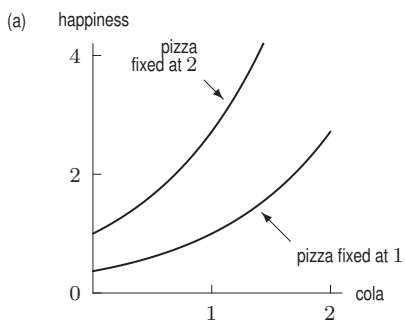

Figure 12.60: Cross-sections of graph IV

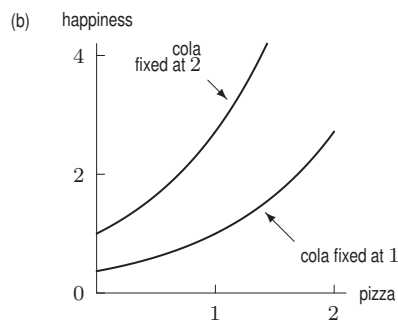

Figure 12.61: Cross-sections of graph IV

30. (a) Figures 12.62-12.65 show the wave profile at time $t = -1, 0, 1, 2$.

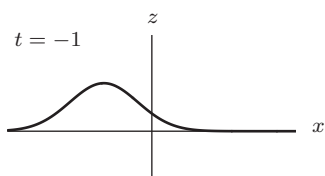

Figure 12.62

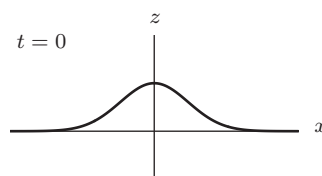

Figure 12.63

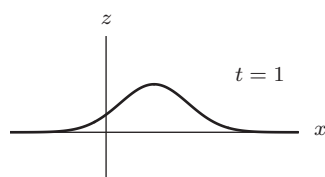

Figure 12.64

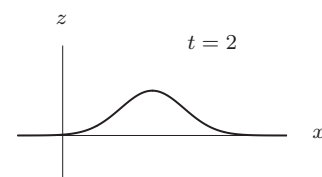

Figure 12.65

(b) Increasing x

(c) The graph in Figure 12.66 represents a wave traveling in the opposite direction.

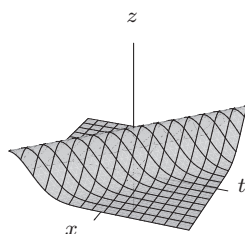

Figure 12.66

31. (a) Cross-sections with t fixed are in Figure 12.67. The equations are

$$f(x, 0) = \cos 0 \sin x = \sin x,$$

$$f(x, \pi/4) = \cos(\pi/4) \sin x = \frac{1}{\sqrt{2}} \sin x.$$

Cross-sections with t fixed are in Figure 12.68. The equations are

$$f(\pi/4, t) = \cos t \sin(\pi/4) = \frac{1}{\sqrt{2}} \cos t,$$

$$f(\pi/2, t) = \cos t \sin(\pi/2) = \cos t.$$

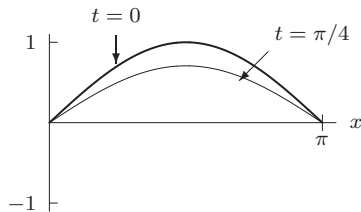

Figure 12.67: Cross-sections with t fixed

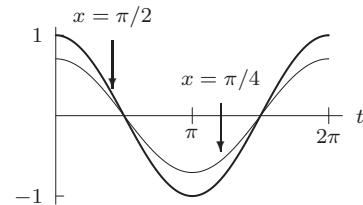

Figure 12.68: Cross-sections with x fixed

- (b) If $x = 0, \pi$, then $f(0, t) = \cos t \cdot \sin 0 = 0 = f(\pi, t)$. The ends of the string are at $x = 0, \pi$, which do not move so the displacement is 0 there for all t .
- (c) The cross-sections with t fixed are snapshots of the string at different instants in time. Graphs of these cross-sections are the curves obtained when the the graph of f in Figure 12.69 is sliced perpendicular to the t axis. Every plane perpendicular to the t -axis intersects the surface in one arch of a sine curve. The amplitude of the arch changes with t as a cosine curve.

The cross-sections with x fixed show how a single point on the string moves as time goes by. Graphs of these cross-sections are obtained by slicing the graph perpendicular to the x axis. Notice in Figure 12.69 that the cross-sections with $x = 0$ and $x = \pi$ are flat lines since the endpoints of the string don't move. The cross-section with $x = \pi/2$ is a cosine curve with amplitude 1, because the midpoint of the string oscillates back and forth. Cross-sections with x fixed between 0 and $\pi/2$ and between $\pi/2$ and π are cosine curves with amplitude between 0 and 1, representing the fact that these points on the string oscillate back and forth with the same period as $x = \pi/2$, but a smaller amplitude.

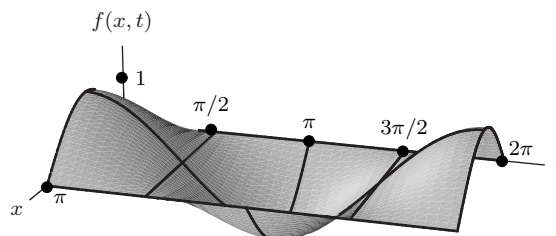

Figure 12.69: Graph of vibrating string function
 $f(x, t) = \cos t \sin x$

Strengthen Your Understanding

32. The graph of a function $f(x, y)$ is a parabolic surface in 3-space, not a circle.
33. If we hold x fixed, then $z = f(x, y) = x^2$ is also fixed, so the cross-section is a line parallel to the y -axis.
34. We know that $z = x^2 + y^2 + 2$ is positive everywhere and that the surface intersects the plane $z = 2$ only at $(0, 0, 2)$. So let $f(x, y) = x^2 + y^2 + 2$.
35. The function $f(x, y) = x^2 - 1$ intersects the xz -plane (and any plane parallel to the xz -plane) in the parabola $z = x^2 - 1$. It also intersect the yz -plane in the line $z = -1$. So f is a possible example. The function $g(x, y) = x^2 + y$ intersects the xz -plane in the parabola $z = x^2$ and the yz -plane in the line $y = z$. So g is another possible example. There are many others.
36. The function $f(x, y) = 1 - x^2 - y^2$ intersects the xy -plane in the circle $x^2 + y^2 = 1$. So f is a possible example. There are many others.

37. False. Fixing $w = k$ gives the one-variable function $g(v) = e^v/k$, which is an increasing exponential function if $k > 0$, but is decreasing if $k < 0$.
38. True. For example, consider the weekly beef consumption C of a household as a function of total income I and the cost of beef per pound p . It is possible that consumption increases as income increases (for fixed p) and consumption decreases as the price of beef increases (for fixed I).
39. True. For example, consider $f(x, y) = e^x \cdot (6 - y)$. Then $g(x) = f(x, 5) = e^x$, which is an increasing function of x . On the other hand, $h(x) = f(x, 10) = -4e^x$, which is a decreasing function of x .
40. False. The point $(0, 0, 0)$ does not satisfy the equation.
41. True. The x -axis is where $y = z = 0$.
42. False. If $x = 10$, substituting gives $10^2 + y^2 + z^2 = 10$, so $y^2 + z^2 = -90$. Since $y^2 + z^2$ cannot be negative, a point with $x = 10$ cannot satisfy the equation.
43. True. The cross-section with $y = 1$ is the line $z = x + 1$.
44. True. The cross-sections with $x = c$ are all of the form $z = 1 - y^2$.
45. True. The cross-sections with $y = c$ are of the form $z = 1 - c^2$, which are horizontal lines.
46. True. For any a and b , we have $f(a, b) \neq g(a, b)$. The graph of g is same as the graph of f , except it is shifted 2 units vertically.
47. True. The intersection, where $f(x, y) = g(x, y)$, is given by $x^2 + y^2 = 1 - x^2 - y^2$, or $x^2 + y^2 = 1/2$. This is a circle of radius $1/\sqrt{2}$ parallel to the xy -plane at height $z = 1/2$.
48. False. For example, $f(x, y) = x^2$ (or any cylinder along the y -axis) is not a plane but has lines for $x = c$ cross-sections.
49. False. Wherever $f(x, y) = 0$ the graphs of $f(x, y)$ and $-f(x, y)$ will intersect.
50. True. The graph is the bowl-shaped $g(x, y) = x^2 + y^2$ turned upside-down and shifted upward by 10 units.
51. (c), a plane. While x is fixed at 2, y and z can vary freely.

Solutions for Section 12.3

Exercises

1. We'll set $z = 4$ at the peak. See Figure 12.70.

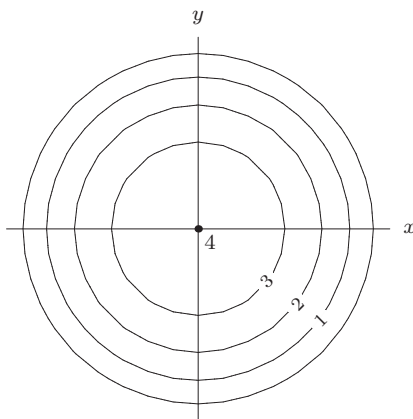

Figure 12.70

2. See Figure 12.71.

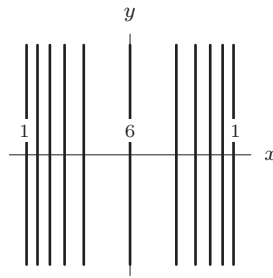

Figure 12.71

3. We will take $z = 4$ to be the flat area. See Figure 12.72.

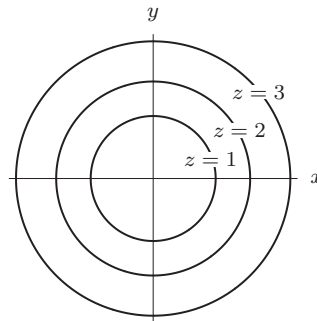

Figure 12.72

4. See Figure 12.73.

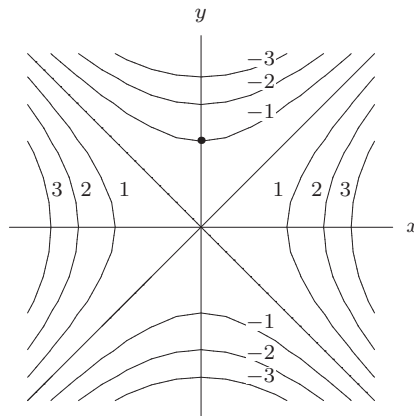

Figure 12.73

5. The contour where $f(x, y) = x + y = c$, or $y = -x + c$, is the graph of the straight line with slope -1 as shown in Figure 12.74. Note that we have plotted the contours for $c = -3, -2, -1, 0, 1, 2, 3$. The contours are evenly spaced.

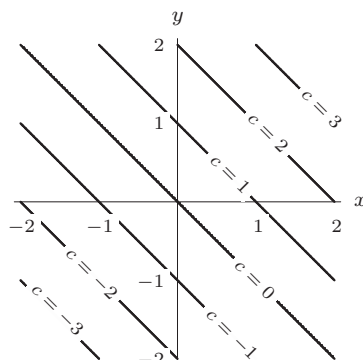

Figure 12.74

6. The contour where $f(x, y) = 3x + 3y = c$ or $y = -x + c/3$ is the graph of the straight line of slope -1 as shown in Figure 12.75. Note that we have plotted the contours for $c = -9, -6, -3, 0, 3, 6, 9$. The contours are evenly spaced.

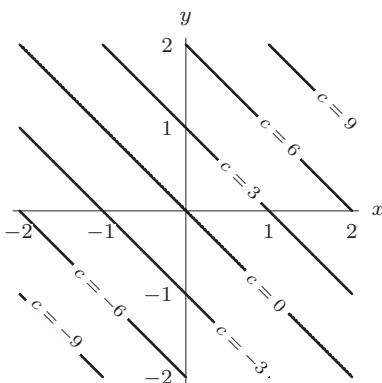

Figure 12.75

7. The contour where $f(x, y) = x^2 + y^2 = c$, where $c \geq 0$, is the graph of the circle centered at $(0, 0)$, with radius \sqrt{c} as shown in Figure 12.76. Note that we have plotted the contours for $c = 0, 1, 2, 3, 4$. The contours become more closely packed as we move further from the origin.

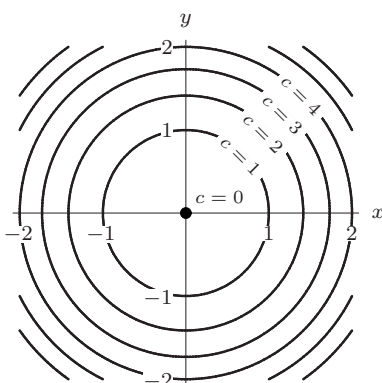

Figure 12.76

8. The contour where $f(x, y) = -x^2 - y^2 + 1 = c$, where $c \leq 1$, is the graph of the circle centered at $(0, 0)$, with radius $\sqrt{1 - c}$ as shown in Figure 12.77. Note that we have plotted the contours for $c = -3, -2, -1, 0, 1$. The contours become more closely packed as we move further from the origin.

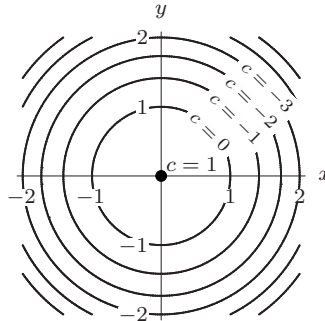

Figure 12.77

9. The contour where $f(x, y) = xy = c$, is the graph of the hyperbola $y = c/x$ if $c \neq 0$ and the coordinate axes if $c = 0$, as shown in Figure 12.78. Note that we have plotted contours for $c = -5, -4, -3, -2, -1, 0, 1, 2, 3, 4, 5$. The contours become more closely packed as we move further from the origin.

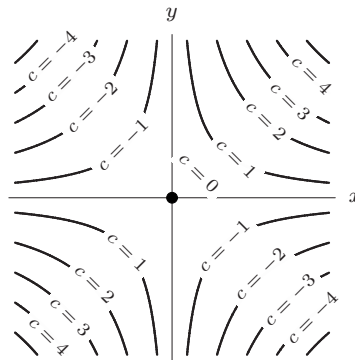

Figure 12.78

10. The contour where $f(x, y) = y - x^2 = c$ is the graph of the parabola $y = x^2 + c$, with vertex $(0, c)$ and symmetric about the y -axis, shown in Figure 12.79. Note that we have plotted the contours for $c = -2, -1, 0, 1$. The contours become more closely packed as we move farther from the y -axis.

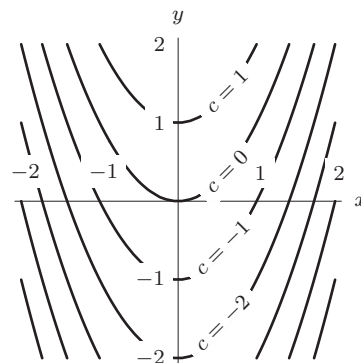

Figure 12.79

11. The contour where $f(x, y) = x^2 + 2y^2 = c$, where $c \geq 0$, is the graph of the ellipse with foci $(-\sqrt{\frac{c}{2}}, 0)$, $(\sqrt{\frac{c}{2}}, 0)$ and axes lying on x - and y -axes as shown in Figure 12.80. Note that we have plotted the contours for $c = 0, 1, 2, 3, 4$. The contours become more closely packed as we move further from the origin.

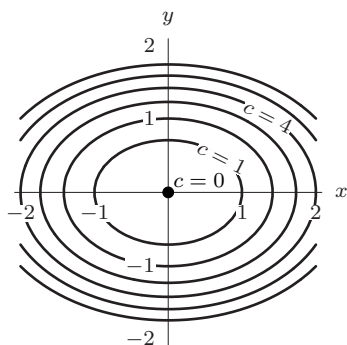

Figure 12.80

12. The contour where $f(x, y) = \sqrt{x^2 + 2y^2} = c$, where $c \geq 0$, is the graph of the ellipse with foci $(-\frac{c\sqrt{2}}{2}, 0)$, $(\frac{c\sqrt{2}}{2}, 0)$ and axes lying on x - and y -axes as shown in Figure 12.81. Note that we have plotted the contours for $c = 0, 1, 2, 3, 4$. See Figure 12.81.

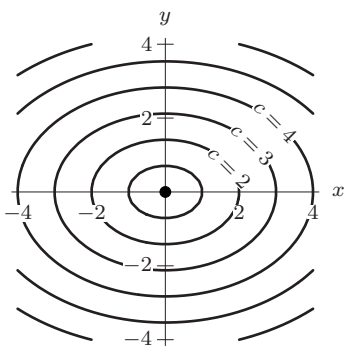

Figure 12.81

13. The contour where $f(x, y) = \cos(\sqrt{x^2 + y^2}) = c$, where $-1 \leq c \leq 1$, is a set of circles centered at $(0, 0)$, with radius $\cos^{-1} c + 2k\pi$ with $k = 0, 1, 2, \dots$ and $-\cos^{-1} c + 2k\pi$, with $k = 1, 2, 3, \dots$ as shown in Figure 12.82. Note that we have plotted contours for $c = 0, 0.2, 0.4, 0.6, 0.8, 1$.

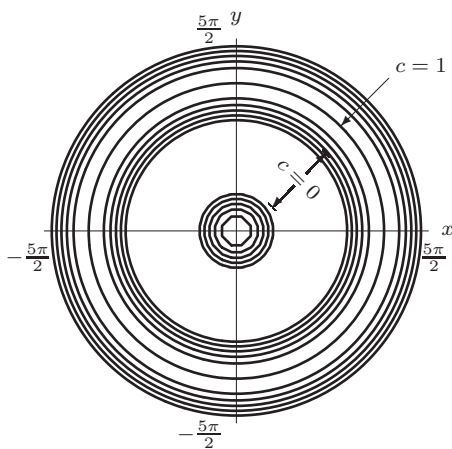

Figure 12.82

14. Since $f(5, 10) = 3 \cdot 5^2 \cdot 10 + 7 \cdot 5 + 20 = 805$, an equation for the contour is

$$3x^2y + 7x + 20 = 805.$$

15. (a) Level curves are in Figure 12.83.

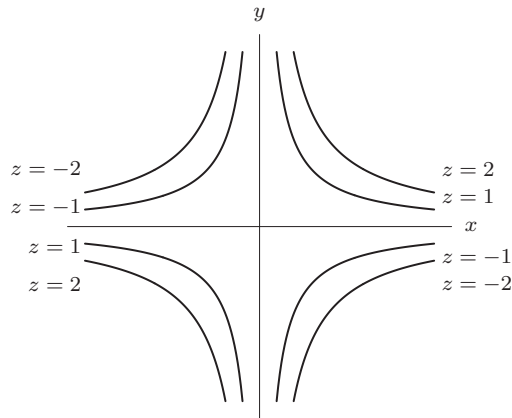

Figure 12.83

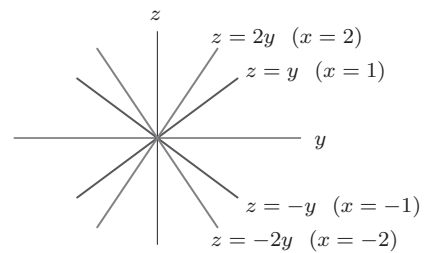

Figure 12.84

- (b) Cross-sections with x constant are in Figure 12.84
- (c) Setting $y = x$ gives the curve $z = x^2$ in Figure 12.85

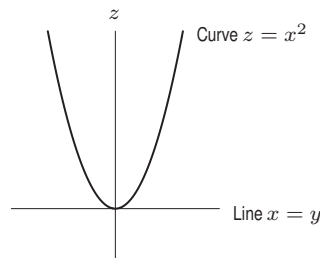

Figure 12.85

- 16. (a) (III)
 (b) (I)
 (c) (V)
 (d) (II)
 (e) (IV)
- 17. The values in Table 12.5 are not constant along rows or columns and therefore cannot be the lines shown in (I) or (IV). Also observe that as you move away from the origin, whose contour value is 0, the z -values on the contours increase. Thus, this table corresponds to diagram (II).
 The values in Table 12.6 are also not constant along rows or columns. Since the contour values are decreasing as you move away from the origin, this table corresponds to diagram (III).
 Table 12.7 shows that for each fixed value of x , we have constant contour value, suggesting a straight vertical line at each x -value, as in diagram (IV).
 Table 12.8 also shows lines, however these are horizontal since for each fixed value of y we have constant contour values. Thus, this table matches diagram (I).
- 18. Superimposing the surface $z = 1/2$ on the graph of $f(x, y)$ gives Figure 12.86. The contour $f(x, y) = 1/2$ is the intersection of the two surfaces; that is, the collection of closed curves as shown in Figure 12.87

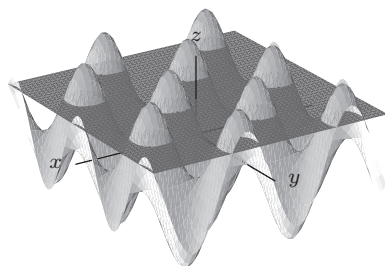

Figure 12.86

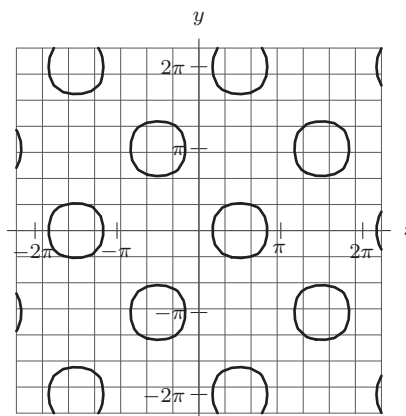

Figure 12.87

Problems

19. We expect total sales to decrease as the price increases and to increase as advertising expenditures increase. Moving parallel to the x -axis, the Q -values on the contours decrease, whereas moving parallel to the y -axis, the Q -values increase. Thus, x is the price and y is advertising expenditures

20. To find a value, evaluate $f(x, y) = 100e^x - 50y^2$ at any point (x, y) on the contour. Check by evaluating the function at a couple of points on each contour. Starting from the left and estimating points on the contour, we have

- First contour: $f(0, 0) = 100, f(0.2, 0.65) = 101$
- Second contour: $f(0.4, 0) = 149, f(0.6, 0.8) = 150$
- Third contour: $f(0.7, 0) = 201, f(0.8, 0.65) = 201$
- Fourth contour: $f(0.92, 0) = 251, f(1, 0.65) = 251$.

Since the true values of f are equally spaced multiples of 10, it seems that they must be 100, 150, 200, and 250. See Figure 12.88.

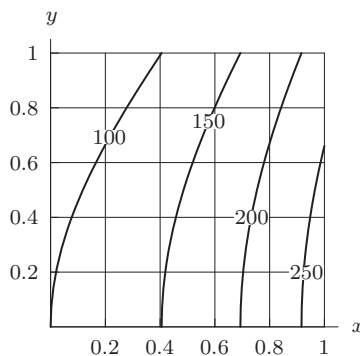

Figure 12.88

21. (a) We have

$$f(x, y) = x^2 - y^2 - 2x + 4y - 3 = (x - 1)^2 - (y - 2)^2.$$

Thus, the graph of f has the same saddle shape as that of $z = x^2 - y^2$ but centered at $x = 1, y = 2$. The function increases in the x -direction and decreases in the y -direction, so f corresponds to III.

(b) We have

$$g(x, y) = x^2 + y^2 - 2x - 4y + 15 = (x - 1)^2 + (y - 2)^2 + 10.$$

Thus, the graph of g is a paraboloid opening upward, with vertex at $(1, 2, 10)$. So h corresponds to VI.

(c) We have

$$h(x, y) = -x^2 - y^2 + 2x + 4y - 8 = -(x - 1)^2 - (y - 2)^2 - 3.$$

Thus, the graph of h is a paraboloid opening downward, with vertex at $(1, 2, -3)$. So h corresponds to I.

(d) We have

$$j(x, y) = -x^2 + y^2 + 2x - 4y + 3 = -(x - 1)^2 + (y - 2)^2.$$

Thus, the graph of j has the same saddle shape as that of $z = -x^2 + y^2$ but centered at $x = 1, y = 2$. The function decreases in the x -direction and increases in the y -direction, so j corresponds to IV.

(e) Since $k(x, y) = \sqrt{(x - 1)^2 + (y - 2)^2}$, the graph of k is a cone opening upward with vertex at $(1, 2, 0)$. Thus, the graph of k corresponds to II.

(f) Since $l(x, y) = -\sqrt{(x - 1)^2 + (y - 2)^2}$, the graph of l is a cone opening downward with vertex at $(1, 2, 0)$. Thus, the graph of l corresponds to V.

22. (a) Find the point where the horizontal line for 15 mph meets the contour for -20°F wind chill. The actual temperature is about 0°F .
 (b) The horizontal line for 10 mph meets the vertical line for 0°F about $1/5$ of the way from the contour for -20°F to the contour for 0°F wind chill. We estimate the wind chill to be about -16°F .
 (c) We look for the point on the vertical line for -20°F where the wind chill is -50°F , the danger point for humans. This is a point on the line that is about half way between the contours for -60°F and -40°F . The point can not be determined exactly, but we estimate that it occurs where the wind speed is about 23 mph.
 (d) A temperature drop of 20°F corresponds to moving left from one vertical grid line to the next on the horizontal line for 15 mph. This horizontal movement appears to correspond to about $1\ 1/4$ the horizontal distance between contours crossing the line. Since contours are spaced at 20°F wind chill, we estimate that the wind chill drops about 25°F when the air temperature goes down 20°F during a 15 mph wind.
23. To sketch the curve, first put dots on the point where an f contour crosses a g contour of the same value. Then connect the dots with a smooth curve. See Figure 12.89.

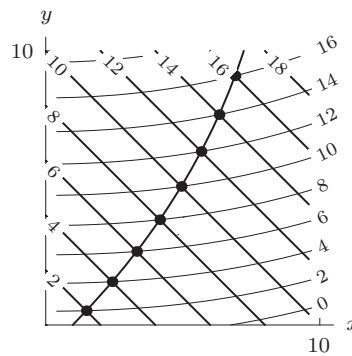

Figure 12.89: Black: $f(x, y)$. Blue: $g(x, y)$

24. Many different answers are possible. Answers are in degrees Celsius.

(a) Minnesota in winter. See Figure 12.90.

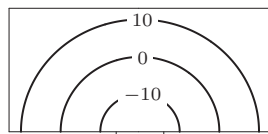

Figure 12.90

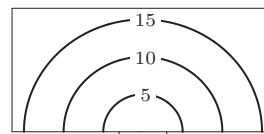

Figure 12.91

(b) San Francisco in winter. See Figure 12.91.

(c) Houston in summer. See Figure 12.92.

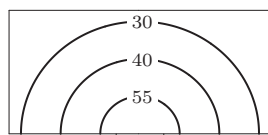

Figure 12.92

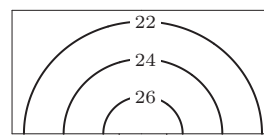

Figure 12.93

- (d) Oregon in summer. See Figure 12.93.
25. The point $x = 10, t = 5$ is between the contours $H = 70$ and $H = 75$, a little closer to the former. Therefore, we estimate $H(10, 5) \approx 72$, i.e., it is about 72°F . Five minutes later we are at the point $x = 10, t = 10$, which is just above the contour $H = 75$, so we estimate that it has warmed up to 76°F by then.
26. The line $t = 5$ crosses the contour $H = 80$ at about $x = 4$; this means that $H(4, 5) \approx 80$, and so the point $(4, 80)$ is on the graph of the one-variable function $y = H(x, 5)$. Each time the line crosses a contour, we can plot another point on the graph of $H(x, 5)$, and thus get a sketch of the graph. See Figure 12.94. Each data point obtained from the contour map has been indicated by a dot on the graph. The graph of $H(x, 20)$ was obtained in a similar way.

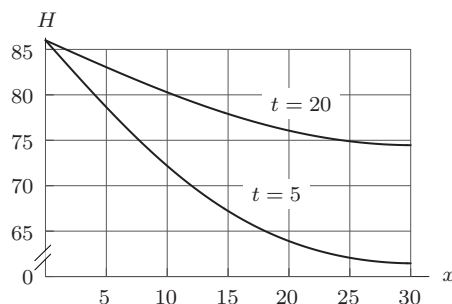

Figure 12.94: Graph of $H(x, 5)$ and $H(x, 20)$: heat as a function of distance from the heater at $t = 5$ and $t = 20$ minutes

These two graphs describe the temperature at different positions as a function of x for $t = 5$ and $t = 20$.

Notice that the graph of $H(x, 5)$ descends more steeply than the graph of $H(x, 20)$; this is because the contours are quite close together along the line $t = 5$, whereas they are more spread out along the line $t = 20$. In practical terms the shape of the graph of $H(x, 5)$ tells us that the temperature drops quickly as you move away from the heater, which makes sense, since the heater was turned on just five minutes ago. On the other hand, the graph of $H(x, 20)$ descends more slowly, which makes sense, because the heater has been on for 20 minutes and the heat has had time to diffuse throughout the room.

27. (a) The contour lines are much closer together on path A , so path A is steeper.
 (b) If you are on path A and turn around to look at the countryside, you find hills to your left and right, obscuring the view. But the ground falls away on either side of path B , so you are likely to get a much better view of the countryside from path B .
 (c) There is more likely to be a stream alongside path A , because water follows the direction of steepest descent.
28. (a) The point representing 13% and \$6000 on the graph lies between the 120 and 140 contours. We estimate the monthly payment to be about \$137.
 (b) Since the interest rate has dropped, we will be able to borrow more money and still make a monthly payment of \$137. To find out how much we can afford to borrow, we find where the interest rate of 11% intersects the \$137 contour and read off the loan amount to which these values correspond. Since the \$137 contour is not shown, we estimate its position from the \$120 and \$140 contours. We find that we can borrow an amount of money that is more than \$6000 but less than \$6500. So we can borrow about \$250 more without increasing the monthly payment.
 (c) The entries in the table will be the amount of loan at which each interest rate intersects the 137 contour. Using the \$137 contour from (b) we make table 12.11.

Table 12.11 Amount borrowed at a monthly payment of \$137.

Interest Rate (%)	0	1	2	3	4	5	6	7
Loan Amount (\$)	8200	8000	7800	7600	7400	7200	7000	6800
Interest rate (%)	8	9	10	11	12	13	14	15
Loan Amount (\$)	6650	6500	6350	6250	6100	6000	5900	5800

- (a) The point representing 8% and \$6000 on the graph lies between the 120 and 140 contours. We estimate the monthly payment to be about \$122.

- (b) Since the interest rate has dropped, we will be able to borrow more money and still make a monthly payment of \$122. To find out how much we can afford to borrow, we find where the interest rate of 6% intersects the \$122 contour and read off the loan amount to which these values correspond. Since the \$122 contour is not shown, we estimate its position from the \$120 and \$140 contours. We find that we can borrow an amount of money that is more than \$6000 but less than \$6500. So we can borrow about \$350 more without increasing the monthly payment.
- (c) The entries in the table will be the amount of loan at which each interest rate intersects the 122 contour. Using the \$122 contour from (b) we make table 12.12.

Table 12.12 Amount borrowed at a monthly payment of \$122.

Interest Rate (%)	0	1	2	3	4	5	6	7
Loan Amount (\$)	7400	7200	7000	6800	6650	6500	6350	6200
Interest rate (%)	8	9	10	11	12	13	14	15
Loan Amount (\$)	6000	5850	5700	5600	5500	5400	5300	5200

29. The vertical spacing between the contours just north and just south of the trail increases as you move eastward along the trail. A possible contour diagram is in Figure 12.95.

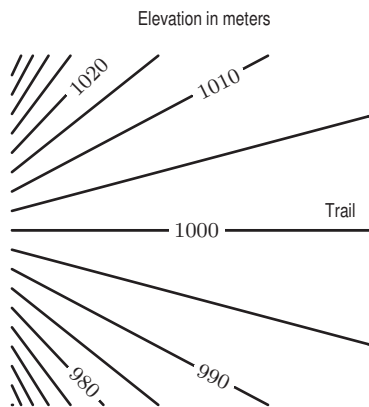

Figure 12.95

30. (a) I
 (b) IV
 (c) II
 (d) III

See Figure 12.96.

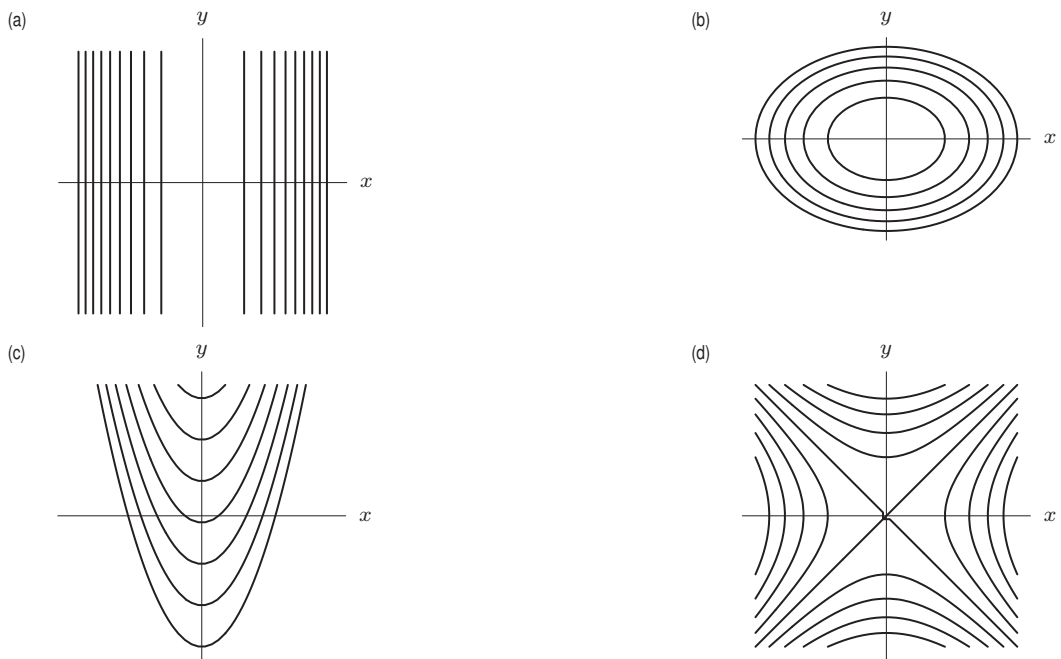

Figure 12.96

31. Figure 12.97 shows an east-west cross-section along the line $N = 50$ kilometers.
 Figure 12.98 shows an east-west cross-section along the line $N = 100$ kilometers.

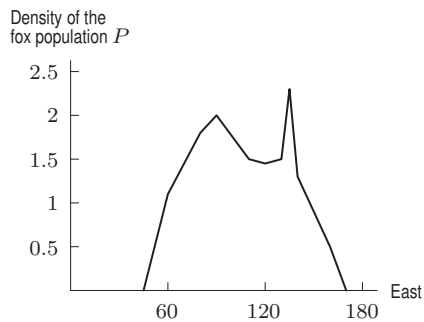

Figure 12.97

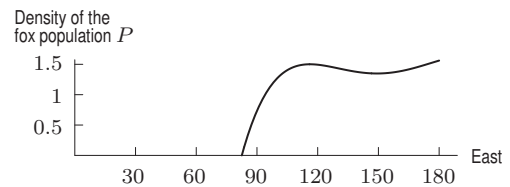

Figure 12.98

- Figure 12.99 shows a north-south cross-section along the line $E = 60$ kilometers.
 Figure 12.100 shows a north-south cross-section along the line $E = 120$ kilometers.

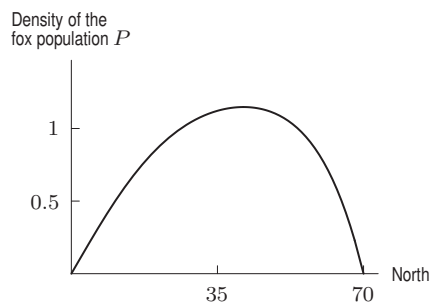

Figure 12.99

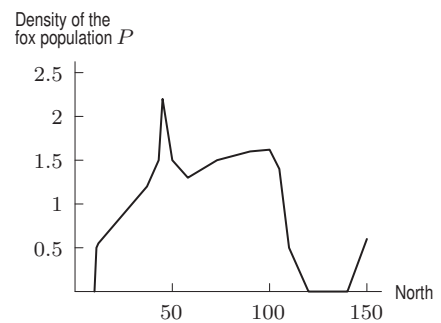

Figure 12.100

32. (a) The profit is given by the following:

$$\pi = \text{Revenue from } q_1 + \text{Revenue from } q_2 - \text{Cost.}$$

Measuring π in thousands, we obtain:

$$\pi = 3q_1 + 12q_2 - 4.$$

(b) A contour diagram of π follows. Note that the units of π are in thousands.

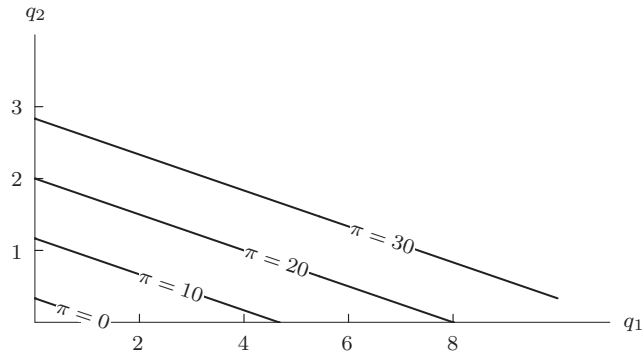

33. For any Cobb-Douglas function $F(K, L) = bL^\alpha K^\beta$, if we increase the inputs by a factor of m , from (K, L) to (mK, mL) we get:

$$\begin{aligned} F(mK, mL) &= b(mL)^\alpha (mK)^\beta \\ &= m^{\alpha+\beta} bL^\alpha K^\beta \\ &= m^{\alpha+\beta} F(K, L) \end{aligned}$$

Thus we see that increasing inputs by a factor of m increases outputs by a factor of $m^{\alpha+\beta}$.

If $\alpha + \beta < 1$, then increasing each input by a factor of m will result in an increase in output of less than a factor of m . This applies to statements (a) and (E). In statement (a), $\alpha + \beta = 0.25 + 0.25 = 0.5$, so increasing inputs by a factor of $m = 4$, as in statement (E), increases output by a factor of $4^{0.5} = 2$. We can match statements (a) and (E) to graph (II) by noting that when $(K, L) = (1, 1)$, we have $F = 1$ and when we double the inputs ($m = 2$) to $(K, L) = (2, 2)$, F increases by less than a factor of 2. This is called decreasing returns to scale.

If $\alpha + \beta = 1$, then increasing K and L by a factor of m will result in an increase in F by the same factor m . This applies to statements (b) and (D). In statement (b), $\alpha + \beta = 0.5 + 0.5 = 1$, and in statement (D), an increase in inputs by a factor of 3 results in an increase in F by the same factor. We match these statements to graph (I) where we see that increasing (K, L) from $(1, 1)$ to $(3, 3)$ results in an increase in F from $F = 1$ to $F = 3$. This is called constant returns to scale.

If $\alpha + \beta > 1$, then we have increasing returns to scale, i.e. an increase in K and L by a factor of m results in an increase in F by more than a factor of m . This is the case for equation (c), where $\alpha + \beta = 0.75 + 0.75 = 1.5$. Statement (G) also applies an increase in inputs by a factor of $m = 2$ results in an increase in output by more than 2, in this case by a factor of almost 3. We can match statements (c) and (G) to graph (III), where we see that increasing (K, L) from $(1, 1)$ to $(2, 2)$ results in a change in F by more than a factor of 2 (but less than a factor of 3). This is called increasing returns to scale.

This information is summarized in Table 12.13.

Table 12.13

Function	Graph	Statement
$F(L, K) = L^{0.25} K^{0.25}$	(II)	(E)
$F(L, K) = L^{0.5} K^{0.5}$	(I)	(D)
$F(L, K) = L^{0.75} K^{0.75}$	(III)	(G)

34. Suppose P_0 is the production given by L_0 and K_0 , so that

$$P_0 = f(L_0, K_0) = cL_0^\alpha K_0^\beta.$$

We want to know what happens to production if L_0 is increased to $2L_0$ and K_0 is increased to $2K_0$:

$$\begin{aligned} P &= f(2L_0, 2K_0) \\ &= c(2L_0)^\alpha (2K_0)^\beta \\ &= c2^\alpha L_0^\alpha 2^\beta K_0^\beta \\ &= 2^{\alpha+\beta} cL_0^\alpha K_0^\beta \\ &= 2^{\alpha+\beta} P_0. \end{aligned}$$

Thus, doubling L and K has the effect of multiplying P by $2^{\alpha+\beta}$. Notice that if $\alpha + \beta > 1$, then $2^{\alpha+\beta} > 2$, if $\alpha + \beta = 1$, then $2^{\alpha+\beta} = 2$, and if $\alpha + \beta < 1$, then $2^{\alpha+\beta} < 2$. Thus, $\alpha + \beta > 1$ gives increasing returns to scale, $\alpha + \beta = 1$ gives constant returns to scale, and $\alpha + \beta < 1$ gives decreasing returns to scale.

35. (a) If $f(x, y) = x^{0.2}y^{0.8} = c$, then solving for y gives

$$\begin{aligned} y^{0.8} &= \frac{c}{x^{0.2}} \\ y &= \left(\frac{c}{x^{0.2}}\right)^{1/0.8} = \frac{A}{x^{1/4}}. \end{aligned}$$

Here A is another constant, $A = c^{1/0.8}$.

Similarly, if $g(x, y) = x^{0.8}y^{0.2} = k$, then solving for y gives

$$\begin{aligned} y^{0.2} &= \frac{k}{x^{0.8}} \\ y &= \left(\frac{k}{x^{0.8}}\right)^{1/0.2} = \frac{B}{x^4}. \end{aligned}$$

Since the y -values in Figure (I) decay more quickly than those in Figure (II), we see that Figure (I) is $g(x, y)$ and Figure (II) is $f(x, y)$.

- (b) Since the y -values in Figure (III) decrease slower than in Figure (I) and faster than in Figure (II), we have $0.2 < \alpha < 0.8$.

36. Using the rules of logarithms on f and g gives

$$\begin{aligned} f(x, y) &= \ln(x^{0.7}y^{0.3}) \\ g(x, y) &= \ln(x^{0.3}y^{0.7}). \end{aligned}$$

Thus the level curves of f are of the form

$$\ln(x^{0.7}y^{0.3}) = c \quad \text{so} \quad x^{0.7}y^{0.3} = e^c = A \quad \text{or} \quad y = \frac{A^{1/0.3}}{x^{7/3}}.$$

The level curves of g are of the form

$$\ln(x^{0.3}y^{0.7}) = c \quad \text{so} \quad x^{0.3}y^{0.7} = e^c = A \quad \text{or} \quad y = \frac{A^{1/0.7}}{x^{3/7}}.$$

The level curves of h and j are ellipses. For any constant c , the level curve

$$h(x, y) = 0.3x^2 + 0.7y^2 = c$$

cuts the x -axis at $x = \sqrt{c/0.3}$ and the y -axis at $y = \sqrt{c/0.7}$. Thus the x -intercept is larger than the y -intercept. A similar argument tells us that the x -intercept of $j(x, y) = 0.7x^2 + 0.3y^2 = c$ is smaller than its y -intercept.

Thus Graph (I) is $h(x, y)$; Graph (II) is $j(x, y)$; Graph (III) is $f(x, y)$; Graph (IV) is $g(x, y)$.

37. (a) Multiply the values on each contour of the original contour diagram by 3. See Figure 12.101.

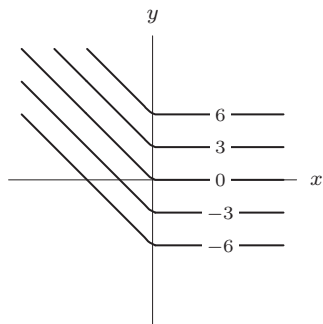

Figure 12.101: $3f(x, y)$

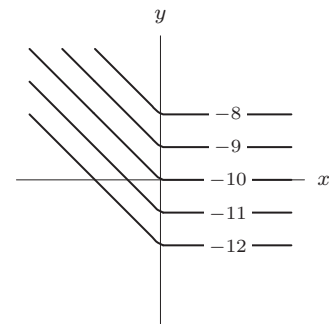

Figure 12.102: $f(x, y) - 10$

(b) Subtract 10 from the values on each contour. See Figure 12.102.

(c) Shift the diagram 2 units to the right and 2 units up. See Figure 12.103.

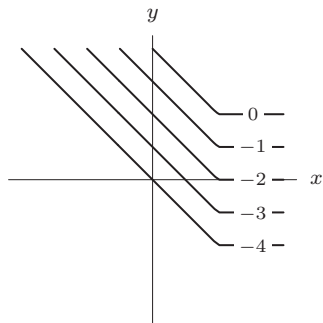

Figure 12.103: $f(x - 2, y - 2)$

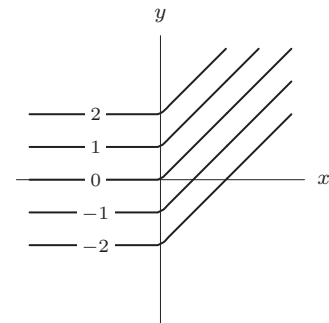

Figure 12.104: $f(-x, y)$

(d) Reflect the diagram about the y -axis. See Figure 12.104.

38. (a) See Figure 12.105.

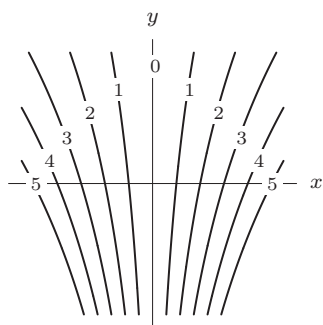

Figure 12.105

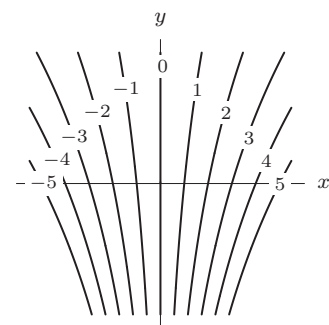

Figure 12.106

(b) See Figure 12.106.

39. Since $f(x, y) = x^2 - y^2 = (x - y)(x + y) = 0$ gives $x - y = 0$ or $x + y = 0$, the contours $f(x, y) = 0$ are the lines $y = x$ or $y = -x$. In the regions between them, $f(x, y) > 0$ or $f(x, y) < 0$ as shown in Figure 12.107. The surface $z = f(x, y)$ is above the xy -plane where $f > 0$ (that is on the shaded regions containing the x -axis) and is below the

xy -plane where $f < 0$. This means that a person could sit on the surface facing along the positive or negative x -axis, and with his/her legs hanging down the sides below the y -axis. Thus, the graph of the function is saddle-shaped at the origin.

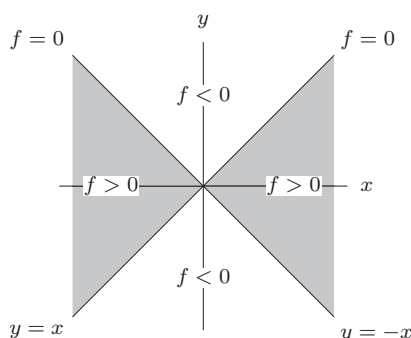

Figure 12.107

40. We need three lines with $g(x, y) = 0$, so that the xy -plane is divided into six regions. For example

$$g(x, y) = y(x - y)(x + y)$$

has the contour map in Figure 12.108. (Many other answers to this question are possible.)

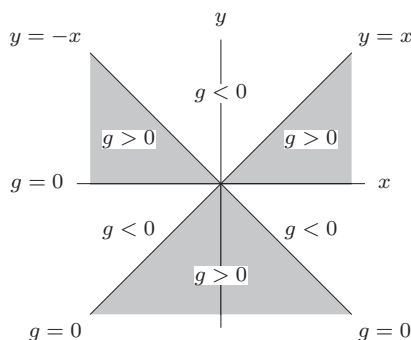

Figure 12.108

41. To read off the cross-sections of f with t fixed, we choose a t value and move horizontally across the diagram looking at the values on the contours. For $t = 0$, as we move from the left at $x = 0$ to the right at $x = \pi$, we cross contours of 0.25, 0.50, 0.75 and reach a maximum at $x = \pi/2$, and then decrease back to 0. That is because if time is fixed at $t = 0$, then $f(x, 0)$ is the displacement of the string at that time: no displacement at $x = 0$ and $x = \pi$ and greatest displacement at $x = \pi/2$. For cross-sections with t fixed at larger values, as we move along a horizontal line, we cross fewer contours and reach a smaller maximum value: the string is becoming less curved. At time $t = \pi/2$, the string is straight so we see a value of 0 all the way across the diagram, namely a contour with value 0. For $t = \pi$, the string has vibrated to the other side and the displacements are negative as we read across the diagram reaching a minimum at $x = \pi/2$.

The cross-sections of f with x fixed are read vertically. At $x = 0$ and $x = \pi$, we see vertical contours of value 0 because the end points of the string have 0 displacement no matter what time it is. The cross-section for $x = \pi/2$ is found by moving vertically up the diagram at $x = \pi/2$. As we expect, the contour values are largest at $t = 0$, zero at $t = \pi/2$, and a minimum at $t = \pi$.

Notice that the spacing of the contours is also important. For example, for the $t = 0$ cross-section, contours are most closely spaced at the end points at $x = 0$ and $x = \pi$ and most spread out at $x = \pi/2$. That is because the shape of the string at time $t = 0$ is a sine curve, which is steepest at the end points and relatively flat in the middle. Thus, the contour diagram shows the steepest terrain at the end points and flattest terrain in the middle.

42. (a) Since P is proportional to d^2 and to v^3 , a formula for P is $P(d, v) = kd^2v^3$, where k is the constant of proportionality.

- (b) Let d be the diameter of the original windmill, and let v_1 be the wind speed at which the windmill produces 100 kW. Then

$$kd^2v_1^3 = 100, \quad \text{and thus} \quad k = \frac{100}{d^2v_1^3}.$$

The second windmill has diameter $2d$ and we want to find a speed v_2 such that $k(2d)^2v_2^3 = 100$. We solve for v_2 :

$$v_2^3 = \frac{100}{k(2d)^2} = \frac{100}{100/(d^2v_1^3) \cdot 4d^2} = \frac{d^2v_1^3}{4d^2} = \frac{v_1^3}{4}$$

$$v_2 = \frac{v_1}{\sqrt[3]{4}}$$

So v_2 needs to be $1/\sqrt[3]{4}$ of v_1 , or about 63% of v_1 .

- (c) Contours of P are curves of the form $kd^2v^3 = c$, or $v = \sqrt[3]{c/(kd^2)}$. Thus, a contour diagram for P looks like the diagram in Figure 12.109.

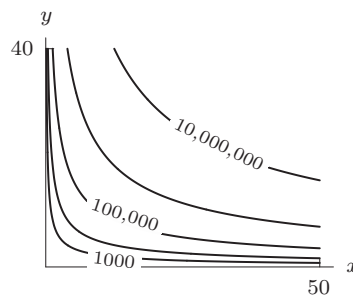

Figure 12.109

Strengthen Your Understanding

43. A contour diagram for $z = f(x, y)$ is a collection of curves in the xy -plane. The contour diagram is like a 2-dimensional map of the graph of $f(x, y)$, which is a surface in 3-space.
44. The contours of both functions are concentric circles centered at $(x, y) = (0, 0)$. However, for the equally spaced z -values, such as $z = 1, 2, 3, 4, \dots$, the contour diagram of f consists of equally spaced concentric circles, whereas the contour diagram of g consists of circles that get closer and closer together as z increases in value.
45. The function $f(x, y) = x^2$ has contours that are two parallel lines for positive values of z . In particular for $z = 10$, the contour of f consists of two parallel lines: $x = \pm\sqrt{10}$. The functions $g(x, y) = |y|$ and $h(x, y) = x^3 - 9x + 5$ also work. The $z = 10$ contour of h consists of three parallel lines. There are many others possibilities.
46. If $z = f(x, y) = y - x^2$, then all the contours have the form $y - x^2 = c$, so $y = x^2 + c$, which are parabolas for every value of c .
47. Could not be true. If the origin is on the level curve $z = 1$, then $z = f(0, 0) = 1 \neq -1$. So $(0, 0)$ cannot be on both $z = 1$ and $z = -1$.
48. Might be true. One may consider the function

$$z = f(x, y) = (x^2 + y^2 - 2)(x^2 + y^2 - 3) + 1$$

49. Might be true. The function $z = x^2 - y^2 + 1$ has this property. The level curve $z = 1$ is the lines $y = x$ and $y = -x$.
50. Not true. There are no level curves for $z > 1$ or $z \leq 0$.
51. True. For every point (x, y) , compute the value $z = e^{-(x^2+y^2)}$ at that point. The level curve obtained by getting z equal to that value goes through the point (x, y) .
52. True. If there were such an intersection point, that point would have two different temperatures simultaneously.
53. True. Different regions that are isolated from each other can have the same temperature.

54. True. If $f = c$ then the contours are of the form $c = y^2 + (x - 2)^2$, which are circles centered at $(2, 0)$ if $c > 0$. But if $c = 0$ the contour is the single point $(2, 0)$.
55. False. The graph could be a hemisphere, a bowl-shape, or any surface formed by rotating a curve about a vertical line.
56. False. Contours get closer together in a direction if the function is increasing or decreasing *at an increasing rate* in that direction.
57. False. As a counterexample, consider any function with one variable missing, e.g. $f(x, y) = x^2$. The graph of this is not a plane (it is a *parabolic cylinder*) but has contours which are lines of the form $x = c$.
58. False. The fact that the $f = 10$ and $g = 10$ contours are identical only says that one horizontal slice through each graph is the same, but does not imply that the entire graphs are the same. A counterexample is given by $f(x, y) = x^2 + y^2$ and $g(x, y) = 20 - x^2 - y^2$.
59. True. The graph of g is the same as the graph of f translated down by 5 units, so the horizontal slice of f at height 5 is the same as the horizontal slice of g at height 0.

Solutions for Section 12.4

Exercises

1.

Table 12.14

$x \backslash y$	0.0	1.0
0.0	-1.0	1.0
2.0	3.0	5.0

2.

Table 12.15

$x \backslash y$	-1.0	0.0	1.0
2.0	4.0	6.0	8.0
3.0	1.0	3.0	5.0

3. A table of values is linear if the rows are all linear and have the same slope and the columns are all linear and have the same slope. The table does not represent a linear function since none of the rows or columns is linear.
4. A table of values is linear if the rows are all linear and have the same slope and the columns are all linear and have the same slope. We see that the table might represent a linear function since the slope in each row is 3 and the slope in each column is -4 .
5. A table of values is linear if the rows are all linear and have the same slope and the columns are all linear and have the same slope. The table might represent a linear function since the slope in each row is 5 and the slope in each column is 2.
6. A table of values is linear if the rows are all linear and have the same slope and the columns are all linear and have the same slope. The table does not represent a linear function since different rows have different slopes.
7. A contour diagram is linear if the contours are parallel straight lines, equally spaced for equally spaced values of z . This contour diagram could represent a linear function.
8. A contour diagram is linear if the contours are parallel straight lines, equally spaced for equally spaced values of z . We see that the contour diagram in the problem does not represent a linear function.
9. Since

$$\begin{aligned} 0 &= c + m \cdot 0 + n \cdot 0 & c &= 0 \\ -1 &= c + m \cdot 0 + n \cdot 2 & c + 2n &= -1 \\ -4 &= c + m \cdot (-3) + n \cdot 0 & c - 3m &= -4 \end{aligned}$$

we get:

$$c = 0, m = \frac{4}{3}, n = -\frac{1}{2}.$$

$$\text{Thus, } z = \frac{4}{3}x - \frac{1}{2}y.$$

10. Let the equation of the plane be

$$z = c + mx + ny$$

Since we know the points: $(4, 0, 0)$, $(0, 3, 0)$, and $(0, 0, 2)$ are all on the plane, we know that they satisfy the same equation. We can use these values of (x, y, z) to find c , m , and n . Putting these points into the equation we get:

$$0 = c + m \cdot 4 + n \cdot 0 \quad \text{so } c = -4m$$

$$0 = c + m \cdot 0 + n \cdot 3 \quad \text{so } c = -3n$$

$$2 = c + m \cdot 0 + n \cdot 0 \quad \text{so } c = 2$$

Because we have a value for c , we can solve for m and n to get

$$c = 2, m = -\frac{1}{2}, n = -\frac{2}{3}.$$

So the linear function is

$$z = 2 - \frac{1}{2}x - \frac{2}{3}y.$$

11. Figure 12.110 shows the two lines the plane must contain.

Both lines are parallel to the x -axis; thus our plane must have x -slope zero. On the other hand, the line in the xy -plane is 2 units down and one unit to the right of the line in the xz -plane; hence the y -slope of our plane must be -2 . Thus the equation is

$$z = 0x - 2y + c = -2y + c,$$

for some constant c . Since the plane contains the point $(0, 0, 2)$, the value of c must be 2. So the equation is

$$z = -2y + 2.$$

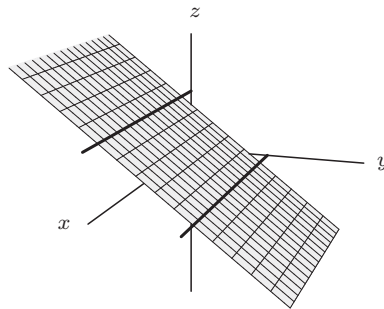

Figure 12.110

12. When $y = 0$, $c + mx = 3x + 4$, so $c = 4$, $m = 3$. Thus, when $x = 0$, we have $4 + ny = y + 4$, so $n = 1$. Thus, $z = 4 + 3x + y$.
13. (a) Since z is a linear function of x and y with slope 2 in the x -direction, and slope 3 in the y -direction, we have:

$$z = 2x + 3y + c$$

We can write an equation for changes in z in terms of changes in x and y :

$$\begin{aligned} \Delta z &= (2(x + \Delta x) + 3(y + \Delta y) + c) - (2x + 3y + c) \\ &= 2\Delta x + 3\Delta y \end{aligned}$$

Since $\Delta x = 0.5$ and $\Delta y = -0.2$, we have

$$\Delta z = 2(0.5) + 3(-0.2) = 0.4$$

So a 0.5 change in x and a -0.2 change in y produces a 0.4 change in z .

- (b) As we know that $z = 2$ when $x = 5$ and $y = 7$, the value of z when $x = 4.9$ and $y = 7.2$ will be

$$z = 2 + \Delta z = 2 + 2\Delta x + 3\Delta y$$

where Δz is the change in z when x changes from 4.9 to 5 and y changes from 7.2 to 7. We have $\Delta x = 4.9 - 5 = -0.1$ and $\Delta y = 7.2 - 7 = 0.2$. Therefore, when $x = 4.9$ and $y = 7.2$, we have

$$z = 2 + 2 \cdot (-0.1) + 3 \cdot 0.2 = 2.4$$

14. (a) Substituting in the values for the slopes, we see that the formula for the plane is $z = c + 5x - 3y$ for some value of c . Substituting the point $(4, 3, -2)$ gives $c = -13$. The formula for the plane is

$$z = -13 + 5x - 3y.$$

- (b) When $z = 0$, we have

$$0 = -13 + 5x - 3y$$

$$3y = 5x - 13$$

$$y = \frac{5}{3}x - \frac{13}{3}.$$

The contour for $z = 0$ is a line with slope $5/3$ and y -intercept $13/3$. Similarly we find other contours. See Figure 12.111.

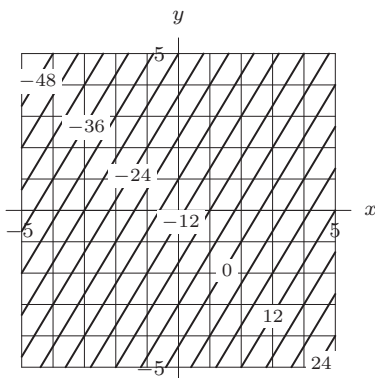

Figure 12.111

Problems

15. The revenue function, R , is linear and so we may write it as:

$$R = (p_1)c + (p_2)d$$

where p_1 is the price of CDs and p_2 is the price of DVDs, in dollars. From the diagram, we can pick two points, such as $c = 100, d = 100$ on the contour $R = 2000$, and $c = 50, d = 300$ on the contour $R = 4000$. These points give the following system of linear equations:

$$2000 = 100p_1 + 100p_2$$

$$4000 = 50p_1 + 300p_2.$$

Solving gives $p_1 = 8$ dollars and $p_2 = 12$ dollars.

16. (a) Yes.
 (b) The coefficient of m is 15 dollars per month. It represents the monthly charge to use this service. The coefficient of t is 0.05 dollars per minute. Each minute the customer is on-line costs 5 cents.
 (c) The intercept represents the base charge. It costs \$35 just to get hooked up to this service.
 (d) We have $f(3, 800) = 120$. A customer who uses this service for three months and is on-line for a total of 800 minutes is charged \$120.

17. (a) Expenditure, E , is given by the equation:

$$E = (\text{price of raw material 1})m_1 + (\text{price of raw material 2})m_2 + C$$

where C denotes all the other expenses (assumed to be constant). Since the prices of the raw materials are constant, but m_1 and m_2 are variables, we have a linear function.

- (b) Revenue, R , is given by the equation:

$$R = (p_1)q_1 + (p_2)q_2.$$

Since p_1 and p_2 are constant, while q_1 and q_2 are variables, we again have a linear function.

- (c) Revenue is again given by the equation,

$$R = (p_1)q_1 + (p_2)q_2.$$

Since p_2 and q_2 are now constant, the term $(p_2)q_2$ is also constant. However, since p_1 and q_1 are variables, the $(p_1)q_1$ term means that the function is not linear.

18. The data in Table 12.10 is apparently linear with a slope in the w direction of about 0.9 calories burned for every extra 20 lbs of weight, and a slope in the s direction of about 1.6 calories burned for every extra mile per hour of speed. Since $B = 4.2$ when $w = 120$ and $s = 8$, a formula for B is

$$B = 4.2 + 0.9(w - 120) + 1.6(s - 8).$$

The formula does not make sense for low weights or speeds. For example, it says that a person weighing 120 pounds going 5 mph burns a negative number of calories per minute, as would a person (child) weighing 60 lbs and going 7 mph.

19. The time in minutes to go 10 miles at a speed of s mph is $(10/s)(60) = 600/s$. Thus the 120 lb person going 10 mph uses $(7.4)(600/10) = 444$ calories, and the 180 lb person going 8 mph uses $(7.0)(600/8) = 525$ calories. The 120 lb person burns $444/120 = 3.7$ calories per pound for the trip, while the 180 lb person burns $525/180 = 2.9$ calories per pound for the trip.
20. A trip of 10 miles at s mph takes $10/s$ hours = $600/s$ minutes. Since the number of calories burned per minute is B , the total number of calories burned on the trip is $B \cdot 600/s$. Thus

$$P = \frac{B(600/s)}{w} = \frac{600(4.2 + 0.9(w - 120) + 1.6(s - 8))}{sw}$$

21. The function, g , has a slope of 3 in the x direction and a slope of 1 in the y direction, so $g(x, y) = c + 3x + y$. Since $g(0, 0) = 0$, the formula is $g(x, y) = 3x + y$.
22. The function h decreases as y increases: each increase of y by 2 takes you down one contour and hence changes the function by 2, so the slope in the y direction is -1 . The slope in the x direction is 2, so the formula is $h(x, y) = c + 2x - y$. From the diagram we see that $h(0, 0) = 4$, so $c = 4$. Therefore, the formula for this linear function is $h(x, y) = 4 + 2x - y$.
23. For each column in the table, we find that as x increases by 1, $f(x, y)$ increases by 2, so the x slope is 2. For each row in the table, we find that as y increases by 1, $f(x, y)$ decreases by 0.5, so the y slope is -0.5 . So the function has the form $f(x, y) = 2x - 0.5y + c$. Also note that $f(0, 0) = 1$, so $c = 1$. Therefore, the function is $f(x, y) = 2x - 0.5y + 1$.
24. For each column in the table, we find that as x increases by 100, $f(x, y)$ decreases by 1, so the x slope is -0.01 . For each row in the table, we find that as y increases by 10, $f(x, y)$ increases by 3, so the y slope is 0.3. So the function has the form $f(x, y) = -0.01x + 0.3y + c$. Also note that $f(100, 10) = 3$, so $c = 1$. Therefore, the function is $f(x, y) = -0.01x + 0.3y + 1$.
25. See Figure 12.112.

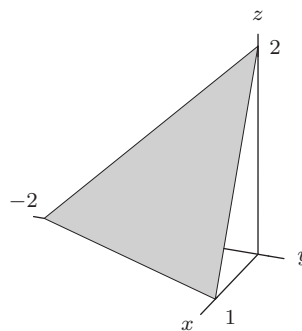

Figure 12.112

26. See Figure 12.113.

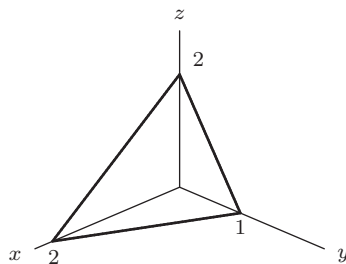

Figure 12.113

27. See Figure 12.114.

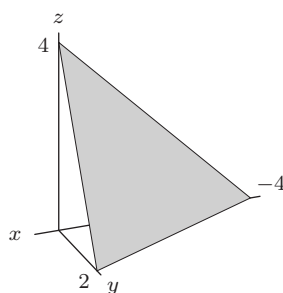

Figure 12.114

28. See Figure 12.115.

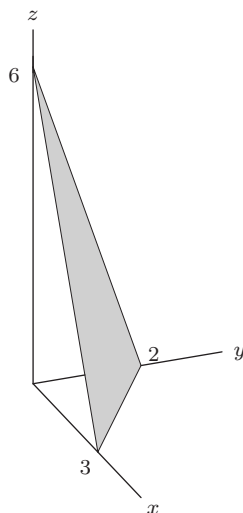

Figure 12.115

29. (a) The contours of f have equation

$$k = c + mx + ny, \quad \text{where } k \text{ is a constant.}$$

Solving for y gives:

$$y = -\frac{m}{n}x + \frac{k - c}{n}$$

Since c , m , n and k are constants, this is the equation of a line. The coefficient of x is the slope and is equal to $-m/n$.

- (b) Substituting $x + n$ for x and $y - m$ for y into $f(x, y)$ gives

$$f(x + n, y - m) = c + m(x + n) + n(y - m)$$

Multiplying out and simplifying gives

$$f(x + n, y - m) = c + mx + mn + ny - nm$$

$$f(x + n, y - m) = c + mx + ny = f(x, y)$$

- (c) Part (b) tells us that if we move n units in the x direction and $-m$ units in the y direction, the value of the function $f(x, y)$ remains constant. Since contours are lines where the function has a constant value, this implies that we remain on the same contour. This agrees with part (a) which tells us that the slope of any contour line will be $-m/n$. Since the slope is $\Delta y/\Delta x$, it follows that changing y by $-m$ and x by n will keep us on the same contour.
30. (a) We see always the same change in z , namely $\Delta z = 7$, for each step through the table in this diagonal direction. For example, in the third step of the diagonal starting at 3 we get $24 - 17 = 7$, and in the second step of the diagonal starting at 6 we get $20 - 13 = 7$.
- (b) We see always the same change in z , namely $\Delta z = -5$, for each step in this direction. For example, in the second step starting from 19 we get $9 - 14 = -5$, and in the first step starting at 22 we get $17 - 22 = -5$.
- (c) For a linear function, $z = mx + ny + c$, we have:

$$z_1 - z_2 = (mx_1 + ny_1 + c) - (mx_2 + ny_2 + c) = m(x_1 - x_2) + n(y_1 - y_2).$$

Writing $\Delta z = z_1 - z_2$, and $\Delta x = x_1 - x_2$, and $\Delta y = y_1 - y_2$, we have

$$\Delta z = m\Delta x + n\Delta y.$$

For the particular linear function in this problem, we have

$$\Delta z = \frac{4}{5}\Delta x + \frac{3}{2}\Delta y.$$

In part (a), as we move down the diagonal, we are taking steps with the same $\Delta x = 5$ and same $\Delta y = 2$. Therefore we will get the same change in z for each step,

$$\Delta z = \frac{4}{5}(5) + \frac{3}{2}(2) = 7.$$

In part (b), for each step we have $\Delta x = -10$ and $\Delta y = 2$, so for each step

$$\Delta z = \frac{4}{5}(-10) + \frac{3}{2}(2) = -5.$$

31. (a) We have $\Delta z = 7$. Thus

$$\text{Slope} = \frac{7}{\sqrt{5^2 + 2^2}} = \frac{7}{\sqrt{29}}.$$

- (b) We have $\Delta z = -5$. Thus

$$\text{Slope} = \frac{-5}{\sqrt{(-10)^2 + 2^2}} = \frac{-5}{\sqrt{104}}.$$

32. Graph (I) has contour lines that slope upward from left to right, so it corresponds to h, j, k , or m . Since the values on the contour lines are increasing with x and decreasing with y , Graph (I) corresponds to h or j . Since $(0, 0, 12)$ is a point on the contours of h but not of j for $-2 \leq x, y \leq 2$, the values on the contour lines show that Graph (I) corresponds to h .

Graph (II) has contour lines that slope downward from left to right, so it corresponds to f, g, n , or p . Since the values on the contour lines are decreasing with x and with y , Graph (II) corresponds to n or p . Since $(0, 0, 14)$ is a point on the contours of n but not of p for $-2 \leq x, y \leq 2$, the values on the contour lines show that Graph (II) corresponds to n .

Graph (III) has contour lines that slope downward from left to right, so it corresponds to f, g, n , or p . Since the values on the contour lines are increasing with x and with y , Graph (III) corresponds to f or g . Since $(0, 0, 10)$ is a point on the contours of f but not of g for $-2 \leq x, y \leq 2$, the values on the contour lines show that Graph (III) corresponds to f .

Graph (IV) has contour lines that slope upward from left to right, so it corresponds to h, j, k , or m . Since the values on the contour lines are increasing with y and decreasing with x , Graph (IV) corresponds to k or m . Since $(0, 0, 60)$ is a point on the contours of m but not of k for $-2 \leq x, y \leq 2$, the values on the contour lines show that Graph (IV) corresponds to m .

Strengthen Your Understanding

33. The function $f(x, y) = e^{x+y}$ has contours that are parallel lines $x + y = c$, but it is not linear. This example generalizes to $g(x + y)$ for any function $g(t)$. The family of functions $h(x, y) = r(x)$ also works, for any function r . There are other examples.
34. The function $f(x, y) = xy$ has linear cross-sections for both x and y fixed, but it is not linear. Any function of the form $g(x, y) = (mx + b)(ny + c)$ also satisfies this condition.
35. A possible example is in Table 12.16, where the rows have slopes 1, 2, 3, respectively, and the columns have slopes 1, 2, 3. Notice that the function is not linear since the slopes in each row (and in each column) are different.

Table 12.16

$x \backslash y$	1	2	3
1	1	2	3
2	2	4	6
3	3	6	9

36. If the linear function is $z = mx + ny + c$, then the contour for $z = 0$ is:

$$mx + ny + c = 0.$$

We want this line to have slope 2, so we rewrite it in slope-intercept form:

$$y = -\frac{m}{n}x - \frac{c}{n}.$$

Thus, we want $-m/n = 2$, for example $m = -2, n = 1$. So $z = -2x + y$ is one example. There are others.

37. False. At every point (x, y) the z coordinate on the first plane is 2 units lower than the second so these planes are parallel and do not intersect.
38. False. The first row is linear with slope $1/0.1 = 10$. The second row is linear with slope $1.07/0.1 = 10.7$. Since the slope of the first row is not the same as the slope of the second row, the function is not linear.
39. False. The contours are of the form $c = 3x + 2y$ which are lines with slope $-3/2$.
40. True. The contours of a linear function $f(x, y) = c + mx + ny$ look like $k = c + mx + ny$ which are parallel lines with slope $-m/n$.
41. True. $f(0, 0) = 0, f(0, 1) = 4$ give a y slope of 4, but $f(0, 0) = 0, f(0, 3) = 5$ give a y slope of $5/3$. Since linearity means the y slope must be the same between any two points, this function cannot be linear.
42. True. A linear function has constant slopes in the x and y directions, so its graph is a plane.
43. True. Since the graph of a linear function is a plane, any vertical slice parallel to the yz -plane will yield a line.
44. False. Any function of the form $f(x, y) = c$ is linear (with zero slope in both the x and y directions) and has a graph which is parallel to the xy -plane.
45. True. Functions can have only one value for a given input, so their graphs can intersect a vertical line at most once. A vertical plane would not satisfy this property, so cannot be the graph of a function.
46. False. There is at least one point where $f(a, b) = 0$, for example $(a, b) = (1, 1)$. There are an infinite number of other points lying on the straight-line contour $f(a, b) = 0$.
47. False. All of the columns have to have the same slope, as do the rows, but the row slopes can differ from the column slopes.
48. False. Simply knowing where the plane intersects the xy -plane does not determine the plane uniquely. There are an infinite number of linear functions whose graph intersects the xy -plane in this line. Two examples: $f(x, y) = -1 - 2x + y$ and $g(x, y) = -2 - 4x + 2y$.

Solutions for Section 12.5

Exercises

- (a) Observe that setting $f(x, y, z) = c$ gives a cylinder about the x -axis, with radius \sqrt{c} . These surfaces are in graph (I).
 (b) By the same reasoning the level curves for $h(x, y, z)$ are cylinders about the y -axis, so they are represented in graph (II).
- Points on one of the nested spheres in II have constant distance from the origin, so these spheres are level surfaces $f(x, y, z) = x^2 + y^2 + z^2 = c$. Points on one of the nested cylinders in I have constant distance from the y -axis, so these cylinders are level surfaces $g(x, y, z) = x^2 + z^2 = k$.
- If we solve for z , we get $z = \frac{1}{3}(5 - x - 2y)$, so the level surface is the graph of $f(x, y) = \frac{1}{3}(5 - x - 2y)$.
- We are looking for all points (x, y, z) whose distance from the origin is 2, that is, $(x - 0)^2 + (y - 0)^2 + (z - 0)^2 = 4$, or $x^2 + y^2 + z^2 = 4$, which is a level surface of $f(x, y, z) = x^2 + y^2 + z^2$.
- If we solve for z , we get $z = (1 - x^2 - y^2)^2$, so the level surface is the graph of $f(x, y) = (1 - x^2 - y^2)^2$.
- We are looking for all points (x, y, z) whose distance from (a, b, c) is a constant k , that is, $(x - a)^2 + (y - b)^2 + (z - c)^2 = k^2$, which is a level surface of $f(x, y, z) = (x - a)^2 + (y - b)^2 + (z - c)^2$.
- Only the elliptical paraboloid, the hyperbolic paraboloid and the plane. These are the only surfaces in the catalog that satisfy the “vertical line test,” that is, they have at most one z -value for each x and y .
- An elliptic paraboloid.
- A hyperboloid of two sheets.
- A plane.
- An ellipsoid.
- Yes,

$$z = f(x, y) = x^2 + 3y^2.$$

- Yes,

$$z = f(x, y) = \frac{2}{5}x + \frac{3}{5}y - 2.$$

- No, because some z values correspond to two points on the surface.

- No, because $z = \sqrt{x^2 + 3y^2}$ and $z = -\sqrt{x^2 + 3y^2}$, so some z -values correspond to two points on the surface.

Problems

- The plane is represented by

$$z = f(x, y) = 2x - \frac{y}{2} - 3$$

and

$$g(x, y, z) = 4x - y - 2z = 6.$$

Other answers are possible

- The top half of the sphere is represented by

$$z = f(x, y) = \sqrt{10 - x^2 - y^2}$$

and

$$g(x, y, z) = x^2 + y^2 + z^2 = 10, \quad z \geq 0.$$

Other answers are possible.

- The bottom half of the ellipsoid is represented by

$$z = f(x, y) = -\sqrt{2(1 - x^2 - y^2)}$$

$$g(x, y, z) = x^2 + y^2 + \frac{z^2}{2} = 1, \quad z \leq 0.$$

Other answers are possible

19. (a) The isothermal surfaces of f are parallel planes. Each plane is described by the equation

$$2x - 3y + z = c + 20,$$

for each value of the constant c .

- (b) We have:

$$f_z(0, 0, 0) = 1.$$

This means that if we start at the point $(0, 0, 0)$ and move slightly upwards in the direction of the positive z -axis, our temperature is increasing by one degree Fahrenheit for each additional unit we move.

- (c) To increase our temperature the fastest we should move away from the isothermal plane passing through $(0, 0, 0)$ in a direction that allows us to reach the warmer isothermal planes as fast as possible. This means that we should follow a normal vector to the isothermal plane passing through $(0, 0, 0)$ that has a positive \vec{k} component (temperature increases with c and $c + 20$ gives the z -intercept of each isothermal plane). We have:

$$\text{Isothermal plane through } (0, 0, 0) : 2x - 3y + z = 20,$$

$$\text{Normal vector to isothermal plane through } (0, 0, 0) : \vec{n} = 2\vec{i} - 3\vec{j} + \vec{k}.$$

So, we must move away from the origin in the direction of the vector $2\vec{i} - 3\vec{j} + \vec{k}$.

- (d) Isothermal surfaces of f are of the form

$$z = c + 20 - 2x + 3y,$$

so, setting $c = -3$, we see that $f(x, y) = -2x + 3y + 17$ is an isothermal surface of f . On this surface the temperature is -3 degrees Fahrenheit.

20. (a) We expect B to be an increasing function of all three variables.
 (b) A deposit of \$1250 at a 1% annual interest rate leads to a balance of \$1276 after 25 months.
21. We expect P to be an increasing function of A and r . (If you borrow more, your payments go up; if the interest rates go up, your payments go up.) However, P is a decreasing function of t . (If you spread out your payments over more years, you pay less each month.)
22. The graph of $g(x, y) = x + 2y$ is the set of all points (x, y, z) satisfying $z = x + 2y$, or $x + 2y - z = 0$. This is a level surface, but we want the surface equal to the constant value 1, not 0, so we can add 1 to both sides to get $x + 2y - z + 1 = 1$. Thus, $f(x, y, z) = x + 2y - z + 1$ has level surface $f = 1$ identical to the graph of $g(x, y) = x + 2y$.
23. If we solve $x^2 + y^2/4 + z^2/9 = 1$ for z we get $z = \pm 3\sqrt{1 - x^2 - y^2/4}$. Thus we can take $f(x, y) = 3\sqrt{1 - x^2 - y^2/4}$ and $g(x, y) = -3\sqrt{1 - x^2 - y^2/4}$.
24. The equation of any plane parallel to the plane $z = 2x + 3y - 5$ has x -slope 2 and y -slope 3, so has equation $z = 2x + 3y - c$ for any constant c , or $2x + 3y - z = c$. Thus we could take $g(x, y, z) = 2x + 3y - z$. Other answers are possible.
25. (a) The graph of $f(x, y)$ is obtained by plotting points (x, y, z) , where $z = f(x, y)$. Since the square root function is never negative, we have $z \geq 0$. Setting $z = \sqrt{1 - x^2 - y^2}$ and squaring both sides leads to $x^2 + y^2 + z^2 = 1$, which is the equation for a sphere of radius 1. The graph of the function includes only those points where $z \geq 0$, that is, the upper hemisphere of radius 1, centered at the origin.
 (b) If we take $g(x, y, z) = f(x, y) - z = \sqrt{1 - x^2 - y^2} - z$, then the level surface $g(x, y, z) = 0$ is the surface S .
26. (a) The graph of $f(x, y)$ is obtained by plotting points (x, y, z) , where $z = f(x, y)$. Since the square root function is never negative, we have $z \geq 0$. Setting $z = \sqrt{1 - y^2}$ and squaring both sides leads to $y^2 + z^2 = 1$, which is the equation for a circular cylinder of radius 1 lying along the x -axis (since x is missing from the equation). The graph of the function includes only those points where $z \geq 0$, that is, the upper half of the cylinder.
 (b) If we take $g(x, y, z) = f(x, y) - z = \sqrt{1 - y^2} - z$, then the level surface $g(x, y, z) = 0$ is the surface S .
27. Starting with the equation $z = \sqrt{x^2 + y^2}$, we flip the cone and shift it up one, yielding $z = 1 - \sqrt{x^2 + y^2}$. This is a cone with vertex at $(0, 0, 1)$ that intersects the xy -plane in a circle of radius 1. Interchanging the variables, we see that $y = 1 - \sqrt{x^2 + z^2}$ is an equation whose graph includes the desired cone C . Finally, we express this equation as a level surface $g(x, y, z) = 1 - \sqrt{x^2 + z^2} - y = 0$.
28. In the xz -plane, the equation $x^2/4 + z^2 = 1$ is an ellipse, with widest points at $x = \pm 2$ on the x -axis and crossing the z -axis at $z = \pm 1$. Since the equation has no y term, the level surface is a cylinder of elliptical cross-section, centered along the y -axis.
29. Setting y to a constant c yields the equation $x^2 + z^2 = 1 - c^2/4$, which, for $-2 \leq c \leq 2$ gives circular cross-sections. Fixing $x = c$ yields the equation $y^2/4 + z^2 = 1 - c^2$, which for $-1 \leq c \leq 1$ yields elliptical cross-sections. A similar result is true for cross-sections with constant z . Thus the level surface appears to be a unit sphere, centered at the origin, that has been stretched by a factor of two in the y -direction (this shape is called an ellipsoid).

30. The level surfaces are graphs of the equations $x + y + z = c$ for different values of the constant c . These are all parallel planes.
31. The level surfaces are the graphs of $\sin(x + y + z) = k$ for constant k (with $-1 \leq k \leq 1$). This means $x + y + z = \sin^{-1}(k) + 2\pi n$, or $\pi - \sin^{-1}(k) + 2\pi n$ for all integers n . Therefore for each value of k , with $-1 \leq k \leq 1$, we get an infinite family of parallel planes. So the level surfaces are families of parallel planes.
32. Let's consider the function $y = 2 + \sin z$ drawn in the yz -plane in Figure 12.116.

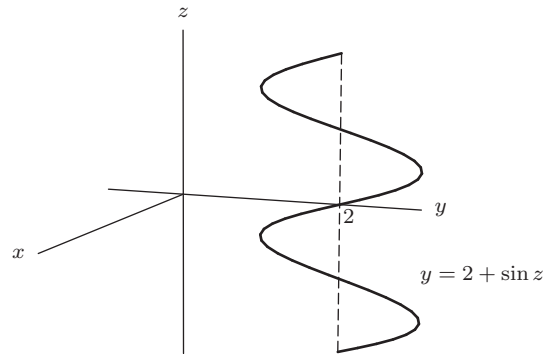

Figure 12.116

Now rotate this graph around the z -axis. Then, a point (x, y, z) is on the surface if and only if $x^2 + y^2 = (2 + \sin z)^2$. Thus, the surface generated is a surface of rotation with the profile shown in Figure 12.116.

Similarly, the surface with equation $x^2 + y^2 = (f(z))^2$ is the surface obtained rotating the graph of $y = f(z)$ around the z -axis.

33. $f(x, y, z) = x^2 - y^2 + z^2$ has 3 types of level surfaces depending on the values of c in the equation $x^2 - y^2 + z^2 = c$. We write this as $x^2 + z^2 = y^2 + c$ and think of what happens as we take a cross-section of the surface, perpendicular to the y -axis by holding y fixed.
- (i) For $c > 0$, the level surface is a hyperboloid of 1 sheet.
 - (ii) For $c < 0$, the level surface is a hyperboloid of 2 sheets.
 - (iii) For $c = 0$, the level surface is a cone.
34. The level surfaces are the graphs of $g(x, y, z) = e^{-(x^2 + y^2 + z^2)} = k$ for constant values of k such that $0 < k \leq 1$. So $x^2 + y^2 + z^2 = -\ln k$, which is the graph of a sphere since $-\ln k \geq 0$.
35. The level surfaces are all planes described as follows:

When $h(x, y, z) = 1$, the plane is given by

$$e^{z-y} = 1, \quad \text{so} \quad z - y = \ln 1 = 0.$$

When $h(x, y, z) = e$, the plane is given by

$$e^{z-y} = e, \quad \text{so} \quad z - y = \ln e = 1.$$

When $h(x, y, z) = e^2$, the plane is given by

$$e^{z-y} = e^2, \quad \text{so} \quad z - y = \ln e^2 = 2.$$

See Figure 12.117.

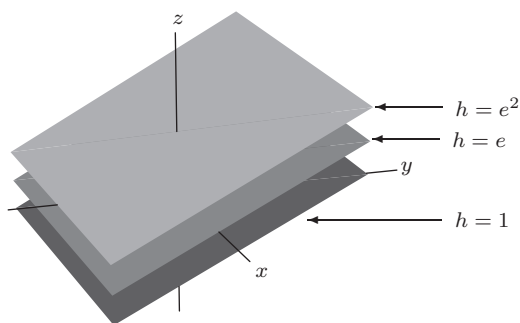

Figure 12.117

36. For values of $f < 4$, the level surfaces are spheres, with larger f giving smaller radii. See Figure 12.118.

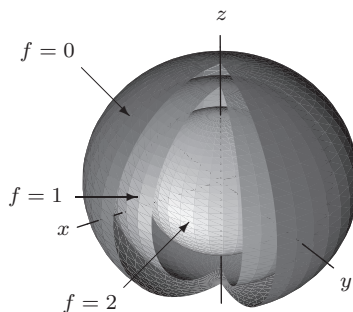

Figure 12.118

37. For values of $g < 1$, the level surfaces are cylinders centered on the z -axis, with larger g values giving smaller radii. See Figure 12.119.

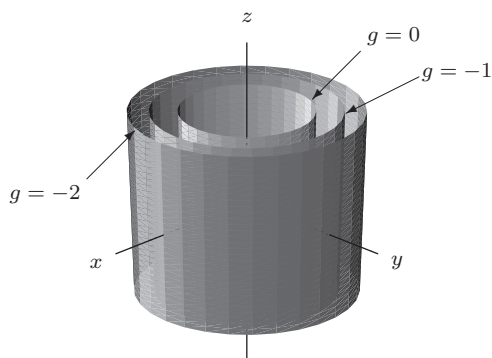

Figure 12.119

Strengthen Your Understanding

- 38. The graph of $f(x, y, z)$ is all points (x, y, z, w) in 4-space such that $w = f(x, y, z)$. This graph cannot be drawn in 3-space; it would need 4 dimensions.
- 39. Since z is missing in the formula for $f(x, y, z)$, the level surface $f(x, y, z) = x^2 - y^2 = c$ is a hyperbolic cylinder. All its cross-sections perpendicular to the z -axis are the same hyperbola $x^2 - y^2 = c$.

40. Since z is missing in the formula for $f(x, y, z)$, the level surface $f(x, y, z) = x^2 + y^2 = c$ is a cylinder running along the z -axis.
41. A linear function of three variables has level surfaces that are equally spaced planes. Choosing a linear function that does not depend on x gives level surfaces perpendicular to the yz -plane. The function $f(x, y, z) = y + z$, for example, works. Its level surfaces are the planes: $c = y + z$, or $z = -y + c$.
42. A cylinder centered on the y -axis has equation $x^2 + z^2 = c$, so we take $f(x, y, z) = x^2 + z^2$. There are other possible answers.
43. Let $f(x, y, z) = (x + y + z)^2$. Then $f(x, y, z) = c \geq 0$ means $x + y + z = \sqrt{c}$, which for different c are parallel planes.
44. One family of paraboloids is given by equations of the form $z = x^2 + y^2 - c$, where c is a constant. Rearranging this equation, we obtain $x^2 + y^2 - z = c$. Therefore, the level sets of the function $f(x, y, z) = x^2 + y^2 - z$ are paraboloids.
45. True. Both are the set of all points (x, y, z) in 3-space satisfying $z = x^2 + y^2$.
46. False. The graph of $f(x, y) = \sqrt{1 - x^2 - y^2}$ is the upper unit hemisphere, while the graph of $g = 1$ is $x^2 + y^2 + z^2 = 1$, which is the entire unit sphere (both spheres with center at the origin).
47. True. The graph of $f(x, y)$ is the set of all points (x, y, z) satisfying $z = f(x, y)$. If we define the three-variable function g by $g(x, y, z) = f(x, y) - z$, then the level surface $g = 0$ is exactly the same as the graph of $f(x, y)$.
48. False. For example, the function $g(x, y, z) = x^2 + y^2 + z^2$ has level surface $g = 1$ which is a sphere of radius 1, centered at the origin. This surface cannot be the graph of any function $f(x, y)$, since a vertical line intersects it in more than one place.
49. True. The level surfaces are of the form $x + 2y + z = k$, or $z = k - x - 2y$. These are the graphs of the linear functions $f(x, y) = k - x - 2y$, each of which has x -slope of -1 and y -slope equal to -2 . Thus they form parallel planes.
50. False. The level surfaces are of the form $x^2 + y + z^2 = k$, or $y = k - x^2 - z^2$. These are paraboloids centered on the y -axis, not cylinders.
51. False. The level surface $g = 0$ of the function $g(x, y, z) = x^2 + y^2 + z^2$ consists of only the origin.
52. True. The level surfaces $g = k$ are of the form $ax + by + cz + d = k$, or

$$z = \frac{1}{c}(-ax - by + (k - d)).$$

Thus z is a linear function of x and y , whose graph is a plane.

53. False. For example, the function $g(x, y, z) = \sin(x + y + z)$ has level surfaces of the form $x + y + z = k$, where $k = \arcsin(c) + n\pi$, for $n = 0, \pm 1, \pm 2, \dots$. These surfaces are planes (for $-1 \leq c \leq 1$).
54. True. If there is a point (a, b, c) lying on both $g(x, y, z) = k_1$ and $g(x, y, z) = k_2$, then we must have $g(a, b, c) = k_1$ and $g(a, b, c) = k_2$. Since g is a function, it can only have a single value at a point, so $k_1 = k_2$.

Solutions for Section 12.6

Exercises

- No, $1/(x^2 + y^2)$ is not defined at the origin, so is not continuous at all points in the square $-1 \leq x \leq 1, -1 \leq y \leq 1$.
- The function $1/(x^2 + y^2)$ is continuous on the square $1 \leq x \leq 2, 1 \leq y \leq 2$. The functions x^2 and y^2 are continuous everywhere, and so is their sum. The constant function 1 is continuous, and thus so is the ratio $1/(x^2 + y^2)$, as long as $x^2 + y^2 \neq 0$. Since the only place $x^2 + y^2 = 0$ is at the origin, and the origin is not included in the square, the function is continuous in the square.
- The function $y/(x^2 + 2)$ is continuous on the disk $x^2 + y^2 \leq 1$. The functions $x^2 + 2$ and y are continuous everywhere, and so is their ratio, as long as the denominator is not 0. But $x^2 + 2$ is always at least 2, so the function is continuous on the disk (actually at all points in the plane).
- The function $e^{\sin x}/\cos y$ is continuous on the rectangle $-\frac{\pi}{2} \leq x \leq \frac{\pi}{2}, 0 \leq y \leq \frac{\pi}{4}$. The functions $\sin x$ and e^x are continuous everywhere, and so is their composition $e^{\sin x}$. Then the ratio $e^{\sin x}/\cos y$ is continuous as long as the denominator is not 0. But $\cos y$ is not 0 in the interval $0 \leq y \leq \frac{\pi}{4}$, so the function is continuous on the given rectangle.
- The function $\tan(\theta)$ is undefined when $\theta = \pi/2 \approx 1.57$. Since there are points in the square $-2 \leq x \leq 2, -2 \leq y \leq 2$ with $x \cdot y = \pi/2$ (e.g. $x = 1, y = \pi/2$) the function $\tan(xy)$ is not defined inside the square, hence not continuous.

6. The function $\sqrt{2x-y}$ is undefined when $2x-y < 0$. Since there are points in the disk $x^2 + y^2 \leq 4$ with $2x-y < 0$ (e.g. $x=0, y=1$) the function $\sqrt{2x-y}$ is not defined at all points inside the disk and hence is not continuous.
7. Since the composition of continuous functions is continuous, the function f is continuous at $(0,0)$ and we have

$$\lim_{(x,y) \rightarrow (0,0)} f(x,y) = \lim_{(x,y) \rightarrow (0,0)} e^{-x-y} = e^{-0-0} = 1$$

8. Since the composition of continuous functions is continuous, the function f is continuous at $(0,0)$. We have:

$$\lim_{(x,y) \rightarrow (0,0)} f(x,y) = \lim_{(x,y) \rightarrow (0,0)} (x^2 + y^2) = 0 + 0 = 0.$$

9. Since f does not depend on y we have:

$$\lim_{(x,y) \rightarrow (0,0)} f(x,y) = \lim_{x \rightarrow 0} \frac{x}{x^2 + 1} = \frac{0}{0 + 1} = 0.$$

10. Since the composition of continuous functions is continuous, the function f is continuous at $(0,0)$. We have:

$$\lim_{(x,y) \rightarrow (0,0)} f(x,y) = \lim_{(x,y) \rightarrow (0,0)} \frac{x+y}{\sin y + 2} = \frac{0+0}{0+2} = 0.$$

11. We want to compute

$$\lim_{(x,y) \rightarrow (0,0)} f(x,y) = \lim_{(x,y) \rightarrow (0,0)} \frac{\sin(x^2 + y^2)}{x^2 + y^2}.$$

As $r = \sqrt{x^2 + y^2}$ is the distance from (x,y) to $(0,0)$ we have that $(x,y) \rightarrow (0,0)$ is equivalent to $r \rightarrow 0$. Hence the limit becomes:

$$\lim_{(x,y) \rightarrow (0,0)} f(x,y) = \lim_{r \rightarrow 0} \frac{\sin r^2}{r^2} = 1.$$

Problems

12. We want to show that f does not have a limit as (x,y) approaches $(0,0)$. So let us suppose that (x,y) tends to $(0,0)$ along the line $y = mx$, where the slope $m \neq 1$. Then

$$f(x,y) = f(x,mx) = \frac{x+mx}{x-mx} = \frac{(1+m)x}{(1-m)x} = \frac{1+m}{1-m}.$$

Therefore

$$\lim_{x \rightarrow 0} f(x,mx) = \frac{1+m}{1-m}$$

and so for $m = 2$ we get

$$\lim_{\substack{(x,y) \rightarrow (0,0) \\ y=2x}} f(x,y) = \frac{1+2}{1-2} = \frac{3}{-1} = -3$$

and for $m = 3$

$$\lim_{\substack{(x,y) \rightarrow (0,0) \\ y=3x}} f(x,y) = \frac{1+3}{1-3} = \frac{4}{-2} = -2.$$

Thus no matter how close they are to the origin, there will be points (x,y) where the value $f(x,y)$ is close to -3 and points (x,y) where $f(x,y)$ is close to -2 . So the limit:

$$\lim_{(x,y) \rightarrow (0,0)} f(x,y) \text{ does not exist.}$$

13. We want to show that f does not have a limit as (x, y) approaches $(0, 0)$. Let us suppose that (x, y) tends to $(0, 0)$ along the line $y = mx$. Then

$$f(x, y) = f(x, mx) = \frac{x^2 - m^2x^2}{x^2 + m^2x^2} = \frac{1 - m^2}{1 + m^2}.$$

Therefore

$$\lim_{x \rightarrow 0} f(x, mx) = \frac{1 - m^2}{1 + m^2}$$

and so for $m = 1$ we get

$$\lim_{\substack{(x, y) \rightarrow (0, 0) \\ y=x}} f(x, y) = \frac{1 - 1}{1 + 1} = \frac{0}{2} = 0$$

and for $m = 0$

$$\lim_{\substack{(x, y) \rightarrow (0, 0) \\ y=0}} f(x, y) = \frac{1 - 0}{1 + 0} = 1.$$

Thus no matter how close they are to the origin, there will be points (x, y) such that $f(x, y)$ is close to 0 and points (x, y) where $f(x, y)$ is close to 1. So the limit:

$$\lim_{(x, y) \rightarrow (0, 0)} f(x, y) \text{ does not exist.}$$

14. Points along the positive x -axis are of the form $(x, 0)$; at these points the function looks like $2x/2x = 1$ everywhere (except at the origin, where it is undefined). On the other hand, along the y -axis, the function looks like $-y^2/y^2 = -1$. Since approaching the origin along two different paths yields numbers that are not the same, the limit does not exist.
15. We want to show that f does not have a limit as (x, y) approaches $(0, 0)$. For this let us consider $x > 0, y > 0$, which gives

$$\lim_{\substack{(x, y) \rightarrow (0, 0) \\ x > 0, y > 0}} f(x, y) = \lim_{\substack{(x, y) \rightarrow (0, 0) \\ x > 0, y > 0}} \frac{xy}{|xy|} = 1.$$

On the other hand, if $x > 0, y < 0$, we get

$$\lim_{\substack{(x, y) \rightarrow (0, 0) \\ x > 0, y < 0}} f(x, y) = \lim_{\substack{(x, y) \rightarrow (0, 0) \\ x > 0, y < 0}} \frac{xy}{|xy|} = \lim_{\substack{(x, y) \rightarrow (0, 0) \\ x > 0, y < 0}} \frac{xy}{-xy} = -1.$$

Thus no matter how close to the origin they are, there will be points (x, y) such that $f(x, y)$ is close to 1 and points (x, y) such that $f(x, y)$ is close to -1 . So the limit

$$\lim_{(x, y) \rightarrow (0, 0)} f(x, y) \text{ does not exist.}$$

16. Let us suppose that (x, y) tends to $(0, 0)$ along the curve $y = kx^2$, where $k \neq -1$. We get

$$f(x, y) = f(x, kx^2) = \frac{x^2}{x^2 + kx^2} = \frac{1}{1 + k}.$$

Therefore:

$$\lim_{x \rightarrow 0} f(x, kx^2) = \frac{1}{1 + k}$$

and so for $k = 0$ we get

$$\lim_{\substack{(x, y) \rightarrow (0, 0) \\ y=0}} f(x, y) = 1$$

and for $k = 1$

$$\lim_{\substack{(x, y) \rightarrow (0, 0) \\ y=x^2}} f(x, y) = \frac{1}{2}.$$

Thus no matter how close they are to the origin, there will be points (x, y) where the value $f(x, y)$ is close to 1 and points (x, y) where $f(x, y)$ is close to $\frac{1}{2}$. So the limit:

$$\lim_{(x, y) \rightarrow (0, 0)} f(x, y)$$

does not exist.

17. For $x > 0$, we have

$$f(x, y) = y.$$

Thus, the surface representing f for $x > 0$ is the plane $z = y$.

For $x < 0$, we have

$$f(x, y) = -y.$$

Thus, the surface representing f for $x < 0$ is the plane $z = -y$.

For $x = 0$, we have

$$f(x, y) = 0.$$

Thus, the surface representing f is two half-planes and the y -axis.

- (a) The function is continuous at every point on the x -axis.
- (b) The function is not continuous at any point on the y -axis, except at the origin, because $f(x, y) = 0$ on the y -axis and not nearby unless $y = 0$.
- (c) The function is continuous at the origin.
- (a) Yes
- (b) No
- (c) Yes

18. The function, f is continuous at all points (x, y) with $x \neq 3$. We analyze the continuity of f at the point $(3, a)$. We have:

$$\lim_{\substack{(x,y) \rightarrow (3,a), \\ x < 3}} f(x, y) = \lim_{y \rightarrow a} (c + y) = c + a$$

$$\lim_{\substack{(x,y) \rightarrow (3,a), \\ x > 3}} f(x, y) = \lim_{x \rightarrow 3, x > 3} (5 - x) = 2.$$

We want to see if we can find one value of c such that $c + a = 2$ for all a . This would mean that $c = 2 - a$, but then c would be dependent on a . Therefore, we cannot make the function continuous everywhere.

19. The function f is continuous at all points (x, y) with $x \neq 3$. So let's analyze the continuity of f at the point $(3, a)$. We have

$$\lim_{\substack{(x,y) \rightarrow (3,a), \\ x < 3}} f(x, y) = \lim_{y \rightarrow a} (c + y) = c + a$$

$$\lim_{\substack{(x,y) \rightarrow (3,a), \\ x > 3}} f(x, y) = \lim_{y \rightarrow a} (5 - y) = 5 - a.$$

So we need to see if we can find one value for c such that $c + a = 5 - a$ for all a . This would require that $c = 5 - 2a$, but then c would depend on a , which is exactly what we don't want. Therefore, we cannot make the function continuous everywhere.

- 20. It is not continuous at $(0, 0)$. The function $f(x, y) = x^2 + y^2$ gets closer and closer to 0 as (x, y) gets closer to the origin; but the value of $f(0, 0)$ is not 0, it is 2. Since the value of the function is not equal to the limit, the function is not continuous at the origin.
- 21. The function $f(x, y) = x^2 + y^2 + 1$ gets closer and closer to 1 as (x, y) gets closer to the origin. To make f continuous at the origin, we need to have $f(0, 0) = 1$. Thus $c = 1$ will make the function continuous at the origin.
- 22. (a) The graphs are shown in Figure 12.120.

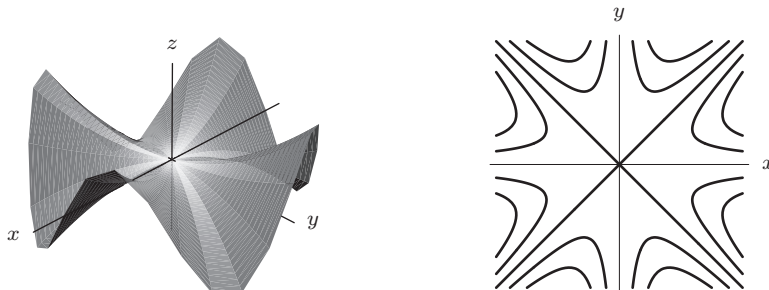

Figure 12.120

- (b) Yes, it seems that if x and y are both close to 0, the values of the function are both close to $0 = f(0, 0)$.

23. (a) We have $f(x, 0) = 0$ for all x and $f(0, y) = 0$ for all y , so these are both continuous (constant) functions of one variable.
- (b) The contour diagram suggests that the contours of f are lines through the origin. Providing it is not vertical, the equation of such a line is

$$y = mx.$$

To confirm that such lines are contours of f , we must show that f is constant along these lines. Substituting into the function, we get

$$f(x, y) = f(x, mx) = \frac{x(mx)}{x^2 + (mx)^2} = \frac{mx^2}{x^2 + m^2x^2} = \frac{m}{1 + m^2} = \text{constant}.$$

Since $f(x, y)$ is constant along the line $y = mx$, such lines are contained in contours of f .

- (c) We consider the limit of $f(x, y)$ as $(x, y) \rightarrow (0, 0)$ along the line $y = mx$. We can see that

$$\lim_{x \rightarrow 0} f(x, mx) = \frac{m}{1 + m^2}.$$

Therefore, if $m = 1$ we have

$$\lim_{\substack{(x, y) \rightarrow (0, 0) \\ y = x}} f(x, y) = \frac{1}{2}$$

whereas if $m = 0$ we have

$$\lim_{\substack{(x, y) \rightarrow (0, 0) \\ y = 0}} f(x, y) = 0.$$

Thus, no matter how close we are to the origin, we can find points (x, y) where the value $f(x, y)$ is $1/2$ and points (x, y) where the value $f(x, y)$ is 0 . So the limit $\lim_{(x, y) \rightarrow (0, 0)} f(x, y)$ does not exist. Thus, f is not continuous at $(0, 0)$, even though the one-variable functions $f(x, 0)$ and $f(0, y)$ are continuous at $(0, 0)$. See Figures 23 and 23

Strengthen Your Understanding

24. For continuity, one also needs the value of the limit to be the same as $f(a, b)$.
25. For the quotient f/g , one also needs $g(a, b) \neq 0$.
26. Let

$$f(x, y) = \frac{1}{x^2 + y^2} + \frac{1}{(x - 1)^2 + (y - 2)^2}.$$

27. Let

$$f(x, y) = \frac{x^2 + 2y^2}{x^2 + y^2}.$$

Approaching along the x -axis means setting $y = 0$, so then

$$f(x, y) = \frac{x^2}{x^2} = 1 \quad \text{for all } x \neq 0.$$

Thus, the limit approaching $(0, 0)$ along the x -axis is 1 .

Approaching along the y -axis means setting $x = 0$, so then

$$f(x, y) = \frac{2y^2}{y^2} = 2, \quad \text{for all } y \neq 0.$$

Thus, the limit approaching $(0, 0)$ along the y -axis is 2 .

28. One possible answer is $f(x, y) = \begin{cases} 0 & \text{if } x < 2 \\ 1 & \text{if } x \geq 2. \end{cases}$

29. One possible answer if $f(x, y) = 1/((x - 2)^2 + y^2)$.

30. One possible answer is $f(x, y) = 1/(x^2 + y^2 - 1)$.

Solutions for Chapter 12 Review

Exercises

- The distance of a point $P = (x, y, z)$ from the yz -plane is $|x|$, from the xz -plane is $|y|$, and from the xy -plane is $|z|$. So A is closest to the yz -plane, since it has the smallest x -coordinate in absolute value. B lies on the xz -plane, since its y -coordinate is 0. C is farthest from the xy -plane, since it has the largest z -coordinate in absolute value.
- Your final position is $(1, -1, -3)$. Therefore, you are in front of the yz -plane, to the left of the xz -plane, and below the xy -plane.
- An example is the line $z = -x$ in the xz -plane. See Figure 12.121.

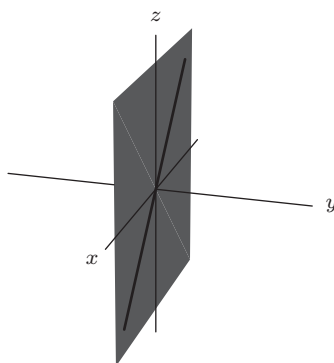

Figure 12.121

- Given (x, y) we can solve uniquely for z , namely $z = 5 - 3x + 2y$. Thus, z is a function of x and y :

$$z = f(x, y) = 5 - 3x + 2y.$$

- The equation $x^2 + y^2 + z^2 = 100$ does not determine z uniquely from x and y . For example, the points $(0, 0, 10)$ and $(0, 0, -10)$ both satisfy the equation. Therefore z is not a function of (x, y) .

- Given (x, y) we can solve uniquely for z , namely $z = 2 + \frac{x}{5} + \frac{y}{5} - \frac{3x^2}{5} + y^2$. Thus, z is a function of x and y :

$$z = f(x, y) = 2 + \frac{x}{5} + \frac{y}{5} - \frac{3x^2}{5} + y^2.$$

- Planes perpendicular to the positive y -axis should yield the graphs of upright parabolas $f(x, y)$, which widen as y decreases (giving $f(x, 2)$ and $f(x, 1)$). When $y = 0$, the parabola flattens out, creating a horizontal line for $f(x, 0)$. The graphs then turn downward, creating the parabolas $f(x, -1)$ and $f(x, -2)$ which become narrower as y decreases. So the graph (IV) bests fits this information.
- (a) is (IV). The level curves of f and g are lines, with slope of $f = -1$ and slope of $g = 1$. See Figure 12.122.
 (b) is (II). The level curves of f and g are lines, with slope of $f = -2/3$ and slope of $g = 2/3$. See Figure 12.123.
 (c) is (I). The level curves of f are parabolas opening upward; the level curves of g are the shape of $\ln x$, but upside down and for both positive and negative x -values. See Figure 12.124.
 (d) is (III). The level curves of f are hyperbolas centered on the x - or y -axes; the level curves of g are rectangular hyperbolas in quadrants (I) and (III) or quadrants (II) and (IV). See Figure 12.125.

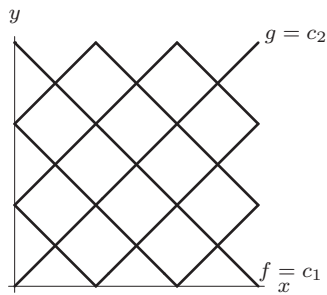

Figure 12.122

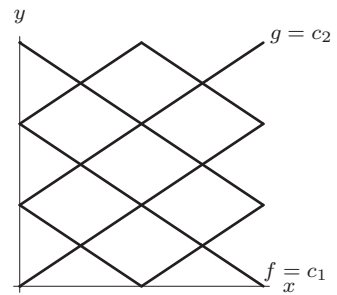

Figure 12.123

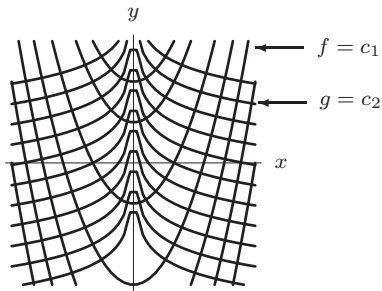

Figure 12.124

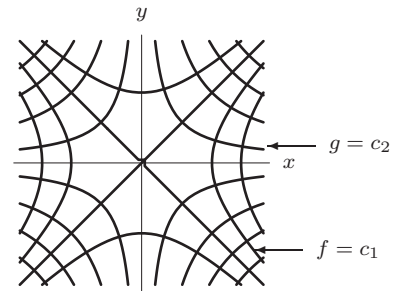

Figure 12.125

9. (a) is (I), because there is a minimum at the origin and the surface slopes steadily upward.
 (b) is (IV), because there is a maximum at the origin and the surface slopes increasingly steeply downward as we move away from the origin.
 (c) is (II), because there is a maximum at the origin and the surface slopes steadily downward.
 (d) is (III), because there is a minimum at the origin and the surface slopes increasingly fast upward as we move away from the origin.
10. Contours are lines of the form $3x - 5y + 1 = c$ as shown in Figure 12.126. Note that for the regions of x and y given, the c values range from $-12 < c < 12$ and are evenly spaced.

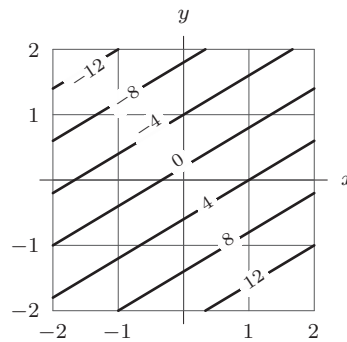

Figure 12.126

11. Since setting $z = c$, with $-1 \leq c \leq 1$ gives $y = \sin^{-1} c + 2n\pi$ or $y = \pi - \sin^{-1} c + 2n\pi = \text{constant}$, where n is any integer, contours are horizontal lines as shown in Figure 12.127.

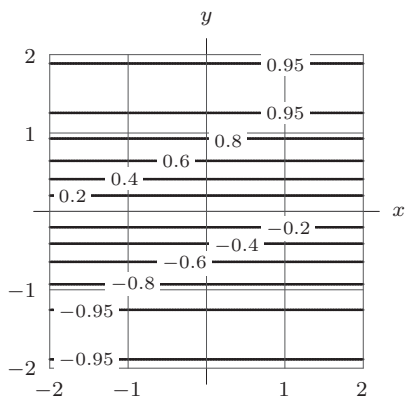

Figure 12.127

12. Contours are ellipses of the form $2x^2 + y^2 = c$ as shown in Figure 12.128. Note that for the ranges of x and y given, the range of c value is $1 \leq c < 9$ and are closer together farther from the origin.

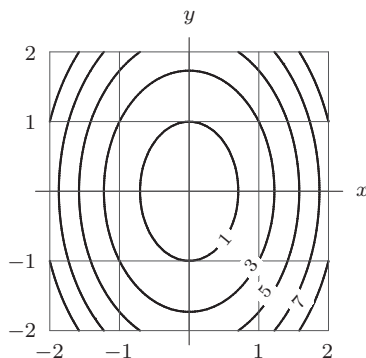

Figure 12.128

13. The contours are ellipses of the form $2x^2 + y^2 = -\ln c$ as shown in Figure 12.129. For the ranges of x and y given, the c values range from just above 0 to 1.

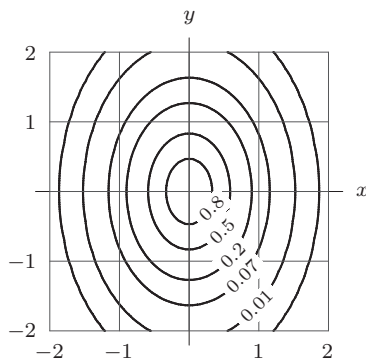

Figure 12.129

14. These conditions describe a line parallel to the z -axis which passes through the xy -plane at $(2, 1, 0)$.

15. The equation is $(x - 1)^2 + (y - 2)^2 + (z - 3)^2 = 25$

16. The equation will be of the form $mx + ny + ez = d$, but you can divide through by d to get an equation of the form $ax + by + cz = 1$ (d can not be zero, as the origin is not in the plane). Now plug in the points: From $(0, 0, 2)$, we get $a(0) + b(0) + c(2) = 1$. From this we get $c = \frac{1}{2}$. Similarly we get $a = \frac{1}{5}$, and $b = \frac{1}{3}$. So the equation that fits these points is

$$\frac{x}{5} + \frac{y}{3} + \frac{z}{2} = 1.$$

The equation of this plane can also be obtained by calculating the normal as the cross product of two vectors lying in the plane.

17. We complete the square

$$\begin{aligned} x^2 + 4x + y^2 - 6y + z^2 + 12z &= 0 \\ x^2 + 4x + 4 + y^2 - 6y + 9 + z^2 + 12z + 36 &= 4 + 9 + 36 \\ (x + 2)^2 + (y - 3)^2 + (z + 6)^2 &= 49 \end{aligned}$$

The center is $(-2, 3, -6)$ and the radius is 7.

18. A contour diagram is linear if the contours are parallel straight lines, equally spaced for equally spaced values of z . This contour diagram does not represent a linear function.
19. A contour diagram is linear if the contours are parallel straight lines, equally spaced for equally spaced values of z . This contour diagram could represent a linear function.
20. (a) Since the function is linear, the increment between successive entries in the same column is constant. From the third column we see that the increment is $2 - 8 = -6$. Subtract 6 to go from any entry in the table to the entry below it, and add 6 to get the entry above it. See Table 12.17.

Table 12.17

		y		
		2.5	3.0	3.50
x	-1	6	7	8
	1	0	1	2
	3	-6	-5	-4

- (b) From the third column of the table we calculate

$$\text{Slope in } x\text{-direction} = m = \frac{2 - 8}{1 - (-1)} = -3.$$

From the first row of the table we calculate

$$\text{Slope in } y\text{-direction} = n = \frac{8 - 6}{3.5 - 2.5} = 2.$$

The equation of the linear function is

$$\begin{aligned} f(x, y) &= z_0 + m(x - x_0) + n(y - y_0) \\ &= f(-1, 2.5) - 3(x - (-1)) + 2(y - 2.5) = -2 - 3x + 2y. \end{aligned}$$

21. The level surfaces appear to be circular cylinders centered on the z -axis. Since they don't change with z , there is no z in the formula, and we can use the formula for a circle in the xy -plane, $x^2 + y^2 = r^2$. Thus the level surfaces are of the form $f(x, y, z) = x^2 + y^2 = c$ for $c > 0$.
22. The paraboloid is $z = x^2 + y^2 + 5$, so it is represented by

$$z = f(x, y) = x^2 + y^2 + 5$$

and

$$g(x, y, z) = x^2 + y^2 + 5 - z = 0.$$

Other answers are possible.

23. Plane is $(x/2) + (y/3) + (z/4) = 1$, so it is represented by

$$z = f(x, y) = 4 - 2x - \frac{4}{3}y$$

and

$$g(x, y, z) = \frac{x}{2} + \frac{y}{3} + \frac{z}{4} = 1.$$

Other answers are possible.

24. The upper half of the sphere is represented by

$$z = f(x, y) = \sqrt{1 - x^2 - y^2}$$

and

$$g(x, y, z) = x^2 + y^2 + z^2 = 1.$$

Other answers are possible.

25. The sphere is $(x - 3)^2 + y^2 + z^2 = 4$, so the lower half is represented by

$$z = f(x, y) = -\sqrt{4 - (x - 3)^2 - y^2}$$

and

$$g(x, y, z) = (x - 3)^2 + y^2 + z^2 = 4.$$

Other answers are possible.

26. The level surfaces have equation $\cos(x + y + z) = c$. For each value of c between -1 and 1 , the level surface is an infinite family of planes parallel to $x + y + z = \arccos(c)$. For example, the level surface $\cos(x + y + z) = 0$ is the family of planes

$$x + y + z = \frac{\pi}{2} \pm 2n\pi, \quad n = 0, 1, 2, \dots$$

27. A cylindrical surface.

28. A cone.

29. (a) The contours of g are parallel straight lines, and equally spaced function values correspond to equally spaced contours. These are the characteristics of the contour diagram of a linear function.

- (b) The zero contour goes through the origin, so $g(0, 0) = 0$ is one value of the function.

The slope m in the x -direction, obtained from the function values at $(0, 0)$ and $(50, 0)$, is

$$m = \frac{g(50, 0) - g(0, 0)}{50 - 0} = \frac{10000 - 0}{50 - 0} = 200.$$

The slope n in the y -direction, obtained from the function values at $(0, 0)$ and $(0, 50)$, is

$$n = \frac{g(0, 50) - g(0, 0)}{50 - 0} = \frac{5000 - 0}{50 - 0} = 100.$$

We have the formula

$$\begin{aligned} g(x, y) &= z_0 + m(x - x_0) + n(y - y_0) \\ &= g(0, 0) + m(x - 0) + n(y - 0) = 200x + 100y. \end{aligned}$$

Problems

30. The cross-sections perpendicular to the t -axis are sine curves of the form $g(x, b) = (\cos b) \sin 2x$; these have period π . The cross-sections perpendicular to the x -axis are cosine curves of the form $g(a, t) = (\sin 2a) \cos t$; these have period 2π .

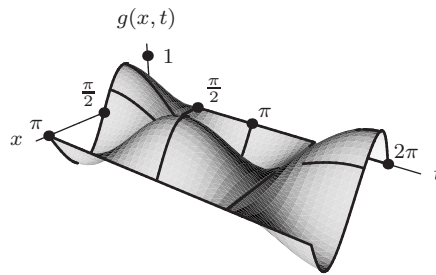

Figure 12.130: Graph $g(x, t) = \cos t \sin 2x$

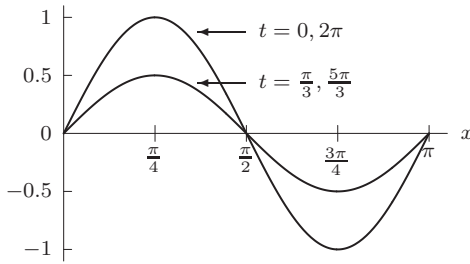

Figure 12.131: Cross-section $g(x, b) = (\cos b) \sin 2x$, with $b = 0, \pi/3, 5\pi/3, 2\pi$

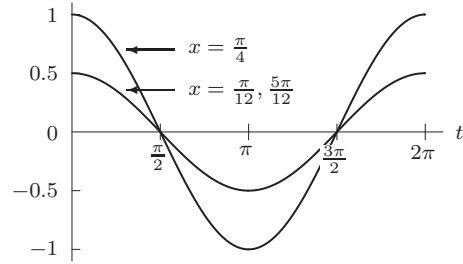

Figure 12.132: Cross-section $g(a, t) = (\sin 2a) \cos t$ with $a = \pi/12, \pi/4, 5\pi/12$

31. If

$$P_0 = f(L_0, K_0) = 1.01L_0^{0.75} K_0^{0.25}$$

then replacing L_0 and K_0 by $2L_0$ and $2K_0$ gives

$$\begin{aligned} f(2L_0, 2K_0) &= 1.01(2L_0)^{0.75} (2K_0)^{0.25} \\ &= 2^{0.75} 2^{0.25} \cdot 1.01L_0^{0.75} K_0^{0.25} \\ &= 2f(L_0, K_0) \\ &= 2P_0. \end{aligned}$$

So, doubling labor and capital doubles production.

32. (a) The level curve $f = 1$ is given by

$$\begin{aligned} \sqrt{x^2 + y^2} + x &= 1 \\ \sqrt{x^2 + y^2} &= 1 - x. \end{aligned}$$

Since $\sqrt{x^2 + y^2} \geq 0$, we must have $x \leq 1$. Squaring gives

$$x^2 + y^2 = (1 - x)^2 = 1 - 2x + x^2$$

So the level curve is given by

$$x = -\frac{1}{2}y^2 + \frac{1}{2}$$

with $x \leq 1$. Looking at the equation for the level curve, x always satisfies $x \leq 1$ since $x \leq \frac{1}{2}$. This means the level curve $f = 1$ is the parabola $x = -\frac{1}{2}y^2 + \frac{1}{2}$. See Figure 12.133.

Similarly, the level curve $f = 2$ has equation, valid for $x \leq 2$,

$$\begin{aligned} \sqrt{x^2 + y^2} &= 2 - x \\ x^2 + y^2 &= 4 - 4x + x^2 \\ x &= -\frac{1}{4}y^2 + 1 \end{aligned}$$

The level curve $f = 3$ has equation, valid for $x \leq 3$,

$$\begin{aligned} \sqrt{x^2 + y^2} &= 3 - x \\ x^2 + y^2 &= 9 - 6x + x^2 \\ x &= -\frac{1}{6}y^2 + \frac{3}{2}. \end{aligned}$$

Both $f = 2$ and $f = 3$ are valid for all x and y satisfying the respective equations, so the level curves are parabolas. See Figure 12.133.

(b) The level curve $f = c$ has equation, valid for $x \leq c$,

$$\begin{aligned} \sqrt{x^2 + y^2} &= c - x \\ x^2 + y^2 &= c^2 - 2cx + x^2 \\ x &= -\frac{1}{2c}y^2 + \frac{c}{2}. \end{aligned}$$

If $c > 0$, then any x satisfying this equation satisfies $x \leq \frac{c}{2}$, so we have $x < c$. Thus, the level curve exists for $c > 0$. If $c < 0$, then any x satisfying the level curve equation also satisfies $x \geq \frac{c}{2}$, so $x > c$ (since c is negative). Thus, the level curves do not exist for $c < 0$. If $c = 0$, we get the level curve $y = 0$ with $x \leq 0$. Summarizing, we have that level curves exist only for $c \geq 0$.

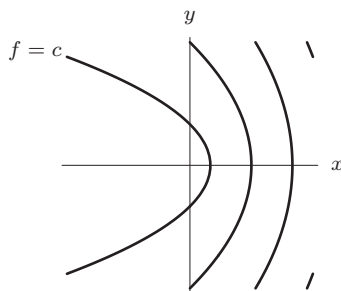

Figure 12.133

33. (a) You can see the sequence of values 1, 2, 3, 4, 5, 6, ... as you follow diagonal paths in the table upward to the right, changing to the next lower diagonal after reaching the top $x = 1$ row. The pattern continues in the same way, giving Table 12.18

Table 12.18

		y					
		1	2	3	4	5	6
x	1	1	3	6	10	15	21
	2	2	5	9	14	20	27
	3	4	8	13	19	26	34
	4	7	12	18	25	33	42
	5	11	17	24	32	41	51
	6	16	23	31	40	50	61

(b) It appears that the value of f increases by 1 whenever x is decreased by 1 and y is increased by 1. To check this, compute

$$\begin{aligned} f(x - 1, y + 1) &= (1/2)((x - 1) + (y + 1) - 2)((x - 1) + (y + 1) - 1) + (y + 1) \\ &= (1/2)(x + y - 2)(x + y - 1) + y + 1 \\ &= f(x, y) + 1 \end{aligned}$$

It appears that the value of f increases by 1 when moving from a point $(1, y)$ to the point $(y + 1, 1)$. To check this, compute

$$\begin{aligned} f(y + 1, 1) &= (1/2)((y + 1) + 1 - 2)((y + 1) + 1 - 1) + 1 \\ &= \frac{1}{2}y^2 + \frac{1}{2}y + 1 \\ &= (1/2)(1 + y - 2)(1 + y - 1) + y + 1 \\ &= f(1, y) + 1 \end{aligned}$$

34. Let us suppose that (x, y) approaches $(0, 0)$ along the line $y = x$. Then

$$f(x, y) = f(x, x) = \frac{x^3}{x^4 + x^2} = \frac{x}{x^2 + 1}.$$

Therefore

$$\lim_{\substack{(x,y) \rightarrow (0,0) \\ y=x}} f(x, y) = \lim_{x \rightarrow 0} \frac{x}{x^2 + 1} = 0.$$

On the other hand, if (x, y) approaches $(0, 0)$ along the parabola $y = x^2$ we have

$$f(x, y) = f(x, x^2) = \frac{x^4}{2x^4} = \frac{1}{2}$$

and

$$\lim_{\substack{(x,y) \rightarrow (0,0) \\ y=x^2}} f(x, y) = \lim_{x \rightarrow 0} f(x, x^2) = \frac{1}{2}.$$

Thus no matter how close they are to the origin, there will be points (x, y) such that $f(x, y)$ is close to 0 and points (x, y) such that $f(x, y)$ is close to $\frac{1}{2}$. So the limit

$$\lim_{(x,y) \rightarrow (0,0)} f(x, y)$$

does not exist.

35. Points along the positive x -axis are of the form $(x, 0)$; at these points the function looks like $x/2x = 1/2$ everywhere (except at the origin, where it is undefined). On the other hand, along the y -axis, the function looks like $y^2/y = y$, which approaches 0 as we get closer to the origin. Since approaching the origin along two different paths yields numbers that are not the same, the limit does not exist.

36. We will study the continuity of f at $(a, 0)$. Now $f(a, 0) = 1 - a$. In addition:

$$\begin{aligned} \lim_{\substack{(x,y) \rightarrow (a,0) \\ y > 0}} f(x, y) &= \lim_{x \rightarrow a} (1 - x) = 1 - a \\ \lim_{\substack{(x,y) \rightarrow (a,0) \\ y < 0}} f(x, y) &= \lim_{x \rightarrow a} -2 = -2. \end{aligned}$$

If $a = 3$, then

$$\lim_{\substack{(x,y) \rightarrow (3,0) \\ y > 0}} f(x, y) = 1 - 3 = -2 = \lim_{\substack{(x,y) \rightarrow (3,0) \\ y < 0}} f(x, y)$$

and so $\lim_{(x,y) \rightarrow (3,0)} f(x, y) = -2 = f(3, 0)$. Therefore f is continuous at $(3, 0)$.

On the other hand, if $a \neq 3$, then

$$\lim_{\substack{(x,y) \rightarrow (a,0) \\ y > 0}} f(x, y) = 1 - a \neq -2 = \lim_{\substack{(x,y) \rightarrow (a,0) \\ y < 0}} f(x, y)$$

so $\lim_{(x,y) \rightarrow (a,0)} f(x, y)$ does not exist. Thus f is not continuous at $(a, 0)$ if $a \neq 3$.

Thus, f is not continuous along the line $y = 0$. (In fact the only point on this line where f is continuous is the point $(3, 0)$.)

37. (a) A student with SATs of 1050 and a GPA of 3.0 has a z -value given by

$$z = 0.003 \cdot 1050 + 0.8 \cdot 3.0 - 4 = 1.55$$

Since $1.55 < 2.3$, this student will not be admitted.

- (b) A student with SATs of 1600 and GPA of y has a z -value given by

$$z = 0.003 \cdot 1600 + 0.8y - 4 = 0.8 + 0.8y = 0.8(y + 1)$$

Since $0.8(y + 1)$ may be greater than or less than 2.3, not all of the students with SAT scores of 1600 will be admitted.

- (c) A student with GPA of 4.3 and SATs of x has a z -value given by

$$z = 0.003x + 0.8 \cdot 4.3 - 4 = 0.003x - 0.56$$

Since $0.003x - 0.56$ may be greater than or less than 2.3, not all of the students with a high school GPA of 4.3 will be admitted.

- (d) See Figure 12.134.

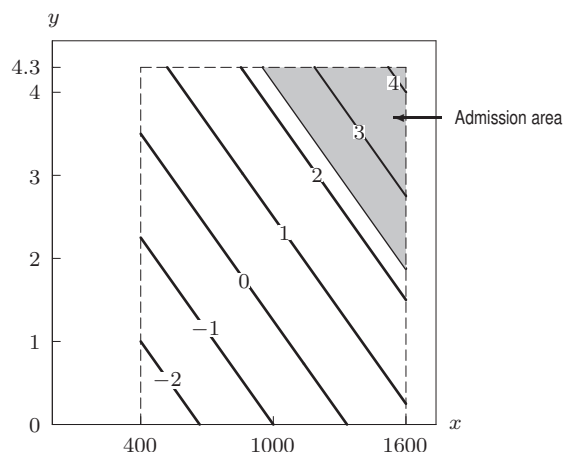

Figure 12.134

- (e) If $\Delta x = 100$, then $\Delta z = 0.003\Delta x = 0.003 \cdot 100 = 0.3$.
 If $\Delta y = 0.5$, then $\Delta z = 0.8 \cdot 0.5 = 0.4$.
 An extra 0.5 of high school GPA increases a student's z -value by more than an extra 100 points on the SAT. Thus, the increase in GPA is more important.
38. (a) The plane $y = 1$ intersects the graph in the parabola $z = (x^2 + 1) \sin(1) + x = x^2 \sin(1) + x + \sin(1)$. Since $\sin(1)$ is a constant, $z = x^2 \sin(1) + x + \sin(1)$ is a quadratic function whose graph is a parabola.
 Any plane of the form $y = a$ will do as long as a is not a multiple of π .
- (b) The plane $y = \pi$ intersects the graph in the straight line $z = \pi^2 x$. (Since $\sin \pi = 0$, the equation becomes linear, $z = \pi^2 x$ if $y = \pi$.)
- (c) The plane $x = 0$ intersects the graph in the curve $z = \sin y$.
39. (a) To find the level curves, we let T be a constant.

$$T = 100 - x^2 - y^2$$

$$x^2 + y^2 = 100 - T,$$

which is an equation for a circle of radius $\sqrt{100 - T}$ centered at the origin. At $T = 100^\circ$, we have a circle of radius 0 (a point). At $T = 75^\circ$, we have a circle of radius 5. At $T = 50^\circ$, we have a circle of radius $5\sqrt{2}$. At $T = 25^\circ$, we have a circle of radius $5\sqrt{3}$. At $T = 0^\circ$, we have a circle of radius 10.

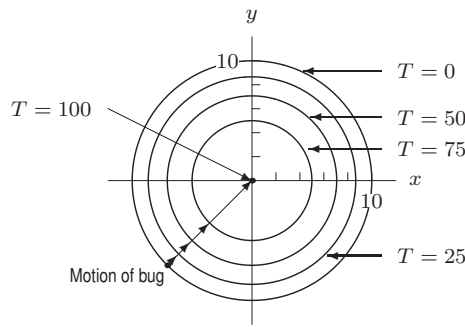

Figure 12.135

(b) No matter where we put the bug, it should go straight toward the origin—the hottest point on the xy -plane. Its direction of motion is perpendicular to the tangent lines of the level curves, as can be seen in Figure 12.135.

40. Let the equation of the plane be $z = ax + by + c$. When $z = 0$, the line on the xy -plane is $ax + by + c = 0$. Since we know that the plane intersects the xy -plane along the line $y = 2x + 2$ we have $b \neq 0$ and

$$-\frac{a}{b} = 2 \quad -\frac{c}{b} = 2$$

Since $(1, 2, 2)$ lies on the plane, we can use the equation $z = ax + by + c$ to get

$$2 = a + 2b + c$$

Solving the equations gives

$$\begin{aligned} a &= 2, \\ b &= -1, \\ c &= 2. \end{aligned}$$

Hence $z = 2x - y + 2$ and the linear function is $f(x, y) = 2x - y + 2$.

41. (a) Since $z = c$, where $-1 \leq c \leq 1$ is a constant, gives $\sqrt{x^2 + y^2} = \pm \cos^{-1}(c) + 2k\pi$, where k is any integer such that $\pm \cos^{-1}(c) + 2k\pi$ is non-negative, or $x^2 + y^2 = r^2$, where $r = \pm \cos^{-1}(c) + 2k\pi$, which represents a family of circles of radius r centered at $(0, 0)$, the level curves of the function are families of circles, as shown in Figure 12.136.

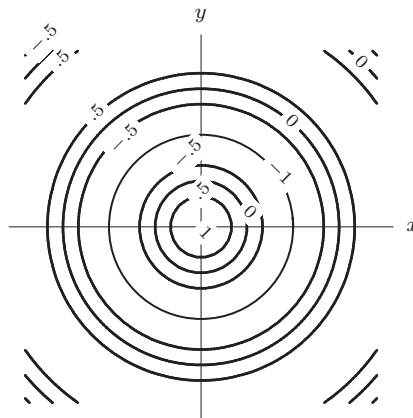

Figure 12.136

- (b) The plane containing the x - and z -axes is the plane $y = 0$. Thus the cross-section is $z = \cos \sqrt{x^2 + 0^2} = \cos(|x|) = \cos x$, as shown in Figure 12.137.

- (c) Denote the line $y = x$ in the xy -plane as r -axis and put units on it such that the units on the r -axis coincide with the units on the x -axis and y -axis, namely, $r^2 = x^2 + y^2$. Thus, the cross-section is $z = \cos \sqrt{r^2} = \cos(|r|) = \cos r$, as shown in Figure 12.138.

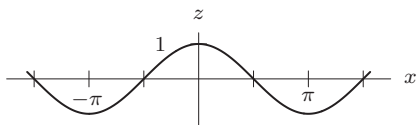

Figure 12.137

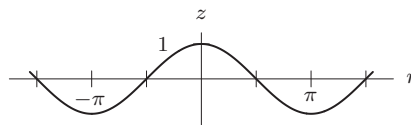

Figure 12.138

42. The function $y = f(x, 0) = \cos 0 \sin x = \sin x$ gives the displacement of each point of the string when time is held fixed at $t = 0$. The function $f(x, 1) = \cos 1 \sin x = 0.54 \sin x$ gives the displacement of each point of the string at time $t = 1$. Graphing $f(x, 0)$ and $f(x, 1)$ gives in each case an arch of the sine curve, the first with amplitude 1 and the second with amplitude 0.54. For each different fixed value of t , we get a different snapshot of the string, each one a sine curve with amplitude given by the value of $\cos t$. The result looks like the sequence of snapshots shown in Figure 12.139.

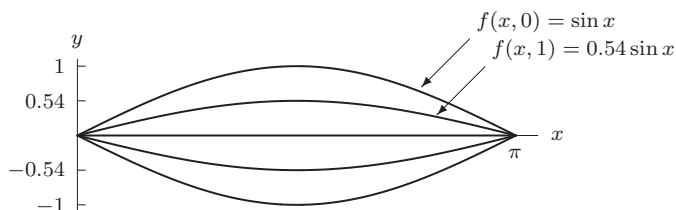

Figure 12.139

43. The function $f(0, t) = \cos t \sin 0 = 0$ gives the displacement of the left end of the string as time varies. Since that point remains stationary, the displacement is zero. The function $f(1, t) = \cos t \sin 1 = 0.84 \cos t$ gives the displacement of the point at $x = 1$ as time varies. Since $\cos t$ oscillates back and forth between 1 and -1 , this point moves back and forth with maximum displacement of 0.84 in either direction. Notice the maximum displacements are greatest at $x = \pi/2$ where $\sin x = 1$.
44. (a) For $t = 0$, we have $y = f(x, 0) = \sin x$, $0 \leq x \leq \pi$, as in Figure 12.140.

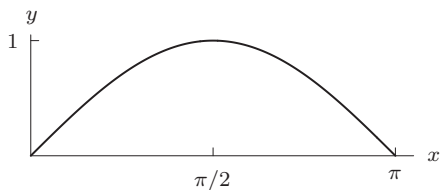

Figure 12.140

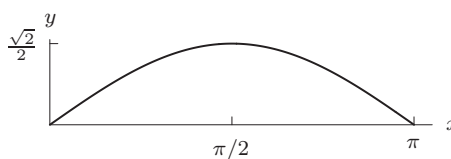

Figure 12.141

For $t = \pi/4$, we have $y = f(x, \pi/4) = \frac{\sqrt{2}}{2} \sin x$, $0 \leq x \leq \pi$, as in Figure 12.141.
 For $t = \pi/2$, we have $y = f(x, \pi/2) = 0$, as in Figure 12.142.



Figure 12.142

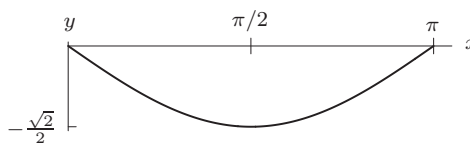

Figure 12.143

For $t = 3\pi/4$, we have $y = f(x, 3\pi/4) = \frac{-\sqrt{2}}{2} \sin x$, $0 \leq x \leq \pi$, as in Figure 12.143.
 For $t = \pi$, we have $y = f(x, \pi) = -\sin x$, $0 \leq x \leq \pi$, as in Figure 12.144.

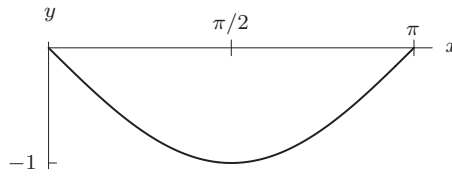

Figure 12.144

- (b) The graphs show an arch of a sine wave which is above the x -axis, concave down at $t = 0$, is straight along the x -axis at $t = \pi/2$, and below the x -axis, concave up at $t = \pi$, like a guitar string vibrating up and down.
45. (a) For $g(x, t) = \cos 2t \sin x$, our snapshots for fixed values of t are still one arch of the sine curve. The amplitudes, which are governed by the $\cos 2t$ factor, now change twice as fast as before. That is, the string is vibrating twice as fast.
- (b) For $y = h(x, t) = \cos t \sin 2x$, the vibration of the string is more complicated. If we hold t fixed at any value, the snapshot now shows one full period, i.e. one crest and one trough, of the sine curve. The magnitude of the sine curve is time dependent, given by $\cos t$. Now the center of the string, $x = \pi/2$, remains stationary just like the end points. This is a vibrating string with the center held fixed, as shown in Figure 12.145.

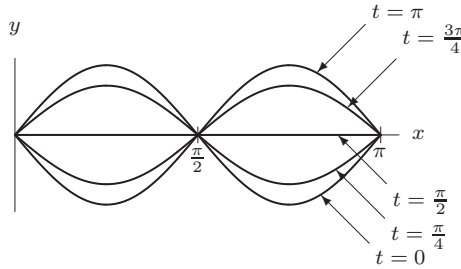

Figure 12.145: Another vibrating string: $y = h(x, t) = \cos t \sin 2x$

CAS Challenge Problems

46. (a) Let $C = (x, y, 0)$. Since distance $AC = 2$ we have $x^2 + y^2 = 2^2$, and since distance $BC = 2$ we have $(x - 2)^2 + y^2 = 2^2$. Solving these two equations, we have $C = (1, \sqrt{3}, 0)$ or $C = (1, -\sqrt{3}, 0)$. We will pick the first choice (the second choice gives different answers in the next part).
- (b) Let $D = (x, y, z)$. Distance $DA = 2$ implies that $x^2 + y^2 + z^2 = 4$. Distance $DB = 2$ implies that $(x - 2)^2 + y^2 + z^2 = 4$. Distance $DC = 2$ implies that $(x - 1)^2 + (y - \sqrt{3})^2 + z^2 = 4$. Solving these three equations, we have: $x = 1, y = 1/\sqrt{3}, z = 2\sqrt{2}/\sqrt{3}$ or $x = 1, y = 1/\sqrt{3}, z = -2\sqrt{2}/\sqrt{3}$. Picking the first choice we have $D = (1, 1/\sqrt{3}, 2\sqrt{2}/\sqrt{3})$.
- (c) The figure is a tetrahedron, that is, a polyhedron with four faces, each of which is an equilateral triangle: ABC, ABD, ACD, BCD .
47. (a)

$$f(x, f(x, y)) = 3 + x + 2(3 + x + 2y) = (3 + 2 \cdot 3) + (1 + 2)x + 2^2 y = 9 + 3x + 4y$$

$$f(x, f(x, f(x, y))) = 3 + x + 2(3 + x + 2(3 + x + 2y))$$

$$= (3 + 2 \cdot 3 + 2^2 \cdot 3) + (1 + 2 + 2^2)x + 2^3 y = 21 + 7x + 8y$$

- (b) From part (a) we guess that the general pattern for k nested f s is

$$(3 + 2 \cdot 3 + 2^2 \cdot 3 + \dots + 2^{k-1} \cdot 3) + (1 + 2 + 2^2 + \dots + 2^{k-1})x + 2^k y$$

Thus

$$f(x, f(x, f(x, f(x, f(x, f(x, y)))))) =$$

$$(3 + 2 \cdot 3 + 2^2 \cdot 3 + \dots + 2^5 \cdot 3) + (1 + 2 + 2^2 + \dots + 2^5)x + 2^6 y = 189 + 63x + 64y.$$

48. (a) Since $f(1, 1, 1) = 16$, $f(1, 1, 2) = 21$, an increase of 1 in z increases the value of f by 5. Thus we estimate $f(1, 1, 3) \approx 21 + 5 = 26$. Similarly, since $f(1, 0, 1) = 20$, $f(1, 1, 1) = 16$, an increase of 1 in y decreases the value of f by 4. So we estimate $f(1, 2, 1) \approx 16 - 4 = 12$.
- (b) When x and y are fixed at 1, f is a linear function of z , thus the linear approximation will give a precise answer for $f(1, 1, 3)$. However, when x and z are fixed at 1, f is the sum of an exponential function of y and a linear function, thus the linear approximation will not be accurate for $f(1, 2, 1)$.
- (c) Since $f(x, y, z) = ax^2 + byz + czx^3 + d2^{x-y}$ and $f(1, 0, 1) = 20$, $f(1, 1, 1) = 16$, $f(1, 1, 2) = 21$, $f(0, 0, 1) = 6$, we have

$$\begin{aligned} a + c + 2d &= 20 \\ a + b + c + d &= 16 \\ a + 2b + 2c + d &= 21 \\ d &= 6 \end{aligned}$$

Solving for a, b, c, d , we get $f(x, y, z) = 5x^2 + 2yz + 3zx^3 + 6 \cdot 2^{x-y}$.

- (d) $f(1, 1, 3) = 26$, which matches the estimate in part (a). $f(1, 2, 1) = 15$, which does not agree with the estimate in part (a).

PROJECTS FOR CHAPTER TWELVE

1. (a) The Leq is greatest near the runways. The largest contour marked is 72 dB; Heathrow's two main runways are located within this contour and run east-west. The noise level on the runways exceeds 72 dB. For comparison, the noise level 50 feet from the edge of a freeway in mid-morning is about 76 dB.
- (b) Since the prevailing wind is from the west, the planes take off towards the west and land coming in from the east, which explains why the contours are aligned east-west. Many of the planes taking off want eventually to go east, so they turn off to the southwest to start a U-turn back to the east. A limited number, particularly those heading for transatlantic flights, turn right; fewer still head due west on a straight-out departure. When planes are approaching or departing, they have to use considerable power at low altitude, and hence are significantly noisier; this noise is concentrated at the end of the runways.
- (c) The noise level falls off rapidly to the north and south of the runways. This is reflected in the fact that the contours are very close together along the length of both runways.
- (d) Suppose the decibel measure of the sound, B_1 , on one contour is given by

$$B_1 = 10 \log_{10} \left(\frac{L_1}{L_0} \right)$$

and the decibel measure of the sound on the next higher contour, B_2 , is

$$B_2 = 10 \log_{10} \left(\frac{L_2}{L_0} \right).$$

Since contours are labeled at 3 dB intervals,

$$3 = B_2 - B_1 = 10 \left(\log_{10} \left(\frac{L_2}{L_0} \right) - \log_{10} \left(\frac{L_1}{L_0} \right) \right) = 10 \log_{10} \left(\frac{L_2/L_0}{L_1/L_0} \right) = 10 \log_{10} \left(\frac{L_2}{L_1} \right).$$

Solving for L_2/L_1 gives

$$\frac{L_2}{L_1} = 10^{3/10} \approx 2.$$

Thus, moving from one contour to the next at 3 dB higher corresponds to approximately doubling the sound intensity.

- (e) We have shown that an increase of 3 dB corresponds approximately to doubling the sound intensity, so a decrease of 3 dB corresponds approximately to halving the sound intensity. We are told that the new jets will make 50% less noise, so sound intensity will be halved. Thus, we will subtract 3 dB from each contour value; for example, the present 57 dB contour will be labeled as 54 dB.

2. (a) About 15 feet along the wall, because that's where there are regions of cold air (55°F and 65°F).
 (b) Roughly between 10 am and 12 noon, and between 4 pm and 6 pm.
 (c) Roughly between midnight and 2 am, between 10 am and 1 pm, and between 4 pm and 9 pm, since that is when the temperature near the heater is greater than 80°F .
 (d)

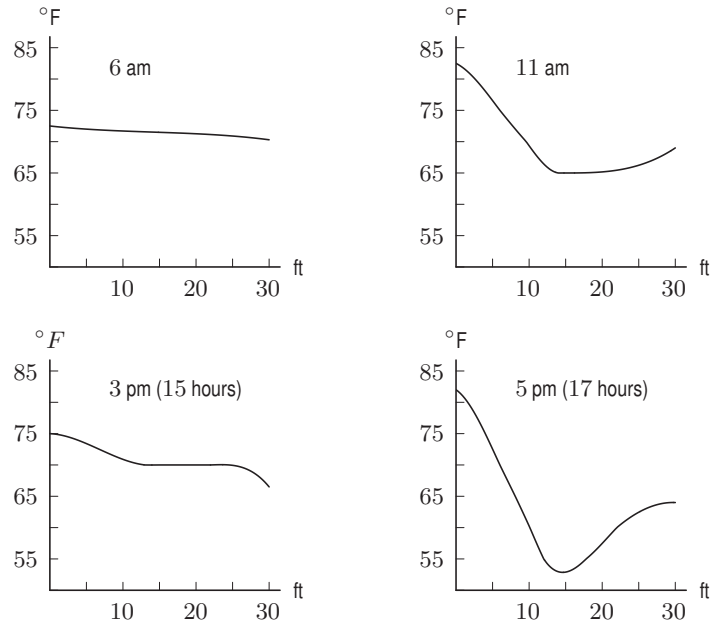

Figure 12.146

(e)

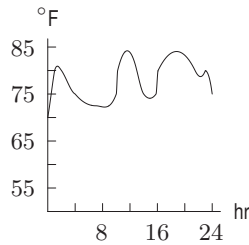

Figure 12.147: Temp. vs. Time at heater

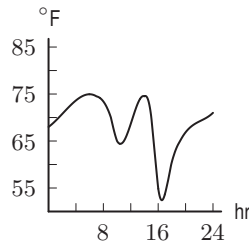

Figure 12.148: Temp. vs. Time at window

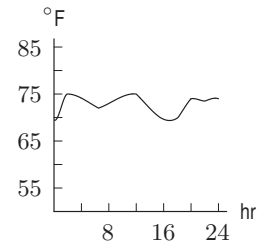

Figure 12.149: Temp. vs. Time midway between heater and window

- (f) The temperature at the window is colder at 5 pm than at 11 am because the outside temperature is colder at 5 pm than at 11 am.
 (g) The thermostat is set to roughly 70°F . We know this because the temperature in the room stays close to 70°F until we get close (a couple of feet) to the window.
 (h) We are told that the thermostat is about 2 feet from the window. Thus, the thermostat is either about 13 feet or about 17 feet from the wall. If the thermostat is set to 70°F , every time the temperature at the thermostat goes over or under 70°F , the heater turns off or on. Look at the point at which the vertical lines at 13 feet or about 17 feet cross the 70°F contours. We need to decide which of these crossings correspond best with the times that the heater turns on and off. (These times can be seen along the wall.) Notice that the 17 foot line does not cross the 70°F contour after 16 hours (4 pm). Thus, if the thermostat were 17 feet from the wall, the heater would not turn off after 4 pm. However, the heater does turn off at about 21 hours (9 pm). Since this is the time that the 13 foot line crosses the 70°F contour, we estimate that the thermostat is about 13 feet away from the wall.

3. (a) Let x = distance (microns) from center of waveguide, t = time (nanoseconds) as shown in the problem, and I = intensity of light as marked on the given level curves.

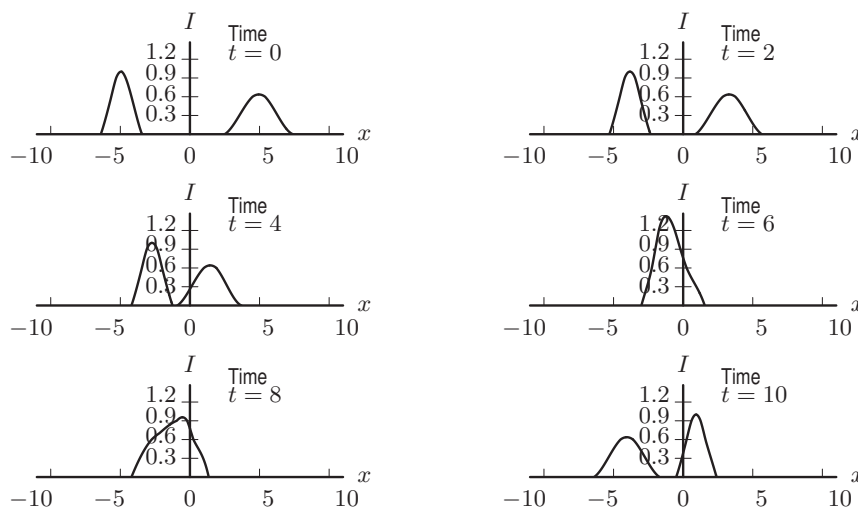

Figure 12.150

- (b) Two waves would start out at opposite ends of the screen. The wave on the left would be slightly taller and narrower than the wave on the right. The waves would move toward one another, the wave on the right moving a little faster. They would meet to the left of the center and appear to merge, becoming taller. They would then proceed in the directions they were initially going, ultimately leaving the screen on the side opposite to where they began.
- (c) Let x = distance (microns), t = time (nanoseconds), and I = intensity.

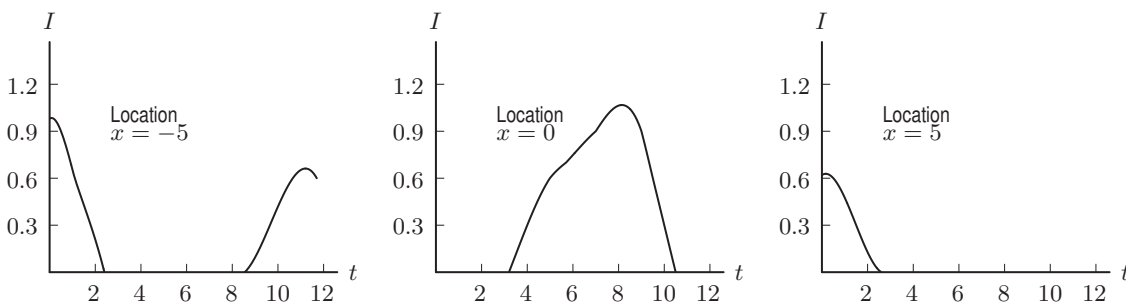

Figure 12.151

- (d) Two pulses of light are traveling down a wave-guide toward one another. They meet in the center and, as they pass through one another, appear brighter. They then continue along in the wave-guide in the directions they were going.